

# AB



---

## INSTRUCTIONS AND MAINTENANCE MANUAL

---



# INSTRUCTIONS AND MAINTENANCE MANUAL

## ASSEMBLY

### APPLICATION OF EUROPEAN DIRECTIVES

See document of European Directives applicable to **CMO Valves**.



Valve **AB** complies with the Directive on Equipment and Protective Systems for Potentially Explosive Atmospheres. In these cases the logo will appear on the identification label. This label shows the exact classification of the zone in which the valve can be used. The user is responsible for its use in any other zone.

### HANDLING

When handling the equipment please pay special attention to the following points:

- **SAFETY WARNING:** Before handling the valve check that the crane to be used is capable of bearing its weight.
- Do not lift the valve or hold it by the actuator. Lifting the valve by the actuator can lead to operating problems as it is not designed to withstand the valve's weight.
- Do not lift the valve or hold it by the actuator. Lifting the valve by the actuator can lead to operating problems as it is not designed to withstand the valve's weight.
- To prevent damage, especially to the anticorrosive protection, it is recommended to use soft straps to lift the knife gate valves. These straps must be fitted around the top of body.
- Packing in wooden boxes: If the equipment is packed in wooden boxes these must be provided with clearly marked holding areas where the slings will be placed when securing them. In the event that two or more valves are packed together, separation and securing elements must be provided between them to prevent possible movements, knocks and friction during transport. When storing two or more valves in the same box you must ensure they are correctly supported to prevent deformations. In the case of dispatches by sea we recommend the use of vacuum bags inside the boxes to protect the equipment from contact with sea water.
- Pay special attention to maintaining the correct levelling of the valves during loading and unloading as well as during transport to prevent deformations in the equipment. For this purpose we recommend the use of mounts or trestles.



### INSTALLATION

In order to avoid personal harm and other type of damage (to property, the plant, etc.) please follow these recommendations:

- The staff responsible for the handling and maintenance of the equipment must be qualified and trained in operations with this type of equipment.
- Use appropriate personal protection (gloves, safety boots, goggles, helmet, reflective vest...).
- Shut off all operating lines to the valve and put up a warning sign.
- Completely isolate the valve from the whole process.
- Depressurise the process.
- Drain all the line's fluid through the valve.
- Use hand tools not electric tools during the installation and maintenance, in according to current regulations.



## ADVANTAGE

### ASPECTS TO BE CONSIDERED DURING ASSEMBLY

Before installation, inspect the valve body and components for any possible damage occurred during transport or storage.

Make sure that the valve's inside cavities are clean. Inspect the pipes and the flanges to make sure they contain no foreign material and are clean.

As the AB valve is bidirectional, it does not need indications to mark the flow direction or the location of the sealing joint.

They can be installed in either of their two directions (Fig. 1)

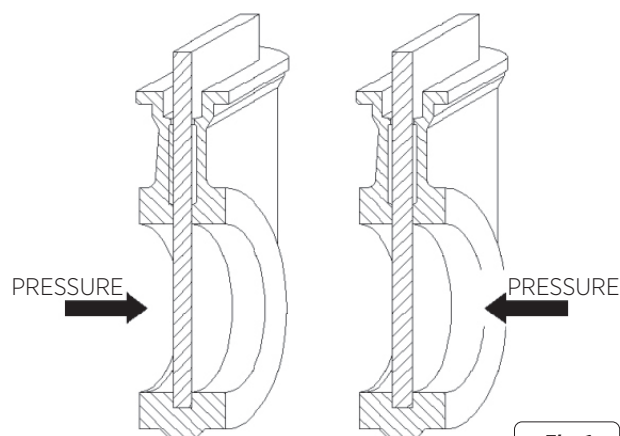

Fig. 1

The direction of the fluid and the pressure do not always coincide, but with bidirectional valves this has no influence when assembling the valve as its operation will be the same (Fig. 2).

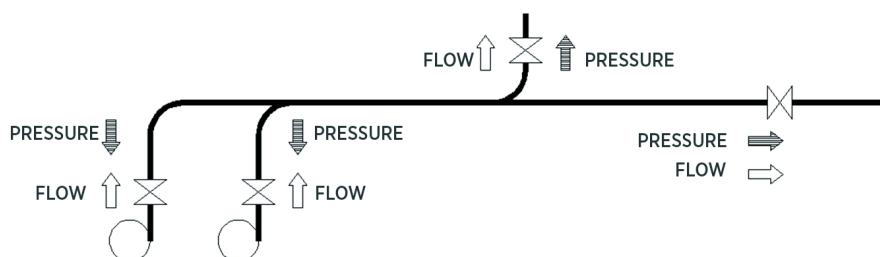

Fig. 2

Special care must be taken to maintain the correct distance (gap) between the flanges and ensure they are correctly aligned and parallel (Fig. 3).

The incorrect position or installation of the flanges can cause deformations on the valve's body which can cause difficulties during operation.

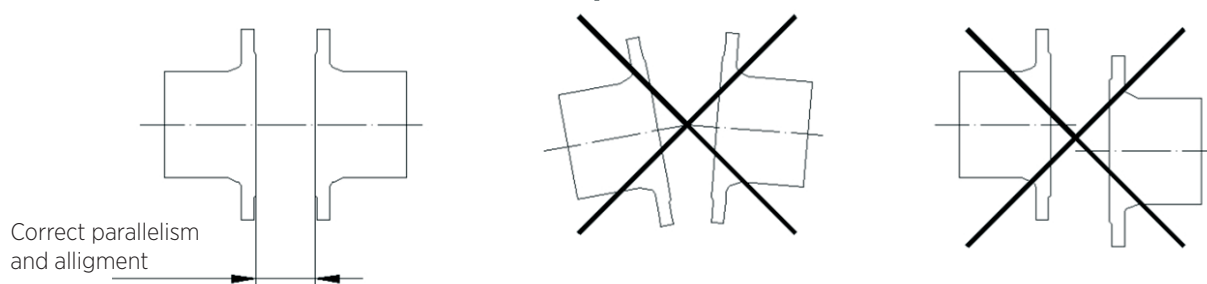

Fig. 3

It is very important to make sure that the valve is correctly aligned and parallel to the flanges to prevent leakages and avoid deformations. The screws in the tapped blind holes will have a maximum depth and will never reach the bottom of the hole.

## ASSEMBLY POSITIONS (Horizontal Pipe)

In horizontal pipes it is recommended that **CMO Valves** valves be assembled in vertical position, although other assembly positions are also possible.

**Position 1:** This is the most advisable position.

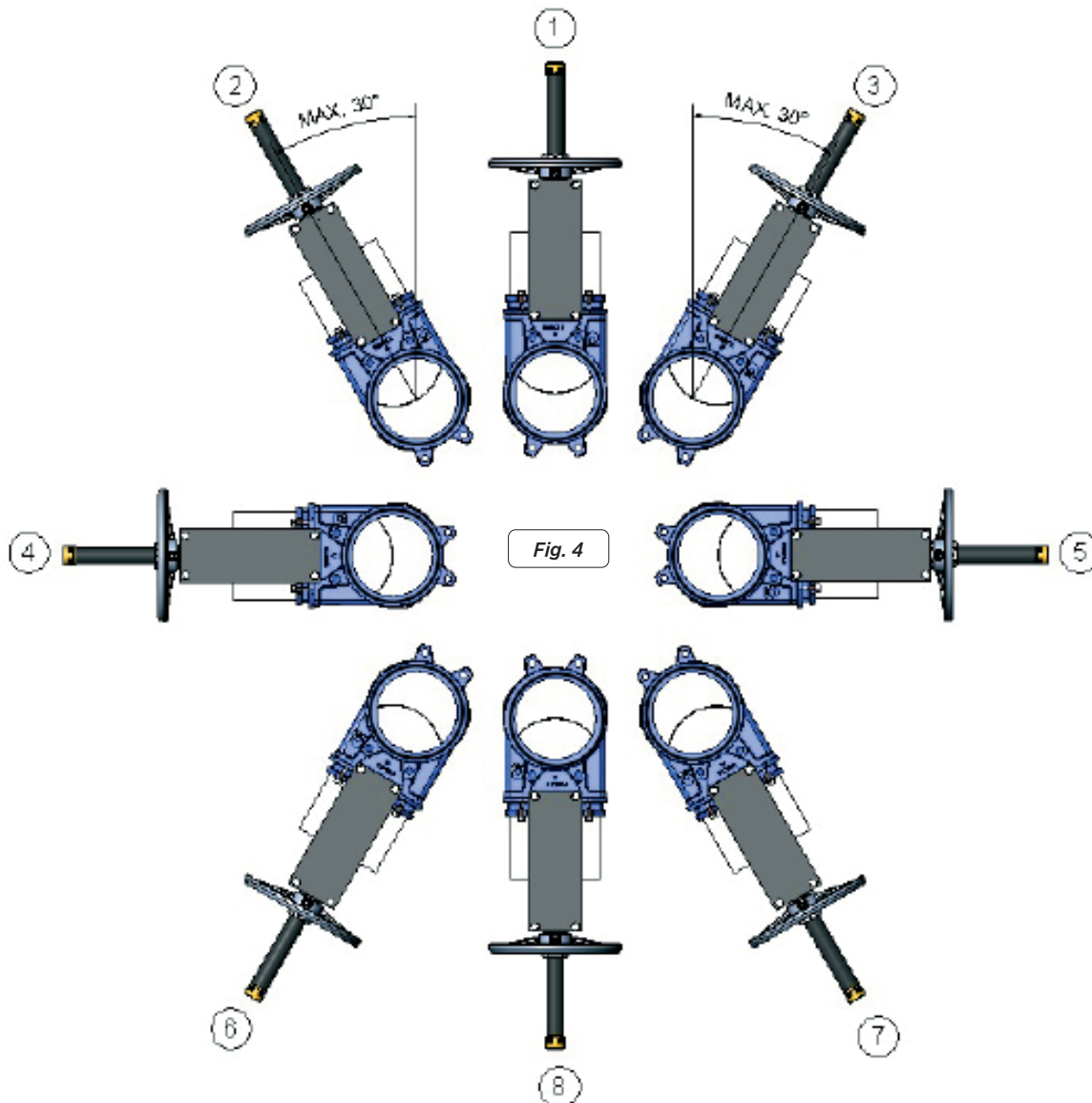

**Position 8:** The valve can be installed in this position but you are advised to contact **CMO Valves** if this is necessary.

**Positions 2, 3, 6 and 7:** For large valves (more than ND300), the maximum angle with the installation vertical is 30°. For smaller sizes the angle can be increased up to 90° (positions 4 and 5).

When it is necessary to install large valves in any of these positions, it is recommended to consult **CMO Valves**, as in these cases, due to the weight of the actuator, a suitable support must be made to prevent deformations and operating problems in the valves.

**Positions 4 and 5:** For smaller sized valves, the valves can be installed in these positions. To install larger valves (more than ND300) in any of these positions, please contact **CMO Valves**.

In these cases, due to the weight of the actuator, a suitable support must be made to prevent deformations and operating problems in the valves.

## ASSEMBLY POSITIONS (Vertical/Inclined Pipe)

**CMO Valves** valves can be assembled in all positions; however, certain aspects must be taken into account:

**Positions 1, 2 and 3:** In these positions, it is recommended to make a suitable support, because, due to the weight of the actuator, deformations may arise and this can lead to operating problems in the valves.

Once the valve has been installed, check that all the screws and nuts have been correctly tightened and that the whole valve action system has been correctly adjusted (electrical connections, pneumatic connections, instruments...).

All **CMO Valves** valves are tested at its facilities, however, during the handling and transport the screws on the packing gland can come loose and must be re-tightened.

Once the valve is installed in the pipeline and it has been pressurised, it is very important to check for any leakages from the packing gland to the atmosphere.

In the event of a leakage, tighten the nuts on the packing gland crosswise until the leakage stops, ensuring that there is no contact between the packing gland and the gate.

A very high tightening torque on the packing gland's nuts can lead to problems, such as an increase in the valve's torque, reduction in the packing's working life, or the breaking of the packing gland.

If electrical connections are present or you are in an ATEX zone, earth connections must be made before starting. In an ATEX zone, check the continuity between the valve and the pipeline (EN 12266-2, annex B, points B.2.2.2. and B.2.3.1.). Check the pipeline's earth connection and the conductivity between the outlet and inlet pipelines

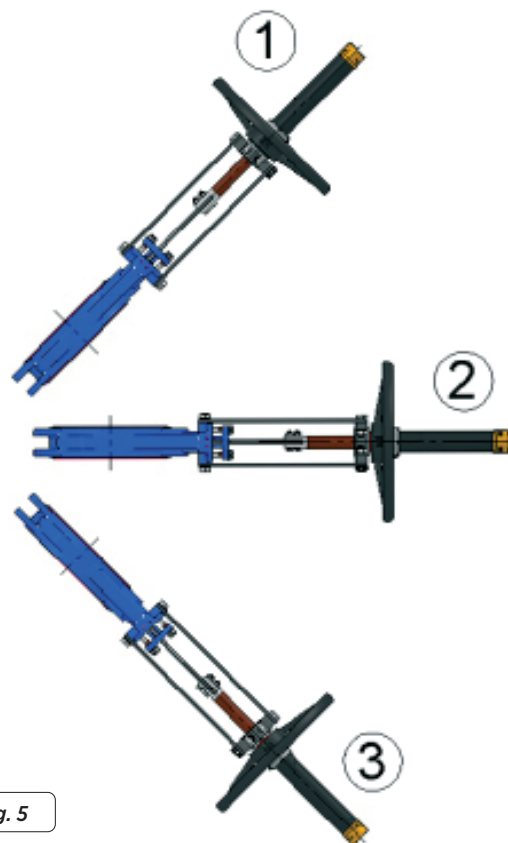

Fig. 5

## ACTUATOR

### HANDWHEEL (Rising or Non-Rising Stem and Stem with Gear Box)

To operate the valve: Turn the handwheel clockwise to close or anticlockwise to open.

### CHAINWHEEL

To operate the valve pull one of the chain's vertical drops, taking into account that locking is carried out when the chainwheel turns clockwise.

### LEVER

First loosen the position locking clamp located on the yoke. Once it is unlocked raise the lever to open or lower it to close. To complete the operation lock the lever again.

### PNEUMATIC (Double and Single Acting), HYDRAULIC (Double and Single Acting)

This actuator can be manually operated (via pushbuttons), and automatically operated via various sensors, detectors, timers...

### MOTORISED (Rising or Non-Rising Stem and Stem with Gear Box)

This actuator can also be operated manually or automatically, each different type of actuator will have its own instructions.

H/A = RISING STEM  
H/NA = NON-RISING STEM



LEVER H/A	HANDWHEEL NON-RISING STEM H/NA	HANDWHEEL RISING STEM H/A	CHAIN HANDWHEEL H/A H/NA	ELECTRIC-MOTOR ACTUSTOR H/A H/NA	HANDWHEEL GEAR-BOX H/A H/NA	HYDRAULIC ACTUATOR H/A	PNEUMATIC ACTUATOR H/A	SINGLE-ACTING PNEUMATIC ACTUATOR H/A
--------------	---	---------------------------------	-----------------------------------	---	--------------------------------------	------------------------------	------------------------------	---

Fig. 6

## MAINTENANCE

 In order to avoid personal harm and other types of damage (to the plant, etc.) please follow these recommendations:

- The staff member responsible for the installation, operation and maintenance of the valves must be qualified and trained in the operation of similar valves.
- Appropriate personal protection must be used (gloves, safety boots, goggles, helmet...).
- Shut off all operating lines to the valve and put up a warning sign.
- Completely isolate the valve from the process.
- Fully depressurise the process.
- Drain all the line's fluid through the valve.
- Use hand tools not electric tools during the installation and maintenance, in according to current regulations.

The only maintenance required in this type of valve is to change the seat's rubber joint (if soft seated valve is used) and the packing. It is recommended to check the seal every 6 months, however its working life will depend on the valve's operating conditions, such as: Pressure, temperature, number of operations, fluid composition, among others.

- The maintenance sta must consider the risks of explosion and ATEX training is recommended.
- If the fluid transported constitutes an internal explosive atmosphere, the user must regularly check the installation's correct watertight integrity.

- 
- Regular cleaning of the valve to prevent accumulation of dust.
  - Assemblies not permitted at the end of the line.
  - Avoid painting the products supplied.

### LUBRICATION

- 
- It is recommended to lubricate the stem twice a year by removing the protection cap and filling it with grease up to half its volume.
- After the maintenance and in an ATEX zone, you must check the electrical continuity between the pipe and the rest of the valve's components, such as the body, gate, stem, with EN 12266-2 Standard, annex B, points B.2.2.2. and B.2.3.1

## IMPORTANT SAFETY ASPECTS

- To work under suitable safety conditions, the magnetic and electrical elements must be at rest and the air tanks depressurized. Likewise, also the electrical control cabinets must be out of service. The maintenance personnel must be aware of the safety regulations and only work can be started under the order of the on-site safety personnel.
- The safety areas must be clearly marked and the support of auxiliary equipment (ladders, scaffolding, etc.) on levers or moving parts must be avoided so that the guillotine can move.
- In equipment with spring return drives, the guillotine must be mechanically locked and only unlocked when the drive is pressurized.
- In equipment with electric drive, it is recommended to disconnect it from the network in order to access the moving parts without any risk.
- Due to its great importance, it must be checked that the valve shaft is free of load before disassembling the drive system.

## REPLACING THE SEALING JOINT (Fig. 7)

1. Make sure there is absolutely no pressure and fluid in the installation.
2. Remove the valve from the pipeline.
3. Remove the actuator and safety guards by unscrewing and removing the bolts connecting the stem to the gate and the support plate to the body.
4. Remove the packing gland (4).
5. Remove the packing (5) taking care not to damage its O-ring.
6. Remove the gate (2)
7. Clean the inside surfaces of the valve.
8. Fit a new sealing joint (3) with the same dimensions as the old one.
9. Assemble the rest of the disassembled valve following the steps in the disassembly process in the reverse order.

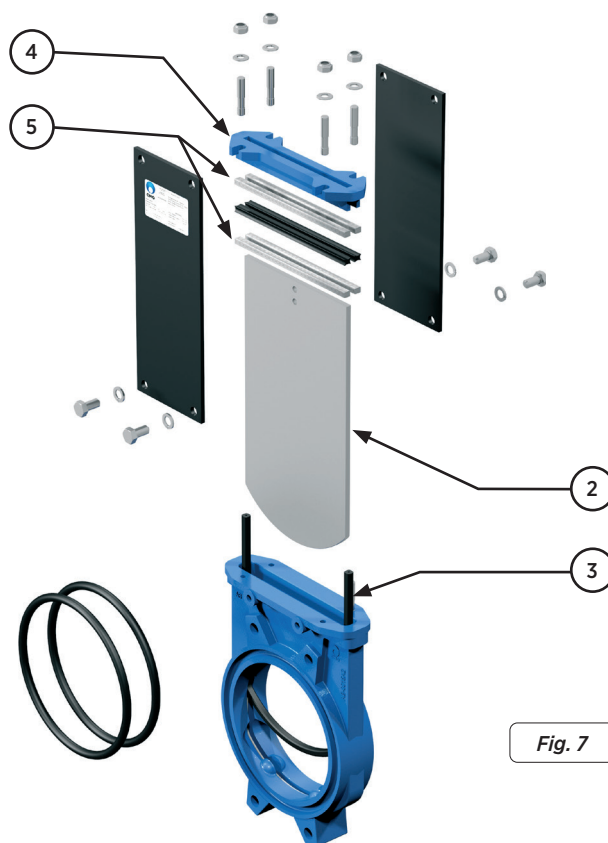

Fig. 7

**\*Note:** During the assembly of the new sealing joint it is recommended to apply “Vaseline” to the seal to facilitate the assembly process and the correct operation of the valve (do not use oil or grease); table 1 below shows details of the Vaseline used.

WHITE PETROLEUM JELLY		
Saybolt colour	ASTM D-156	15
Melting point (°C)	ASTM D-156	60
Viscosity at 100°C	ASTM D-156	5
Penetration 25°C mm/10	ASTM D-156	165
Silicone content	Not have	
Pharmacopeia BP	OK	

Table. 1

## REPLACING THE PACKING (Fig. 8)

1. Make sure there is absolutely no pressure and fluid in the installation.
2. Place the valve in open position.
3. Loosen the screws that connect the stem or rod to the gate.
4. Release the connection between the support plate and the body.
5. Release and remove the packing gland (4) and the safety guards where present.
6. Remove the damaged packing (5) using a pointed tool, taking care not to damage the surface of the gate (2).
7. Carefully clean the packing box and make sure there are no metal parts inside.
8. Insert the new packing (5). During this operation it is very important for both ends to be perfectly joined. Below we show the packing dimensions (Table 2).  
As standard, **CMO Valves** packing is composed of 3 lines (2 packing lines and 1 rubber joint line in the middle).
9. Place the packing gland in its original position, making sure it does not touch the gate, carefully tighten all the screws crosswise and make sure the same distance is left between the gate and the packing gland on both sides.
10. Assemble steps 3 and 4.
11. Perform several manoeuvres with no load, checking the correct operation of the valve and ensuring the packing gland is correctly centred.
12. Pressurise the valve in the line and tighten the packing gland crosswise, enough to prevent leakages to the atmosphere.

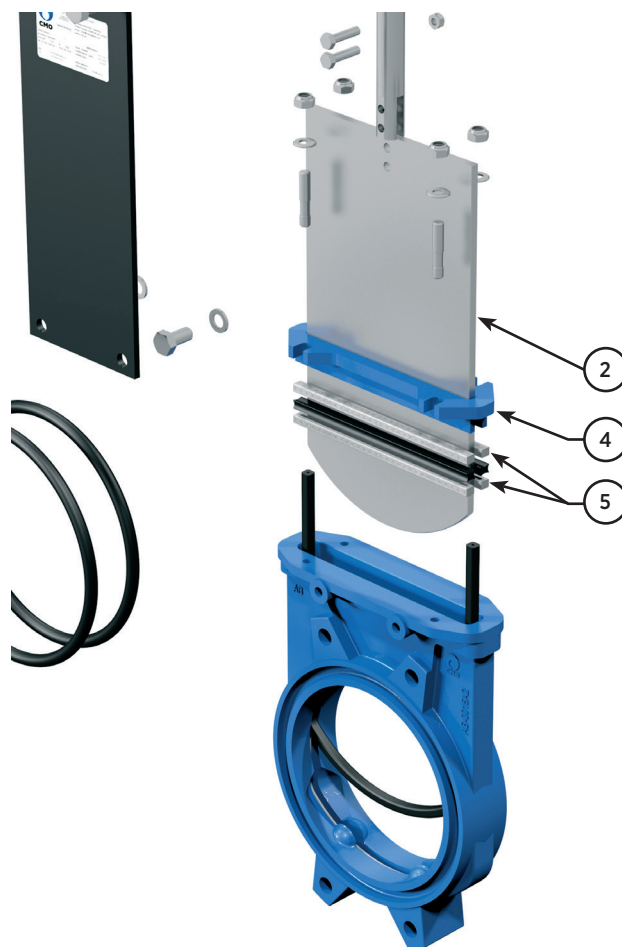

Fig. 8

DIAMETER	PACKING	RUBBER RING
DN50	4 lines de 8 x 8 x 66	2 lines de 8 x 8 x 66
DN65	4 lines de 8 x 8 x 81	2 lines de 8 x 8 x 81
DN80	4 lines de 8 x 8 x 96	2 lines de 8 x 8 x 96
DN100	4 lines de 8 x 8 x 116	2 lines de 8 x 8 x 116
DN125	4 lines de 8 x 8 x 141	2 lines de 8 x 8 x 141
DN150	4 lines de 8 x 8 x 166	2 lines de 8 x 8 x 166
DN200	4 lines de 8 x 8 x 224	2 lines de 8 x 8 x 224
DN250	4 lines de 10 x 10 x 272	2 lines de 10 x 10 x 272
DN300	4 lines de 10 x 10 x 326	2 lines de 10 x 10 x 326
DN350	4 lines de 10 x 10 x 376	2 lines de 10 x 10 x 376
DN400	4 lines de 10 x 10 x 431	2 lines de 10 x 10 x 431
DN450	4 lines de 10 x 10 x 481	2 lines de 10 x 10 x 481
DN500	4 lines de 14 x 14 x 531	2 lines de 14 x 14 x 531
DN600	4 lines de 14 x 14 x 637	2 lines de 14 x 14 x 637

Table. 2

**Note:** - If it is not possible to place a rubber joint in the middle another packing line should be used instead.  
- Dimensions are expressed in millimeters.



## MAINTENANCE OF THE PNEUMATIC ACTUATOR

The pneumatic cylinders in our valves are manufactured and assembled at our premises. The maintenance of these cylinders is simple, if your need to replace any elements and you have any questions please consult **CMO Valves**. Below is an exploded diagram of the pneumatic actuator (fig 9) and a list of the cylinder's components (table 3). The top cover and the support cover are usually made of aluminium, but from pneumatic cylinders greater than Ø200 mm, they are made of cast ductile iron.

The maintenance kit normally includes: The socket and its joints and the scraper, and if the customer wishes the piston is also supplied. Below we show the steps to follow to replace these parts.

1. Position the valve in closed position and shut off the pneumatic circuit pressure.
2. Loosen the cylinder air input connections.
3. Release and remove the cylinder cap (5), the cylinder tube (4) and the tie rods (16).
4. Loosen the nut (14) which connects the piston (3) and the rod (1), remove the parts. Disassemble the cir-clip (10) and remove socket (7) with its joints (8 & 9).
5. Release and remove the cylinder head (2), in order to remove the scraper (6).
6. Replace the damaged parts with new ones and assemble the actuator in the opposite order to that described for the disassembly.

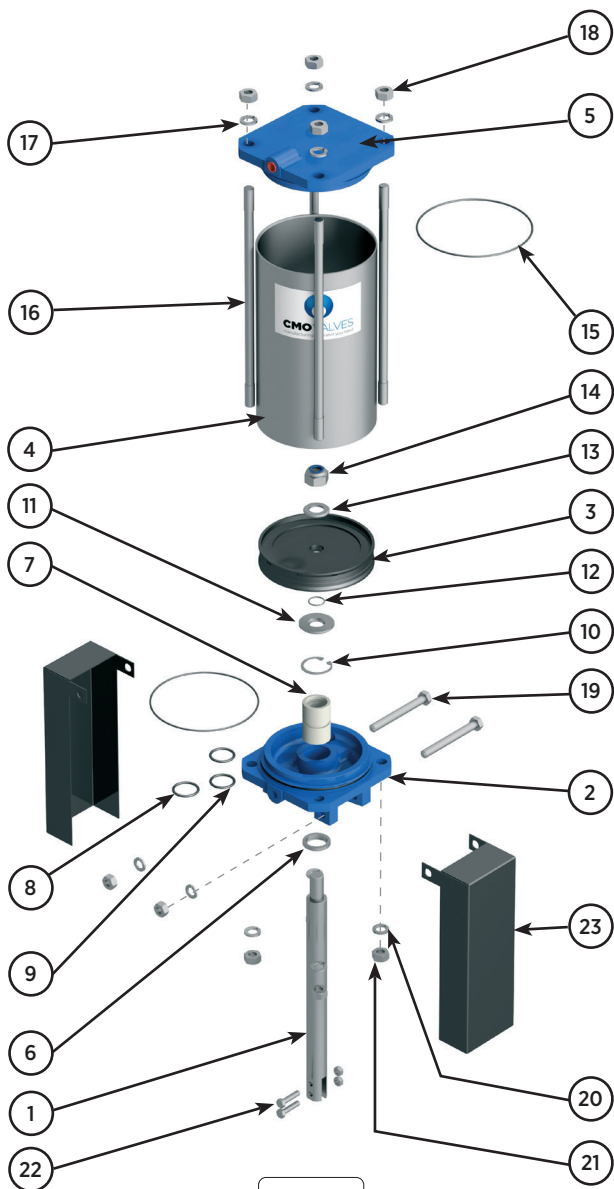

Fig. 9

PNEUMATIC ACTUATOR		
POS.	DESCRIPTION	MATERIAL
1	STEM	AISI-304
2	COVER SUPPORT	ALUMINIUM
3	PISTON	S275JR + EPDM
4	CASING	ALUMINIUM
5	UPPER COVER	ALUMINIUM
6	SCRAPER	NITRILE
7	SOCKET	AP6
8	EXTERIOR O-RING	NITRILE
9	INTERIOR O-RING	NITRILE
10	CIR-CLIP	STEEL
11	WASHER	ST ZINC
12	O-RING	NITRILE
13	WASHER	ST ZINC
14	SELF-LOCKING NUT	5.6 ZINC
15	O-RING	NITRILE
16	TIES	F-114 ZINC
17	WASHER	ST ZINC
18	NUT	5.6 ZINC
19	SCREW	5.6 ZINC
20	WASHER	ST ZINC
21	NUT	5.6 ZINC
22	SCREW	A-2
23	PROTECTION	S275JR

Table. 3

## STORAGE

To ensure the valve is in optimum conditions of use after long periods of storage, it should be stored in a well-ventilated place at temperatures below 30°C.

It is not advisable, but if it is stored outside, the valve must be covered to protect it from heat and direct sunlight, with good ventilation to prevent humidity. The following aspects must be considered for storage purposes:

- The storage place must be dry and under cover.
- It is not recommended to store the equipment outdoors with direct exposure to adverse weather conditions, such as rain, wind, etc. Even less so if the equipment is not protected with packaging.
- This recommendation is even more important in areas with high humidity and saline environments. Wind can carry dust and particles which can come into contact with the valve's mobile parts and this can lead to operating difficulties. The actuator system can also be damaged due to the introduction of particles in the different elements.
- The equipment must be stored on a flat surface to avoid deformations.
- If the equipment is stored without suitable packaging it is important to keep the valve's mobile parts lubricated, for this reason it is recommended to carry out regular checks and lubrication.
- Likewise, if there are any machined surfaces without surface protection it is important for some form of protection to be applied to prevent the appearance of corrosion.

## COMPONENTS LIST

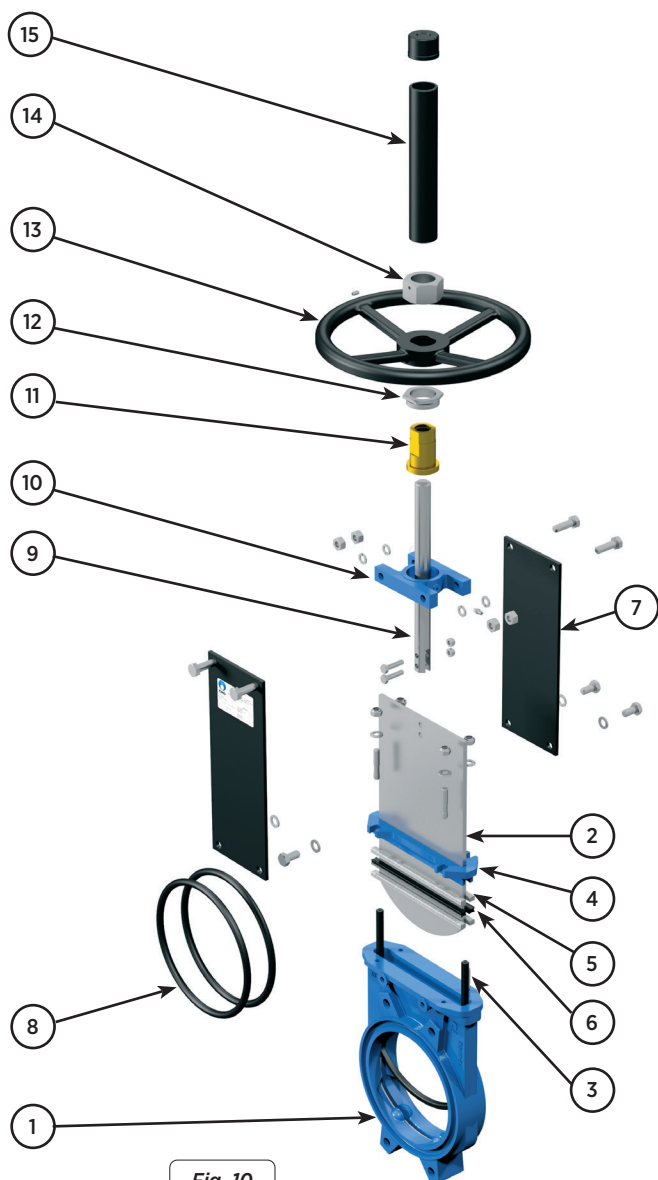

Fig. 10

HANDWHEEL DRIVE	
POS.	DESCRIPTION
1	BODY
2	GATE
3	SEALING JOINT
4	PACKING GLAND
5	GASKET
6	PACKING SEAL
7	SUPPORT PLATE
8	O-RINGS
9	STEM
10	YOKE
11	STEM NUT
12	NUT
13	HANDWHEEL
14	HOOD NUT
15	HOOD

Table. 4



[www.cmovalves.com](http://www.cmovalves.com)



**CMO** VALVES

QMS CERTIFIED BY LRQA  
Approval number ISO9001 0035593

**CMO VALVES**  
HEADQUARTERS MAIN  
OFFICES & FACTORY

Amategi Aldea, 142  
20400 Tolosa  
Gipuzkoa (Spain)

Tel.: (+34) 943 67 33 99

[cmo@cmovalves.com](mailto:cmo@cmovalves.com)  
[www.cmovalves.com](http://www.cmovalves.com)

**CMO VALVES**  
MADRID

C/ Rumania, 5 - D5 (P.E. Inbisa)  
28802 Alcalá de Henares  
Madrid (Spain)

Tel.: (+34) 91 877 11 80

[cmomadrid@cmovalves.com](mailto:cmomadrid@cmovalves.com)  
[www.cmovalves.com](http://www.cmovalves.com)

**CMO VALVES**  
FRANCE

5 chemin de la Brocardière  
F-69570 DARDILLY  
France

Tel.: (+33) 4 72 18 94 44

[cmofrance@cmovalves.com](mailto:cmofrance@cmovalves.com)  
[www.cmovalves.com](http://www.cmovalves.com)