

AB SERIES

BIDIRECTIONAL WAFER TYPE KNIFE GATE VALVE

DESCRIPTION

- Bidirectional valve with one-piece cast body and seat inserted in valve.
- Stainless steel gate.
- High flow rates with low load losses.
- Various constructions materials and seal and packing materials available.
- Face-to-face distance in accordance with **CMO Valves** standards.

GENERAL APPLICATIONS

This knife gate valve is suitable for liquids that contain a maximum of 4% suspended solids. If it is used for dry solids in gravity feed applications it should be installed with the arrow on the body pointing in the opposite direction to the flow.

Designed for applications such as:

- Industry.
- Chemical plants.
- Pumping.
- Food industry.
- Clean water treatment.

SIZES

From DN50 to DN600.

Other DN's on request.

WORKING PRESSURE (ΔP)

DN50-DN200	10 bar
DN250-DN400	6 bar
DN450	5 bar
DN500	4 bar
DN600	3 bar

Other pressures on request.

FLANGE DRILLING

- EN1092 PN10.
- ASME B16.5 (class 150).

OTHERS COMMONLY USED

- PN6.
- PN16.
- PN25.
- BS "D" and "E".
- JIS10K.

Others on request.

RESILIENT SEALS

- EPDM.
- NITRILE.
- FKM.
- SILICONE.

In some applications other types of resilient materials are used, such as hypalon, butile or natural rubber. Please contact us if you have such requirements.

DIRECTIVES

See document of directives applicable to **CMO Valves**.



*For further information on categories and zones please contact **CMO Valves**. Technical-Commercial Department.*

QUALITY DOSSIER

All valves are tested hydrostatically at **CMO Valves** and material and test certificates can be provided.

- Body test = working pressure x 1.5.
- Seal test = working pressure x 1.1.



AB SERIES

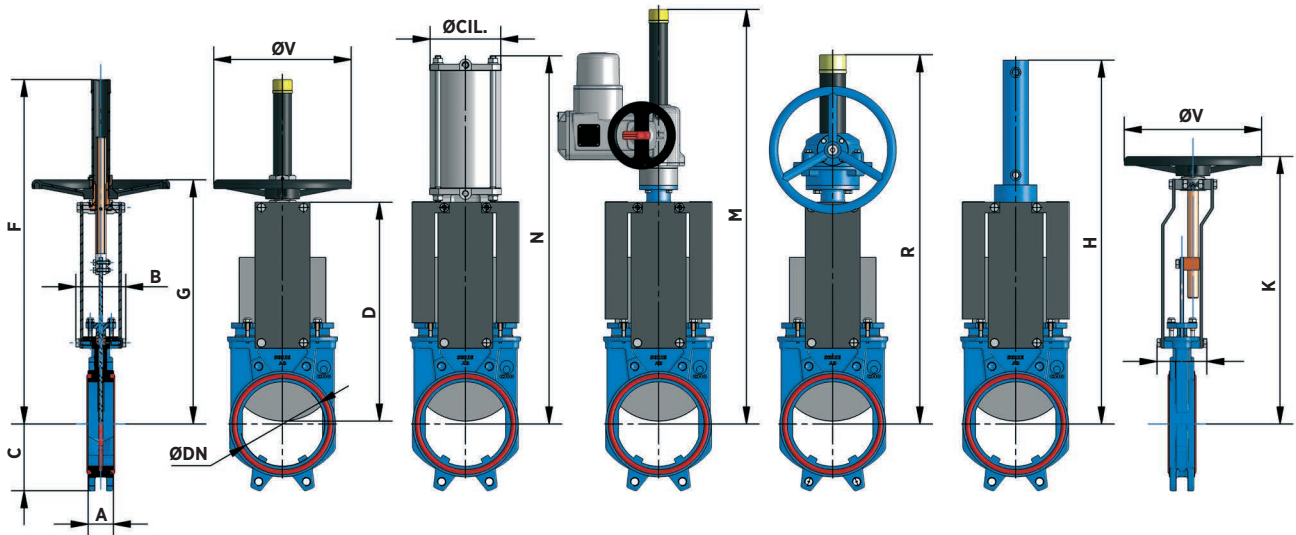

MANUFACTURING RANGE

DIMENSIONS - AB

DN	A	B	C	D	F	G	ØV	N	ØCIL	M	R	H	J	K
50	40	91	61	241	410	280	225	400	80	587	540	457	101	280
65	40	91	68	268	437	308	225	442	80	614	566	500	101	308
80	50	91	91	294	463	333	225	483	80	640	592	560	101	333
100	50	91	104	334	503	373	225	546	100	680	632	620	101	373
125	50	101	118	367	586	407	225	630	125	713	665	683	111	407
150	60	101	130	419	638	458	225	692	125	765	717	755	111	458
200	60	118	159	525	816	578	325	869	160	880	942	926	128	578
250	70	118	196	626	1017	679	325	1032	200	981	1033	1077	128	679
300	70	118	230	726	1117	779	380	1182	200	1141	1121	1246	128	779
350	96	290	254	797	1337	906	450	1379	250	1347	1305	1376	305	906
400	100	290	287	903	1443	1012	450	1535	250	1550	1403	1532	305	1012
450	106	290	304	989	1629	1098	450	1677	300	1847	1677	1707	305	1098
500	110	290	340	1101	1741	1210	450	1839	300	1959	1789	1869	305	1210
600	110	290	398	1307	2047	1416	450	2145	300	2165	1995	2176	305	1416

No obligation consultation on dimensions and drawings. CMO Valves reserves the right to modify them at any time, at its discretion and without prior notice.

Larger sizes on request.

www.cmovalves.com/valves



Visit our website to see the full features of the a AB Series.

FLANGE DRILLING - AB

DN	ΔP (bar)	PN10					ASA150				
		●	○	M	P	ØK	●	○	R UNC	P	ØK
50	10	4	-	M 16	8	125	4	-	5/8"	8	120,6
65	10	4	-	M 16	8	145	4	-	5/8"	8	139,7
80	10	4	4	M 16	9	160	4	-	5/8"	9	152,4
100	10	4	4	M 16	9	180	4	4	5/8"	9	190,5
125	10	4	4	M 16	9	210	4	4	3/4"	9	215,9
150	10	4	4	M 20	10	240	4	4	3/4"	10	241,3
200	10	4	4	M 20	10	295	4	4	3/4"	10	298,4
250	10	6	6	M 20	12	350	6	6	7/8"	12	361,9
300	6	6	6	M 20	12	400	6	6	7/8"	12	431,8
350	6	12	4	M 20	21	460	8	4	1"	21	476,2
400	6	12	4	M 24	21	515	12	4	1"	21	539,7
450	5	16	4	M 24	22	565	12	4	1 1/8"	22	577,8
500	4	16	4	M 24	22	620	16	4	1 1/8"	22	635
600	4	16	4	M 27	22	725	16	4	1 1/4"	22	749,3

Larger sizes on request.

- Threaded holes.
- Through holes.

