











<p><b>Page A 2</b></p>	<p><b>E3 Flange gate valve</b> Standard DN 50 – 600 Reductions E-valve DN 20 – 40</p>	<p>Page A 2/3 Page A 2/7 Page J 3/1</p>	
<p><b>Page A 3</b></p>	<p><b>E3 Valve spigot ends</b> <b>E3 Valve spigot ends</b> With flange</p>	<p>Page A 3/1 Page A 3/3</p>	
<p><b>Page A 4</b></p>	<p><b>E3 Valve for PE and PVC pipes</b> Valve system 2000 socket-socket Valve system 2000 socket-flange Valve system BAIO socket-socket Valve for PE fusion PE-PE Valve for PE fusion PE-flange</p>	<p>Page F 2/3 Page F 2/5 Page G 3/1 Page A 4/1 Page A 4/3</p>	
<p><b>Page A 5</b></p>	<p><b>E3 Valve for ductile iron pipes</b> Valve system BAIO socket-socket Valve system BAIO socket-spigot Valve system VRS socket-spigot</p>	<p>Page G 3/1 Page G 4/1 Page A 5/1</p>	
<p><b>Page A 6</b></p>	<p><b>E3 Combi-T</b> Combi-T with flange Combi-T System 2000 socket Combi-T System BAIO socket</p>	<p>Page A 6/1 Page F 3/1 Page G 5/1</p>	
<p><b>Page A 7</b></p>	<p><b>E3 Combi-III</b> Combi-III with flange Combi-III system BAIO</p>	<p>Page A 7/1 Page G 5/2</p>	
<p><b>Page A 8</b></p>	<p><b>E3 Combi-IV</b> Combi-IV with flange</p>	<p>Page A 8/1</p>	
<p><b>Page A 9</b></p>	<p><b>E3 Hawle-Combiflex</b> With flange DN 150 With flange DN 250, DN 300</p>	<p>Page A 9/1 Page A 9/5</p>	
<p><b>Page A 10</b></p>	<p><b>Hawle-E1+ valve</b></p>	<p>Page A 10/1</p>	
<p><b>Page A 11</b></p>	<p><b>Hawle-E2 valve</b> With flange DN 450 – 600</p>	<p>Page A 11/1</p>	

# E3 Gate valve

## Overview

- Medium: Water, seawater, gas\*
- In accordance to EN 1074-1 and -2

## Advantages Hawle-E3 Gate valve

- O-ring carrier with double bayonet (up to DN 200) or heavy-duty O-ring carrier with centering flange (> DN 200) in inside and outside fully coated bonnet
- POM sliding disks (up to DN 200) and an additional axial ball bearing (> DN 200) ensure low torque actuation
- Duplex stainless steel spindle
- Extended edge protection
- Wedge and wedge nut fully coated with vulcanized elastomer
- The wedge is connected to the wedge nut with a flexible link and embedded in elastomer. This snug fit dampens vibration during opening and closing of the wedge
- Stainless steel allen screws in bonnet
- 100% corrosion protection
- E3 bonnets are entirely compatible with all E2 bodies and accessories
- Full straight bore – suitable for pigging the pipeline
- Spindle O-rings replaceable under operating pressure up to DN 400
- All components made in the EU, including ductile iron parts

## Hawle-quality Guarantee



# E3 Gate valve | Combi valves

## Overview

### Design features

- Resilient seated gate valve according to EN 1171, EN 1074-1 and EN 1074-2 with smooth, straight-through bore
- Double bayonet O-ring carrier is connecting the spindle to the bonnet, allowing a fully encased, uniform epoxy powder coated bonnet for further improved corrosion protection
- Wedge guide made of wear resistant POM material in load optimized design minimizes attrition and ensures lowest torque actuation
- Wedge is flexible and fully linked in vulcanized elastomer to the wedge nut. This snug fit dampens vibration during opening and closing of the wedge
- Wedge nut has a long thread length allowing significantly higher torques than the standard before breaking
- O-rings, lip-seals mounted in the bonnet are replaceable under operating pressure
- Extended edge protection to avoid damages during transport, storage and assembly
- Sliding disks and ball bearing assure low friction performance of the spindle
- 100% suitable for buried installations

### Material | Technical features

- 1,2 Body (1), bonnet (2), centering flange (16) made of ductile iron, epoxy powder coated inside and out
- 3 Wedge made of ductile iron (DN 50 made of dezincification-resistant brass) with vulcanized elastomer all-over
- 4 Wedge guide made of wear-resistant plastic
- 5 Wedge nut made of dezincification-resistant brass
- 6 Duplex stainless steel spindle with rolled thread and flat-rolled anti-friction surface
- 7 O-ring carrier made of brass, DN 50 – 200 with double bayonet
- 8 O-rings made of elastomer
- 9 Wiper ring made of PE
- 10 Bonnet gasket made of elastomer
- 11 Allen screws made of stainless steel, encased into the body with interlacing gasket and sealing compounds, ensuring full corrosion protection
- 12 Extended edge protection made of PE
- 13 Spindle bearing made of dezincification resistant brass
- 14 Sliding disks made of POM
- 15 Safety screw made of stainless steel
- 17 Centering flange gasket made of elastomer
- 18 Axial ball bearing permanently lubricated
- 19 Centering ring made of POM
- 20 Lip seals made of elastomer
- 21 Wiper ring made of elastomer

### DN 50 – 200

Spindle bearing with sliding disks

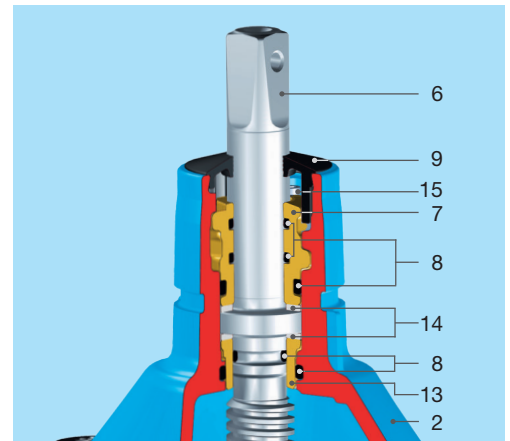

### DN 250 – 400 Spindle bearing with ball bearing and additional sliding disks

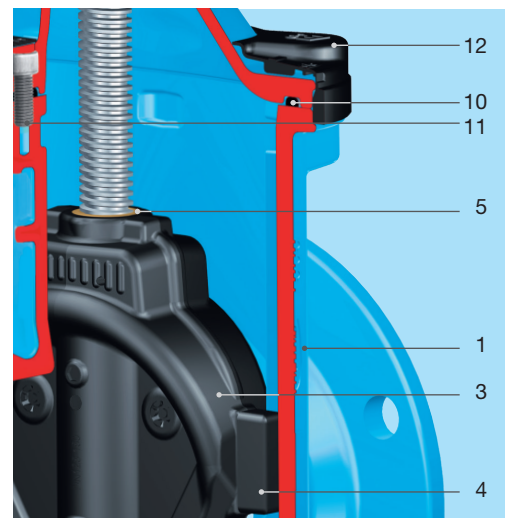
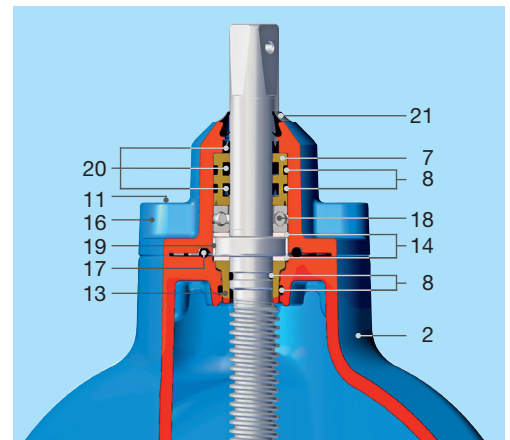

DN 500 – 600 in preparation - currently available - see page A 11/3

# Valves | Combi valves

## Accessories

Handwheels	Page M 4/1
Extension spindles	Page M 2/1
Surface boxes	Page M 3/1
Base plate	Page M 3/7
Adapter and coupling socket	Page M 4/3
Operating cap	Page M 4/1
Spindle extension	Page M 4/1
Actuator	Page M 4/3
Position indicator	Page M 4/2
Bolts	Page M 4/4
HAWAK-pillar	Page M 5/1
Flat gaskets	Page M 7/1
Blanking cap	Page M 4/1
Flanges	Page C 4/1
Dismantling pieces	Page D 6/1

## Tools

Operating key	Page Q 4/2
---------------	------------

## Technical information

Tightening torques for flange assembly	Page R 3/1
Pressure loss diagram	Page R 4/1
Spindle rotations per stroke	Page R 1/2

## Application examples



# E3 Gate valve

With flange DN 50 – 200, PN 10 | PN 16 | PN 25



## Design features

- Resilient seated gate valve with smooth straight-through bore
- Flanges sized in accordance with EN 1092-2, drilled according to  
EN 1092-2 | PN 10 standard (4000E3, 4700E3);  
EN 1092-2 | PN 16 from DN 200 (4000E3, 4700E3)  
EN 1092-2 | PN 25 (4010E3, 4710E3)  
Please specify on order - other standards on request
- Suitable for cleaning with a cleaning pig
- One extension spindle for several dimensions
- Suitable for operation by automatic actuators
- Easy retrofitting of position indicator and automatic actuators on the standard bonnet
- Duplex stainless steel spindle

**Standard version:** without handwheel and extension spindle

**Design versions:**

for actuator:	No. 4000ELE3
with actuator:	No. 4000EME3
with position indicator:	No. 4000STE3
for seawater:	No. 4002E3, No. 4702E3

**Special versions:** on request

No. 4000E3

No. 4700E3

No. 4010E3

No. 4710E3\*

No. 4060E3\*



## Suitable accessories

**Suitable accessories:** see page A 2/2

Handwheel:		No. 7800
Extension spindles:	rigid	No. 9000E2/E3
	telescopic	No. 9500E2/E3
Surface boxes:	rigid	No. 1750
	telescopic	No. 2050
		No. 2051K
Valve actuator:		No. 9920
Adapter for actuator (E2/E3 adapter):		No. 8630E2/E3
Base plate:	No. 3481, No. 3482	
Operating cap:	No. 2156, No. 2157, No. 2158	
Extension spindle:	No. 7820, No. 7825	
Position indicator:	No. 2170E2/E3	
Bolts:	No. 8810, No. 8830, No. 8840	
HAWAK-pillar:	No. 9894, No. 9895	
Flat gasket:	No. 3390, No. 3470	

Order no.	Version	MOP (PN)	Dimensions/DN						
			50	65	80	100	125	150	200
4000E3	short EN 558 GR 14	16							
4700E3	long EN 558 GR 15	16							
4010E3	short EN 558 GR 14	25							
4710E3*	long EN 558 GR 15	25							
4060E3*	to BS 5163 to AS 2638	16			*	*		*	*

\*in preparation

## Application examples



# E3 Gate valve

With flange DN 50 – 200, PN 10 | PN 16 | PN 25

No. 4000E3

No. 4700E3

No. 4010E3

No. 4710E3\*

No. 4060E3\*

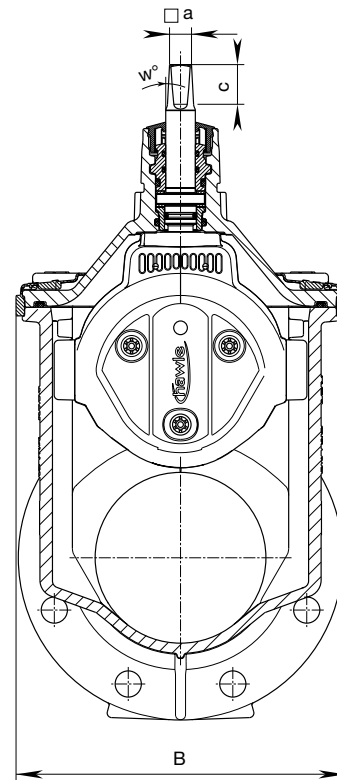
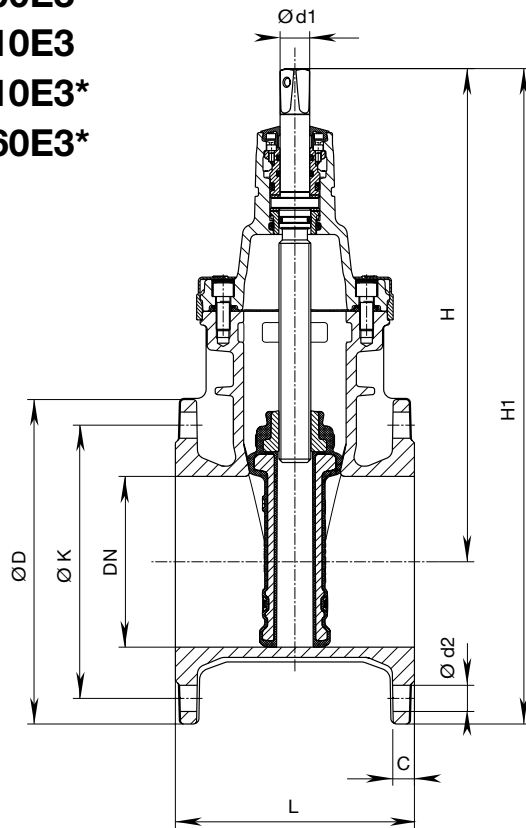

DN	MOP (PN)	Flange			Bolts			Spindle			Valve						Weight			
		ØD	C	ØK	Qty.	Thread	Ød2	□ a	c	w°	Ød1	H	H1	L short	L long	L BS 5163 AS 2638	B	short	long	BS 5163 AS 2638
50	10																	10,0	11,5	10,7
	16	165	19	125	4	M 16	19	14,8	33		20,5	234	316,5	150	250	178	143	10,0		
	25																			
65	10																	15,5	17,5	
	16	185	19	145	4	M 16	19	17,3	35		24	305	397,5	170	270		180	16,0		
	25*				8															
80	10																	16,5	20,0	18,0
	16	200	19	160	8	M 16	19	17,3	38		24	312,5	412,5	180	280	203	180	18,0		
	25*																			
100	10																	20,5	25,5	23,5
	16	220	19	180	8	M 16	19	19,3	39	3°	24	343	453	190	300	229	212	24,5		
	25*	235		190		M 20	23						460							
125	10																	33,0	37,5	
	16	250	19	210	8	M 16	19	19,3	39		26	421	546	200	325		289	34,0		
	25*	270		220		M 24	28						556							
150	10																	37,0	43,5	41,0
	16	285	19	240	8	M 20	23	19,3	39		26	433	576	210	350	267	289	47,0	49,0	
	25*	300		250		M 24	28						583							
200	10				8													60,5	71,5	65,0
	16	340	20	295	12	M 20	23	24,3	49		30	541	711	230	400	292	356	67,0	79,0	
	25*	360		310	12	M 24	28						721							

\*in preparation

# E3 Gate valve

With flange DN 250 – 400, PN 10 | PN 16 | PN 25



## Design features

- Resilient seated gate valve with smooth straight-through bore
- Flanges sized in accordance with EN 1092-2, drilled according to  
EN 1092-2 | PN 10 standard (4000E3, 4700E3);  
EN 1092-2 | PN 16 from DN 200 (4000E3, 4700E3);  
EN 1092-2 | PN 25 (4710E3)  
Please specify on order - other standards on request
- Suitable for cleaning with a cleaning pig
- Suitable for operation by automatic actuators
- O-rings lip-seals replaceable under operating pressure up to DN 400
- Ball bearings in the spindle seating minimizes closing forces
- Easy to actuate without bypass and without power boost - even for 16 bar differential pressure
- For mounting a position indicator it is necessary to remove the centering flange and attach the adapter for position indicator

**Standard version:** without handwheel and extension spindle

**Design versions:**

for actuator:	No. 4000ELE3
with actuator:	No. 4000EME3
with position indicator:	No. 4000STE3
for seawater:	No. 4002E3, No. 4702E3

**Special versions:** on request  
- Bevel gearing

**No. 4000E3**  
**No. 4700E3**  
**No. 4710E3**  
**No. 4060E3\***



## Suitable accessories

**Suitable accessories:** see page A 2/2

Handwheel:	No. 7800
Extension spindles:	rigid No. 9000E2/E3 telescopic No. 9500E2/E3
Surface boxes:	rigid No. 1750 telescopic No. 2050 No. 2051K
Valve actuator:	No. 9920
Adapter for actuator (E3 adapter):	No. 8630E3
Base plate:	No. 3481, No. 3482
Operating cap:	No. 2156, No. 2157, No. 2158
Extension spindle:	No. 7820, No. 7825
Bolts:	No. 8810, No. 8830, No. 8840
HAWAK-pillar:	No. 9894, No. 9895
Flat gasket:	No. 3390, No. 3470

Order no.	Version	MOP (PN)	Dimensions/DN					
			250	300	350	400	500*	600*
4000E3	short EN 558 GR 14	16					*	*
4700E3	long EN 558 GR 15	16					*	*
4710E3	long EN 558 GR 15	25						
4060E3	to BS 5163 to AS 2638	16						

\*in preparation - currently available in E2 version, see page A 11/3

# E3 Gate valve

With flange DN 250 – 400, PN 10 | PN 16 | PN 25

- No. 4000E3
- No. 4700E3
- No. 4710E3
- No. 4060E3\*

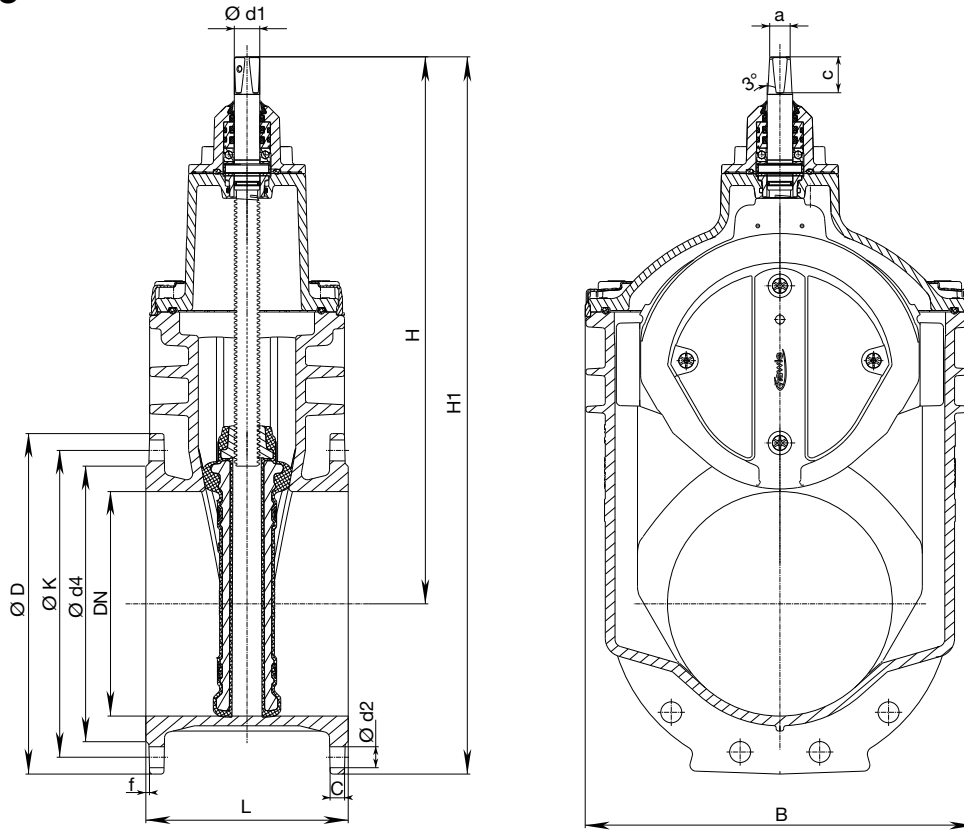

DN	MOP (PN)	Flange					Bolts			Spindle			Valve						Weight		
		Ø D	C	Ø K	Ø d4	f	Qty.	Thread	Ø d2	a	c	Ø d1	H	H1	L short	L long	<sup>L</sup> <sub>BS 5163</sub> <sub>AS 2638</sub>	B	short	long	BS 5163 AS 2638
250	10																		98,5	114,5	109,0
	16	400	22	350	319	3	12	M 20	23	27,3	48	34	649	849	250	450	330	436	102,0	110,0	
	25	425	24,5	370	330			M 27	31					862					136,0		
300	10																		151,0	169,5	167,0
	16	455	24,5	400	367	4	12	M 20	23	27,3	48	34	731	958	270	500	356	520	150,0	169,0	
	25	485	27,5	430	389	5	16	M 27	31					973					196,0		
350	10																				
	16	520	26,5	460	427	4	16	M 20	23	27,3	48	34	816	1076	290			604	205,5		
400	10																				
	16	580	28	515	477	4	16	M 24	28	32,3	55	44	925	1215	310	600	406	687	266,0	310,0	
450	10																				
	16																				
500	10*																				
	16*																				
600*	10*																				
	16*																				

\*in preparation - currently available in E2 version, see page A 11/3



# E3 Reducing valve

## With flange DN 65 – 300, PN 10 | PN 16



### Design features

- Resilient seated gate valve with unequal flange sizes
- Flanges sized in accordance with EN 1092-2, drilled according to EN 1092-2 | PN 10 standard; EN 1092-2 | PN 16 DN 200 please specify on order - other standards on request
- This E3 reduction valve is a gate valve and a reducing connector in one piece; this feature provides for a multitude of application possibilities for the most efficient material and space requirements
- One extension spindle for several dimensions
- Suitable for operation by automatic actuators
- Easy retrofitting of position indicator and automatic actuators on the standard bonnet
- Duplex stainless steel spindle

No. 4150E3



**Standard version:** without handwheel and extension spindle

**Design versions:** for actuator: No. 4150ELE3  
with position indicator: No. 4150STE3

**Special versions:** on request

### Suitable accessories

**Suitable accessories:** see page A 2/2

Handwheel:		No. 7800
Extension spindles:	rigid	No. 9000E2/E3
	telescopic	No. 9500E2/E3
Surface boxes:	rigid	No. 1750
	telescopic	No. 2050 No. 2051K No. 9920
Valve actuator:		No. 9920
Adapter for actuator (E2/E3 adapter):		No. 8630E2/E3
Base plate:		No. 3481, No. 3482
Operating cap:		No. 2156, No. 2157, No. 2158
Extension spindle:		No. 7820, No. 7825
Position indicator:		No. 2170E2/E3
Bolts:		No. 8810, No. 8830, No. 8840
HAWAK-pillar:		No. 9894, No. 9895
Flat gasket:		No. 3390, No. 3470

Order no.	MOP (PN)	Dimensions/DN*													
		100 65	100 80	125 80	125 100	150 80	150 100	150 125	200 100	200 150	250 150	250 200	300 150	300 200	300 250
4150E3	16														

\* The valve is sized in accordance with the smaller flange

# E3 Reducing valve

## With flange DN 65 – 300, PN 10 | PN 16

No. 4150E3

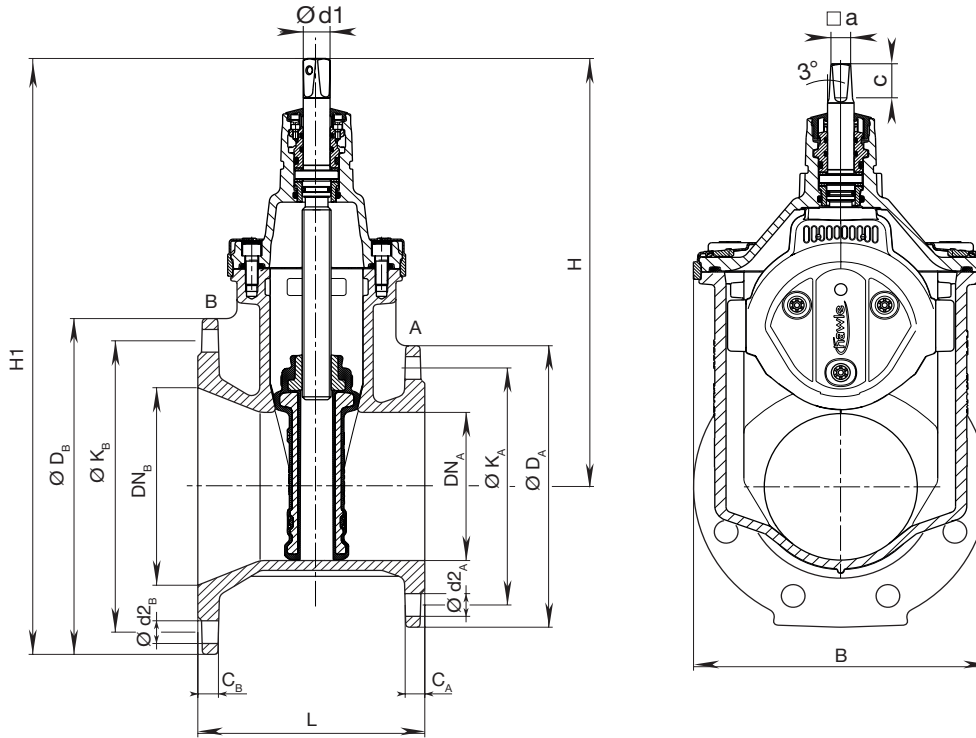

DN	MOP (PN)	Flange A					Flange B					Spindle			Valve				Weight
		ØD <sub>A</sub>	C <sub>A</sub>	ØK <sub>A</sub>	Ød <sub>2A</sub>	n <sub>A</sub> *	ØD <sub>B</sub>	C <sub>B</sub>	ØK <sub>B</sub>	Ød <sub>2B</sub>	n <sub>B</sub> *	a	c	Ød1	H	H1	L	B	
100 – 65	10 16	185	19	145	19	4	220	19,0	180	19	8	17,3	35	25	305	415	180	180	18,0
100 – 80	10 16	200	19	160	19	8	220	19,0	180	19	8	17,3	35	25	313	423	190	180	19,5
125 – 80	10 16	200	19	160	19	8	250	19,0	210	19	8	17,3	35	25	313	438	200	180	21,5
125 – 100	10 16	220	19	180	19	8	250	19,0	210	19	8	19,3	38	25	343	468	200	213	24,0
150 – 80	10 16	200	19	160	19	8	285	19,0	240	23	8	17,3	35	25	313	456	200	180	24,0
150 – 100	10 16	220	19	180	19	8	285	19,0	240	23	8	19,3	38	25	343	486	210	213	26,5
150 – 125	10 16	250	19	210	19	8	285	19,0	240	23	8	19,3	38	28	421	564	210	285	36,0
200 – 100	10 16	220	19	180	19	8	340	20,0	295	23	8 12	19,3	38	25	343	513	210	213	29,0
200 – 150	10 16	285	19	240	23	8	340	20,0	295	23	8 12	19,3	38	28	433	603	220	285	42,5
250 – 150	10 16	285	19	240	23	8	400	22,0	350 355	23 28	12	19,3	38	28	433	633	230	285	49,0
300 – 150	10 16	285	19	240	23	8	455	24,5	400 410	23 28	12	19,3	38	28	433	661	240	285	68,0
250 – 200	10 16	340	20	295	23	8 12	400	22,0	350 355	23 28	12	24,3	48	32	541	741	240	357	69,0
300 – 200	10 16	340	20	295	23	8 12	455	24,5	400 410	23 28	12	24,3	48	32	541	769	250	357	74,0
300 – 250	10 16	400	22	350 355	23 28	12	455	24,5	400 410	23 28	12	27,3	48	34	649	877	260	432	105,0

The valve is sized in accordance with the smaller flange nA\*, nB\* = bolts per flange

# E3 Valve spigot ends

## PN 16

### Design features

- Resilient seated gate valve with smooth straight-through bore
- The Hawle E3 spigot valve with smooth spigot ends is a universal type, suitable for both flange as well as for socket connections
- Easy replacement of old flange valve to insertion of HAWLE-flange, as insertion of flat gaskets is not required; special lengths can even be produced through shortening of the spigot ends
- The outside diameters of the spigot ends correspond to that of the cast iron pipes (other size on request)
- Suitable for cleaning with a cleaning pig
- One extension spindle for several dimensions
- Suitable for operation by automatic actuators
- Easy retrofitting of position indicator and automatic actuators on the standard bonnet

**Standard version:** without flanges, handwheel and extension spindle

### No. 4100E3

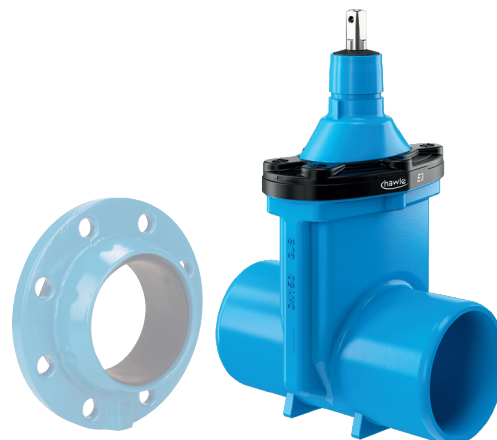

### No. 4140E3



### Suitable accessories

**Suitable accessories:** see page A 2/2

Flange:		No. 7102
		No. 0102
Handwheel:		No. 7800
Extension spindles:	rigid	No. 9000E2/E3
	telescopic	No. 9500E2/E3
Surface boxes:	rigid	No. 1750
	telescopic	No. 2050
		No. 2051K
Valve actuator:		No. 9920
Adapter for actuator (E2/E3 adapter):		No. 8630E2/E3
Base plate:	No. 3481, No. 3482	
Operating cap:	No. 2156, No. 2157, No. 2158	
Extension spindle:	No. 7820, No. 7825	
Position indicator:	No. 2170E2/E3	
Bolts:	No. 8810, No. 8830, No. 8840	
HAWAK-pillar:	No. 9894, No. 9895	

Order no.	Version Face-to-face length	MOP (PN)	Dimensions/DN										
			50	65	80	100	125	150	200	250	300	400	
4100E3	Standard	16											*
	600 mm												
4140E3	810 mm												
	860 mm												

\*in preparation

# E3 Valve spigot ends

PN 16

No. 4100E3

No. 4140E3

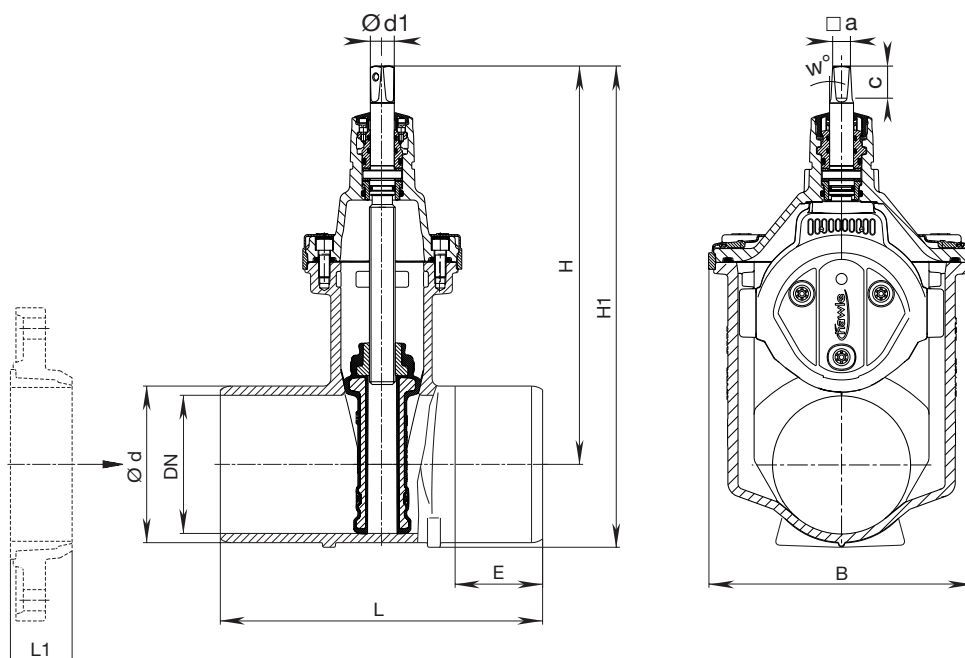

For a shorter face-to-face dimension, shorten the spigot ends<sup>1)</sup> and assemble with Hawle flanges No. 7102 / No. 0102 (see water catalogue chapter „Flange connections”)

**Caution:** Compare flange length „L 1” with spigot length „E”

<sup>1)</sup> Protect cutting surfaces against corrosion with Hawle repair material No. 3442 (see water catalogue page P 5/2)

DN	MOP (PN)	Valve						Spindle				Weight
		Ød*	L	E	H	H1	B	□ a	c	w°	Ød1	
50	16	66	250	80	234	270	143	14,8	30	3°	20,5	8,0
65		82	270	85	305	350	180	17,3	35		24	12,0
80		98	280	85	313	366,5	180	17,3	35		24	13,5
			600	245								
100		118	300	90	343	408	213	19,3	38		24	18,0
			600	240								
125		144	325	95	421	498	285	19,3	38		26	28,5
200		222	600	220	541	657	357	24,3	48		30	40,0
			250	274								
300		326			810	300	731	897	518		27,3	48
			400*	429	500	120						
400*		429			860	300	925	1149	687		32,3	55
			400*	429	500	120						
400*	429	860			300	925	1149	687	32,3	55	44	177,0
		400*	429	600	133							

\*in preparation

\*Other outside diameters on request

# E3 Valve spigot ends

## With flange, PN 10 | PN 16

### Design features

- Resilient seated gate valve with smooth straight-through bore
- Flanges sized in accordance with EN 1092-2, drilled according to EN 1092-2 | PN 10 standard; EN 1092-2 | PN 16 DN 200 please specify on order - other standards on request
- The Hawle E3 spigot ends valve with the high-tensile loose flange system is especially suitable for use with new builds in addition to being a replacement for existing valves
- The flat gaskets are already contained in the conical seals
- Suitable for cleaning with a cleaning pig
- One extension spindle for several dimensions
- Suitable for operation by automatic actuators
- Easy retrofitting of position indicator and automatic actuators on the standard bonnet

No. 4120E3

**Standard version:** without handwheel and extension spindle



### Suitable accessories

**Suitable accessories:** see page A 2/2

Handwheel:		No. 7800
Extension spindles:	rigid	No. 9000E2/E3
	telescopic	No. 9500E2/E3
Surface boxes:	rigid	No. 1750
	telescopic	No. 2050
		No. 2051K
Valve actuator:		No. 9920
Adapter for actuator (E2/E3 adapter):		No. 8630E2/E3
Base plate:	No. 3481, No. 3482	
Operating cap:	No. 2156, No. 2157, No. 2158	
Extension spindle:	No. 7820, No. 7825	
Position indicator:	No. 2170E2/E3	
Bolts:	No. 8810, No. 8830, No. 8840	
HAWAK-pillar:	No. 9894, No. 9895	

Order no.	Version	MOP (PN)	Dimensions/DN		
			100	150	200
4120E3	short EN 558 GR 14	16			

Face-to-face length EN 558 GR 15 on request

# E3 Valve spigot ends

With flange, PN 10 | PN 16

No. 4120E3

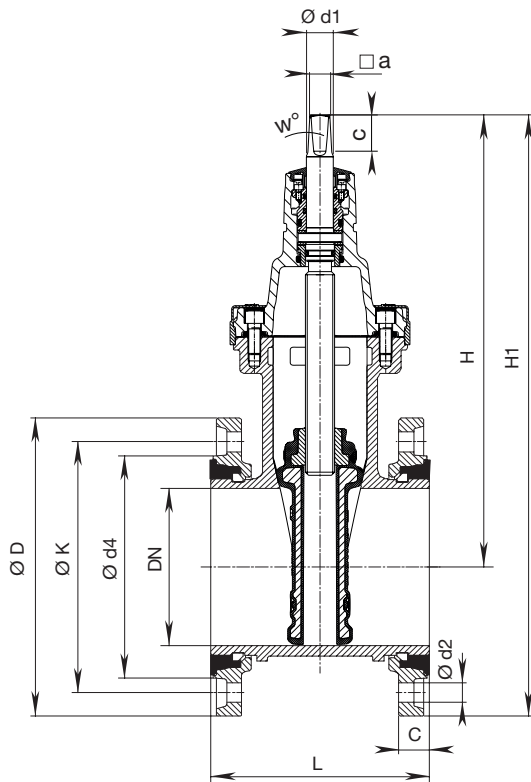

DN	MOP (PN)	Flange				Bolts			Spindle				Valve				Weight
		$\varnothing D$	C	$\varnothing K$	$\varnothing d4$	Qty.	Thread	$\varnothing d2$	$\square a$	c	$w^\circ$	$\varnothing d1$	H	H1	L	B max. width	
100	10	220	19	180	153	8	M 16	19	19,3	38		24	343	453	190	213	23,5
	16																
150	10	285	19	240	209	8	M 20	23	19,3	38	3°	26	433	576	210	285	40,0
	16																
200	10	340	20	295	264	8	M 20	23	24,3	48		30	541	711	230	357	61,0
	16																

# E3 Valve for PE fusion

## DN 50 – 200, PN 10 | PN 16



### Design features

- Resilient seated gate valve with PE fusion tails in combination with PE pipes according to EN 12201, DIN 8074
- This resilient seated valve has PE tails screwed and sealed into the sockets
- High performance sealing of the PE tails within the sockets is assured by two separate seals and a support liner
- The valve can be connected to the PE pipeline by either butt fusion or electrofusion
- One extension spindle for several dimensions
- Suitable for operation by automatic actuators
- Easy retrofitting of position indicator and automatic actuators on the standard bonnet
- Duplex stainless steel spindle

**Standard version:** without handwheel and extension spindle

**Special versions:** on request

**No. 4050E3**

**No. 4051E3**



### Material | technical features

#### 1 PE-fusion tail

Standard version PE 100-RC injection moulded  
**Support liner** DN 50 made of POM,  
 from DN 65 – DN 200 made of stainless steel for PE-fusion tail(see drawing)

2 **Socket sealing** made of elastomer

3 **O-Ring** made of elastomer

### Suitable accessories

**Suitable accessories:** see page A 2/2

Handwheel:		No. 7800
Extension spindles:	rigid	No. 9000E2/E3
	telescopic	No. 9500E2/E3
Surface boxes:	rigid	No. 1750
	telescopic	No. 2050, No. 2051K
Valve actuator:		No. 9920
Adapter for actuator (E2/E3 adapter):		No. 8630E2/E3
Base plate:		No. 3481, No. 3482
Operating cap:		No. 2156, No. 2157, No. 2158
Extension spindle:		No. 7820, No. 7825
Position indicator:		No. 2170E2/E3
HAWAK-pillar:		No. 9894, No. 9895

Order no.	MOP (PN)	Dimensions/DN Pipe Ø									
		50	65	80	100	100	125	150	150	200	200
4050E3	16										
4051E3	10										

**PE-fusion tail:** No. 4050E3 PN 16 / SDR 11  
 No. 4051E3 PN 10 / SDR 17  
 (No. 4051E3 PN 10 / SDR 17.6 on request)

# E3 Valve for PE fusion

DN 50 – 200, PN 10 | PN 16

No. 4050E3

No. 4051E3

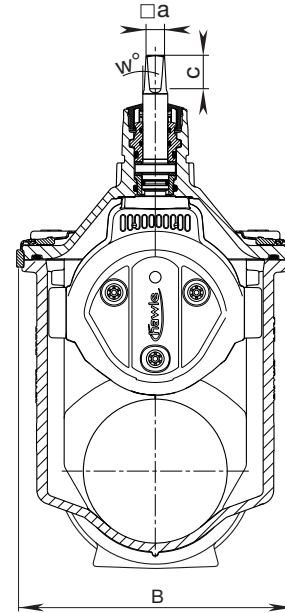
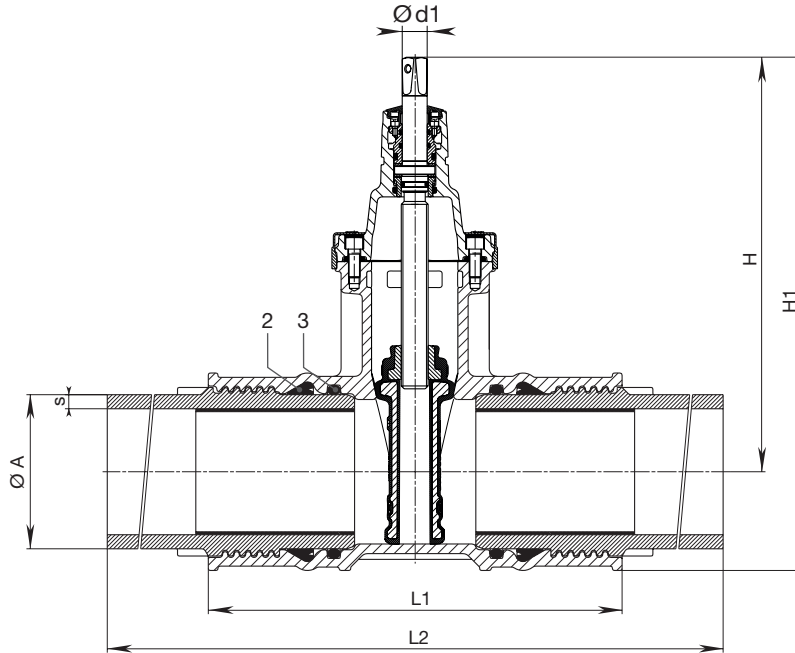

PE-fusion tail: No. 4050E3 PN 16 / SDR 11  
 No. 4051E3 PN 10 / SDR 17  
 (No. 4051E3 PN 10 / SDR 17.6 on request)

DN	ØA	Valve with PE tails							Spindle				Weight
		s (SDR 17)	s (SDR 11)	H	H1	L1	L2	B	□ a	c	w°	Ød1	
50	63	3,8	5,8	234	283	280	648	143	14,8	30	3°	20,5	11,0
65	75	4,5	6,8	305	361	295	657	180	17,3	35		24	17,0
80	90	5,4	8,2	313	377	310	668	180	17,3	35		24	19,0
100	110	6,6	10,0	343	419	340	710	213	19,3	38		24	26,0
100	125	7,4	11,4	343	428	395	761	213	19,3	38		24	30,5
125	140	8,3	12,7	421	513	390	756	285	19,3	38		26	31,5
150	160	9,5	14,6	433	536	430	796	285	19,3	38		26	50,0
150	180	10,7	16,4	433	548	458	814	285	19,3	38		26	57,5
200	200	11,9	18,2	541	679	514	900	357	24,3	48		30	88,0
200	225	13,4	20,5	541	679	514	900	357	24,3	48		30	90,0



# E3 Valve flange | PE tail

## DN 50 – 200, PN 10 | PN 16



### Design features

- Resilient seated gate valve with flange and PE fusion tail in combination with PE pipes according to EN 12201, DIN 8074
- This resilient seated valve has one flange and one PE tail screwed and sealed into the sockets
- High performance sealing of the PE tails within the sockets is assured by two separate seals and a support liner
- The valve can be connected to the PE pipeline by either butt fusion or electrofusion
- Flanges sized in accordance with EN 1092-2, drilled according to EN 1092-2 | PN 10 standard; EN 1092-2 | PN 16 DN 200 please specify on order - other standards on request
- One extension spindle for several dimensions
- Suitable for operation by automatic actuators
- Easy retrofitting of position indicator and automatic actuators on the standard bonnet
- Duplex stainless steel spindle

**No. 4090E3**  
**No. 4091E3**

**Standard version:** without handwheel and extension spindle  
**Special versions:** on request



### Material | technical features

#### 1 PE-fusion tail

Standard version PE 100-RC injection moulded  
**Support liner** DN 50 made of POM, from DN 65 – DN 200 made of stainless steel for PE-fusion tail (see drawing)

2 **Socket sealing** made of elastomer

3 **O-Ring** made of elastomer

### Suitable accessories

**Suitable accessories:** see page A 2/2

Handwheel: No. 7800  
Extension spindles: rigid No. 9000E2/E3  
telescopic No. 9500E2/E3  
Surface boxes: rigid No. 1750  
telescopic No. 2050, No. 2051K  
Valve actuator: No. 9920  
Adapter for actuator (E2/E3 adapter): No. 8630E2/E3  
Base plate: No. 3481, No. 3482  
Operating cap: No. 2156, No. 2157, No. 2158  
Extension spindle: No. 7820, No. 7825  
Position indicator: No. 2170E2/E3  
Bolts: No. 8810, No. 8830, No. 8840  
HAWAK-pillar: No. 9894, No. 9895  
Flat gasket: No. 3390, No. 3470

Order no.	MOP (PN)	Dimensions/DN Pipe Ø								
		50	65	80	100	100	125	150	150	200
4090E3	16	63	75	90	110	125	140	160	180	225
4091E3	10									

**PE-fusion tail:** No. 4090E3 PN 16 / SDR 11  
No. 4091E3 PN 10 / SDR 17  
(No. 4091E3 PN 10 / SDR 17.6 on request)

# E3 Valve flange | PE tail

DN 50 – 200, PN 10 | PN 16

No. 4090E3

No. 4091E3

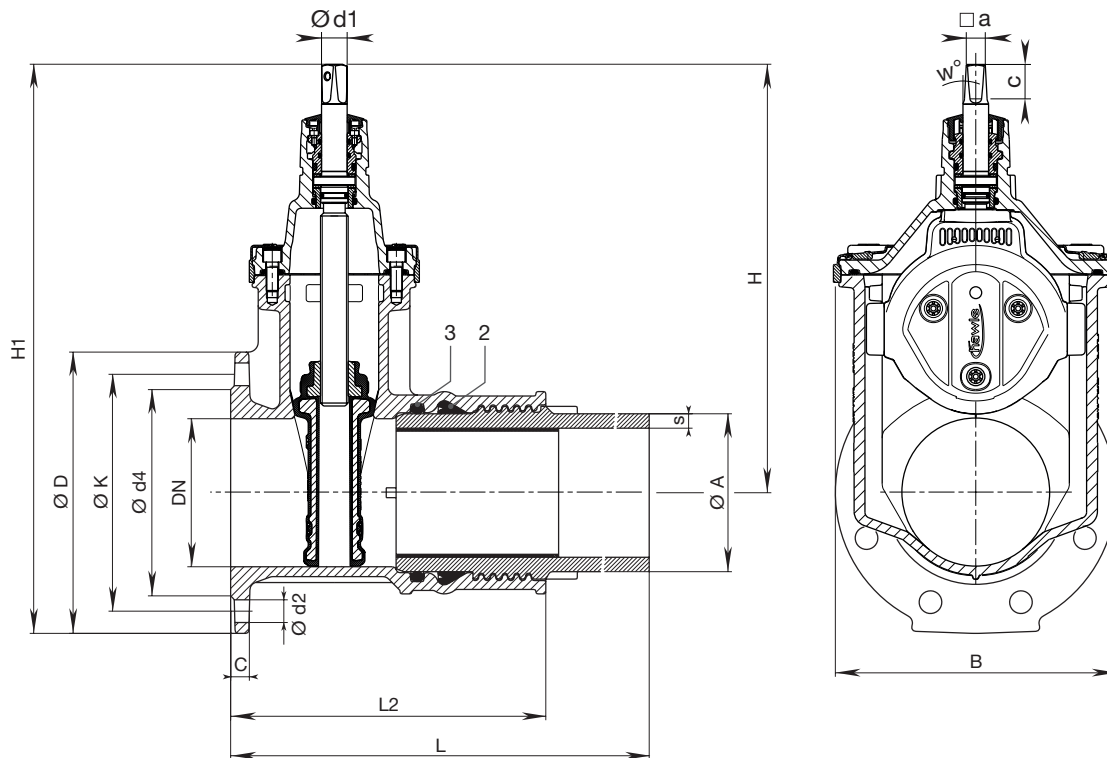

**PE-fusion tail:**

No. 4090E3 PN 16 / SDR 11  
 No. 4091E3 PN 10 / SDR 17  
 (No. 4091E3 PN 10 / SDR 17.6 on request)

DN	Ø Pipe	Flange				Bolts			Valve with PE tails						Spindle			Weight		
		ØD	C	ØK	Ød4	Qty.	Thread	Ød2	s (SDR 17)	s (SDR 11)	H	H1	L	L2	B	a	c		w°	Ød1
50	63	165	19	125	98	4	M 16	19	3,8	5,8	234	316	399	215	143	14,8	30	3°	20,5	11,5
65	75	185		145	118	4	M 16	19		6,8	305	397	416	235	180	17,3	35		24	17,0
80	90	200		160	133	8	M 16	19	5,4	8,2	313	413	425	245	180	17,3	35		24	18,0
100	110	220		180	153	8	M 16	19	6,6	10,0	343	453	450	265	213	19,3	38		24	25,0
100	125	220		180	153	8	M 16	19		11,4	343	453	476	293	213	19,3	38		24	26,5
125	140	250		210	183	8	M 16	19		12,7	421	546	485	310	285	19,3	38		26	38,0
150	160	285		240	209	8	M 20	23		14,6	433	576	503	320	285	19,3	38		26	44,5
150	180	285		240	209	8	M 20	23		16,4	433	576	512	334	285	19,3	38		26	49,5
200	225	340		20	295	264	8/12	M 20	23	13,4	20,5	541	711	565	372	357	24,3		48	30

# E3 VRS-socket valve

For cast iron pipes and pipes with VRS-socket,  
DN 80 – 300, PN 16

## Design features

- Resilient seated gate valve with one-sided VRS-socket and one-sided VRS-spigot
- With VRS grip ring and VRS pipe restraint clamp (not included), a pipe connection can be made restraint
- Suitable for cleaning with a cleaning pig
- One extension spindle for several dimensions
- Suitable for operation by automatic actuators
- Easy retrofitting of position indicator and automatic actuators on the standard bonnet
- Duplex stainless steel spindle

No. 4027E3

**Standard version:** without handwheel and extension spindle



## Material | technical features

- 1 **Socket sealing** made of elastomer
- 2 **Pipe restraint clamp** (not included)

## Suitable accessories

**Suitable accessories:** see page A 2/2

Handwheel:		No. 7800
Extension spindles:	rigid	No. 9000E2/E3
	telescopic	No. 9500E2/E3
Surface boxes:	rigid	No. 1750
	telescopic	No. 2050, No. 2051K
Valve actuator:		No. 9920
Adapter for actuator (E2/E3 adapter):		No. 8630E2/E3
Base plate:		No. 3481, No. 3482
Operating cap:		No. 2156, No. 2157, No. 2158
Extension spindle:		No. 7820, No. 7825
Position indicator:		No. 2170E2/E3
HAWAK-pillar:		No. 9894, No. 9895

Order no.	Version	MOP (PN)	Dimensions/DN						
			80	100	125	150	200	250	300
4027E3	Socket-Spigot	16							

# E3 VRS-socket valve

For cast iron pipes and pipes with VRS-socket,  
DN 80 – 300, PN 16

No. 4027E3

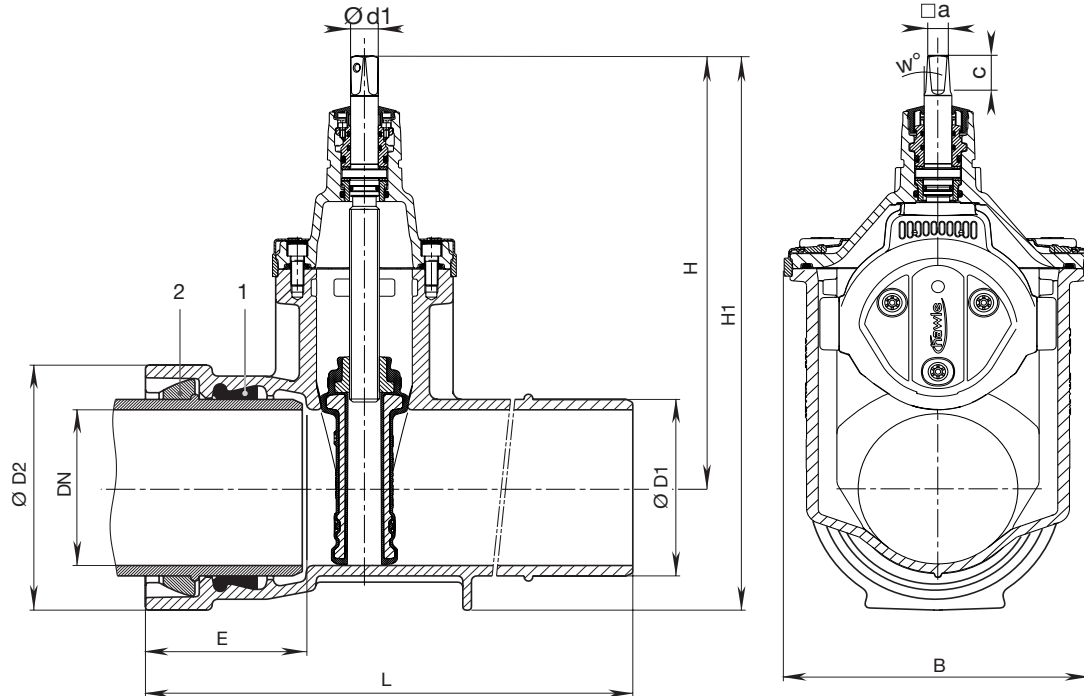

DN	Ø Pipe	MOP (PN)	Valve							Spindle				Weight
			ØD1	ØD2	E	H	H1	L	B	□ a	c	w°	Ød1	
80	98	16	98	156	127	313	391	422	180	17,3	35	3°	24	20,5
100	118		118	178	135	343	432	440	213	19,3	38		24	24,5
125	144		144	208	143	421	525	494	285	19,3	38		24	37,5
150	170		170	235	150	433	551	513	285	19,3	38		26	44,5
200	222		222	295	160	541	689	535	357	24,3	48		30	72,0
250	274		274	356	165	649	827	577	432	27,3	48		36	114,0
300	326		326	414	170	731	938	638	518	27,3	48		36	168,5

# E3 Combi-T

## Flange T-piece with integrated E3-valve, PN 10 | PN 16



### Design features

- Resilient seated gate valve combined with flange T-piece
- Short style, equal and reduced
- Space saving installation through short design as well as savings in material, work, transport and storage costs
- The compact design enables the valve chamber to be made from sectional concrete giving typical savings of 25 % in chamber construction costs
- A combination of E3 Combi-T with E3 reducing valve creates a multitude of application possibilities
- Flanges sized in accordance with EN 1092-2, drilled according to EN 1092-2 | PN 10 standard; EN 1092-2 | PN 16 DN 200 please specify on order - other standards on request
- Suitable for cleaning with a cleaning pig
- One extension spindle for several dimensions
- Suitable for operation by automatic actuators
- Easy retrofitting of position indicator and automatic actuators on the standard bonnet
- Duplex stainless steel spindle

**Standard version:** without handwheel and extension spindle

**Special versions:** on request

No. 4340E3



### Suitable accessories

**Suitable accessories:** see page A 2/2

Handwheel:		No. 7800
Extension spindles:	rigid	No. 9000E2/E3
	telescopic	No. 9500E2/E3
Surface boxes:	rigid	No. 1750
	telescopic	No. 2050, No. 2051K
Valve actuator:		No. 9920
Adapter for actuator (E2/E3 adapter):		No. 8630E2/E3
Base plate:		No. 3481, No. 3482
Operating cap:		No. 2156, No. 2157, No. 2158
Extension spindle:		No. 7820, No. 7825
Position indicator:		No. 2170E2/E3
Bolts:		No. 8810, No. 8830, No. 8840
Flat gasket:		No. 3390, No. 3470
HAWAK-pillar:		No. 9894, No. 9895

Order no.	MOP (PN)	Dimensions DN	Valve   DN1				
			65	80	100	150	200
4340E3	16	80					
		100					
		125					
		150					
		200					

# E3 Combi-T

Flange T-piece with integrated E3-valve, PN 10 | PN 16

No. 4340E3

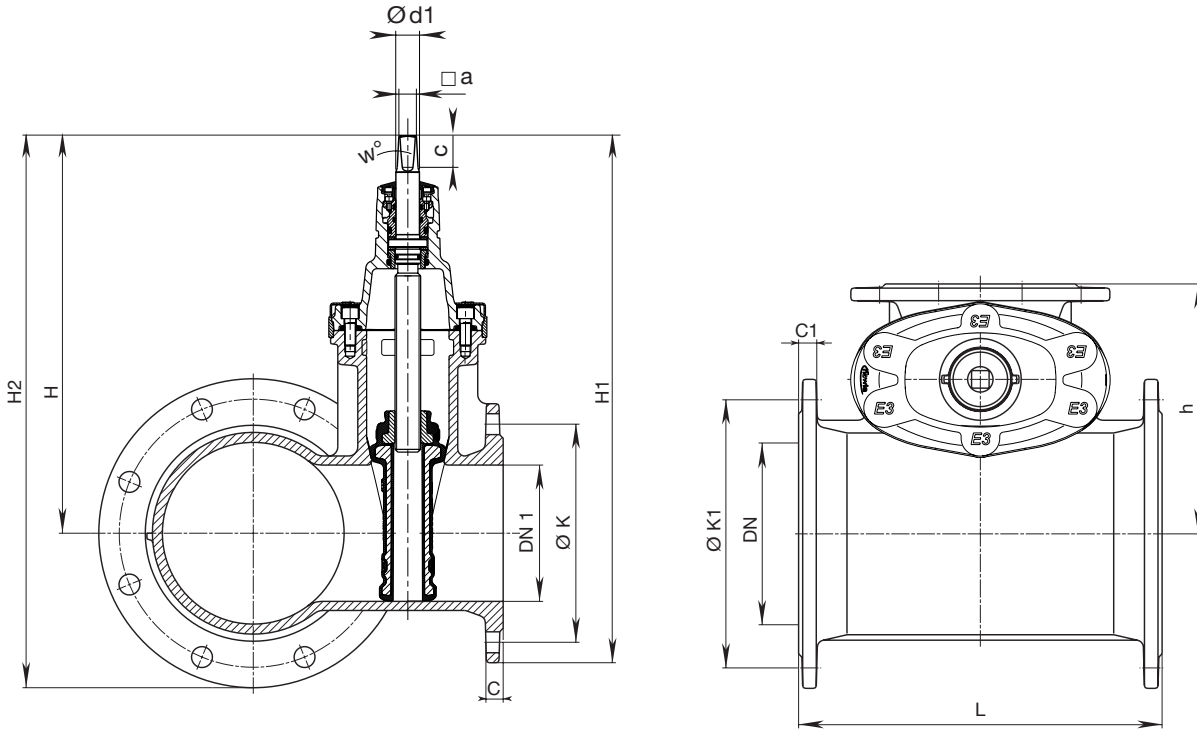

DN	DN 1 Valve	E3 Combi-T					Flange				Spindle				Weight
		L	H	H1	H2	h	ØK	C	ØK1	C1	□ a	c	w°	Ød1	
80	80	280	313	413	413	170	160	19	160	19	17,3	35	3°	24	24,0
100	65	260	305	397	408	180	145	19	180	19	17,3	35		24	29,5
100	80	280	313	413	416	200	160	19	180	19	17,3	35		24	30,0
100	100	310	343	453	453	200	180	19	180	19	19,3	38		24	34,0
125	80	280	313	413	432	200	160	19	210	19	17,3	35		24	30,5
125	100	310	343	453	469	215	180	19	210	19	19,3	38		24	36,5
150	65	260	305	397	441	210	145	19	240	19	17,3	35		24	33,0
150	80	280	313	413	444	220	160	19	240	19	17,3	35		24	36,0
150	100	310	343	453	487	220	180	19	240	19	19,3	38		24	40,5
150	150	400	433	576	576	250	240	19	240	19	19,3	38		26	55,5
200	80	280	313	413	484	250	160	19	295	20	17,3	35		24	43,0
200	100	310	343	453	521	250	180	19	295	20	19,3	38		24	49,5
200	150	400	433	576	610	275	240	19	295	20	19,3	38		26	68,5
200	200	460	541	711	711	295	295	20	295	20	24,3	48		30	90,0

# E3 Combi-III

## Flanged T-piece with 3 flanged outlets and 2 or 3 integral E3 valves, PN 10 | PN 16



### Design features

- Resilient seated gate valve combined with flange-T-piece
- Space saving installation through short design as well as savings in material, work, transport and storage costs
- The compact design enables the valve chamber to be made from sectional concrete giving typical savings of 25 % in chamber construction costs
- Vertical connection DN 100 optional
- Internal thread connection 3/4" - optional for manometer, ball valve outlet etc.
- Flanges sized in accordance with EN 1092-2, drilled according EN 1092-2 | PN 10 standard; EN 1092-2 | PN 16 DN 200 please specify on order - other standards on request
- Suitable for cleaning with a cleaning pig
- Duplex stainless steel spindle

No. 4450E3

No. 4460E3



### Suitable accessories

**Suitable accessories:** see page A 2/2

Handwheel:		No. 7800
Extension spindles:	rigid	No. 9000E2/E3
	telescopic	No. 9500E2/E3
Surface box:		No. 4550
Operating cap:		No. 2156, No. 2157, No. 2158
Extension spindle:		No. 7820, No. 7825
Position indicator:		No. 2170E2/E3
Bolts:		No. 8810, No. 8830, No. 8840
Flat gasket:		No. 3390, No. 3470
Blanking cap:		No. 8570E2/E3

Instead of a bonnet, a cap No. 8570E2/E3 can be fitted onto the body of any outlet not requiring a valve



Please specify the arrangement of the valves in a clockwise direction!

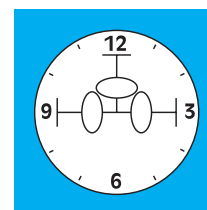

Order no.	Version	MOP (PN)	No. of valves	Dimensions/DN				
				80	100	125	150	200
4450E3	Without vertical centre outlet	16	2					
			3					
4460E3	With vertical outlet		2					
			3					

# E3 Combi-III

Flanged T-piece with 3 flanged outlets and 2 or 3 integral E3 valves, PN 10 | PN 16

No. 4450E3

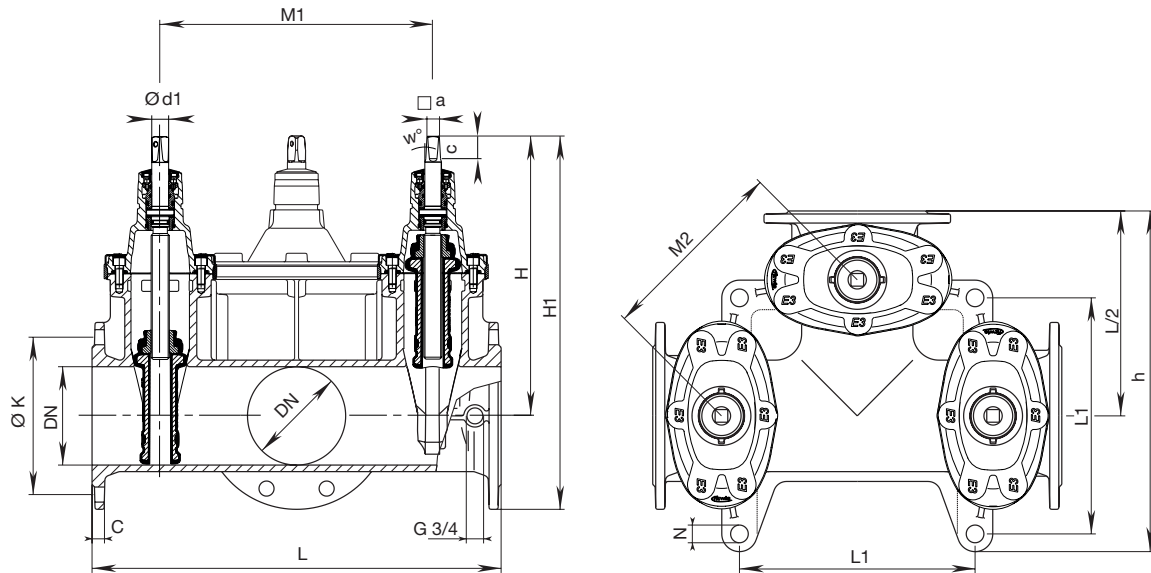

DN	E3 Combi III without vertical centre outlet										Spindle			Weight (no. of valves)		
	L	H	H 1	ØK	C	M1	M2	L1	h	N	□ a	c	w°	Ød1	2	3
80	435	313	413	160	19	255	180	-	318	-	17,3	35	3°	24	45,0	47,0
100	555	343	453	180	19	365	258	212	411	27	19,3	38		24	68,0	67,0
125	615	421	571	210	19	415	294	360	515	27	19,3	38		26	101,0	153,0
150	625	433	576	240	19	415	294	360	520	27	19,3	38		26	105,0	114,5
200	695	541	711	295	20	465	329	445	602	32	24,3	48	30	167,0	183,0	

No. 4460E3

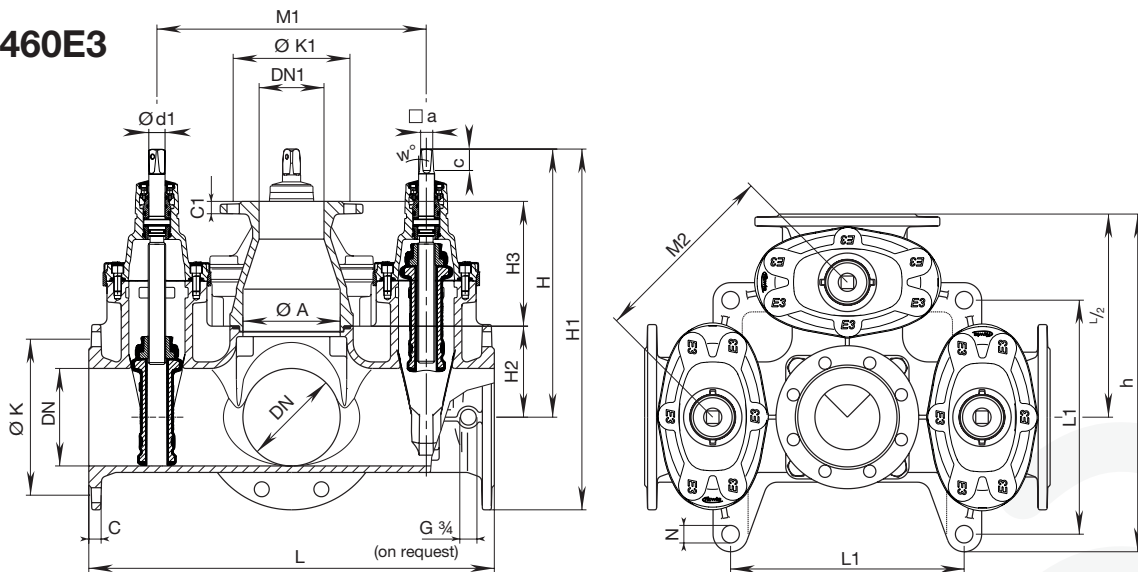

DN	E3 Combi III with vertical centre outlet													Spindle			E3 Combi III with vertical centre outlet					
	ØA	DN 1	L	L1	H	H1	H2	H3	C	C1	ØK	ØK1	M1	M2	h	N	□ a	c	w°	Ød1	2	3
100	100	100	555	212	343	453	90	+	19	+	180	+	365	258	411	27	19,3	38	3°	24	71,0	76,0
150	150	100	625	360	433	576	140	192	19	19	240	180	415	293,5	520	27	19,3	38		26	120,0	130,0
200	200	100	695	445	541	711	180	192	20	19	295	180	465	329	602	32	24,3	48		30	198,0	205,0

+ flange connection directly on the body - stud



# E3 Combi-IV



## Flanged T-piece with 4 flanged outlets and 2, 3 or 4 integral E3 valves, PN 10 | PN 16

### Design features

- Resilient seated gate valve combined with flange cross piece
- Space saving installation through short design as well as savings in material, work, transport and storage costs
- The compact design enables the valve chamber to be made from sectional concrete giving typical savings of 25 % in chamber construction costs
- Vertical connection DN 100 optional
- Internal thread connection 3/4" - optional for manometer, ball valve outlet etc.
- Flanges sized in accordance with EN 1092-2, drilled according EN 1092-2 | PN 10 standard; EN 1092-2 | PN 16 DN 200 please specify on order - other standards on request
- Suitable for cleaning with a cleaning pig
- Duplex stainless steel spindle

No. 4400E3  
No. 4410E3



Instead of a bonnet, a cap No. 8570E2/E3 can be fitted onto the body of any outlet not requiring a valve

### Suitable accessories

Suitable accessories: see page A 2/2

Handwheel:		No. 7800
Extension spindles:	rigid	No. 9000E2/E3
	telescopic	No. 9500E2/E3
Surface box:		No. 4550
Operating cap:		No. 2156, No. 2157, No. 2158
Extension spindle:		No. 7820, No. 7825
Position indicator:		No. 2170E2/E3
Bolts:		No. 8810, No. 8830, No. 8840
Flat gasket:		No. 3390, No. 3470
Blanking cap:		No. 8570E2/E3



No. 4410E3 cross connection with 3 valves and vertical centre outlet



With 3 valves and no vertical outlet

Please specify the arrangement of the valves in a clockwise direction!

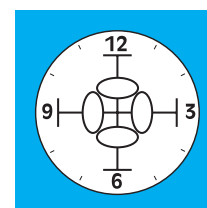

Order no.	Version	MOP (PN)	No. of valves	Dimensions/DN				
				80	100	125	150	200
4400E3	Without vertical centre outlet	16	2					
			3					
			4					
4410E3	With vertical outlet	16	3					
			4					

# E3 Combi-IV

Flanged T-piece with 4 flanged outlets and 2, 3 or 4 integral E3 valves, PN 10 | PN 16

No. 4400E3

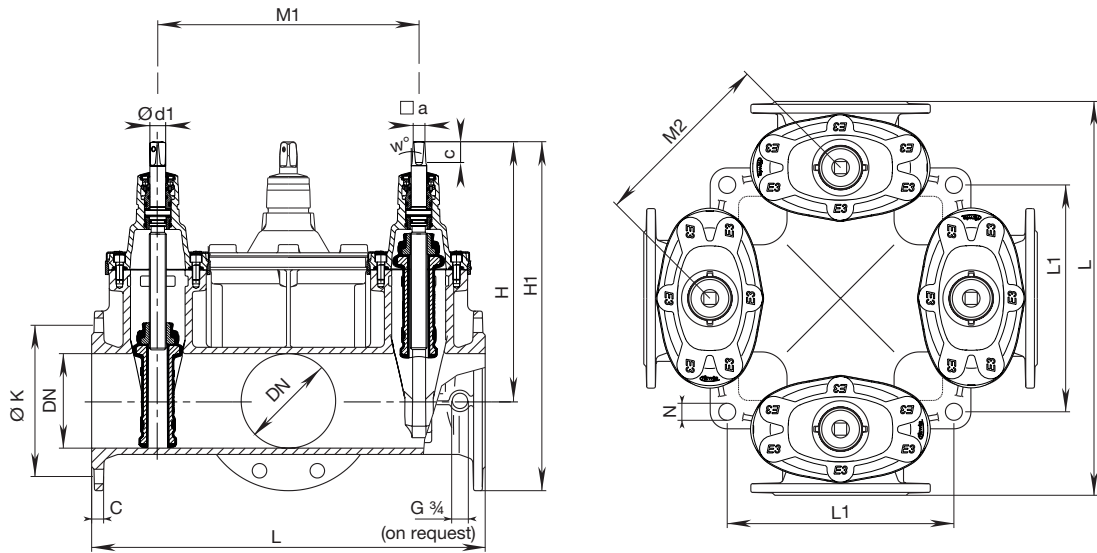

DN	E3 Combi IV without vertical centre outlet										Spindle				Weight (no. of valves)		
	L	H	H1	ØK	C	M1	M2	L1	N	□ a	c	w°	Ød1	2	3	4	
80	435	313	413	160	19	255	180			17,3	35	3°	24	55,0	60,0	65,0	
100	555	343	453	180	19	365	258	212	27	19,3	38		24	76,0	84,0	90,0	
125	615	421	571	210	19	415	293,5	360	27	19,3	38		26	125,0	135,0	139,0	
150	625	433	576	240	19	415	293,5	360	27	19,3	38		26	135,0	143,0	151,0	
200	695	541	711	295	20	465	329	445	32	24,3	48	30	207,0	223,0	238,0		

No. 4410E3

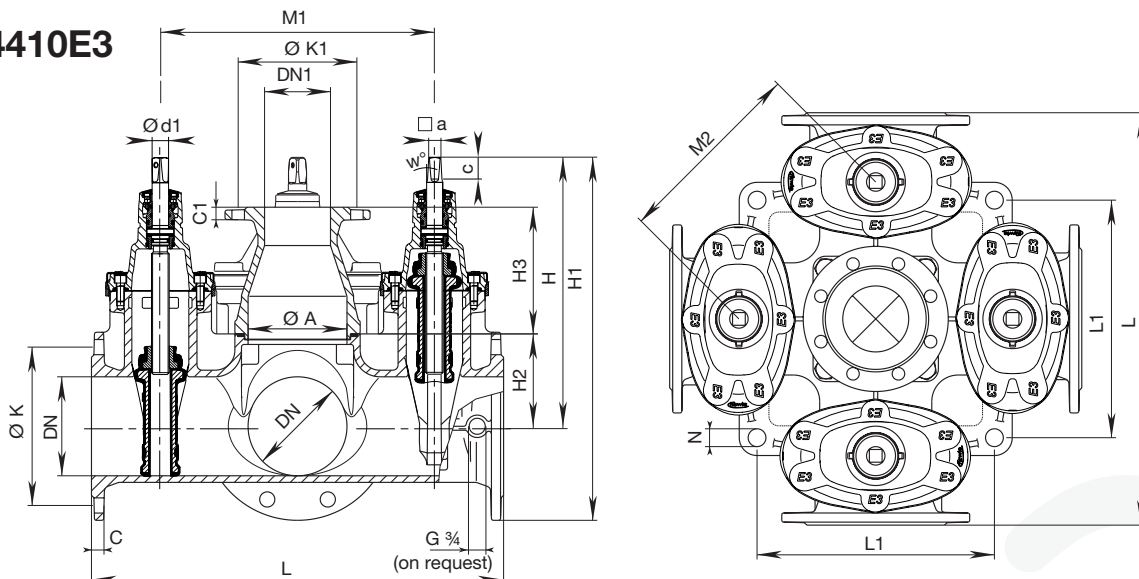

DN	E3 Combi IV with vertical centre outlet												Spindle				Weight (no. of valves)				
	ØA	DN1	L	L1	H	H1	H2	H3	C	C1	ØK	ØK1	M1	M2	N	□ a	c	w°	Ød1	3	4
100	100	100	555	212	343	453	90	+	19	+	180	+	365	258	27	19,3	38	3°	24	90,0	96,0
150	150	100	625	360	433	576	140	192	19	19	240	180	415	293,5	27	19,3	38		26	154,0	164,0
200	200	100	695	445	541	711	180	192	20	19	295	180	465	329	32	24,3	48		30		265,0

+ flange connection directly on the body - stud

# E3 Hawle-Combiflex

## DN 150, PN 10 | PN 16



### Design features

- Modular Combi-valve system enables flexible assembly arrangements
- Standardized compact construction regardless of valve configuration
- Suitable for cleaning with a cleaning pig
- Comprehensive range of interchangeable ZAK connections possible in every module
- Unique design facilitates easy, rapid exchange of any module
- Duplex stainless steel spindle

### Material | technical features

- 1 Resilient seated E3 valve according to EN 1074-1 and 1074-2
- 3 Molybdenum coated, A4 type clamping ring bolts
- 4/11 ZAK-46 (4) or ZAK-34 (11) socket for corrosion-free connection of sensors or ZAK Service valve
- 2/5/7/ 9/10 Hawle Combiflex vertical outlet (2) optionally DN 80 or DN 100 end cap (5), clamping ring (7), middle section DN 150 (9), E3 body (10) reduced in DN 80, DN 100, DN 125; or expanded to DN 200: ductile iron, epoxy powder coated
- 6 HAWLE-COMBIFLEX mounting frame: ductile iron, epoxy powder coated, with ring bolts for fastening hoists and integrated rings for floor connections
- 8 Quality inspection seal
- 12 Operating cap made of aluminum, including covering cap with direction indicator
- 13 Vertical outlet with affixed flat elastomer gasket
- 14 Outlet ET 1", optional (not installed)
- 15 Anchoring system, optional

No. 4420E3

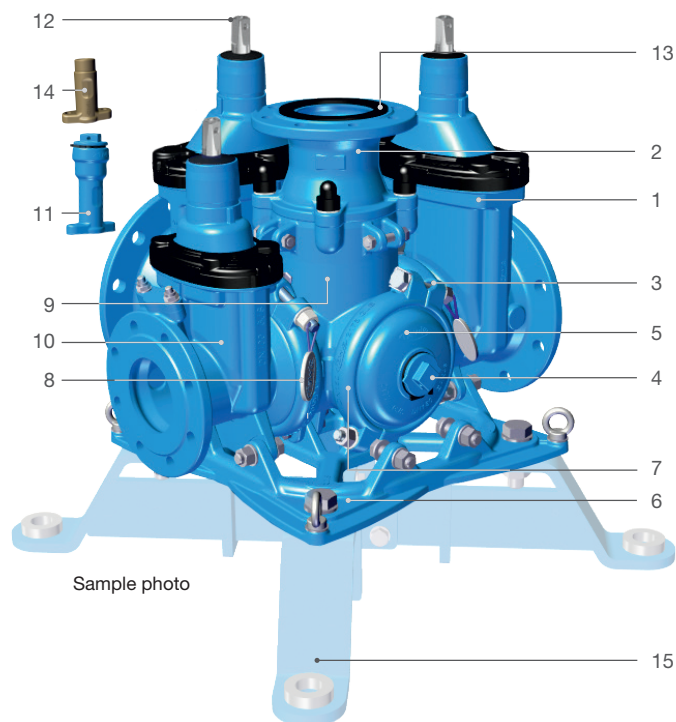

Sample photo

### Suitable accessories

**Suitable accessories:** see page A 2/2

- Handwheel: No. 7800
- Extension spindles: rigid No. 9000E2/E3  
telescopic No. 9500E2/E3
- Surface boxes: rigid No. 1750  
telescopic No. 2050, No. 2051K
- Operating cap: No. 2156, No. 2157, No. 2158
- Extension spindle: No. 7820, No. 7825
- Bolts: No. 8810, No. 8830, No. 8840
- Ground-distance sets: No. 8644
- Flat gasket: No. 3390, No. 3470
- Operating cap: No. 2157, No. 2158
- ET 1" outlet: No. 6979
- ZAK 34 outlet: No. 6979
- ZAK 34 plug: No. 6980
- Blanking cap: No. 8570E2/E3

**Individual combination options** see page A 9/3

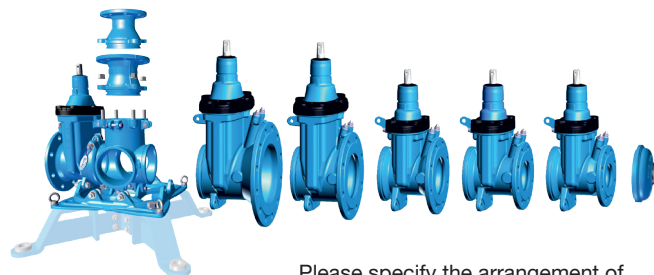

Please specify the arrangement of the valves in a clockwise direction!

Order no.	Version	MOP (PN)	Dimensions / DN	Possible reduction / DN	Possible vertical outlet / DN	Weight min. – max.
4420E3	Individually configurable	10/16	150	80	80/100	57 – 212
				100		
				125		
				150		
				200		

Flange sized and drilled in accordance with EN 1092-2 standard PN 10. Please specify PN 16 when ordering. Standard version inclusive operating caps (remove in case of actuation by extension spindle or handwheel!) Please use the HAWLE-COMBIFLEX order form. It can be found on our homepage.

# E3 Hawle-Combiflex

DN 150, PN 10 | PN 16

No. 4420E3

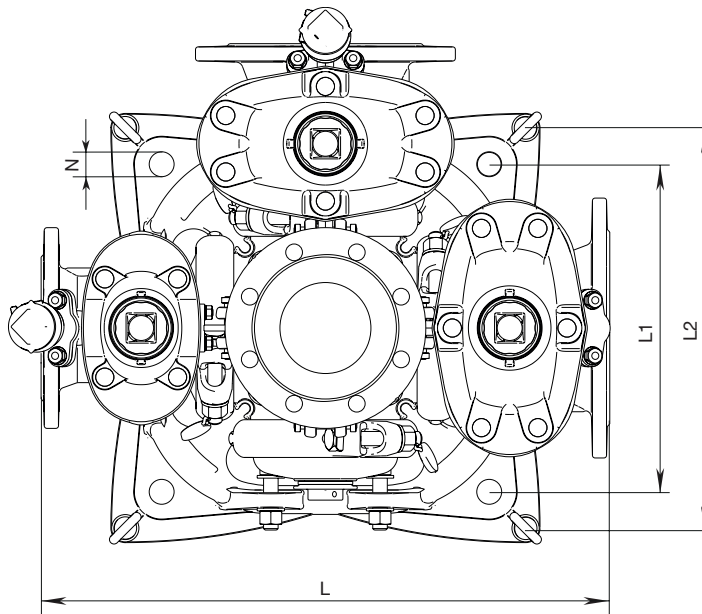
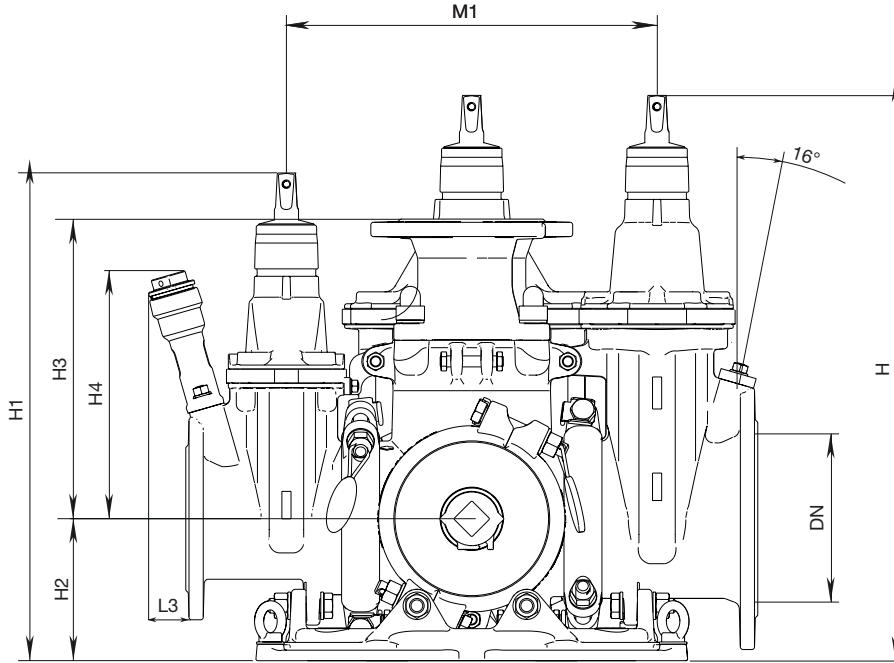

DN	E3 Hawle-Combiflex												
	MOP (PN)	DN	L*	L1	L2	L3	H	H1	H2	H3	H4	M1*	Ø N
150	10/16	80	625	360	440	37	609	518	155	328	262	405	27,4
		100				40					271		
		125				38					284		
		150				40					298		
		200*				24					335		

\*The external dimensions (L, M1) remain the same with reducing valves!

\* height compensation due to flange necessary

#Transport dimensions = L

# E3 Hawle-Combiflex

## Individual parts DN 150

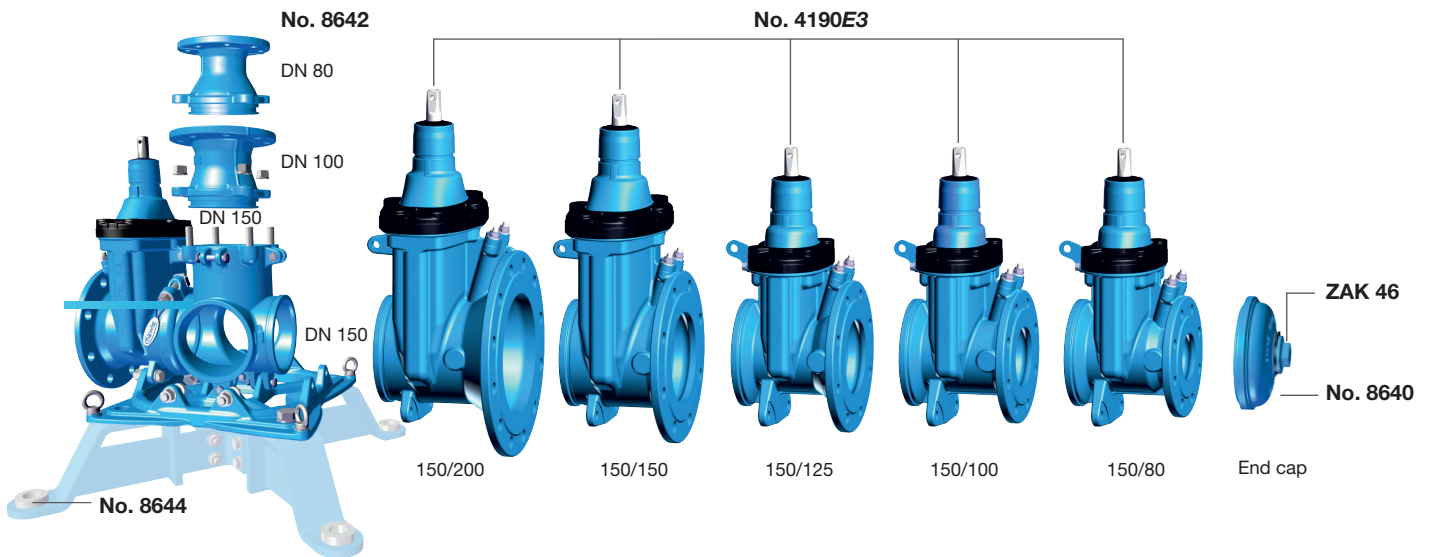

### No. 4190E3

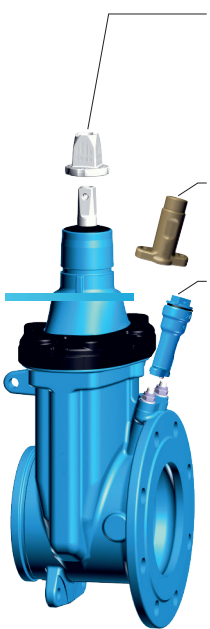

Optional  
Operating cap  
Order-No. 2156  
Order-No. 2157  
Order-No. 2158

Optional  
Outlet ET 1"  
Order-No. 6979

Optional  
ZAK 34 outlet  
Order-No. 6979  
ZAK-plug  
Order-No. 6980

- Incl. bolt fastener for the middle section
- Fits through manhole openings

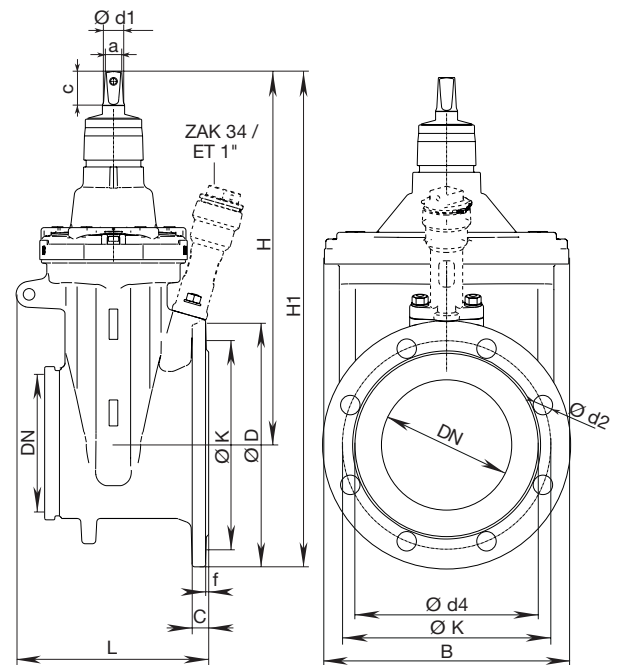
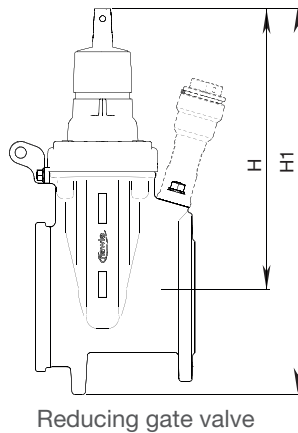

DN	Hawle-Combiflex E3 gate valve																			
	Flange						Bolts			Spindle			Valve							
	DN	MOP (PN)	Ø D*	C	Ø K	Ø d4	f	Qty.	Thread	Ø d2	a	c	Ø d1	Wedge DN	Service outlet	H	H1*	L*	B*	~ Max. weight
150	80	10 16	200	19	160	133		8	M16	19			25	100	ZAK 34 ET 1"	343	453	258	213	21,8
	100	10 16	220	19	180	153		8	M16	19			25	100		343	453	261	213	22,5
	125	10 16	250	19	210	183	3	8	M16	19	19,3	38	25	100		343	468	259	213	23,7
	150	10 16	285	19	240	209		8	M20	23			28	150		433	576	262	283	34,7
	200	10 16	340	20	295	264		8 12	M20	23			28	150		433	603	281	283	40,0

\* Transport dimensions

# E3 Hawle-Combiflex

## Individual parts DN 150

### Hawle-Combiflex end cap No. 8640

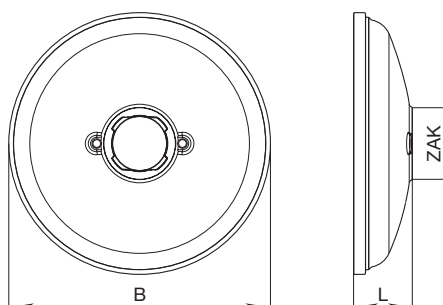

- ZAK 69 socket

DN	Hawle-Combiflex end cap			
	B	ZAK-socket	L	Weight
150	177	ZAK 46	47	2,5

### Hawle-Combiflex vertical outlet No. 8642

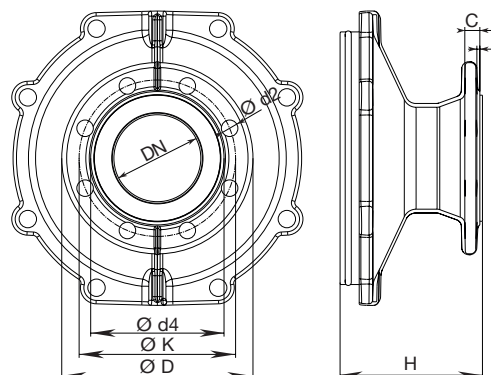

- Incl. affixed elastomer flange gasket

DN	Hawle-Combiflex vertical outlet											
	Flange							Bolts			Vertical outlet	
	DN	MOP (PN)	Ø D	C	Ø K	Ø d4	f	Qty.	Thread	Ø d2	H	Weight
150	80	10/16	200	19	160	133	3	8	M16	19	155	7,0
	100	10/16	220	19	180	153	3	8	M16	19	155	8,0

### Blanking cap No. 8570E2/E3



- For combi valves in place of valve bonnet
- Made of ductile iron, epoxy powder coated without screws and hood seal

Order No.	DN	Weight
8570E2/E3	80	1,6
	100	1,9
	125 – 150	3,2
	200	5,0

### Hawle-Combiflex ground-distance set No. 8644 (order separately)

Stainless steel

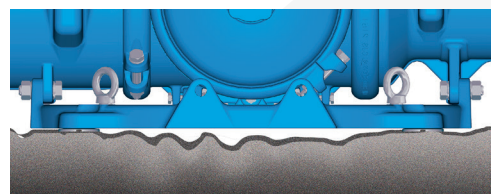
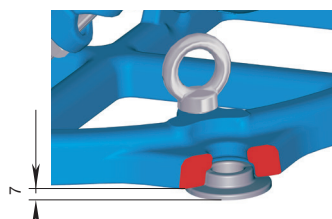
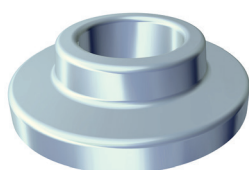

# E3 Hawle-Combiflex

## DN 250 / DN 300, PN 10 | PN 16



### Design features

- Modular Combi-valve system enables flexible assembly arrangements
- Standardized compact construction regardless of valve configuration
- Suitable for cleaning with a cleaning pig
- Comprehensive range of interchangeable ZAK connections possible in every module
- Unique design facilitates easy, rapid exchange of any module
- Duplex stainless steel spindle

No. 4420E3

### Material | technical features

- 1 Resilient seated E3 valve in DN 150 to DN 400 according to EN 1074-1 and 2
- 3 Molybdenum coated, A4 type clamping ring bolts
- 4/11 ZAK-69 (4) or ZAK-46 (11) socket for corrosion-free connection of sensors or ZAK Service valve
- 2/5/7/ Hawle-Combiflex vertical outlet (2) optionally
- 9/10 DN 100 or DN 150 end cap (5), clamping ring (7), 2 types of middle section DN 250 or DN 300 (9), E3 body (10) reduced in DN 150 and DN 200 or expanded to DN 400: ductile iron, epoxy powder coated
- 6 Hawle-Combiflex mounting frame: ductile iron, epoxy powder coated, with ring bolts for fastening hoists and integrated rings for floor connections
- 8 Quality inspection seal
- 12 Operating cap made of aluminum, including covering cap with direction indicator
- 13 Vertical outlet with affixed flat elastomer gasket
- 14 Assembly fittings kit (4 items each: plastic support liner; hot-dip galvanized spacer disk; hot-dip galvanized washer)
- 15 Anchoring system, optional

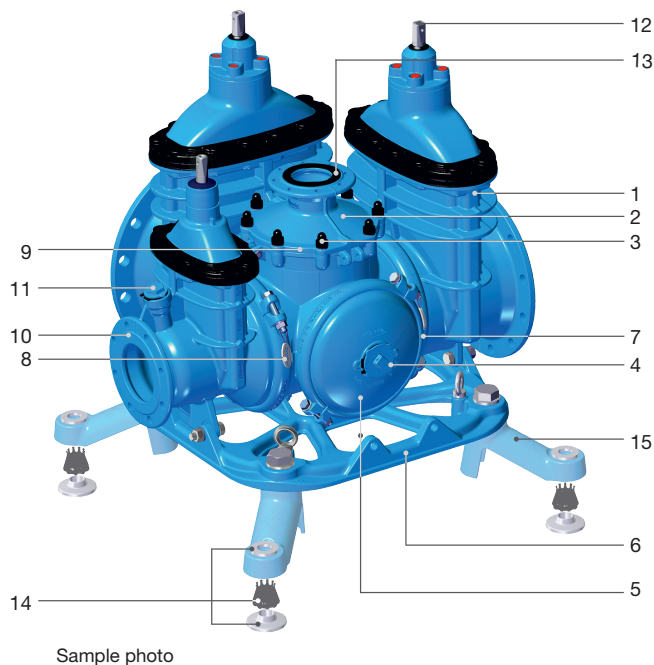

Sample photo

Individual combination options see page A 9/7



### Suitable accessories

Suitable accessories: see page A 2/2

- Handwheel: No. 7800
- Extension spindles: rigid No. 9000E2/E3  
telescopic No. 9500E2/E3
- Surface boxes: rigid No. 1750  
telescopic No. 2050, No. 2051K
- Operating cap: No. 2156, No. 2157, No. 2158
- Extension spindle: No. 7820, No. 7825
- Bolts: No. 8810, No. 8830, No. 8840
- Assembly fittings kit: No. 8647
- Flat gasket: No. 3390, No. 3470
- Blanking cap: No. 8570E2/E3

Order no.	Version	MOP (PN)	Dimensions / DN	Possible reduction / DN	Possible vertical outlet / DN	Weight min. - max.	
4420E3	Individually configurable	10	250	150	100	265 – 465	
				200			
		16	250	150	150		
				200			
		10	300	16	150	100	330 – 706
					200		
					250		
					300		
400							

Flange sized and drilled in accordance with EN 1092-2 standard PN 10. Please specify PN 16 when ordering. Standard version including operating cap (to be removed during operation using extension spindle or hand wheel!) Please use the HAWLE-COMBIFLEX order form. It can be found on our homepage.

# E3 Hawle-Combiflex

DN 250 / DN 300, PN 10 | PN 16

No. 4420E3

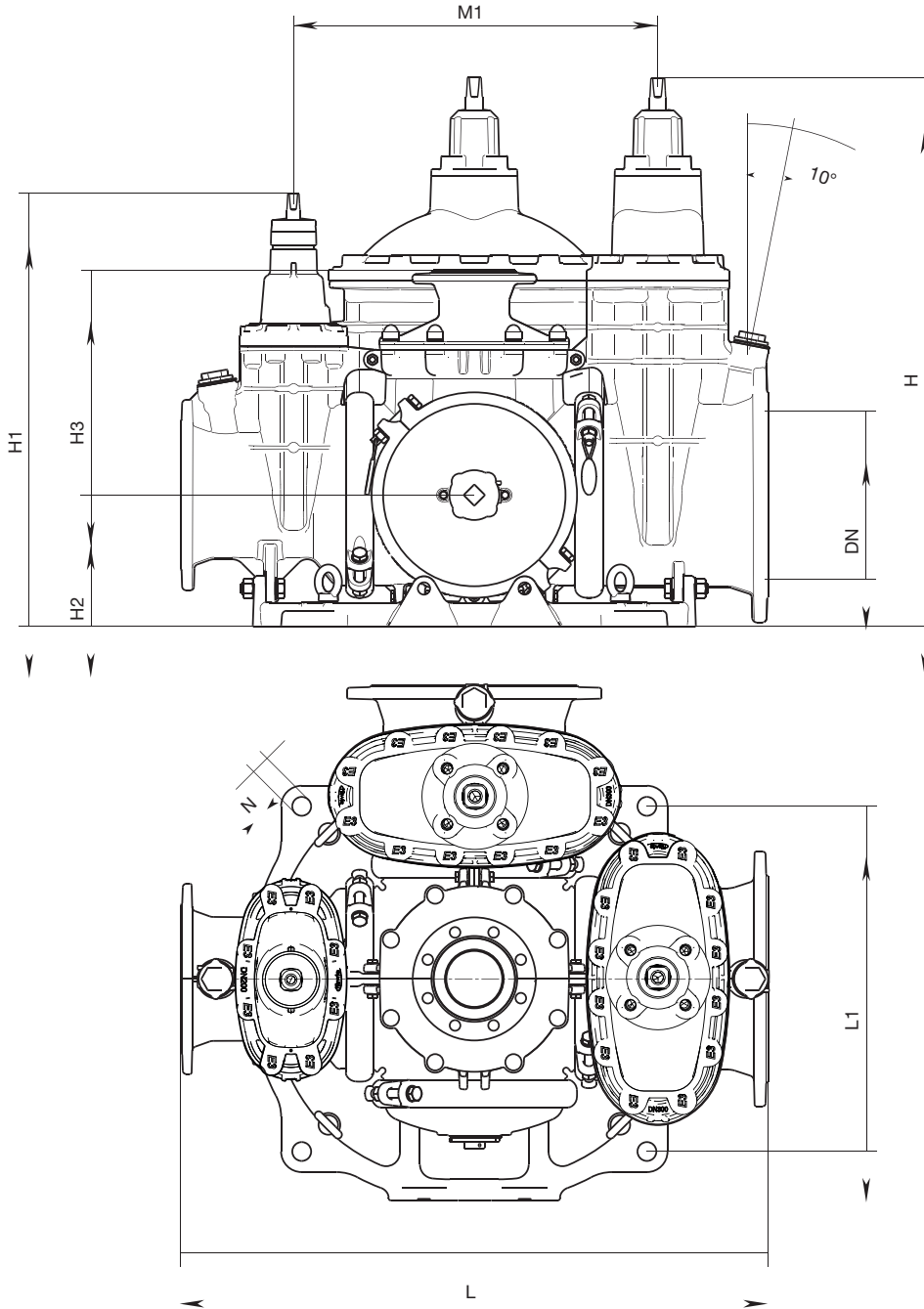

DN	Hawle-Combiflex									
	MOP (PN)	L*	L1	H	H1	H2	H3	DN	M1*	ØN
250	10	960	617	911	755	210	359	150	590	34
	16							200		
								250		
300	10	1050	617	1021	809	235	399	150	646	34
								200		
								250		
								300		
	16							400		

\*The external dimensions (L, M1) remain the same with reducing valves!



# E3 Hawle-Combiflex

## Individual parts DN 250 / DN 300

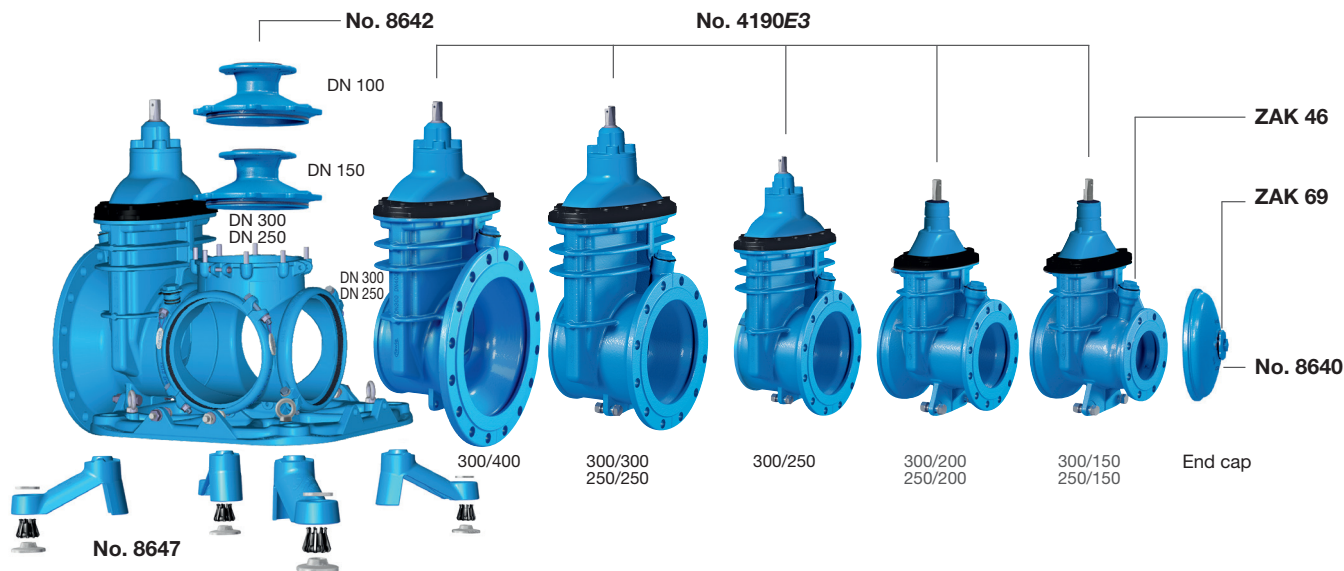

### Hawle-Combiflex E3 gate valve No. 4190E3

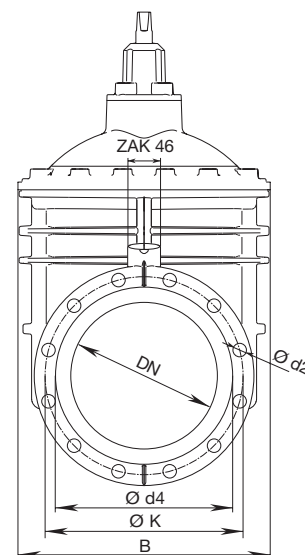
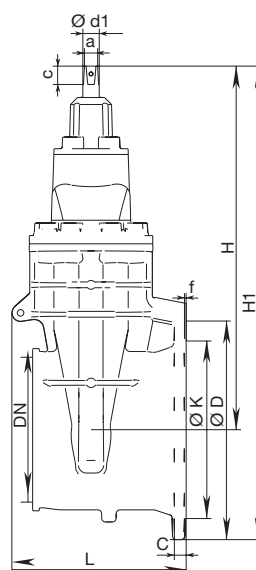
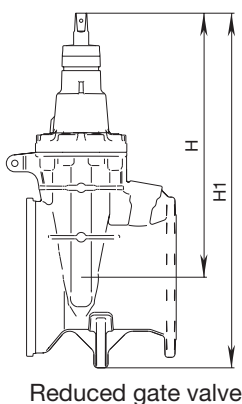

Hawle-Combiflex E3 gate valve																		
DN	Flange					Bolts			Spindle			Valve						
	DN	MOP (PN)	ØD	C	ØK	Qty.	Thread	Ød2	a	c	Ød1	Wedge DN	Service outlet	H	H1*	L*	B*	Weight
250	150	10 16	285	19	240	8	M20	23	24,3	48	32	200	ZAK 46	541	707	337	356	61,0
	200	10 16	340	20	295	8 12	M20	23	24,3	48	32	200		541	710	337	356	62,0
	250	10 16	400	22	350 355	12	M20 M24	23 28	27,3	48	34	250		649	850	337	438	89,0
300	150	10 16	285	19	240	8	M20	23	24,3	48	32	200		541	734	361	356	65,0
	200	10 16	340	20	295	8 12	M20	23	24,3	48	32	200		541	734	361	356	66,0
	250	10 16	400	22	350 355	12	M20 M24	23 28	27,3	48	34	250		649	850	361	438	93,0
	300	10 16	455	24,5	400 410	12	M20 M24	23 28	27,3	48	34	300	731	960	361	523	132,0	
400*	10 16	580	28	515 525	16	M24 M27	28 31	27,3	48	34	300	731	1030	361	523	146,0		

\* Transport dimensions

\*height adjustment necessary due to flange sheet

# Notes



# E3 Hawle-Combiflex

Individual parts DN 250 / DN 300



## Hawle-Combiflex end cap No. 8640



- ZAK 69 socket

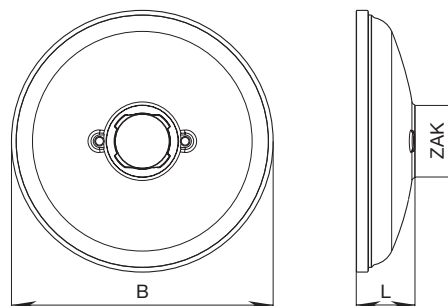

DN	Hawle-Combiflex end cap			
	B	ZAK-socket	L	Weight
250	284	ZAK 69	67	6,0
300	335	ZAK 69	77	7,5

## Hawle-Combiflex vertical outlet No. 8642



- Incl. affixed elastomer flange gasket

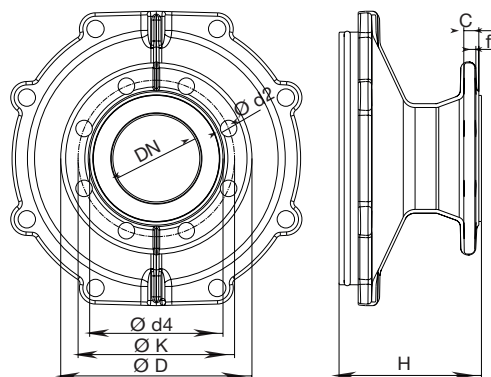

DN	Hawle-Combiflex vertical outlet											
	Flange						Bolts			Vertical outlet		
	DN MOP (PN)	Ø D	C	Ø K	Ø d4	f	Qty.	Thread	Ø d2	H	Weight	
250	100	10/16	220	19	180	153	3	8	M16	19	146	12,0
	150	10/16	285	19	240	209	3	8	M20	23	146	11,0
300	100	10/16	220	19	180	153	3	8	M16	19	160	13,0
	150	10/16	285	19	240	209	3	8	M20	23	160	13,0

## Blanking cap No. 8570E2/E3



DN 150 – 200

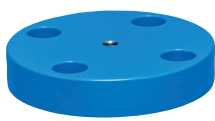

DN 250 – 300

Order No.	DN	Weight
8570E2/E3	150	3,2
	200	5,0
	250 – 300	5,0

- For combi valves in place of valve bonnet
- Made of ductile iron, epoxy powder coated without screws and hood seal

# Notes



# Hawle-E1+ gate valve

## Overview



### Design features

- Resilient seated gate valve according to EN 1074-1 and EN 1074-2 with smooth, straight bore
- Flanged valve, short face-to-face dimension
- Wedge guide with high glide characteristics; load-optimised design guarantees very low wear and closing torques
- Wedge nut resists high torque load due to its larger size with more than the required thread length
- Spindle bearing attached in bonnet by bayonet connection
- O-rings on all sides mounted in corrosion-proof material
- Friction washers guarantee smooth spindle guiding
- Suitable for underground installation
- Duplex stainless steel spindle

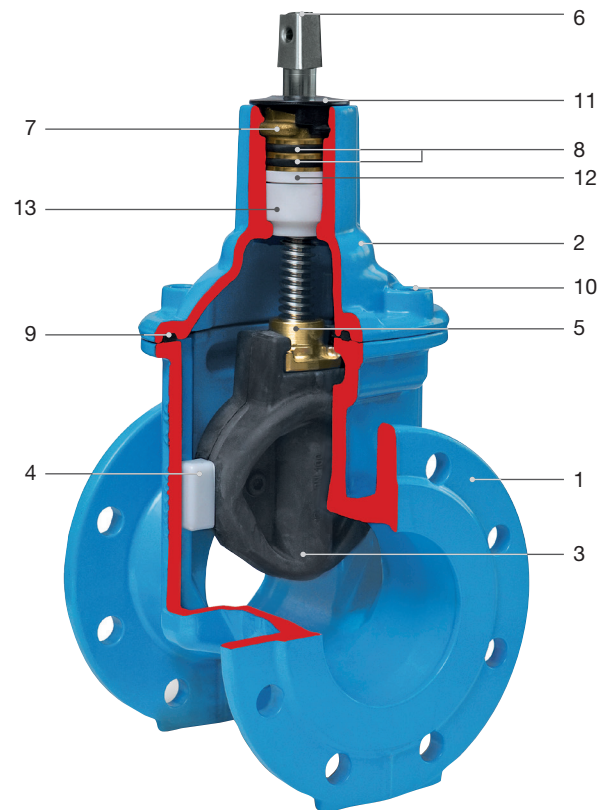

### Material | Technical features

- 1,2 Body (1), bonnet (2) made of ductile iron, epoxy powder coated inside and out (see page 4)
- 3 Wedge made of ductile iron, fully rubberized with vulcanized elastomer inside and out
- 4 Wedge guide made of wear-resistant POM
- 5 Wedge nut made of brass
- 6 Duplex stainless steel spindle with rolled thread and polished O-ring slide faces, bearing made of POM
- 7 O-ring bush made of brass, attached in bonnet by bayonet connection, anti-rotation, multiple O-ring sealing
- 8 O-rings made of elastomer
- 9 Bonnet gasket made of elastomer
- 10 Allen screws corrosion protected by being encased into the body with an enclosing gasket and wax
- 11 Covering cap as dirt protection of the spindle bearing made of PE
- 12 Friction washer made of POM
- 13 Spindle bearing made of POM

# Notes



# Hawle-E1+ gate valve

## With flange DN 50 – 300, PN 10 | PN 16



### Design features

- Resilient seated gate valve with smooth, straight bore
- Flanges sized in accordance with EN 1092-2, drilled according to EN 1092-2 | PN 10 standard; EN 1092-2 | PN 16 for DN 200 Please specify on order - other standards on request
- Suitable for cleaning with a cleaning pig
- Short face-to-face length (EN 558 GR 14)
- Long face-to-face length (EN 558 GR 15)

**No. 4000E1+**  
**No. 4700E1+**

**Standard version:** without handwheel and extension spindle (only suitable for manual actuation)

**Special versions:** on request

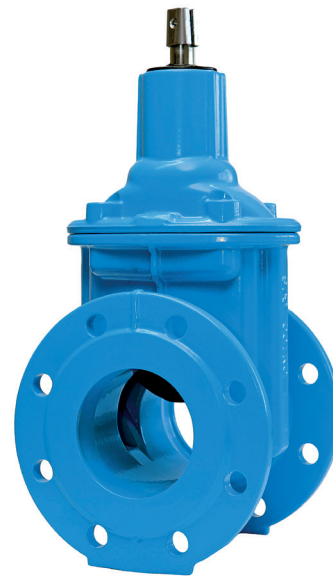

### Suitable accessories

**Suitable accessories:** see page A 2/2

Handwheel:		No. 7800
Extension spindles:	rigid	No. 9000
	from DN 65	No. 9000A
	telescopic	No. 9500
	from DN 65	No. 9500A
Surface boxes:		No. 9500
	rigid	No. 1750
	telescopic	No. 2050
		No. 2051K
Base plate:		No. 3480, No. 3481
Operating cap:		No. 2156, No. 2157, No. 2158
Spindle extension:		No. 7820, No. 7825
Bolts:		No. 8810, No. 8830, No. 8840
HAWAK-pillar:		No. 9894
Flat gasket:		No. 3390, No. 3470

### Application example



Order no.	Version	MOP (PN)	Dimensions/DN									
			50	65	80	100	125	150	200	250	300	
4000E1+	short EN 558-1 GR 14	10										
		16										
4700E1+	long EN 558-1 GR 15	10										
		16										

# Hawle-E1+ gate valve

With flange DN 50 – 300, PN 10 | PN 16

No. 4000E1+

No. 4700E1+

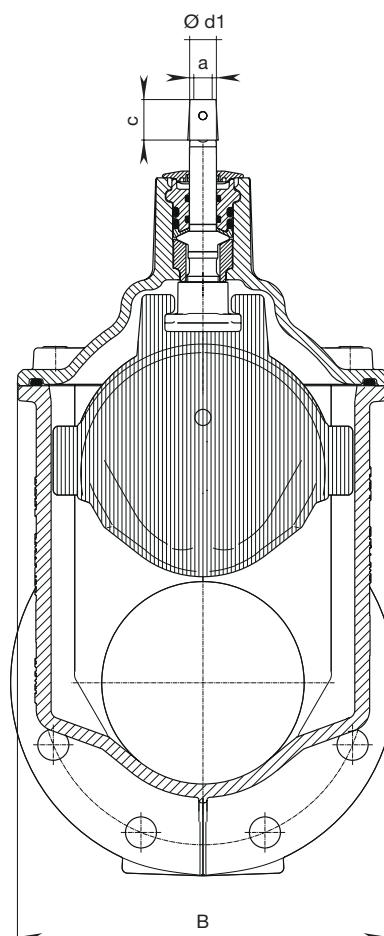
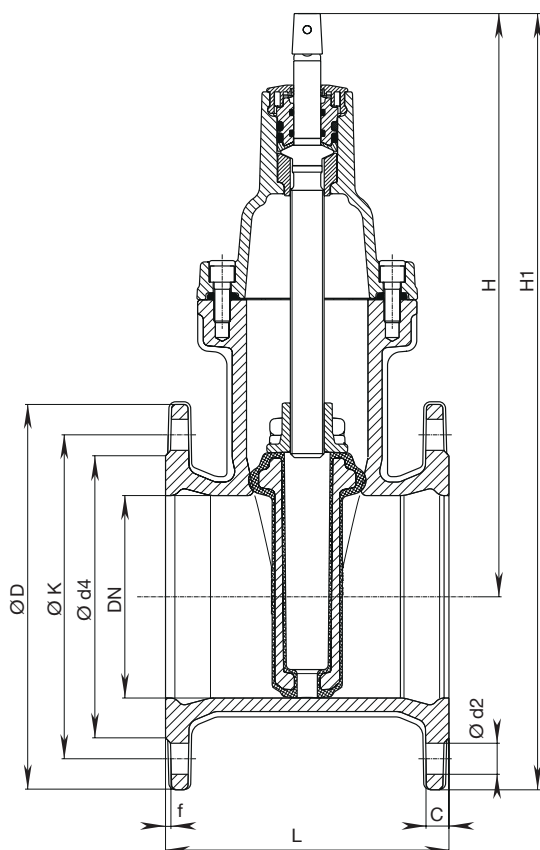

DN	MOP (PN)	Flange					Bolts			Spindle			Valve				Weight		
		$\varnothing D$	C	$\varnothing K$	$\varnothing d4$	f	Qty	Thread	$\varnothing d2$	a	c	$\varnothing d1$	H	H1	L		B	short	long
50	10	165	18	125	98	5	4	M 16	19	14,8	30	18	230	313	150	250	135	8,8	10,7
	16																		
65	10	185	18	145	118	5	4	M 16	19	17,3	30	20	298	390	170	270	172	13,5	16,9
	16																		
80	10	200	18	160	133	5	8	M 16	19	17,3	30	20	305	405	180	280	172	14,5	19,0
	16																		
100	10	220	18	180	153	5	8	M 16	19	19,3	30	20	339	449	190	300	203	18,5	25,2
	16																		
125	10	250	17	210	183	4	8	M 16	19	19,3	30	20	420	545	200	325	275	30,5	36,7
	16																		
150	10	285	17	240	209	4	8	M 20	23	19,3	30	20	432	575	210	350	275	34,0	42,9
	16																		
200	10	340	19,5	295	264	4,5	8	M 20	23	24,3	38	25	534	704	230	400	345	54,6	68,0
	16																	12	M 24
250	10	400	21,5	350	318	4,5	12	M 20	23	27,3	38	32	626	826	250	450	422	125,0	142,4
	16																	12	M 24



# E2 Gate Valve

## Overview

### Design features

- Resilient seated gate valve according to EN 1171, EN 1074-1 and EN 1074-2 with smooth straight-through bore
- Flange valve
- Wedge guide with high glide characteristics; load-optimised design guarantees lowest wear and minimum closing torques
- Wedge nut allows high torque load through large dimensioning of the required thread length
- O-rings, lip seals mounted in rust-proof material on all sides, can be replaced in depressurised state
- Edge protection protects during transport and storage
- Roller bearings guarantee low friction mounting of the spindle
- 100% suitable for underground installation

### Material | Technical features

- 1, 2, Body (1), bonnet (2), centering flange (16)
- 16 made of ductile iron, epoxy powder coated inside and out (see page 5)
- 3 Wedge made of ductile iron, inside and out with vulcanized elastomer
- 4 Wedge guide made of wear-resistant plastic
- 5 Wedge nut made of dezincification-resistant brass
- 6 Duplex stainless steel spindle with rolled thread and flat-rolled sealed sliding surface
- 7 O-ring bush made of brass
- 8 O-rings, lip seals made of elastomer
- 9 Back seal made of elastomer
- 10 Wiper ring made of elastomer
- 11 Bonnet gasket made of elastomer
- 12 Allen screws encased into the body with an enclosing gasket and wax, ensuring full corrosion protection
- 13 Edge protection made of PE
- 14 Ball bearing permanently lubricated
- 15 Centering ring made of POM
- 17 Centering flange gasket made of elastomer

### DN 450 – 600 Spindle bearing on ball bearing

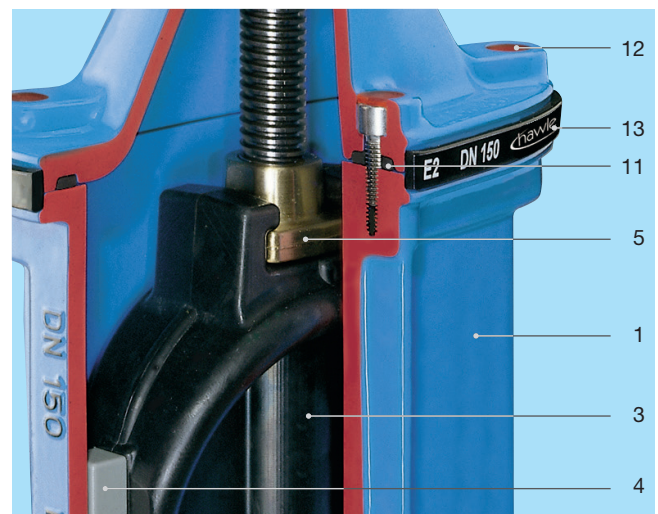
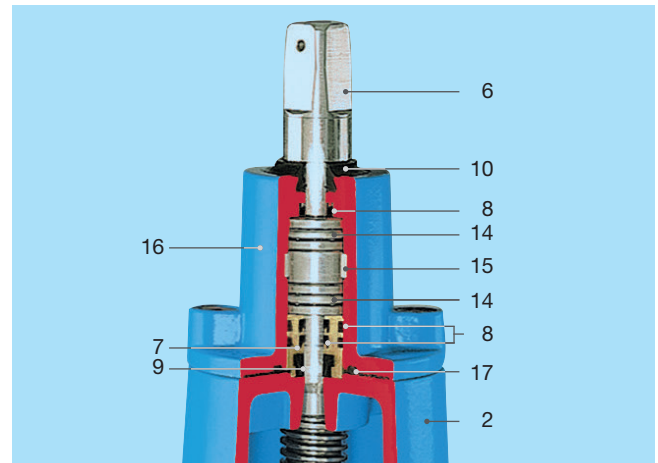

# E2 Gate valve

## With flange DN 450 – 600, PN 10 | PN 16

### Accessories

Handwheels	Page M 4/1
Extension spindles	Page M 2/1
Surface boxes	Page M 3/1
Base plate	Page M 3/7
Adapter and coupling socket	Page M 4/3
Operating cap	Page M 4/1
Spindle extension	Page M 4/1
Actuator	Page M 4/3
Position indicator	Page M 4/2
Bolts	Page M 4/4
HAWAK-pillar	Page M 5/1
Flat gaskets	Page M 7/1
Blanking cap	Page M 4/1
Flanges	Page C 4/1
Dismantling pieces	Page D 6/1

### Spare parts

Valve bonnet	Page P 2/1
Valve wedge	Page P 2/1
Valve bonnet flat gasket	Page P 2/2

### Tools

Operating key	Page Q 4/2
---------------	------------

### Technical information

Tightening torques for flange assembly	Page R 3/1
Pressure loss diagram	Page R 4/1
Spindle rotations per stroke	Page R 1/2

### Application examples



# E2 Gate valve

With flange DN 450 – 600, PN 10 | PN 16



## Design features

- Resilient seated gate valve with smooth straight-through bore
- Flanges sized in accordance with EN 1092-2, drilled according to  
EN 1092-2 | PN 10 standard 4000E2, 4700E2;  
EN 1092-2 | PN 16 4000E2, 4700E2

Please specify on order - other standards on request

- Suitable for cleaning with a cleaning pig
- Suitable for operation by automatic actuators
- O-rings replaceable without pressure
- Ball bearings in the spindle seating minimizes closing forces
- Easy to actuate without bypass and without power boost - even for 16 bar differential pressure
- For the assembling of a position indicator it is necessary to remove the centering flange and mount the adapter for position indicator

Standard version: without handwheel and extension spindle

Design versions: for actuator: No. 4000ELE2  
with position indicator: No. 4000STE2  
for seawater: No. 4002E2,  
No. 4702E2

Special versions: on request

- Bevel gearing
- for DN 500/DN 600 - version with bypass (DN 50) available
- Ventilation and exhausting;  
small amounts of air in the bonnet

No. 4000E2

No. 4700E2



Order no.	Version	MOP (PN)	Dimensions/DN			
			450*	500*	500	600
4000E2	short	16				
	EN 558 GR 14					
4700E2	long	16				
	EN 558 GR 15					

\* Body: DN 400 - flange connection: DN 450 or 500

**Suitable accessories:** see page A 11/2

Handwheel: No. 7800  
 Extension spindles: rigid No. 9000E2  
 telescopic No. 9500E2  
 Surface boxes: rigid No. 1750  
 telescopic No. 2050  
 No. 2051K  
 No. 9920  
 Valve actuator: No. 9920  
 Adapter for actuator (E2 adapter): No. 8630E2  
 Base plate: No. 3481, No. 3482  
 Operating cap: No. 2156, No. 2157, No. 2158  
 Extension spindle: No. 7820, No. 7825  
 Bolts: No. 8810, No. 8830, No. 8840  
 HAWAK-pillar: No. 9894, No. 9895  
 Flat gasket: No. 3390, No. 3470

# E2 Gate valve

With flange DN 450 – 600, PN 10 | PN 16

No. 4000E2

No. 4700E2

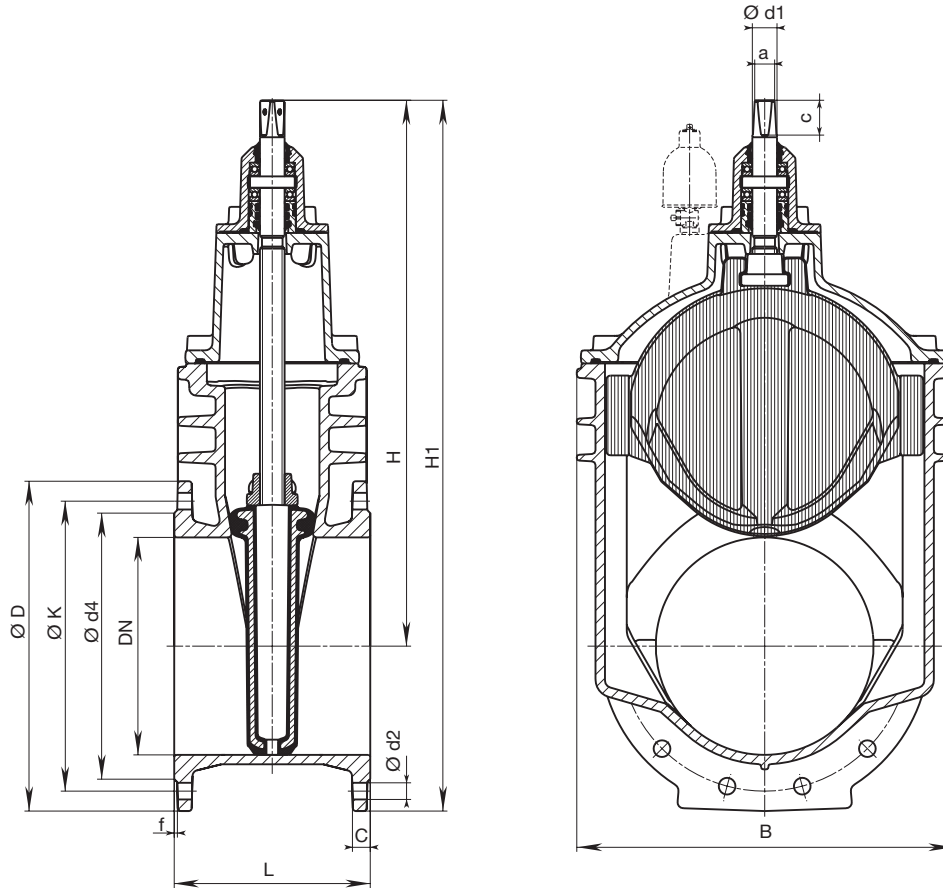

DN	MOP (PN)	Flange					Bolts			Spindle			Valve				Weight		
		Ø D	C	Ø K	Ø d4	f	Qty.	Thread	Ø d2	a	c	Ø d1	H	H1	L short	L long	B	short	long
450*	10	640	30	565	530	4	20	M 24	28	32,3	55	44	974	1310		650	687		332,0
	585			M 27				31											
500*	10	715	31,5	620	582	4	20	M 24	28	32,3	55	44	974	1345		700	687		371,0
	650			M 30				34											
500	10	715	31,5	620	582	4	20	M 24	28	36,3	66	50	1220	1578	350	700	800	488,0	542,0
	650			M 30				34											
600	10	840	36	725	720	5	20	M 27	31	36,3	66	50	1377	1797	390	800	944	720,0	789,0
	770			M 33				37											

\* Body: DN 400 - flange connection: DN 450 or 500