



AVK GATE VALVE, FLANGED, PN10/16

02/75-005

EN 558-2 S.15/DIN F5, with replaceable stem sealing, stem cap and dust caps, CTC

AVK gate valves are designed with built-in safety in every detail. The wedge is fully vulcanized with AVK's own drinking water approved EPDM rubber compound. It features an outstanding durability due to the ability of the rubber to regain its original shape, the double bonding vulcanization process and the sturdy wedge design. The triple safety stem sealing system, the high strength stem and the thorough corrosion protection safeguard the unmatched reliability.

Product description:

Flanged gate valve EN 558-2 S.15/DIN F5, with replaceable stem sealing. For drinking water and neutral liquids to max. 70°C

Standards:

- Designed according to EN 1074 part 1 & 2, Designed according to EN 1171
- Face-to-face dimension according to EN 558 Table 2 Basic Series 15
- Standard flange drilling to EN1092-2 (ISO 7005-2), PN 10/16

Test/Approvals:

- Hydraulic test according to EN 1074-1 and 2 / EN 12266
- Seat: 1.1 x PN (in bar), Body: 1.5 x PN (in bar). Operation torque test
- Approved according to ACS-France
- Approved according to CSTB NF 197

Features:

- Fixed, integral wedge nut prevents vibration and ensures durability
- Wedge fully vulcanized with drinking water approved EPDM rubber and equipped with wedge shoes to provide smooth operation
- Large conical stem hole in the wedge prevents stagnant water
- Wedge and body guide rails ensure stable operation
- Stainless steel stem with wedge stop and rolled threads for high strength
- Full circle thrust collar provides fixation of the stem and low free running torques
- Triple safety stem sealing with an NBR wiper ring and four NBR O-rings in a stem seal nut of dezincification resistant brass replaceable under pressure. A rubber manchette is the main seal to the flow
- Round bonnet gasket fixed in a recess
- Countersunk and sealed stainless steel bonnet bolts encircled by the bonnet gasket
- Full bore
- Low operating torque
- Fusion bonded epoxy coating in compliance with DIN 3476 part 1 and EN 14901, GSK approved

Accessories:

Handwheel, extension spindle, street cover, flange adaptor and combi-flange



Expect ... **AVR**

The designs, materials and specifications shown are subject to change without notice due to the continuous development of our product range.

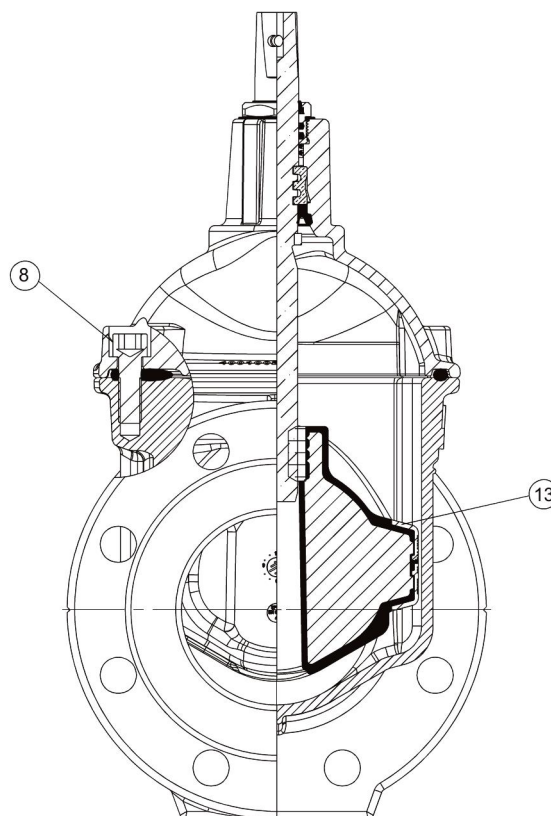
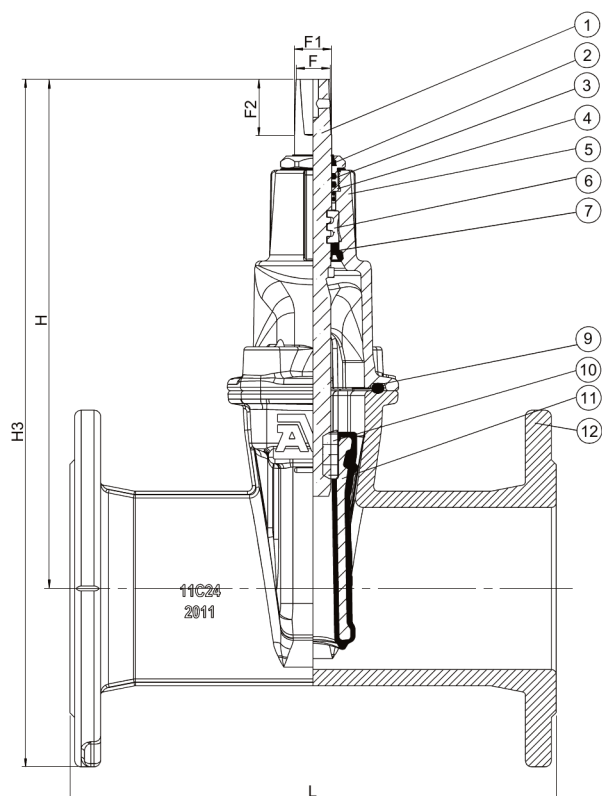

Component list:

1. Stem	Stainless steel 1.4104 (430F)	8. Bonnet bolt	Stainless steel A2, sealed with melt
2. Wiper ring	NBR rubber	9. Bonnet gasket	EPDM rubber
3. O-ring	NBR rubber	10. Wedge nut	Brass, DZR CW626N
4. Stem seal nut	Brass, DZR CW602N	11. Wedge	Ductile iron, EPDM encapsulated
5. Bonnet	Ductile iron GJS-500-7 (GGG-50)	12. Body	Ductile iron GJS-500-7 (GGG-50)
6. Thrust collar	Brass, DZR CW602N	13. Wedge shoe	Polyamide
7. Manchette	EPDM rubber		

Components may be substituted with equivalent or higher class materials without prior notification.

Reference nos. and dimensions:

AVK ref. no.	DN	Flange	L	H	H3	F	F1	F2	Theoretical weight/kg
	mm	drilling	mm	mm	mm	mm	mm	mm	
02-040-75-614649003	40	PN10/16	240	204	278	14	16	30	8.2
02-050-75-614649003	50	PN10/16	250	218	297	14	16	30	9.0
02-065-75-614649003	60/65	PN10/16	270	252	344	17	20	34	12
02-080-75-614649003	80	PN10/16	280	291	382	17	20	34	16
02-080-75-634649003 ⁽¹⁾	80	DIN1882	280	291	382	17	20	34	16
02-100-75-614649003	100	PN10/16	300	314	415	19	22	34	19
02-125-75-614649003	125	PN10/16	325	355	480	19	22	34	24
02-150-75-614649003	150	PN10/16	350	409	551	19	22	34	34
02-200-75-604649003	200	PN10	400	498	660	24	28	34	54
02-200-75-614649003	200	PN16	400	498	660	24	28	34	54
02-250-75-604649003	250	PN10	450	625	820	27	31	47	88
02-250-75-614649003	250	PN16	450	625	820	27	31	47	88
02-300-75-604647003	300	PN10	500	740	945	27	31	47	127
02-300-75-614647003	300	PN16	500	740	945	27	31	47	127
02-350-75-604640003 ⁽²⁾	350	PN10	550	935	1200	32	37	55	320
02-350-75-614640003 ⁽²⁾	350	PN16	550	935	1200	32	37	55	320
02-400-75-60464	400	PN10	600	947	1228	32	37	55	342
02-400-75-61464	400	PN16	600	947	1228	32	37	55	342

The designs, materials and specifications shown are subject to change without notice due to the continuous development of our product range.

AVK GATE VALVE, FLANGED, PN10/16**02/75-005****EN 558-2 S.15/DIN F5, with replaceable stem sealing, stem cap and dust caps, CTC****Reference nos. and dimensions:**

AVK ref. no.	DN	Flange	L	H	H3	F	F1	F2	Theoretical
	mm	drilling	mm	mm	mm	mm	mm	mm	weight/kg
02-450-75-60464 ⁽³⁾	450	PN10	650	946	1271	32	37	55	360
02-450-75-61464 ⁽³⁾	450	PN16	650	946	1271	32	37	55	360
02-500-75-60464 ⁽³⁾	500	PN10	700	946	1309	32	37	55	417
02-500-75-61464 ⁽³⁾	500	PN16	700	946	1309	32	37	55	417

(1) DN80 with 4 hole as per DIN 1882
(2) Increased bore (400 mm)
(3) Valve having a reduced bore (400 mm), Not NF approved



TECHNICAL INFORMATION - RUBBER

AVK GATE VALVES

RUBBER SPECIFICATIONS:

Rubber quality	EUW-60	EUW-70	EUW-75	EUW-80	EUW-85	EDK-70
Rubber type	EPDM	EPDM	EPDM	EPDM	EPDM	EPDM
Hardness (ShA)	60	70	76	80	85	70
Tensile strength (Mpa)	12.0	14.0	15.0	13.0	14.0	13.0
Elongation at break (%)	560	370	353	350	230	300
Density (g/cm ³)	1.07	1.10	1.18	1.21	1.21	1.12
Temperature range in dry atmospheric air:						
Minimum temperature (°C *)	-40	-40	-40	-40	-40	-40
Maximum temperature (°C *)	+120	+120	+120	+120	+120	+120
Compression set DIN 53517, 24 hours /70°C (%)	14.0	15.0	12.0	15.0	11.0	8.0
Characteristics:						
Wear resistance	3	3	3	3	3	3
Tear resistance	4	4	4	4	4	3
Resistance to weather and ozone	4	4	4	4	4	4
Resistance to hydrolysis (water and steam)	4	4	4	4	4	4
Resistance to chemicals (acids/bases)	3	3	3	3	3	3
Resistance to mineral oil and gas	0	0	0	0	0	0
Permeability	1	1	1	1	1	1

0: Low 1: Limited 2: Medium 3: Considerable 4: High

Rubber quality	NGW-55	NGW-70	NGW-90	SAK-70
Rubber type	NBR	NBR	NBR	SBR
Hardness (ShA)	4	70	90	70
Tensile strength (Mpa)	12.0	15.0	19.0	15.0
Elongation at break (%)	500	320	130	300
Density (g/cm ³)	1.17	1.23	1.31	1.17
Temperature range in dry atmospheric air:				
Minimum temperature (°C *)	-40	-40	-40	-50
Maximum temperature (°C *)	+110	+110	+110	+100
Compression set DIN 53517, 24 hours /70°C (%)	7.0	8.0	5.0	13.0
Characteristics:				
Wear resistance	3	3	3	4
Tear resistance	3	3	3	3
Resistance to weather and ozone	3	3	3	3
Resistance to hydrolysis - water/steam	3	3	3	3
Resistance to chemicals - acids/bases	2-3	2-3	2-3	2
Resistance to mineral oil and gas	4	4	4	0
Permeability	4	4	4	2

0: Low 1: Limited 2: Medium 3: Considerable 4: High

Approvals/remarks:

- EUW-60: Hydrocheck, EN 681-1, WRAS (50°C), ACS XP P41 -250, EG (60°C), W270
- EUW-70: KTW D1/D2, W270, WRAS (60°C), ACS XP P 41-250, AS/NZS 4020, NSF-61, EN 681-1, AS 1646-2007, Önorm B5014, Hydrocheck, KIWA, GB5750
- EUW-75: W270, WRAS (50°C), ACS XP P 41-250, EN 681-1, AS/NZS 4020, Hydrocheck, KIWA
- EUW-80: KTW D1/D2, W270, WRAS, ACS XP P 41-250, EN 681-1, Hydrocheck
- EUW-85: WRAS, EG (50°C), W270
- EDK-70: AWWA C509, NSF-61
- NGW-55:
- NGW-70: EN 682 type GBL, KTW D2
- NGW-90: NSF-61
- SAK-70: UL-listed 22.06.1993

Above mentioned results are based on laboratory tests and must be evaluated for specific articles and applications.

Fire may create small amounts of hydrogen sulphide, and carbon dioxide. Disposal by incineration in compliance with local regulations.

*) Different temperature restrictions may apply to valves due to bonding between metal and rubber



FACE TO FACE DIMENSIONS AND HEIGHTS ABOVE CENTER LINE:

Valves to EN 1074-1 & 2, type A (DIN 3352 part 4)

Valves to EN 1074-1 & 2, type B (BS 5163)

DN	Face to face dim. to EN 558-F14 (DIN 3202 part 1, F4) L mm	Face to face dim. to EN 558-F15 (DIN 3202 part 1, F5) L mm	Height above center line H mm	Face to face dim. to EN 558-F3 (BS 5163) L mm	Height above center line H mm
25	-	120	180	-	-
32	-	140	190	-	-
40	140	240	194	-	-
50	150	250	208	178	279
65	170	270	244	190	279
80	180	280	282	203	294
100	190	300	305	229	324
125	200	325	346	254	324
150	210	350	401	267	429
200	230	400	490	292	531
250	250	450	625	330	614
300	270	500	740	356	690
350	290	550	940/924	381	867
400	310	600	940/951	406	867
450	330	650	951*/1157**/1130***	-	-
500	350	700	951*/1142**/1130***	-	-
600	390	800	- /1285**/1270***	-	-
700	430	-	1622	-	-
800	470	1000	1672**/1591***	-	-
900	510	-	2118	-	-
1000	550	-	2067	-	-

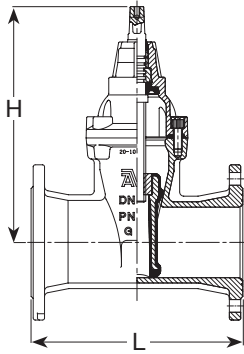

* Series 02 ** Series 06 *** Series 55

STEM DIMENSIONS AND HEIGHTS ABOVE CENTER LINE:

Service connection valve

Valves to EN 1074-1 & 2, type A (DIN 3352 part 4)

Valves to EN 1074-1 & 2, type B (BS 5163)

DN	H mm	F mm	F1 mm	F2 mm	F mm	F1 mm	F2 mm	F mm	F2 mm	F2 mm
25	180	12,3	15,4	35	-	-	-	-	-	-
32	190	12,3	15,4	35	-	-	-	-	-	-
40	203	12,3	15,4	35	14	16	30	-	-	-
50	213	12,3	15,4	35	14	16	30	19	22,4	38
65	-	-	-	-	17	20	34	19	22,4	38
80	-	-	-	-	17	20	34	19	22,4	38
100	-	-	-	-	19	22	34	19	22,4	38
125	-	-	-	-	19	22	34	19	22,4	38
150	-	-	-	-	19	22	34	24	27,7	42
200	-	-	-	-	24	28	34	27	31,2	47
250	-	-	-	-	27	31	47	27	31,2	47
300	-	-	-	-	27	31	47	27	31,2	47
350	-	-	-	-	32	37	55	32	36,9	55
400	-	-	-	-	32	37	55	32	36,9	55
450*	-	-	-	-	32	36,9	55	-	-	-
500*	-	-	-	-	32	36,9	55	-	-	-
450**	-	-	-	-	Ø30/40	Ø30/40	75	-	-	-
500**	-	-	-	-	Ø30/40	Ø30/40	84	-	-	-
600**	-	-	-	-	Ø30/40	Ø30/40	83.5	-	-	-
700	-	-	-	-	Ø40	Ø40	83.5	-	-	-
800	-	-	-	-	Ø40	Ø40	83.5	-	-	-
900	-	-	-	-	Ø40	Ø40	83.5	-	-	-
1000	-	-	-	-	Ø40	Ø40	83.5	-	-	-

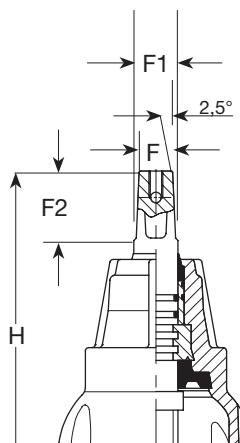

* series 02 and 20

** Ø30 for series 06 - Ø40 for series 55/30



FLANGES AND BOLTS

DN	PN	Bolt (no. x M ¹ x L ²)	Nut (no. x M ¹)	Washer (no. x D1 ³ x D2 ⁴ x thickness)
50/65	10/16	4 x M16x65	4 x M16	8 x 17x30x3
80/100/125	10/16	8 x M16x65	8 x M16	16 x 17x30x3
150	10/16	8 x M20x70	8 x M20	16 x 21x37x3
200	10	8 x M20x75	8 x M20	16 x 21x37x3
200	16	12 x M20x75	12 x M20	24 x 21x37x3
250	10	12 x M20x75	12 x M20	24 x 21x37x3
250	16	12 x M24x80	12 x M24	24 x 25x44x4
300	10	12 x M20x85	12 x M20	24 x 21x37x3
300	16	12 x M24x85	12 x M24	24 x 25x44x4
350	10	16 x M20x90	16 x M20	32 x 21x37x3
350	16	16 x M24x95	16 x M24	32 x 25x44x4
400	10	16 x M24x100	16 x M24	32 x 25x44x4
400	16	16 x M27x100	16 x M27	32 x 28x50x4
450	10	20 x M24x100	20 x M24	40 x 25x44x4
450	16	20 x M27x100	20 x M27	40 x 28x50x4
500	10	20 x M24x110	20 x M24	40 x 25x44x4
500	16	20 x M30x110	20 x M30	40 x 31x56x4
600	10	20 x M27x120	20 x M27	40 x 28x50x4
600	16	20 x M33x120	20 x M33	40 x 34x68x4
700	10	24 x M27x105	24 x M27	48 x 28x50x8
700	16	24 x M33x115	24 x M33	48 x 34x60x8
800	10	24 x M30x120	24 x M30	48 x 31x56x8
800	16	24 x M36x130	24 x M36	48 x 37x66x8
900	10	28 x M30x130	28 x M30	56 x 31x56x8
900	16	28 x M36x140	28 x M36	56 x 37x66x8
1000	10	28 x M33x140	28 x M33	56 x 34x60x8
1000	16	28 x M39x160	28 x M39	56 x 40x72x8
1200	10	32 x M36x150	32 x M36	64 x 37x66x8
1200	16	32 x M45x180	32 x M45	64 x 46x85x8

¹ Size ² Length ³ Internal diameter ⁴ External diameter

Standard flange drillings to ISO 7005 part 2 (EN 1092-2: 1997, DIN 2501):

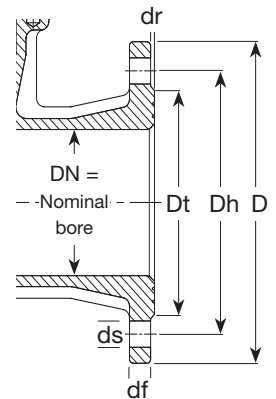

DN	D mm		Dt mm		Dh mm		df mm		dr mm	ds mm		Number of Holes		Bolt size	
	PN10	PN16	PN10	PN16	PN10	PN16	PN10	PN16		PN10	PN16	PN10	PN16	PN10	PN16
40	150		83		110		16		3	19		4		M16	
50	165		102		125		16		3	19		4		M16	
65	185		122		145		16		3	19		4		M16	
80	200		138		160		16		3	19		8		M16	
100	220		158		180		16		3	19		8		M16	
125	250		188		210		16		3	19		8		M16	
150	285		212		240		16		3	23		8		M20	
200	340		268		295	295	17	3	23	23	8	12		M20	
250	400		320		350	355	19	3	23	28	12	12	M20	M24	
300	455		367		400	410	21	4	23	28	12	12	M20	M24	
350	520		430		460	470	23	4	23	28	16	16	M20	M24	
400	580		482		515	525	24	4	28	31	16	16	M24	M27	
450	640	530	548		565	585	24	4	28	31	20	20	M24	M27	
500	715	582	609		620	650	28	4	28	34	20	20	M24	M30	
600	840	682	720		725	770	29	5	31	37	20	20	M27	M33	
700	895	910	800	795	840	840	28	35	5	31	37	24	22	M27	M33
800	1015	1025	905	900	950	950	30	38	5	34	41	24	24	M30	M36
900	1115	1125	1005	1000	1050	1050	33	42	5	34	41	28	28	M30	M36
1000	1230	1255	1110	1115	1160	1170	35	45	5	37	44	28	28	M33	M39
1200	1455	1485	1330	1330	1380	1390	40	52	5	41	50	32	32	M36	M45



FLOW, KV VALUES AND ZETA VALUES FOR GATE VALVES, RESILIENT- AND METAL SEATED APPENDIX 6

Calculated flow (m³/hr) going through a nominal valve size (DN40 = inside dia of 40 mm) at different flow velocities

Water velocity (m/sec)	DN40	DN50	DN65	DN80	DN100	DN125	DN150	DN200	DN250	DN300	DN350	DN400	DN450	DN500	DN600	DN700	DN800	DN900	DN1000
1	5	7	12	18	28	44	64	113	177	254	346	452	573	707	1018	1385	1810	2290	2827
1,5	7	11	18	27	42	66	95	170	265	382	520	679	859	1060	1527	2078	2714	3435	4241
2	9	14	24	36	57	88	127	226	353	509	693	905	1145	1414	2036	2771	3619	4580	5655
2,5	11	18	30	45	71	110	159	283	442	636	866	1131	1431	1767	2545	3464	4524	5726	7069
3	14	21	36	54	85	133	191	339	530	763	1039	1357	1718	2121	3054	4156	5429	6871	8482
3,5	16	25	42	63	99	155	223	396	619	891	1212	1583	2004	2474	3563	4849	6333	8016	9896
4	18	28	48	72	113	177	254	452	707	1018	1385	1810	2290	2827	4072	5542	7238	9161	11310
4,5	20	32	54	81	127	199	286	509	795	1145	1559	2036	2576	3181	4580	6234	8143	10306	12723
5	23	35	60	90	141	221	318	565	884	1272	1732	2262	2863	3534	5089	6927	9048	11451	14137

Hydraulic values, fully open valve

	DN40	DN50	DN65	DN80	DN100	DN125	DN150	DN200	DN250	DN300	DN350	DN400	DN450	DN500	DN600	DN700	DN800	DN900	DN1000
Kv (m³/hr - 1 bar)	310	555	650	1050	1945	2770	5715	7755	15405	27295	37150	48520	61410	75815	109175	148600	194090	229572	283422
Cv (Usg/min - 1 psi)	363	649	761	1229	2276	3241	6687	9073	18024	31935	43466	56768	71850	88704	127735	173862	227085	268599	331604
Zeta	0.04	0.03	0.07	0.06	0.04	0.05	0.02	0.04	0.03	0.02	0.02	0.02	0.02	0.02	0.02	0.02	0.02	0.02	0.02

NOTE: Hydraulic figures are based on tests or calculations, depending on size. Value uncertainty as per ref EN1267

Definitions / formulas:

Kv-value: Actual flow of water (m³/hr) creating pressure loss of 1 bar.

Pressure loss coefficient Zeta (K) value: Ratio of static to dynamic pressure loss.

Zeta (K) = Diff pressure / (500 X V²)

Diff pressure (Pa)

V: Water flow velocity (m/sec)

Actual diff pressure (bar) = (Q / Kv)²

Q: Actual water flow (m³/hr)

Kv values, valve in semi-open position. Percentage, based on turns of stem, from closed to fully open valve.

Opening of valve	DN40	DN50	DN65	DN80	DN100	DN125	DN150	DN200	DN250	DN300	DN350	DN400	DN450	DN500	DN600	DN700	DN800	DN900	DN1000
10%	15	20	25	40	70	130	145	315	410	535	725	950	1200	1480	2135	2905	3790	4485	5538
20%	20	30	35	55	100	185	215	450	615	825	1125	1470	1860	2295	3305	4495	5870	9930	12259
30%	30	45	50	80	145	255	325	640	915	1280	1740	2275	2875	3550	5115	6960	9095	15497	19132
40%	45	65	70	115	210	360	490	915	1370	1980	2695	3520	4455	5500	7920	10780	14080	22703	28029
50%	60	90	105	165	305	505	740	1305	2055	3065	4175	5450	6900	8515	12265	16690	21800	30812	38040
75%	135	225	260	420	770	1185	2055	3180	5625	9150	12450	16260	20580	25410	36590	49805	65050	63740	78692
100%	310	555	650	1050	1945	2770	5715	7755	15405	27295	37150	48520	61410	75815	109175	148600	194090	229572	283422

NOTE: Hydraulic figures are based on tests or calculations, depending on size. Value uncertainty as per ref EN1267

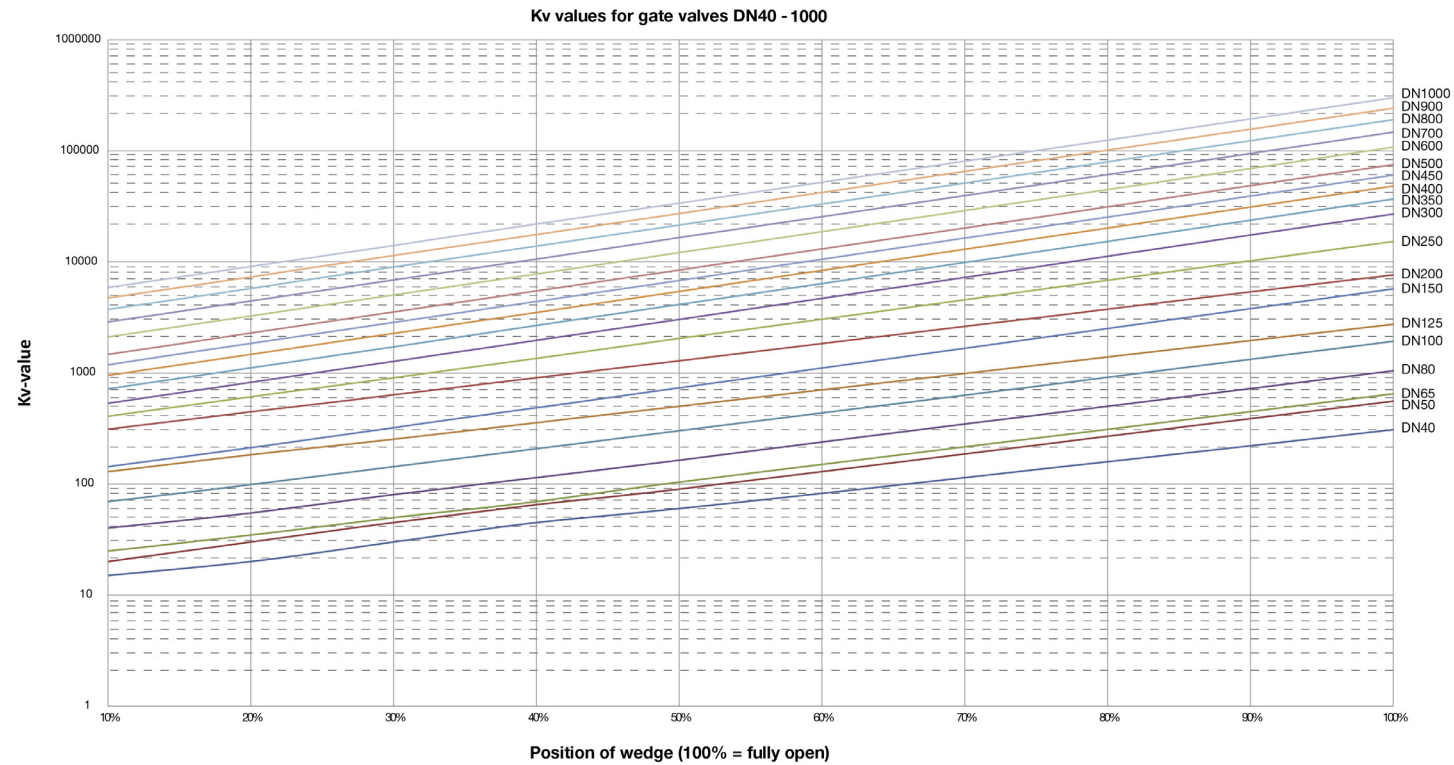

Zeta (K) values, valve in semi-open positions. Percentage, is based on turns of stem, from closed to fully open valve.

Opening of valve	DN40	DN50	DN65	DN80	DN100	DN125	DN150	DN200	DN250	DN300	DN350	DN400	DN450	DN500	DN600	DN700	DN800	DN900	DN1000
10%	18	25	46	41	33	23	39	26	37	45	46	45	46	46	46	46	46	52.09	52.09
20%	10	11	23	22	16	11	18	13	17	19	19	19	19	19	19	19	19	10.63	10.63
30%	5	5	11	10	8	6	8	6	7	8	8	8	8	8	8	8	8	4.36	4.36
40%	2	2	6	5	4	3	3	3	3	3	3	3	3	3	3	3	3	2.03	2.03
50%	1	1	3	2	2	2	1	2	1	1	1	1	1	1	1	1	1	1.10	1.10
75%	0.23	0.20	0.42	0.37	0.27	0.28	0.19	0.25	0.20	0.16	0.16	0.16	0.16	0.16	0.16	0.16	0.16	0.26	0.26
100%	0.04	0.03	0.07	0.06	0.04	0.05	0.02	0.04	0.03	0.02	0.02	0.02	0.02	0.02	0.02	0.02	0.02	0.02	0.02

NOTE: Hydraulic figures are based on both tests and calculations, depending on size. Value uncertainty, ref EN1267

Zeta (K) for gate valves DN40 - 1000

