

Operating and installation instructions

Butterfly valves

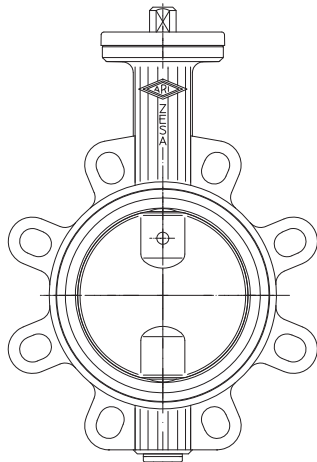

BR 012 - ZESA®

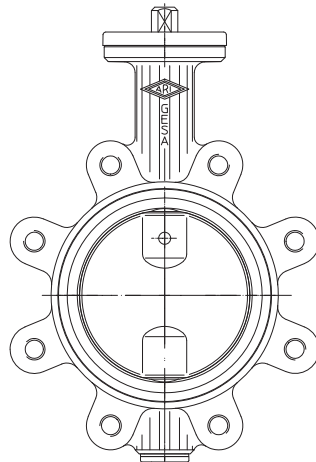

BR 013 - GESA®

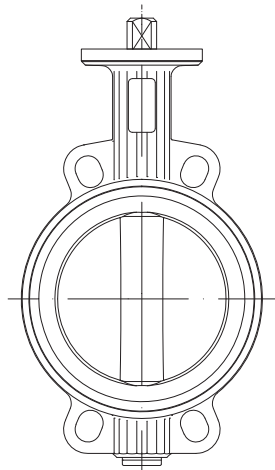

BR 014 - ZIVA®-Z

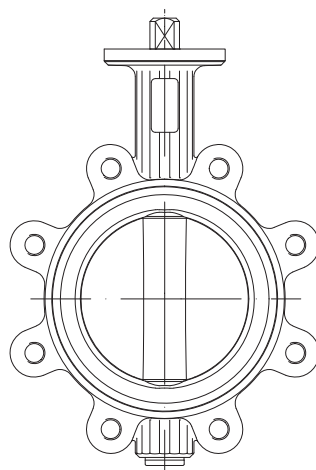

BR 015 - ZIVA®-G

Contents

1.0 General information on operating instructions	2-2	5.5 Converting or retrofitting lever (ZIVA®-Z / ZIVA®-G).....	2-11
2.0 Notes on possible dangers	2-2	5.6 Installation instructions for mounting in pipe systems	2-12
2.1 Significance of symbols	2-2	6.0 Putting the valve into operation	2-13
2.2 Explanatory notes on safety information	2-2	7.0 Care and maintenance	2-13
3.0 Storage and transport	2-2	7.1 Sealing ring and O-ring seal (ZIVA®-Z / ZIVA®-G)....	2-14
4.0 Description	2-3	7.2 Tightening torques.....	2-15
4.1 Scope of applications	2-3	7.2.1 Bolt material A4-70	2-15
4.2 Operating principles	2-3	7.2.2 Bolt material 4.6 - ARI-Data sheet (acc. to EN1515-1	2-16
4.3 Diagram - assembly	2-4	7.2.3 Bolt material 5.6 - acc. to EN1515-4.....	2-16
4.4 Technical data - remarks	2-6	8.0 Troubleshooting	2-17
4.5 Marking	2-7	9.0 Troubleshooting table	2-17
5.0 Installation	2-8	10.0 Dismantling the valve or the top part ..	2-18
5.1 General remarks on installation	2-8	11.0 Regional Standards	2-18
5.2 Installation of accessories	2-8	12.0 Warranty / Guarantee	2-18
5.3 Conversion from notch lever to lock lever	2-9		
5.4 Retrofitting the THERMO-Appliance (ZESA®THEA / GESA®THEA).....	2-10		

1.0 General information on operating instructions

These operating instructions provide information on mounting and maintaining the valves. Please contact the supplier or the manufacturer in case of problems which cannot be solved by reference to the operating instructions.

They are binding for transport, storage, installation, start-up, operation, maintenance and repair.

The notes and warnings must be observed and adhered to.

- Handling and all other work must be carried out by expert personnel or all activities supervised and checked.

It is the owner's responsibility to define areas of responsibility and competence and to supervise personnel.

- In addition, current regional safety requirements must be applied and observed when taking the valves out of service as well as when maintaining and repairing them.

The manufacturer reserves the right to introduce technical modifications or improvements at any time.

These operating instructions comply with the requirements of EU Directives.

2.0 Notes on possible dangers

2.1 Significance of symbols



Warning of general danger.

2.2 Explanatory notes on safety information

In these operating and installation instructions dangers, risks and items of safety information are highlighted to attract special attention.

Information marked with the above symbol and "**ATTENTION!**" describe practices, a failure to comply with which can result in serious injury or danger of death for users or third parties or in material damage to the system or the environment. It is vital to comply with these practices and to monitor compliance.

All other information not specifically emphasised such as transport, installation, operating and maintenance instructions as well as technical data (in the operating instructions, product documentation and on the device itself) must also be complied with to the fullest extent in order to avoid faults which in turn can cause serious injury to persons or damage to property.

3.0 Storage and transport

	<p>ATTENTION!</p> <ul style="list-style-type: none">- Protect against external force (like impact, vibration, etc.).- Valve mountings such as actuators, handwheels, hoods must not be used to take external forces, e.g. they are not designed for use as climbing aids or as attachment points for lifting gear.- Suitable materials handling and lifting equipment should be used. <p>See catalog sheet for weights.</p>
---	--

- At -20 °C to +65 °C.

- The paint is a base coat to protect against corrosion during transportation and storage. Do not damage paint protection.

4.0 Description

4.1 Scope of applications

Butterfly valves are used for “interruption of liquids and gases”.



ATTENTION !

- Refer to the data sheet for applications, limits on use and possibilities.
- Certain media require or preclude the use of special materials.
- The valves are designed for standard operating conditions. If conditions exceed these requirements, e.g. aggressive or abrasive media, the operator should state the higher requirements when ordering.
- Valves made from grey cast iron are not authorised for use in systems subject to TRD 110.

The information complies to the Pressure Equipment Directive 2014/68/EU.

It is the responsibility of the machine planner to ensure compliance.

The special markings on the valve must be taken into account.

Refer to the catalogue sheet to see which materials are used in standard versions.

Please contact the supplier or the manufacturer if you have any questions.

4.2 Operating principles

The valve is closed by turning the disc shaft clockwise.

The shaft moves through 90°.

4.3 Diagram - assembly

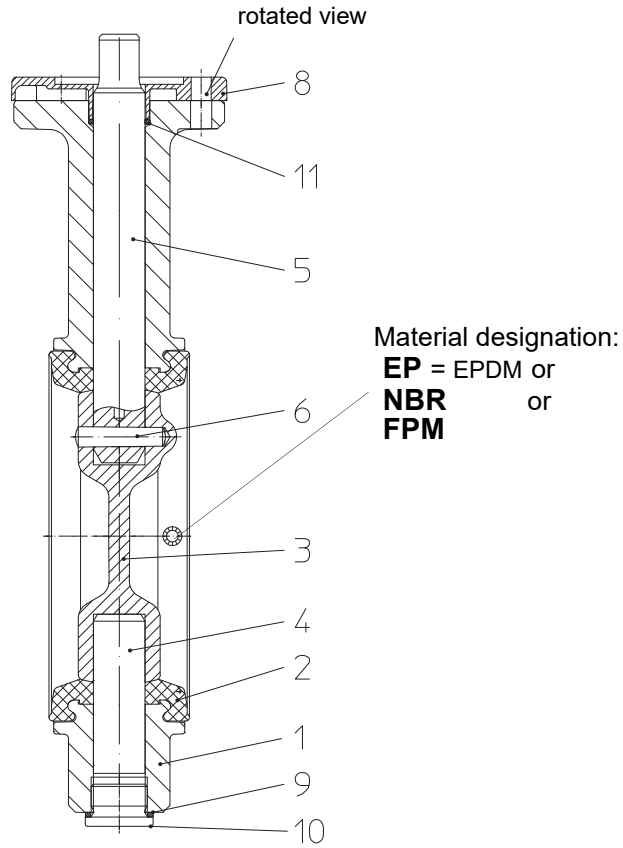

Fig. 1: Butterfly valve ZESA[®] / GESA[®]

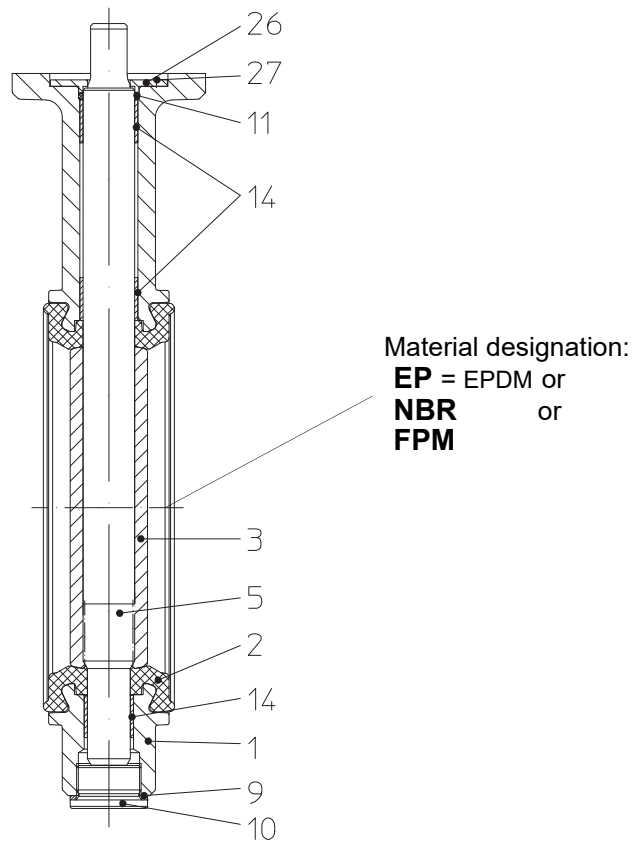

Fig. 2: Butterfly valve ZIVA[®]-Z / ZIVA[®]-G

Refer to the data sheet for information about materials with designations and figure numbers.

Actuation arrangements

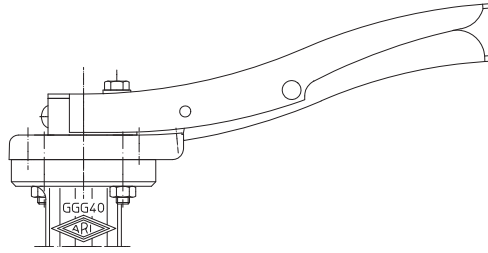

Fig. 3: Notch lever ZESA® / GESA®

- The detent pin of the lower lever must be fully disengaged to move the lever.

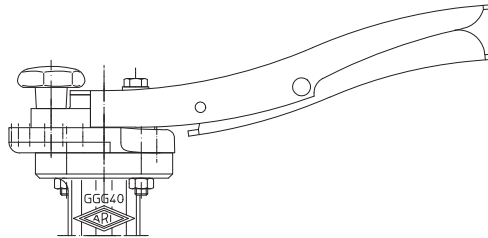

Fig. 4: Lock lever ZESA® / GESA®

- The star knob screw must be slackened before and tightened again after moving the lever.

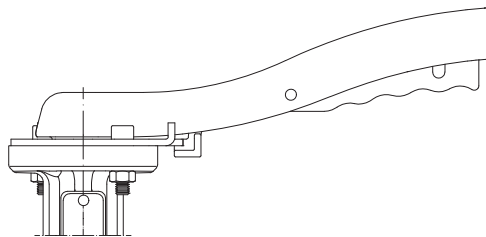

Fig. 5: Notch lever ZIVA®-Z / ZIVA®-G

- The detent pin of the lower lever must be fully disengaged to move the lever.

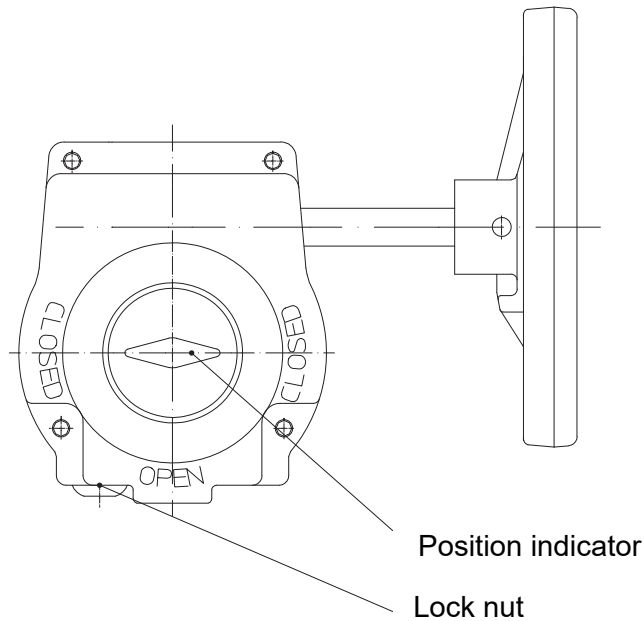

Fig. 6: Worm gear ZESA[®]/GESA[®] and ZIVA[®]-Z/ ZIVA[®]-G

- Gear type (actuation by hand wheel, clockwise for closing).

The CLOSE-position can be adjusted by $\pm 5^\circ$ by a stop screw.

The stop screws are self-sealing and self-locking (refer to Fig. 7).

- Refer to separate operating and maintenance manual for drive (electric or pneumatic).

4.4 Technical data - remarks





for

- **Principal dimensions**

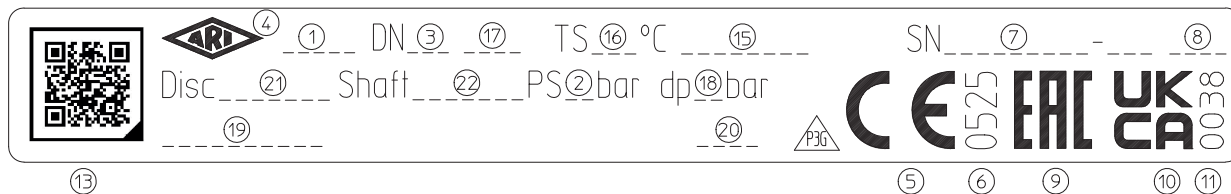
- **Pressure-temperature-ratings, etc.** refer to data sheet.

4.5 Marking



No.	Value
1	Figure / Product
2	Nominal pressure [PS]
3	Nominal diameter [DN]
4	Manufactured by ARI-Armaturen 
5	CE marking 
6	Notified body [0525]
7	Serial number [SN]
8	Year of manufacture [JJJJ]
9	EAC marking 
10	UKCA marking 
11	Notified body [0038]
12	Marking at approval
13	QR-Code [ARI-ID]
15	Flange drilling [drilled ...]
16	Permissible temperature [TS]
17	Material of the sealing ring
18	differential pressure [dp]
19	Approval/Registration
20	Thermometer [THEA]
21	Material of the disc
22	Material of the stem
For address of manufacturer, refer to Point 12.0 Warranty / Guarantee	

According to the Pressure Equipment Directive table 6, annex II, valves without safety function are only allowed to bear the CE-marking DN32 onwards.

5.0 Installation

5.1 General remarks on installation

The following points should be taken into account besides the general principles governing installation work:



ATTENTION !

- Remove flange covers if present.
- The interior of valve and pipeline must be free from foreign particles.
- The direction of flow need not be taken into account.
- Steam line systems should be designed to prevent water accumulation.
- Lay pipelines so that damaging transverse, bending and torsional forces are avoided.
- Protect valves from dirt during construction work.
- Connection flanges must mate exactly.
- Valve mountings such as actuators, handwheels, hoods must not be used to take external forces, e.g. they are not designed for use as climbing aids, or as connecting points for lifting gear.
- Flooding of the butterfly valve is not permissible.
- Suitable materials handling and lifting equipment should be used.
See data sheet for weights.
- The shaft can be in any position except for DN350 up to DN600 (preferably horizontal shaft).
- No gaskets required between flanges, flexible gaskets are not allowed.
- The butterfly valve must be installed in open position if possible, but the disc should not protrude beyond the housing.
- Large actuators with horizontal application must be supported.
- Avoid damage to the rubber sheathing during handling, storage and installation.
- Do not heat the valve (e.g. by welding, grinding, etc.) above its service temperature (refer to data sheets).
- Protect actuators from excessive ambient temperatures (refer to operating instructions for actuator).
- If the butterfly valve is in operation as a pipeend valve, regard DIN EN 294 point 5.

- Planners / construction companies or operators are responsible for positioning and installing products.
- The valves are designed for application, not influenced from weather.
- For application outside or in adverse environments like corrosion-promoting conditions (sea water, chemical vapours, etc.), special constructions or protective measures are recommended.
- **The valves are not permitted for subsurface installation.**

5.2 Installation of accessories

Optional accessories (e.g. limit switches) supplies with valves must be fitted as required for their functions as shown in the plants of the plant.

5.3 Conversion from notch lever to lock lever

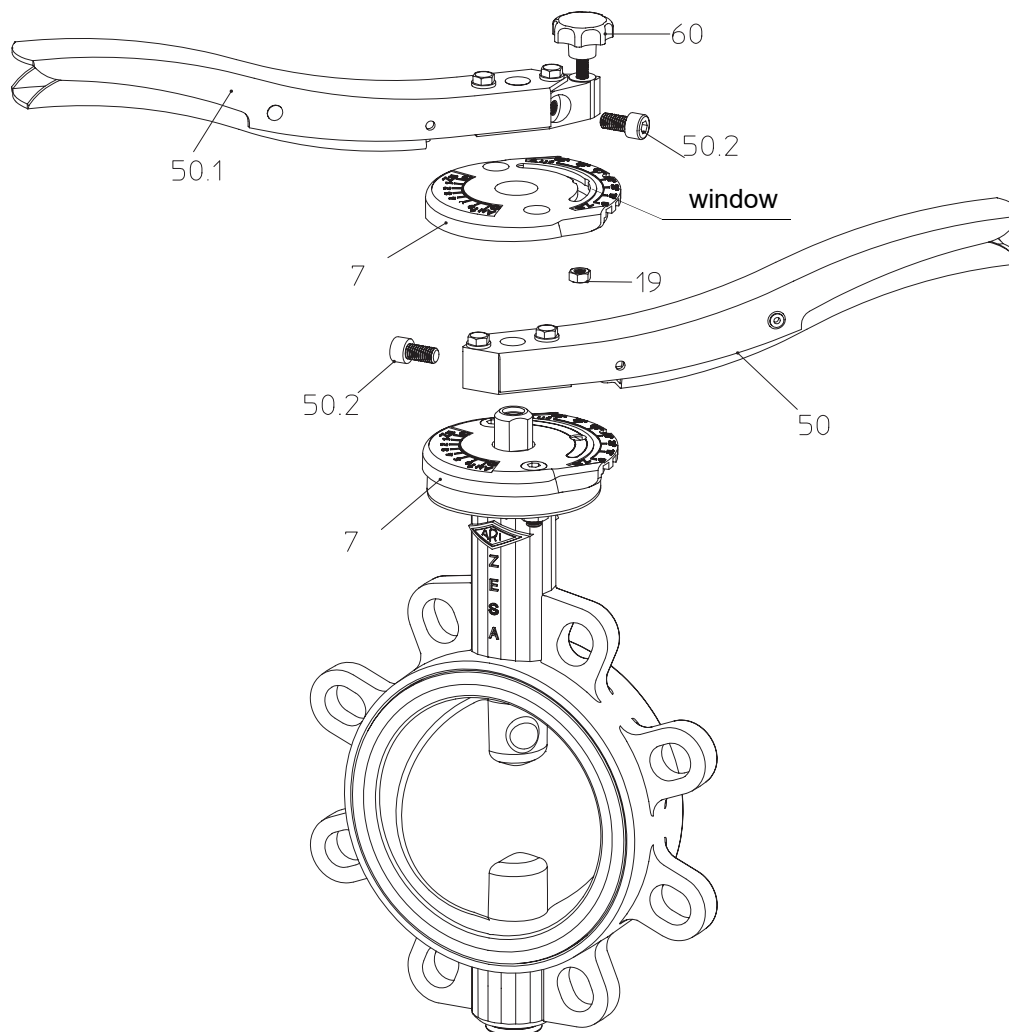

Fig. 7

The notch lever cap (pos. 7) can be used for the conversion.

- Set notch lever (pos. 50) to notch position 4.
- Slacken socket screw (pos. 50.2 / SW 5 of 6 mm AF).
- Remove notch lever (pos. 50).



ATTENTION !

The position of the valve disc is not positively located!

- Dismantle notch lever cap (pos. 7) and use a screwdriver to break out the window.
- Put the cap, with the nut (pos. 19) in it, in place and tighten it.
- Set the lock lever (pos. 50.1) in position as shown in the diagram.
- Tighten the socket screw (pos. 50.2).
- Insert star knob screw (pos. 60) through the hole at the end of the lock lever (pos. 50.1) and screw into the hex. nut (pos. 19).

If the lock lever must be on the same side as the original notch lever, the notch lever cap must be turned through 180°.

For the angle limit stop, an additional nut can be placed in the cap for a locking screw.

5.4 Retrofitting the THErm-Appliance (ZESA[®]THEA / GESA[®]THEA)

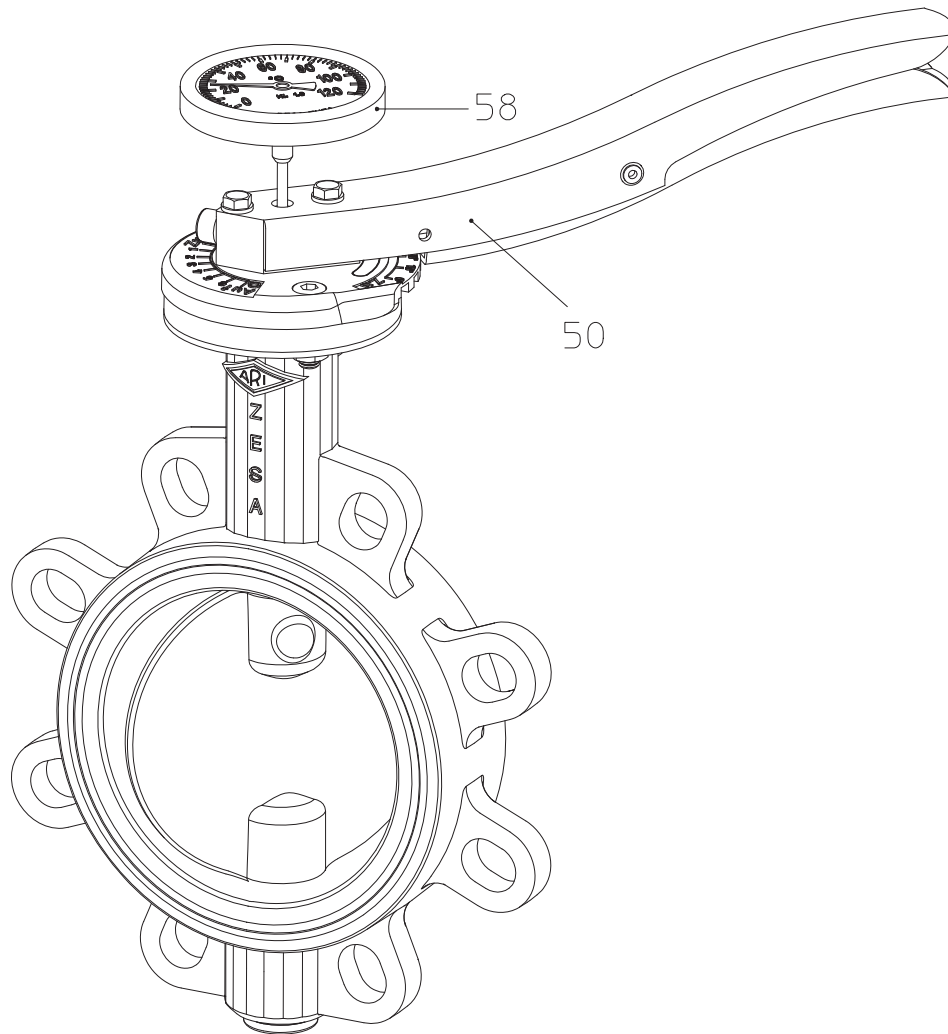

Fig. 8

- Remove sticker from the hole in the lever (pos. 50).
- Insert the THEA temperature indicator (pos. 58) into the hole down to the stop.

5.5 Converting or retrofitting lever (ZIVA[®]-Z / ZIVA[®]-G)

Retrofit in butterfly valve with free shaft end:

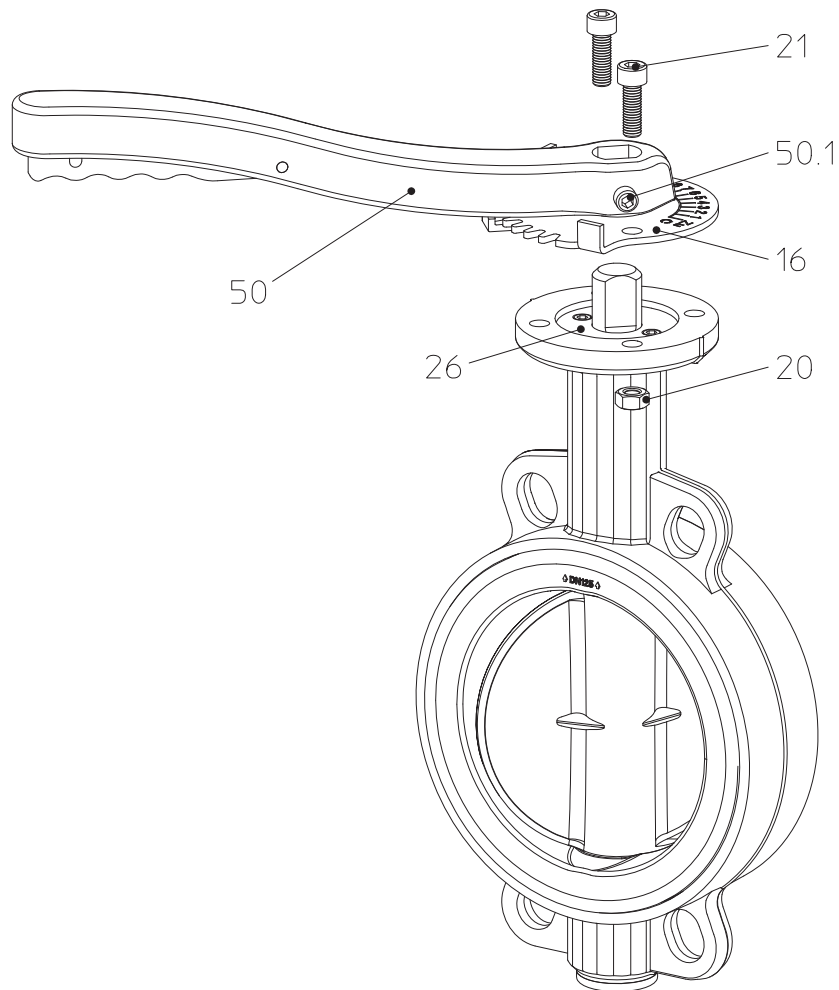

Fig. 9



ATTENTION !

- Do not remove shaft blowout protection (pos. 26) under pressure.
(see point 10.0 Dismantling the valve or the top part)
- The valve disc is not fixed in position without an actuating element!

- Slacken setscrew (pos. 50.1),
- Mount notch lever (pos. 50) on shaft end together with the notch disc (pos. 16)
(notch lever aligned with notch disc),
- Turn notch lever (pos. 50) until drillings in notch disc (pos. 16) and body are aligned,
- Assemble and tighten cheese-head screw (pos. 21) and nut (pos. 20),
- Tighten set screw (pos. 50.1).

5.6 Installation instructions for mounting in pipe systems

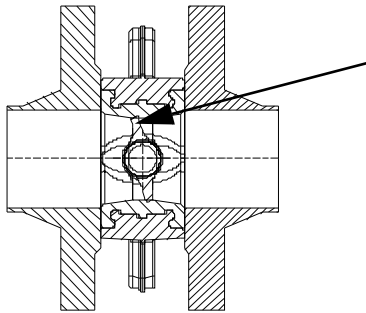

Fig. 10-A:

Note the open position of the disc at installation!

Fig. 10-A

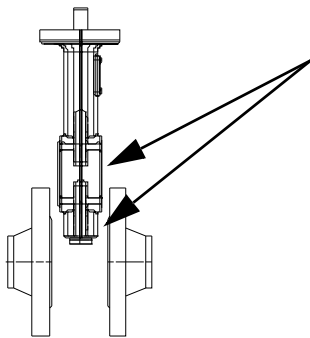

Fig. 10-B:

Care for sufficient space!

Fig. 10-B

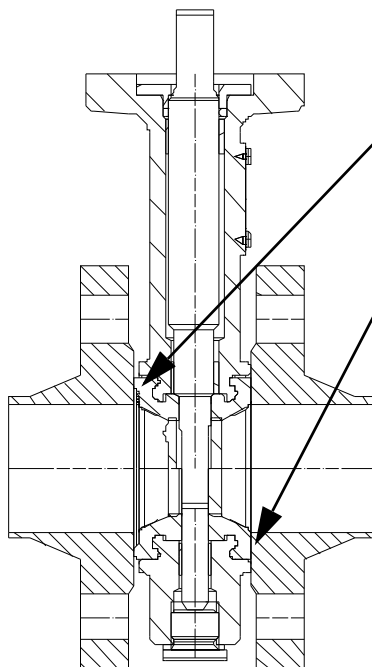

Fig. 10-C:

Step 1:

- Establish contact between sealing surface and facing.

Step 2:

- Flange contact to the valve body



ATTENTION !

Tightening screws crosswise!



ATTENTION !

The actual screw length required depends on the installation components used on site.

Screw lengths must be checked by the customer before ordering

Fig. 10-C

6.0 Putting the valve into operation



ATTENTION !

- Before putting the valve into operation, check the material, pressure, temperature and direction of flow.
 - As a general rule, we recommend that you do not install valves immediately downstream from pipe bends or tees.
You should allow a section equivalent to at least 2 x DN before and 6 x DN after the valve.
 - Regional safety instructions must be adhered to.
 - Residues in piping and valves (dirt, weld beads, etc.) inevitably lead to leakage and / or damage.
 - Touching the valve when it is operating at high (> 50 °C) or low (< 0 °C) media temperatures can cause injury.
Affix a warning notice or provide protective insulation as appropriate.
- Before putting a new plant into operation or restarting a plant after repairs or modification, always make sure that:
- All work has been completed correctly.
 - The valve is in the correct position for its function.
 - Safety devices have been attached.

7.0 Care and maintenance

Maintenance and maintenance-intervals have to be defined by the operator according to the requirements.



ATTENTION !

- It is advisable to actuate the valve at least once a month.
- When used as an end-blockage, a safety precaution (e.g. plug-in disc, blind flange etc.) is demanded by maintenance works.

7.1 Sealing ring and O-ring seal (ZIVA[®]-Z / ZIVA[®]-G)

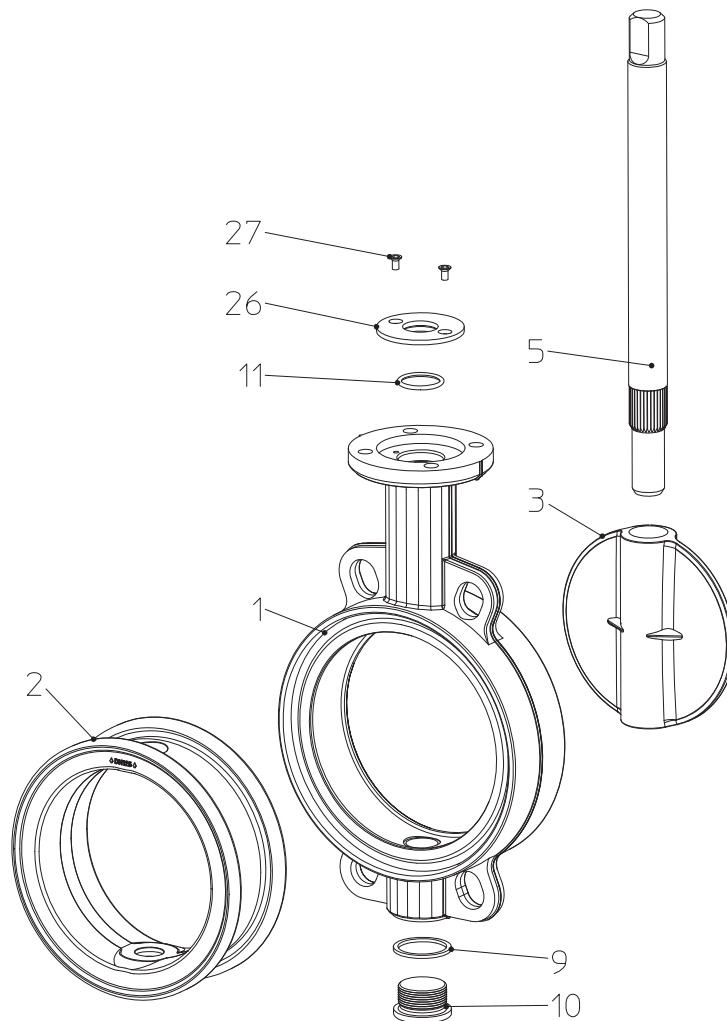

fig. 10

- Observe safety instructions
- Sealing ring (pos. 2) when changing
 Lubricant: e.g. Berusoft 30 valve grease
 obtainable from: Carl Bechem GmbH, Weststrasse 120, D-58089 Hagen
 or a lubricant suitable for this application.



ATTENTION!

- Always ensure that the lubricant is compatible with the medium.
- It is not safe to replace the O-ring seal (pos. 11) until the system has cooled down and the plant is pressureless.
- For safety reasons we recommend that the O-ring seal (pos. 11) only be changed when disassembled.
- Prior to disassembling the butterfly valve note points 10.0 and 11.0.
- When the butterfly valve is activated there is a crushing hazard between valve disc and body.
- Maintenance work inside the pipeline (large nominal diameters) should only be carried out when the butterfly valve is safely deactivated (disconnect actuator from power supply).

7.2 Tightening torques

Bolt torques acc. to Roloff-obtain to $0,9xR_{P0,2}$ and RT
 $\mu_G = 0,12$ / Flange hole acc. to EN1092-1

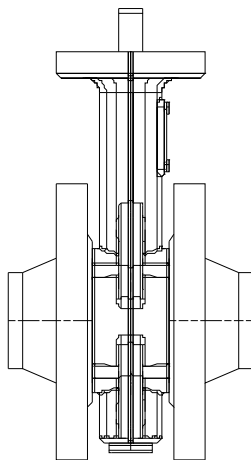

The actually allowable locking torque can be less than the values shown in the table. This can depend on the kind of bolt material or lubricant is used.

Minimum depth for ZIVA[®]-G and GESA[®]:

Thread reach $l_e = 1 \times d_{\text{bolt}}$ (steel, cast steel, nodular iron)

Thread reach $l_e = 1,25 \times d_{\text{bolt}}$ (cast iron, copper alloy)

7.2.1 Bolt material A4-70

M10	=	29 Nm,	$R_{P0,2} = 450 \text{ N/mm}^2$
M12	=	52 Nm,	$R_{P0,2} = 450 \text{ N/mm}^2$
M16	=	128 Nm,	$R_{P0,2} = 450 \text{ N/mm}^2$
M20	=	249 Nm,	$R_{P0,2} = 450 \text{ N/mm}^2$
M24	=	238 Nm,	$R_{P0,2} = 250 \text{ N/mm}^2$
M27	=	351 Nm,	$R_{P0,2} = 250 \text{ N/mm}^2$
M30	=	477 Nm,	$R_{P0,2} = 250 \text{ N/mm}^2$
M33	=	645 Nm,	$R_{P0,2} = 250 \text{ N/mm}^2$
M36	=	829 Nm,	$R_{P0,2} = 250 \text{ N/mm}^2$

7.2.2 Bolt material 4.6 - ARI-Data sheet (acc. to EN1515-1)

M10	=	16 Nm,	R _{P0,2} =	240 N/mm ²
M12	=	28 Nm,	R _{P0,2} =	240 N/mm ²
M16	=	68 Nm,	R _{P0,2} =	240 N/mm ²
M20	=	133 Nm,	R _{P0,2} =	240 N/mm ²
M24	=	228 Nm,	R _{P0,2} =	240 N/mm ²
M27	=	337 Nm,	R _{P0,2} =	240 N/mm ²
M30	=	458 Nm,	R _{P0,2} =	240 N/mm ²
M33	=	619 Nm,	R _{P0,2} =	240 N/mm ²
M36	=	796 Nm,	R _{P0,2} =	240 N/mm ²

7.2.3 Bolt material 5.6 - acc. to EN1515-4

M10	=	20 Nm,	R _{P0,2} =	300 N/mm ²
M12	=	35 Nm,	R _{P0,2} =	300 N/mm ²
M16	=	85 Nm,	R _{P0,2} =	300 N/mm ²
M20	=	166 Nm,	R _{P0,2} =	300 N/mm ²
M24	=	286 Nm,	R _{P0,2} =	300 N/mm ²
M27	=	421 Nm,	R _{P0,2} =	300 N/mm ²
M30	=	572 Nm,	R _{P0,2} =	300 N/mm ²
M33	=	774 Nm,	R _{P0,2} =	300 N/mm ²
M36	=	995 Nm,	R _{P0,2} =	300 N/mm ²

8.0 Troubleshooting

In the event of malfunction or faulty operating performance check that the installation and adjustment work has been carried out and completed in accordance with these Operating Instructions.

	<p>ATTENTION ! <i>- It is essential that the safety regulations are observed when identifying faults.</i></p>
---	---

If malfunctions cannot be eliminated with the help of the following table “9.0 Troubleshooting table”, the supplier or manufacturer should be consulted.

9.0 Troubleshooting table

	<p>ATTENTION ! <i>- read point 10.0 and 11.0 prior to dismantling and repair work!</i> <i>- read point 6.0 before restarting the plant !</i></p>
---	---

Fault	Possible cause	Corrective measures
No flow	Valve closed.	Open valve.
Little flow	Valve not sufficiently open.	Open valve.
	Strainer sieve clogged.	Clean / replace sieve.
	Piping system clogged.	Check piping system.
Valve is impossible or difficult to open or close	Service conditions (e.g. medium, temperature) outside permissible limits.	Replace valve. Consult supplier or manufacturer.
	Power failure.	Check power supply.
	Wrong direction of rotation.	Turn in correct direction (clockwise for opening).
Valve leaking	Not properly closed.	Close valve properly or readjust limit switch/stop screw.
	Pressure difference too high.	Check plant.
	Medium contaminated.	Clean valve. Install strainer sieve <i>upstream</i> of valve.
	Lining/sealing ring (Fig. 1-2, item 2) or valve disc (Fig. 1-2, item 3) damaged by foreign bodies or medium	Replace valve. Consult supplier or manufacturer.
Valve with locking device cannot be opened	Locking device tightened.	Slacken locking device.

10.0 Dismantling the valve or the top part



ATTENTION !

The following points must be observed:

- *Pressureless piping system.*
- *Medium must be cool.*
- *Plant must be drained.*
- *Purge piping systems in case of caustic, inflammable, aggressive or toxic media.*

11.0 Regional Standards

- ÖVGW

12.0 Warranty / Guarantee

The extent and period of warranty cover are specified in the "Standard Terms and Conditions of Albert Richter GmbH & Co. KG" valid at the time of delivery or, by way of departure, in the contract of sale itself.

We guarantee freedom of faults in compliance with state-of-the-art technology and the confirmed application.

No warranty claims can be made for any damage caused as the result of incorrect handling or disregard of operating and installation instructions, technical data sheets and relevant regulations.

This warranty also does not cover any damage which occurs during operation under conditions deviating from those laid down by specifications or other agreements.

Justified complaints will be eliminated by repair carried out by us or by a specialist appointed by us.

No claims will be accepted beyond the scope of this warranty. The right to replacement delivery is excluded.

The warranty shall not cover maintenance work, installation of external parts, design modifications or natural wear.

Any damage incurred during transport should not be reported to us but rather to the competent cargo-handling depot, the railway company or carrier company immediately or else claims for replacements from these companies will be invalidated.

Importer to UK and responsible for compilation of the documentation:

ARI Armaturen UK Ltd
Energy House, Formal Industrial Park, Northway Lane, GL20 8GY Tewkesbury,
United Kingdom



ARI-Armaturen Albert Richter GmbH & Co. KG, D-33750 Schloß Holte-Stukenbrock
Telephone (+49 5207) 994-0 Telefax (+49 5207) 994-158 or 159
Internet: <https://www.ari-armaturen.com> E-mail: info.vertrieb@ari-armaturen.com