



MeiStream

Bulkmeter for cold potable water DN 40 ... 300

Main characteristics

- Meter with MID pattern approval acc. to annex MI001
- Exchangeable metrological unit with MID pattern approval acc. to annex MI001
- Unique measuring range; $Q_3/Q_1 \geq 100$
- High overload capability
- No straight inlet length necessary (U0D0 acc. to OIML R49:2013 and ISO 4064-1:2017)
- Installation position horizontal and vertical
- Meter body in short (WP) and long (WS) overall length acc. to DIN 19625 and ISO 4064-1:2017 available
- Meter can be submerged; protection class IP68
- Used materials are temperature resistant up to 70 °C
- Register prepared for HRI-Mei pick-up
- Use of optical pulsers type OD is still possible

APPLICATIONS

- Measurement for billing of cold potable water up to 50 °C
- Measurement of high flowrates e.g. in pumped pipes
- Measurement of low flow e. g. in light load periods
- For leakage detection

MATERIALS

Body	Cast iron (PN16) Ductile iron (PN40)
Metrological module	Engineering polymer
Rotor	Engineering polymer
We also use the following materials	Brass Stainless steel

ENVIRONMENTAL CONDITIONS

- According to ISO 4064-1:2017
- Environmental class O acc. to OIML R49-1:2013
- Environmental temperature: 5 °C ... 70 °C
- Mechanical environmental conditions: class M2

Available options

- Encoder register with different data protocols (M-Bus, Sensus, IEC 1107)
- BMF version free of copper alloy for aggressive water (DN 40 ... 150)
- Register with 7 digits without multiplier (DN 150 ... 300)
- Version for high pressure up to PN 40 (DN 50 ... 150)
- Version for use in hazardous area
- HRI-Mei factory mounted
- ¼" pressure monitoring port

Approval Mark

Meter cpl. and exchangeable metrological module

Marking CE M-XX* 0102

DN 40 ... 150: DE-09-MI001-PTB 010

DN 200 ... 300: DE-15-MI001-PTB 014

* year of production

MeiStream

Bulkmeter for cold potable water DN 40 ... 300

METROLOGICAL DATA ACC. TO MANUFACTURERS VALUES

	Size	DN	40	50	65	80	100
Q_s	Max. Peak Flow	m ³ /h	60	90	120	200	300
Q_3'	Continuous Flow	m ³ /h	40	50	70	120	230
Q_{2h}	Transitional Flowrate horizontal	m ³ /h	0.32	0.4	0.63	0.51	0.81
Q_{1h}'	Minimum Flow horizontal	m ³ /h	0.2	0.15	0.2	0.2	0.3
Q_{2v}	Transitional Flowrate vertical	m ³ /h	0.4	0.51	0.81	0.8	1.28
Q_{1v}'	Minimum Flow vertical	m ³ /h	0.25	0.28	0.4	0.5	0.5
	Starting Flow	m ³ /h	0.05	0.05	0.07	0.1	0.11

	Size	DN	125	150	200	250	300
Q_s	Max. Peak Flow	m ³ /h	350	600	1200	1600	2000
Q_3'	Continuous Flow	m ³ /h	250	450	800	1250	1400
Q_{2h}	Transitional Flowrate horizontal	m ³ /h	1.02	1.6	4.0	6.3	16.0
Q_{1h}'	Minimum Flow horizontal	m ³ /h	0.5	0.8	2.0	3.5	9.0
Q_{2v}	Transitional Flowrate vertical	m ³ /h	1.6	3.2	4.0	10.1	25.4
Q_{1v}'	Minimum Flow vertical	m ³ /h	1	1.6	2.5	6.3	15.9
	Starting Flow	m ³ /h	0.15	0.3	1.5	3	8

METROLOGICAL DATA ACC. TO 2014/32/EU (MID)

	Size	DN	40	50	65	80	100
Q_4	Overload Flowrate acc. to MID	m ³ /h	31.25	50	78.75	125	200
Q_3	Permanent Flowrate acc. to MID	m ³ /h	25	40	63	100	160
Q_{2h}	Transitional Flowrate horizontal acc. to MID	m ³ /h	0.32	0.4	0.63	0.51	0.81
Q_{1h}	Minimum Flowrate horizontal acc. to MID	m ³ /h	0.2	0.25	0.39	0.32	0.51
Q_{2v}	Transitional Flowrate vertical acc. to MID	m ³ /h	0.635	0.64	1.0	1.28	1.6
Q_{1v}	Minimum Flowrate vertical acc. to MID	m ³ /h	0.4	0.4	0.63	0.8	1.0
Q_3/Q_1 h	Max. Ratio horizontal		125	160	160	315	315
Q_3/Q_1 v	Max. Ratio vertical		63	100	100	125	160
Q_3/Q_1	Standard Marking		63	100	100	100	100
Δp	Headloss at Q_3 acc. to ISO 4064-1:2017	bar	0.1	0.16	0.32	0.16	0.34

	Size	DN	125	150	200	250	300
Q_4	Overload Flowrate acc. to MID	m ³ /h	200	500	787.5	787.5	1250
Q_3	Permanent Flowrate acc. to MID	m ³ /h	160	400	630	630	1000
Q_{2h}	Transitional Flowrate horizontal acc. to MID	m ³ /h	1.02	1.6	4.03	8.06	25.4
Q_{1h}	Minimum Flowrate horizontal acc. to MID	m ³ /h	0.64	1	2.52	5.04	15.9
Q_{2v}	Transitional Flowrate vertical acc. to MID	m ³ /h	2.05	3.2	4.03	10.1	25.4
Q_{1v}	Minimum Flowrate vertical acc. to MID	m ³ /h	1.28	2	2.52	6.3	15.9
Q_3/Q_1 h	Max. Ratio horizontal		250	400	250	125	63
Q_3/Q_1 v	Max. Ratio vertical		125	200	250	100	63
Q_3/Q_1	Standard Marking		100	100	100	100	63
Δp	Headloss at Q_3 acc. to ISO 4064-1:2017	bar	0.19	0.27	0.11	0.07	0.08

MeiStream

Bulkmeter for cold potable water DN 40 ... 300

Typical Headloss Curve

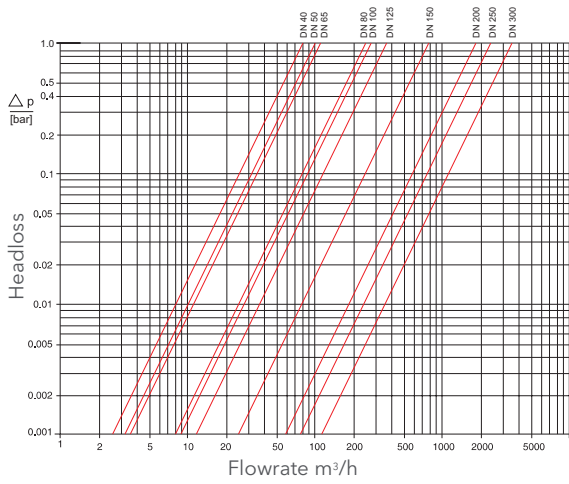

Typical Error Curve

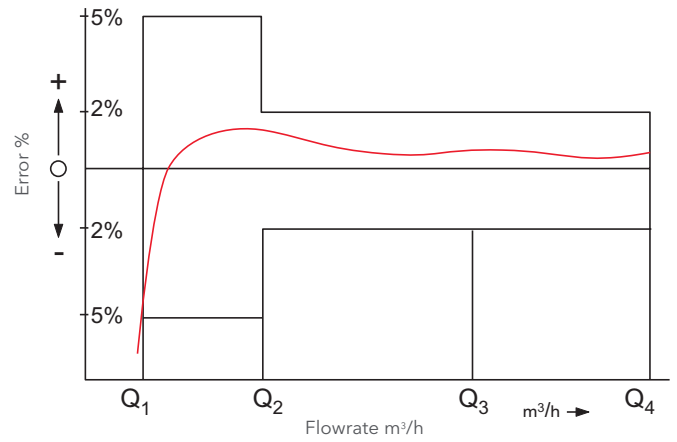

Dial

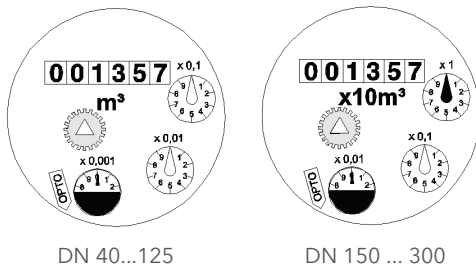

Nominal diameter DN	Smallest reading m ³	Max. reading m ³
40 ... 125	0.0005	999,999.999
150 ... 300	0.005	9,999,999.99

PULSE VALUES

Pulser Type	Pulse Value DN 40 ... 125	Pulse Value DN 150 ... 300
HRI-Mei (Leaflet see LS 8400)	0.01; 0.05; 0.1 or 1 m ³	0.1; 0.5; 1 or 10 m ³
OD 01 (Leaflet see LB 8300)	0.001 m ³	0.01 m ³
OD 03 (Leaflet see LB 8300)	0.01 m ³	0.1 m ³

INSTALLATION

Pipe	horizontal vertical	
Meter head	upwards sideways	

Dimension Picture

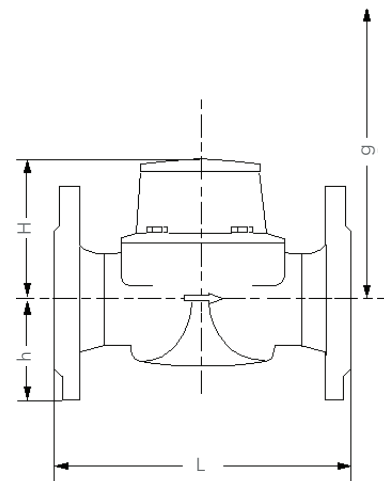

Installation Requirements

- Unrestricted straight pipe upstream 0 x DN
- No abrupt restrictions directly downstream of the meter

MeiStream

Bulkmeter for cold potable water DN 40 ... 300

Order Example

MeiStream, DN 50, T50, PN16	Type
Drilling EN 1092 PN16	Size
Length 270 mm	Max. medium temperature
mechanical register / m ³	Nominal pressure
with MID conformity	Drilling pattern
	Body length
	Register type / unit
	Approval standard

DIMENSIONS

Nominal Diameter	DN	40	50	50	50	65	65	80	80	80	80	
Overall length	L	mm	220	200	270	300	200	300	200	225	300	350
Height	H	mm	120	120	120	120	120	120	150	150	150	150
Height to pipe axis	h	mm	69	73	73	73	85	85	95	95	95	95
Dismantling height	g	mm	200	200	200	200	200	200	270	270	270	270

Nominal Diameter	DN	100	100	100	125	150	150	200	250	300	
Overall length	L	mm	250	350	360	250	300	500	350	450	500
Height	H	mm	150	150	150	160	177	177	214	238	264
Height to pipe axis	h	mm	105	105	105	118	135	135	162	194	226
Dismantling height	g	mm	270	270	270	280	356	356	449	474	499

WEIGHT PN 16

Nominal Diameter	DN	40	50	50	50	65	65	80	80	80	80	
Overall length	L	mm	220	200	270	300	200	300	200	225	300	350
Meter		kg	8.0	8.5	9.6	9.9	10.1	12.0	12.4	14.2	16.3	17.7
Metrological module		kg	1.5	1.5	1.5	1.5	1.5	1.5	3.2	3.2	3.2	3.2
Body		kg	6.5	7.0	8.1	8.4	8.6	10.5	9.2	11.0	13.1	14.5

Nominal Diameter	DN	100	100	100	125	150	150	200	250	300	
Overall length	L	mm	250	350	360	250	300	500	350	450	500
Meter		kg	17.0	20.0	20.2	20.7	35.9	44.2	56.9	79.4	103.8
Metrological module		kg	3.2	3.2	3.2	3.2	5.9	5.9	9.6	9.6	9.6
Body		kg	13.8	16.8	17.0	17.5	30.0	38.3	47.3	69.8	94.2

WEIGHT PN 40

Nominal Diameter	DN	50	50	65	80	80	100	100	150	150	
Overall length	L	mm	200	270	300	225	300	250	360	300	500
Meter		kg	9.7	10.7	13.1	17	18.6	20.4	22.9	44.6	52.9
Measuring insert		kg	1.7	1.7	1.7	4	4	4	4	9.3	9.3
Body		kg	8	9	11.4	14.6	14.6	16.4	18.9	35.3	43.6



Xylem.com | Sensus.com

UK & Ireland Inquiries | Sensus UK Systems Ltd. | +44 1256 372800 | SensusUK.Orders@xylem.com

International Inquiries | Sensus GmbH Hannover | Meineckestr. 10 | 30880 Laatzen | Germany | +49 5102 743177
info.int@xylem.com



©2020 Sensus. All products purchased and services performed are subject to Sensus' terms of sale, available at [sensus.com](https://www.sensus.com). Sensus reserves the right to modify these terms and conditions in its own discretion. The Sensus logo and other Sensus products or services referenced are registered trademarks of Sensus.

This document is for informational purposes only, and SENSUS MAKES NO EXPRESS WARRANTIES IN THIS DOCUMENT. FURTHERMORE, THERE ARE NO IMPLIED WARRANTIES, INCLUDING WITHOUT LIMITATION, WARRANTIES AS TO FITNESS FOR A PARTICULAR PURPOSE AND MERCHANTABILITY. ANY USE OF THE PRODUCTS THAT IS NOT SPECIFICALLY PERMITTED HEREIN IS PROHIBITED.