

Data sheet

Differential pressure controller (PN 16, 25, 40) AFP(-9) / VFG 2(1) – return and flow mounting, adjustable setting

Description



The controller has a control valve, an actuator with one control diaphragm and spring for differential pressure setting.

Further on two valve versions are available:

- VFG 2 with metallic sealing cone
- VFG 21 with soft sealing cone

Main data:

- DN 15-250
- k_{vs} 4.0-400 m³/h
- PN 16, 25, 40
- Setting range:
 - AFP: 0.05-0.35 bar / 0.1-0.7 bar / 0.15-1.5 bar
 - AFP-9: 0.5-3 bar / 1-6 bar
- Temperature:
 - Circulation water / glycolic water up to 30 %: 2 ... 150 / 200 °C
- Connections:
 - Flange

The controller is a self-acting differential pressure controller primarily for use in district heating systems. The controller closes on rising differential pressure.

Ordering

Example 1:
Differential pressure controller;
return mounting; DN 15; k_{vs} 4.0;
PN 16; metallic sealing; setting
range 0.15-1.5 bar; T_{max} 150 °C;
flange;

- 1x VFG 2 DN 15 valve
Code no: **065B2388**
- 1x AFP actuator
Code no: **003G1016**
- 2x Impulse tube set AF
Code no: **003G1391**

Products will be delivered separately.

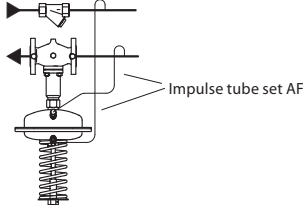

VFG 2 Valves (metallic sealing cone)

Picture	DN (mm)	k_{vs} (m ³ /h)	Connections	T_{max} (°C)	Code No.	T_{max} (°C)	Code No.	
					PN 16		PN 25	PN 40
	15	4.0	Flanges acc. to EN 1092-1	150	065B2388	200 ¹⁾	065B2401	065B2411
	20	6.3			065B2389		065B2402	065B2412
	25	8.0			065B2390		065B2403	065B2413
	32	16			065B2391		065B2404	065B2414
	40	20			065B2392		065B2405	065B2415
	50	32			065B2393		065B2406	065B2416
	65	50			065B2394		065B2407	065B2417
	80	80			065B2395		065B2408	065B2418
	100	125			065B2396		065B2409	065B2419
125	160	065B2397		065B2410	065B2420			
	150	280		150	150	065B2398	-	065B2421
	200	320				065B2399	-	065B2422
	250	400				065B2400	-	065B2423
	150	280		200 ¹⁾	200 ¹⁾	065B2424	-	On request
	200	320				065B2425	-	On request
	250	400	065B2426			-	On request	

¹⁾ at temperatures above 150 °C only with seal pots (see Accessories)

Ordering (continuous)

Example 2:
Differential pressure controller;
return mounting; DN 15; k_{vs} 4.0;
PN 25; metallic sealing; setting
range 0.15-1.5 bar; T_{max} 200 °C;
flange;

- 1x VFG 2 DN 15 valve
Code no: **065B2401**
- 1x AFP actuator
Code no: **003G1016**
- 2x Impulse tube set AF
Code no: **003G1391**
- 1x Seal pot V1
Code no: **003G1392**

Products will be delivered separately.

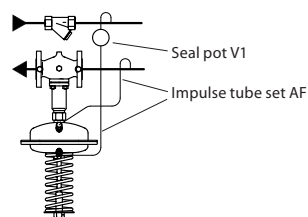

Example 3:
Differential pressure; flow
mounting; DN 15; k_{vs} 4.0;
PN 25; metallic sealing; setting
range 0.15-1.5 bar; T_{max} 200 °C;
flange;

- 1x VFG 2 DN 15 valve
Code no: **065B2401**
- 1x AFP actuator
Code no: **00G1016**
- 2x Impulse tube set AF
Code no: **003G1391**
- 1x Seal pot V1
Code no: **003G1392**

Products will be delivered separately.

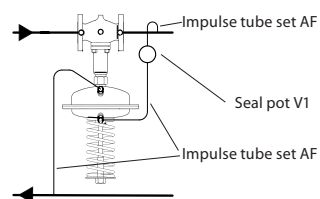

VFG 21 Valves (soft sealing cone)

Picture	DN (mm)	k_{vs} (m ³ /h)	Connections	T_{max} (°C)	Code No.
					PN 16
	15	4.0	Flanges acc. to EN 1092-1	150	065B2502
	20	6.3			065B2503
	25	8.0			065B2504
	32	16			065B2505
	40	20			065B2506
	50	32			065B2507
	65	50			065B2508
	80	80			065B2509
	100	125			065B2510
	125	160			065B2511
	150	280		150	065B2512
	200	320			065B2513
	250	400			065B2514

Note: other valves available on special request.

AFP / AFP-9 Actuators

Picture	Type	Δp setting range (bar)	for DN	Code No.
	AFP-9 ¹⁾	1-6	15-125	003G1014
		0.5-3		003G1015
	AFP	0.15-1.5	15-250	003G1016
		0.1-0.7		003G1017
		0.05-0.35		003G1018

¹⁾ actuator does not have excess pressure safety valve

Accessories

Picture	Type designation	Description	Connections	Code No.
	Impulse tube set AF	- 1x Copper tube $\varnothing 10 \times 1 \times 1500$ mm - 1 x compression fitting for imp. tube connection to pipe (G 1/4) - 2 x socket	-	003G1391
	Seal pot V1 ¹⁾	Capacity 1 liter; with compression fittings for imp. tube $\varnothing 10$	-	003G1392
	Seal pot V2 ¹⁾	Capacity 3 liter; with compression fittings for imp. tube $\varnothing 10$, for actuator size 630 cm ²	-	003G1403
	Compression fitting ²⁾	For impulse tube $\varnothing 10$ connections to controller	G 1/4	003G1468
	Combination piece KF3	For combination with pressure actuators. Electrical actuator connected on side (port B) only for ON/OFF function.	G 1 1/4 / 2x G 1 1/4	003G1441
	Combination piece KF2	For combination with thermostat - side connection to port B		003G1440
	Shut off valve	For impulse tube $\varnothing 10$	-	003G1401
	Throttle valve			065B2909

¹⁾ Seal pot has to be used on impulse tubes always when $T_{max} \geq 150$ °C

²⁾ Consist of a nipple, compression ring and nut

³⁾ Port A - for connection of any type of actuator

Ordering (continuous)

Service kits

Picture	Type designation	DN (mm)	k _{vs} (m ³ /h)	Code No.	
				for VFG 2	for VFG 21
	Valve insert	15	4.0	065B2796	065B2790
		20	6.3	065B2797	065B2791
		25	8	065B2798	065B2792
		32	16		
		40	20	065B2799	065B2793
		50	32		
		65	50	065B2800	065B2794
		80	80		
		100	125	065B2801	065B2795
		125	160		
150	280	065B2964	065B2966		
250	400	065B2965	-		
	Stuffing cone (with EPDM O-rings)			003G1464	

Technical data

Valve

Nominal diameter		DN	15	20	25	32	40	50	65	80	100	125	150	200	250
k _{vs} value		m ³ /h	4.0	6.3	8.0	16	20	32	50	80	125	160	280	320	400
Cavitation factor z			0.6	0.6	0.6	0.55	0.55	0.5	0.5	0.45	0.4	0.35	0.3	0.2	0.2
Leakage acc. to standard IEC 534 (% of k _{vs})		VFG 2	≤ 0.03										≤ 0.05		
		VFG 21	≤ 0.01												
Nominal pressure		PN	16, 25, 40												
Max. differential pressure		PN 16	16								15	12	10		
		PN 25, 40	20												
Media		Circulation water / glycolic water up to 30 %													
Media pH		Min. 7, max. 10													
Media temperature		VFG 2	2 ... 150 / 2 ... 200 ¹⁾										2 ... 150 (200 ²⁾)		
		VFG 21	2 ... 150												
Connections		Flange													
Materials															
Valve body		PN 16	Grey cast iron EN-GJL-250 (GG-25)												
		PN 25	Ductile iron EN-GJS-400(GGG-40.3)												
		PN 40	Cast steel GP240GH (GS-C 25)												
Valve seat		Stainless steel, mat. No. 1.4021											Stainless steel, mat. No. 1.4313		
Valve cone		Stainless steel, mat. No. 1.4404											Stainless steel, mat. No. 1.4021		
Sealing		VFG 2	Metal												
		VFG 21	EPDM												
Pressure relieve system		Bellows (Stainless steel, mat. No. 1.4571)											Diaphragm (EPDM)		

¹⁾ at temperatures above 150 °C only with seal pots (see Accessories)

²⁾ on request

Actuators

Type		AFP-9 ¹⁾		AFP		
Actuator size	cm ²	80		250		630
Max. operating pressure	bar	25		25		16
Diff. pressure setting ranges and spring colours	bar	red	yellow	red	yellow	yellow
		1-6	0.5-3	0.15-1.5	0.1-0.7	0.05-0.35
Materials						
Actuator housing		Steel, mat. No. 1.0338, zinc plated				
Control diaphragm		EPDM (Rolling; fibre enforced)				

¹⁾ Actuator does not have excess pressure safety valve

Application principles

– Return mounting

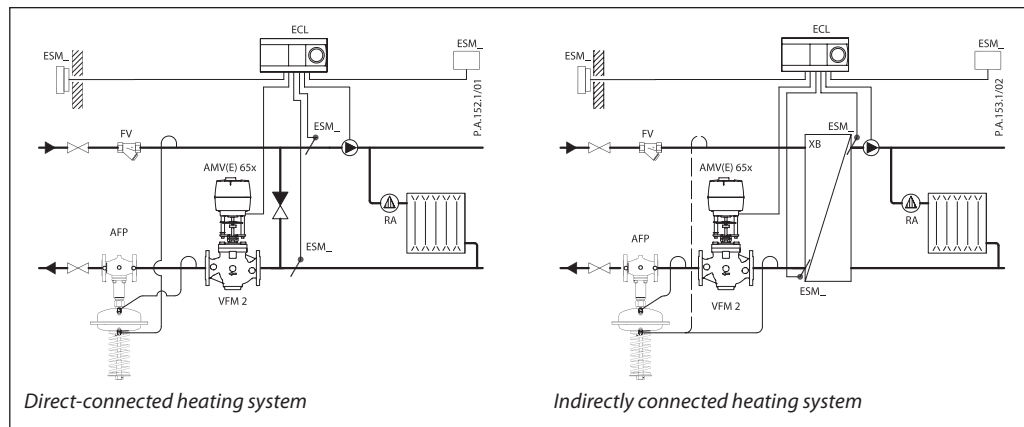

– Flow mounting

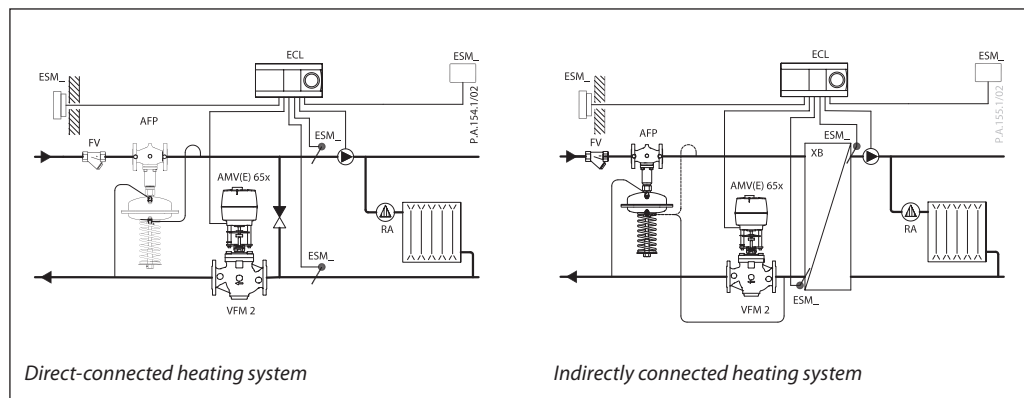

Combinations

Example
 Differential pressure and temperature controller
 AFP / AFT06 / VFG 2; DN 15; PN 16;
 k_{vs} 4.0; T_{max} 150 °C; 0.15-1.5 bar;
 range 20 ... 90 °C;

- 1x VFG 2 DN 15 valve
Code no: **065B2388**
- 1x AFP actuator
Code no: **003G1016**
- 1x AFT06 thermostat
Code no: **065-4391**
- 1x Combination piece KF2
Code no: **003G1398**
- 2x Impulse tube set AF
Code no: **003G1391**

Parts will be delivered separately.

Note:
 For AFT 06 and STFW thermostats
 data see relevant data sheets

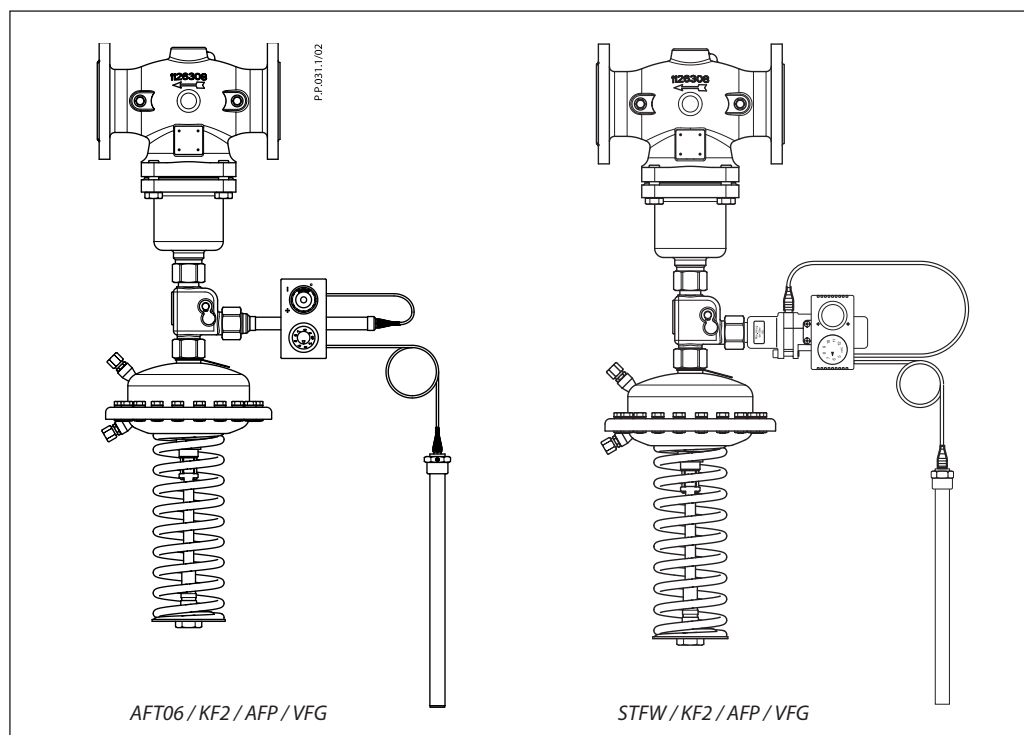

Installation position

DN 15-80 $T_{max} \leq 120\text{ }^{\circ}\text{C}$

DN 15-80 $T_{max} > 120\text{ }^{\circ}\text{C}$; DN 100-250

The controllers can be installed in any position.

The controllers can be installed in horizontal pipes only, with a pressure actuator oriented downwards.

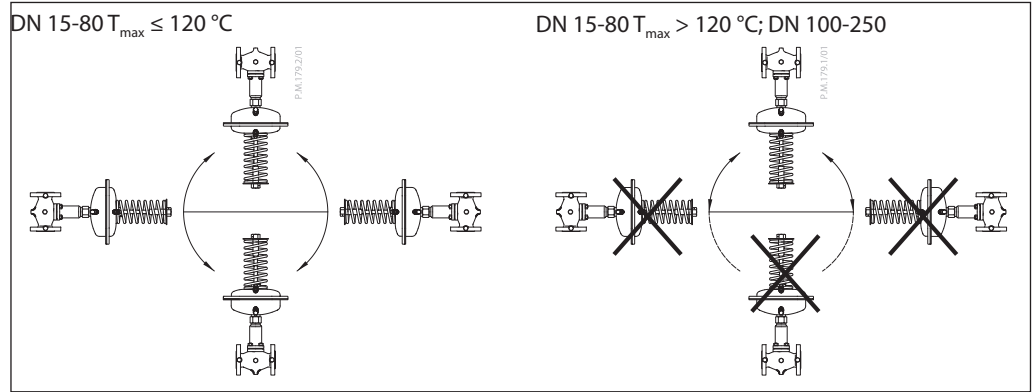

Pressure temperature diagram

Working area is below P-T line and it ends at T_{max} for each valve

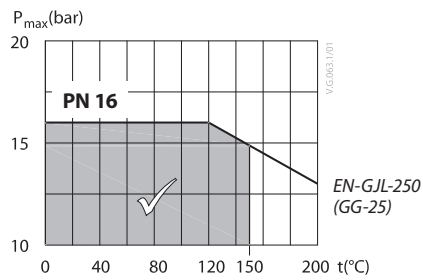

Maximum allowed operating pressure as a function of media temperature (according to EN 1092-2)

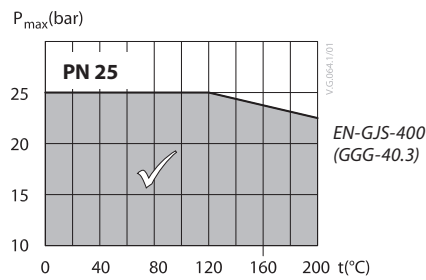

Maximum allowed operating pressure as a function of media temperature (according to EN 1092-2)

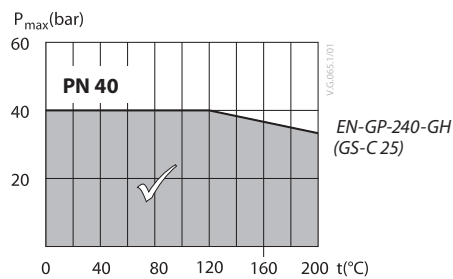

Maximum allowed operating pressure as a function of media temperature (according to EN 1092-1)

Sizing

– Directly connected heating system

Example 1

Motorised control valve (MCV) for mixing circuit in direct-connected heating system requires differential pressure of 0.3 bar (30 kPa).

Given data:

- $Q_{max} = 2.2 \text{ m}^3/\text{h}$ (1200 l/h)
- $\Delta p_{min} = 0.7 \text{ bar}$ (70 kPa)
- * $\Delta p_{circuit} = 0.1 \text{ bar}$ (10 kPa)
- $\Delta p_{MCV} = 0.3 \text{ bar}$ (30 kPa) selected

*Remark

$\Delta p_{circuit}$ corresponds to the required pump pressure in the heating circuit and is not to be considered when sizing the AFP.

The differential pressure set value is:

$$\Delta p_{set \text{ value}} = \Delta p_{MCV}$$

$$\Delta p_{set \text{ value}} = 0.3 \text{ bar} (30 \text{ kPa})$$

The total pressure loss across the controller is:

$$\Delta p_{AFP} = \Delta p_{min} - \Delta p_{MCV} = 0.7 - 0.3$$

$$\Delta p_{AFP} = 0.4 \text{ bar} (40 \text{ kPa})$$

Possible pipe pressure losses in tubes, shut-off fittings, heatmeters, etc. are not included.

k_v value is calculated according to formula:

$$k_v = \frac{Q_{max}}{\sqrt{\Delta p_{AFP}}} = \frac{2,2}{\sqrt{0,4}}$$

$$k_v = 3.5 \text{ m}^3/\text{h}$$

Solution:

The example selects AFP DN 15, k_{vs} value 4.0, with differential pressure setting range 0.15-1.5 bar.

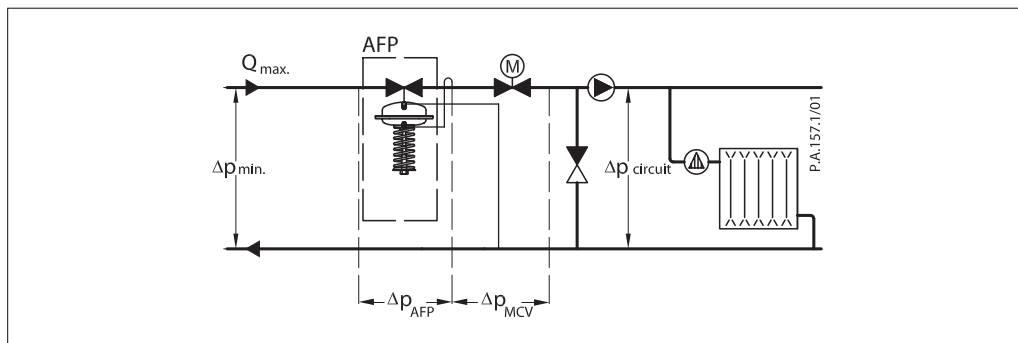
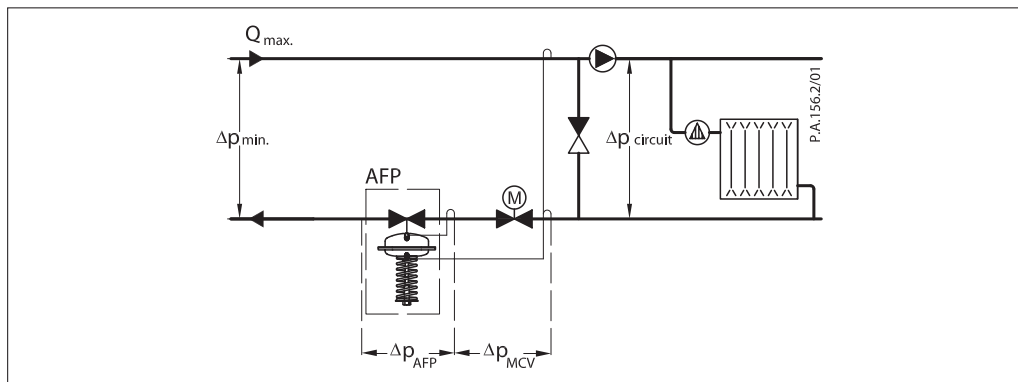

Sizing (continuous)

- Indirectly connected heating system

Example 2

Motorised control valve (MCV) for indirectly connected heating system requires differential pressure of 0.5 (50 kPa) bar.

Given data:

- $Q_{max} = 2.4 \text{ m}^3/\text{h}$ (1250 l/h)
- $\Delta p_{min} = 1.0 \text{ bar}$ (100 kPa)
- $\Delta p_{exchanger} = 0.05 \text{ bar}$ (5 kPa)
- $\Delta p_{MCV} = 0.4 \text{ bar}$ (40 kPa) selected

The differential pressure set value is:

$$\Delta p_{set\ value} = \Delta p_{exchanger} + \Delta p_{MCV} = 0.05 + 0.4$$

$$\Delta p_{set\ value} = 0.45 \text{ bar} \text{ (45 kPa)}$$

The total pressure loss across the controller is:

$$\Delta p_{AFP} = \Delta p_{min} - \Delta p_{exchanger} - \Delta p_{MCV} = 1.0 - 0.05 - 0.4$$

$$\Delta p_{AFP} = 0.55 \text{ bar} \text{ (55 kPa)}$$

Possible pipe pressure losses in tubes, shut-off fittings, heatmeters, etc. are not included.

k_v value is calculated according to formula:

$$k_v = \frac{Q_{max}}{\sqrt{\Delta p_{AFP}}} = \frac{2,4}{\sqrt{0,55}}$$

$$k_v = 3.2 \text{ m}^3/\text{h}$$

Solution:

The example selects AFP DN 15, k_{vS} value 4.0, with differential pressure setting range 0.15-1.5 bar.

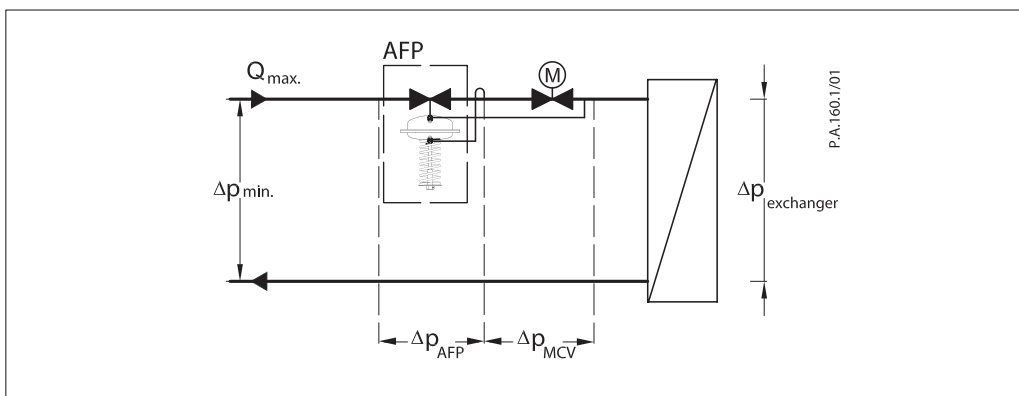
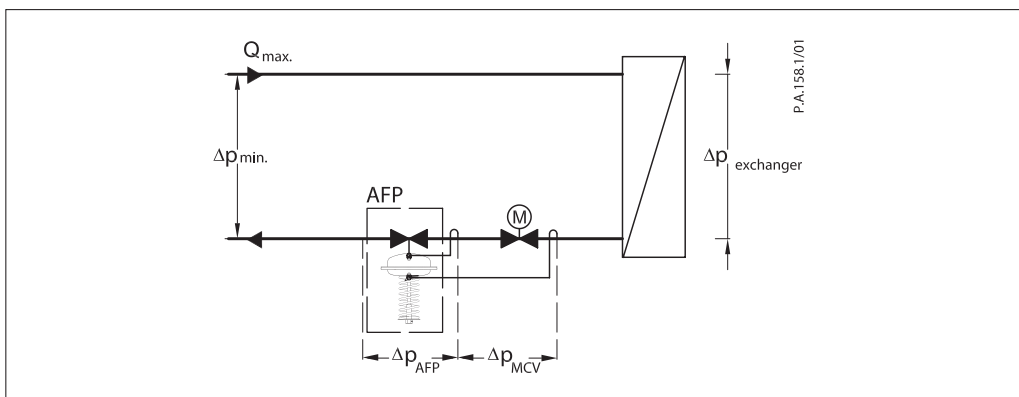

Design

1. Valve body
2. Cover
3. Valve seat
4. Valve insert
5. Pressure relieved valve cone
6. Valve stem
7. Bellows for pressure relief of valve cone
8. Actuator
9. Diaphragm for pressure relief of valve cone
10. Control diaphragm for differential pressure control
11. Excess pressure safety valve
12. Setting spring for diff. pressure control
13. Adjuster for diff. pressure setting, prepared for sealing
14. Stuffing cone
15. Union nut
16. Compression fitting for impulse tube
17. Upper casing of diaphragm
18. Lower casing of diaphragm
19. Valve body extension
20. Shut off valve for water filling
21. Closing plug

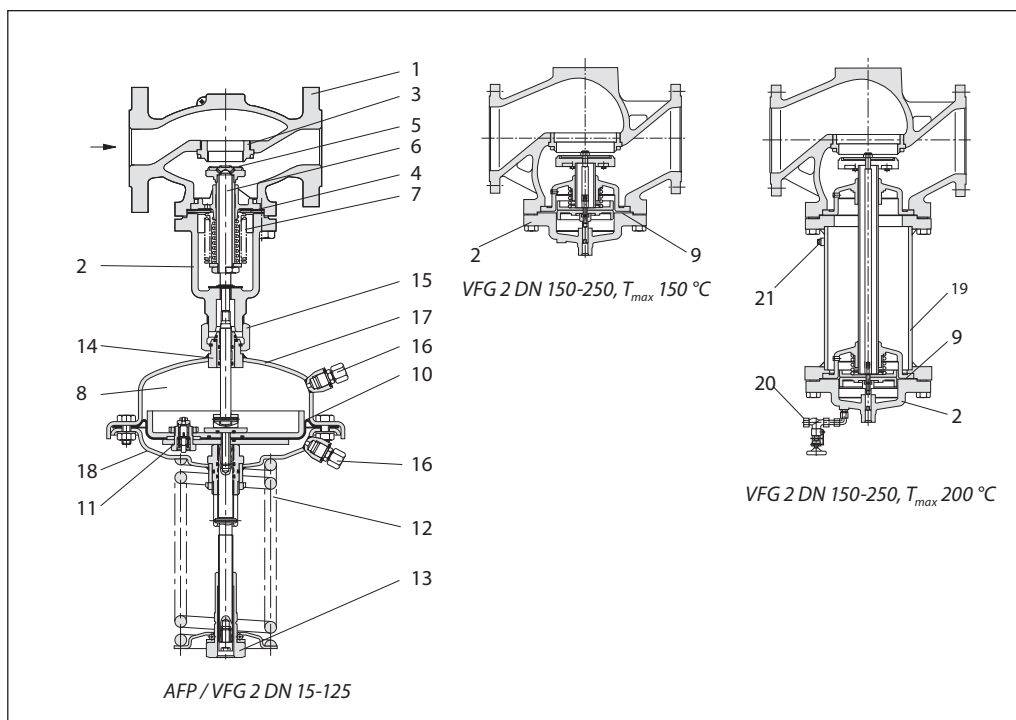

Function

Pressure changes from flow and return pipes are being transferred through the impulse tubes to the actuator chambers and act on control diaphragm for diff. pressure control. The diff. pressure is controlled by means of setting spring for diff. pressure control. Control valve closes on rising differential pressure and opens on falling differential pressure to maintain constant differential pressure.

Controller is equipped with excess pressure safety valve (not AFP-9), which protects control diaphragm for diff. pressure control from too high differential pressure.

Settings

Differential pressure setting
 Differential pressure setting is being done by the adjustment of the setting spring for diff. pressure control. The adjustment can be done by means of spring for diff. pressure setting and/or pressure indicators.

Dimensions

VFG DN 15-125

VFG DN 150-250

VFG DN 150-250
with valve body extension up to 200 °C

VFG 2, VFG 21 Valves

DN		15	20	25	32	40	50	65	80	100	125	150	200	250
L		130	150	160	180	200	230	290	310	350	400	480	600	730
B		213	213	239	239	241	241	276	276	381	381	326	354	401
H		267	267	304	304	323	323	370	370	505	505	505	591	661
Weight	PN 16 / 25	7.5	8.5	10	12	15	18	27.5	30	58	68	115	185	323
	PN 40							30	32.5	60.5	69	141	253	333
B ₁												620	852	1199
H ₁												799	1089	1459
Weight (valve with body extension)	PN 16 / 25											154	301	469
	PN 40											179	336	505

AFP Actuator

Actuator size	cm ²	80	250	630
A	mm	172	263	380
H	mm	430	470	520
Weight	kg	7.5	13	28

Seal pot V1

Seal pot V2

Shut off valve

Comb. piece KF2, KF3

Compression fitting



Danfoss A/S

Heating Segment • heating.danfoss.com • +45 7488 2222 • E-Mail: heating@danfoss.com

Danfoss can accept no responsibility for possible errors in catalogues, brochures and other printed material. Danfoss reserves the right to alter its products without notice. This also applies to products already on order provided that such alterations can be made without subsequential changes being necessary in specifications already agreed. All trademarks in this material are property of the respective companies. Danfoss and all Danfoss logotypes are trademarks of Danfoss A/S. All rights reserved.
