

T 3226 EN

Type 45-6 Differential Pressure Regulator ¹⁾

Series 45 Self-operated Regulators



Application

Differential pressure regulator for extended piping systems and industrial applications for installation in a bypass or a short-circuit pipe

Differential pressure set points from **0.1 to 4 bar** · Valve sizes **DN 15 to 50** · Pressure rating **PN 25** · Suitable for liquids up to **150 °C** as well as nitrogen and air up to **150 °C** ²⁾

The valve **opens** when the differential pressure **rises**.

The regulators consist of a globe valve and an actuator. They regulate the differential pressure to the set point adjusted at the actuator.

Special features

- Low-maintenance proportional regulators requiring no auxiliary energy
- Suitable for water and other non-flammable liquids or gases, provided these do not cause the materials used to corrode
- Single-seated valve with balanced plug
- Regulator ready to use; control lines do not need to be routed on installation
- Exchangeable operating diaphragm
- Low overall height achieved by using a compact spring assembly

Versions

Differential pressure regulators for installation in a bypass pipe or short-circuit pipe (see Fig. 2)

Valves DN 15 to 50 with connection nuts and welding ends

Valves in DN 32, 40, and 50 also with flanged bodies made of spheroidal graphite iron

- With opening actuator and adjustable set point
- With attached control line for the upstream pressure
- Connection of downstream pressure through a hole in the valve body
- Balanced plug
- Adjustable set point within 0.1 to 4 bar range
- With rotary knob for set point adjustment and with scale division (DN 15 to 32 only, set point range 0.1 to 1 bar)

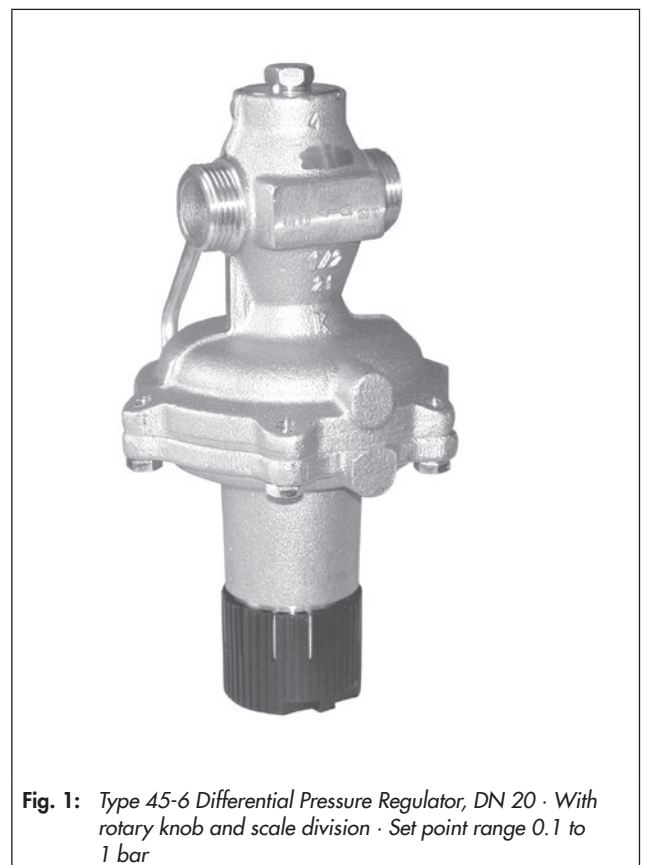

Fig. 1: Type 45-6 Differential Pressure Regulator, DN 20 · With rotary knob and scale division · Set point range 0.1 to 1 bar

Further versions

- Valves in DN 15 to 50 with threaded ends or screw-on flanges
- With internal parts made of FKM, e.g. for use with mineral oils · Other oils on request
- Special K_{VS} coefficient in DN 15

¹⁾ Date of manufacture: July 2005 or later

²⁾ Diaphragm and seals made of FKM

Principle of operation

The medium flows through the valve (1) as indicated by the arrow. The position of the valve plug (3) determines the differential pressure Δp over the cross-sectional area released between the plug and seat (2).

The differential pressure to be controlled is transferred to the operating diaphragm (6.1) where it is transformed into a positioning force. The pressure downstream of the valve is transmitted to the top diaphragm chamber (low-pressure chamber) of the actuator (6) through the body hole (11.1). The pressure upstream of the valve is transmitted through the attached control line (11) and acts on the high-pressure side of the diaphragm. The resulting positioning force moves the plug depending on the spring rate of the set point spring (8) and the setting at the set point adjuster (10).

The valve has a balanced plug to eliminate the forces at the valve plug caused by the differential pressure.

Installation

The regulator is suitable for installation into horizontal pipes as well as vertical pipes.

Regulators in DN 32 or larger must only be installed horizontal pipes (with the actuator facing down).

Installation conditions:

- The direction of flow must match the direction indicated by the arrow on the body
- If possible, install a strainer (e.g. SAMSON Type 1 NI) upstream of the valve.

Further details can be found in

► EB 3226.

Sample applications

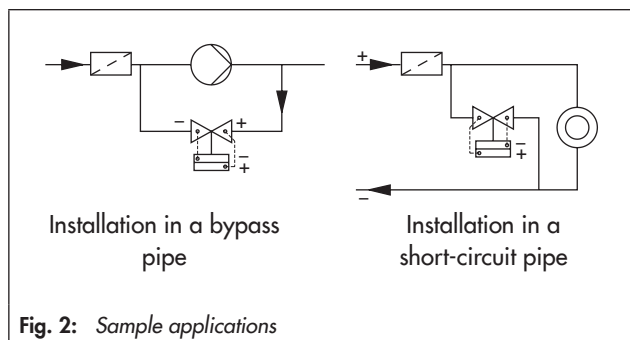

Fig. 2: Sample applications

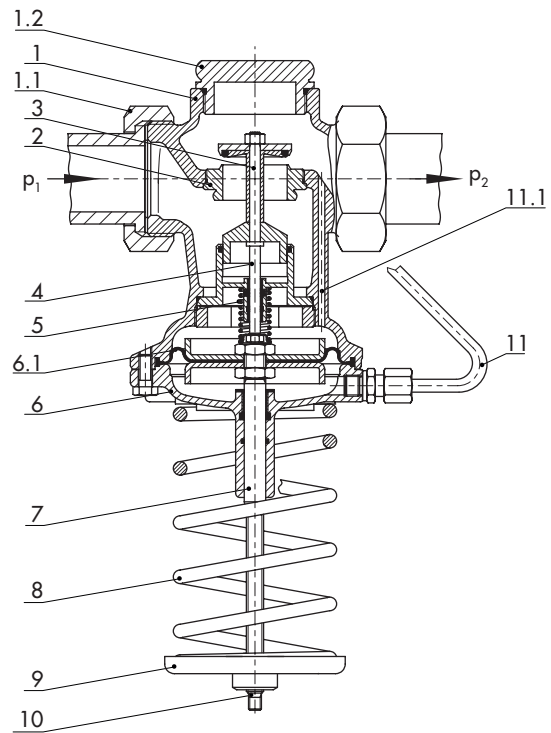
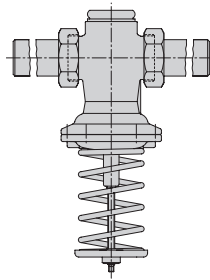

Fig. 3: Type 45-6, DN 15 to 50 · With connection nuts and welding ends

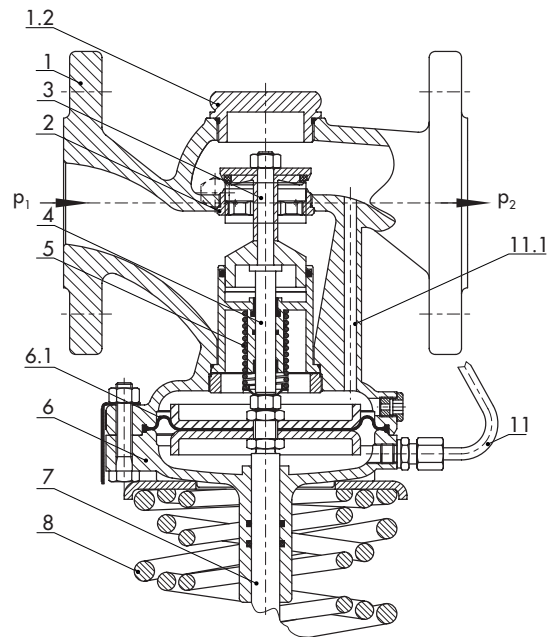

Fig. 4: Type 45-6, DN 32 to 50 · With flanged body valve

1	Valve body	6.1	Operating diaphragm
1.1	Connection nut with seal and welding end	7	Actuator stem
1.2	Stopper	8	Set point spring (assembly)
2	Seat	9	Spring plate
3	Plug (balanced)	10	Set point adjuster
4	Plug stem	11	Control line
5	Valve spring	11.1	Bohrung
6	Actuator		

Note: actuator case and control line are turned into the plane of projection. The line is located in front of the body.

Table 1: Technical data

Valve size	DN 15	DN 20	DN 25	DN 32 ¹⁾	DN 40 ¹⁾	DN 50 ¹⁾
K _{VS} coefficient	Standard	4	6.3	8	12.5	20
	Special versions	1 · 2.5	-			
	Flanged body	-			12.5	20
x _{FZ} value	Standard	0.6		0.55	0.55	
	Flanged body	-			0.45	
Pressure rating	PN 25					
Max. permissible differential pressure Δp across the valve	20 bar				16 bar	
Max. permissible temperature	Liquids: 150 °C · Nitrogen and air: 150 °C ²⁾					
Compliance	CE · EAC					
Differential pressure set point ranges						
Continuously adjustable	0.1 to 1 bar ³⁾				0.2 to 1 bar	
	0.5 to 2 bar · 1 to 4 bar					

¹⁾ Additional version: Valve with flanged body made of spheroidal graphite iron

²⁾ Diaphragm and seals made of FKM

³⁾ Version with rotary knob and scale division

Table 2: Materials · Material numbers according to DIN EN

Body	Red brass CC491K/CC499K (Rg 5) · Spheroidal graphite iron EN-GJS-400-18-LT ¹⁾
Seat	Stainless steel 1.4305
Plug	Brass, resistant to dezincification, with EPDM soft seal ²⁾
Valve springs	Stainless steel 1.4310
Operating diaphragm	EPDM with fabric reinforcement ²⁾
Seals	EPDM ²⁾

¹⁾ Version only in DN 32, 40, and 50: valve with flanged body made of spheroidal graphite iron

²⁾ Special version, e.g. for mineral oils: FKM

Flow rate diagram for water

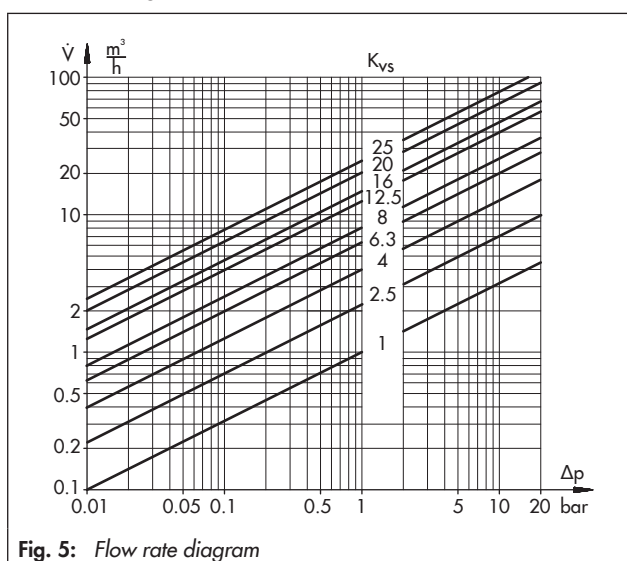

Fig. 5: Flow rate diagram

Ordering text

Type 45-6 Differential Pressure Regulator

DN ...

K_{VS} coefficient ...

Permissible temperature ... °C

With welding ends, threaded ends, flanges or flanged valve body in DN 32, 40, and 50

Set point range ... bar

Optionally, special version

Dimensional drawings

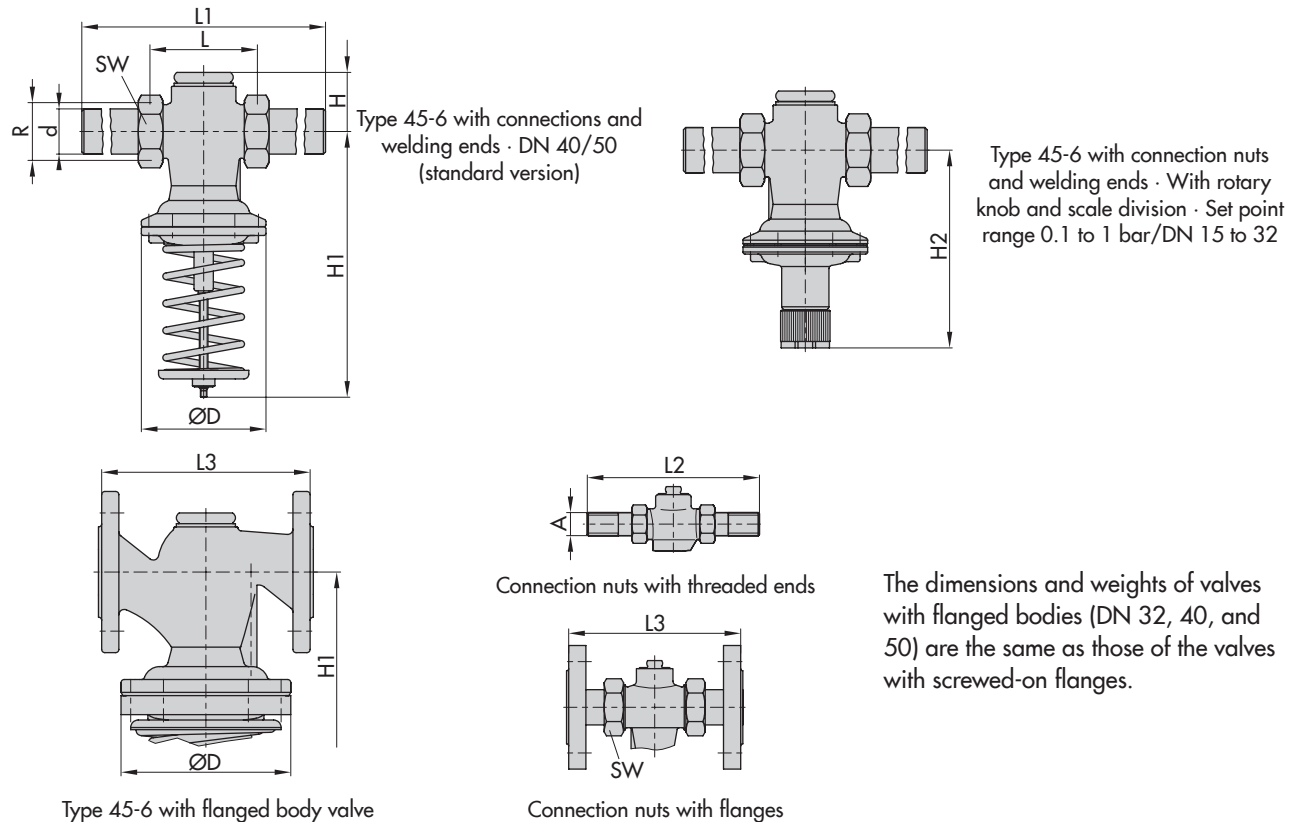

Table 3: Dimensions in mm · Standard version

Valve size DN	15	20	25	32 ¹⁾	40 ¹⁾	50 ¹⁾
Pipe Ø d	21.3	26.8	32.7	42	48	60
Connection R	G ¾	G 1	G 1¼	G 1¾	G 2	G 2½
Width across flats SW	30	36	46	59	65	82
L	65	70	75	100	110	130
H		40			58	
H1		230		250		380
H2		160		180		-
ØD			116			160

¹⁾ Additional version: valve with flanged body

Table 4: Dimensions in mm and weights in kg · Including connecting parts

Valve size DN	15	20	25	32	40	50
With welding ends						
L1	210	234	244	268	294	330
Weight	2.0	2.1	2.2	8.5	9.0	9.5
With threaded ends						
L2	129	144	159	180	196	228
Male thread A	G ½	G ¾	G 1	G 1¼	G 1½	G 2
Weight	2.0	2.1	2.2	3.5	9.0	9.5
With flanges^{1) 2)} or with flanged body (DN 32 to 50)						
L3	130	150	160	180	200	230
Weight	3.4	4.1	4.7	6.7	13.0	14.5

¹⁾ PN 16/25

²⁾ Flanges are already mounted on valves in DN 40 and 50.