

TA-MC100



Actuators

High performance proportional actuator – 1000 N

TA-MC100

High performance proportional actuators with automatic stroke adaptation which provide accurate modulating or 3-point control when used together with 2-way and 3-way control valves from IMI Hydronic Engineering.

Key features

> Easy commissioning

Automatic measurement and adaptation to the valve lift as well as load-dependent end position switch-off helps to reduce commissioning time and protect the valve and actuator from overloading.

> Easy troubleshooting

Protected hand drive for a safe manual operation enables easy troubleshooting.

> Ease of service

The actuator housing cover is easy to remove. Parameters can easily be changed on site.



Technical description

Functions:

Modulating or 3-point control.

Supply voltage:

24 VAC/VDC* $\pm 10\%$
 230 VAC $+6\%/-10\%$
 115 VAC $+6\%/-10\%$
 Frequency 50-60 Hz $\pm 5\%$
 *) DC – Direct current flat voltage.

Power consumption:

24 V: 6 VA
 230 V: 12 VA
 115 V: 12 VA

Input signal:

0(2)-10 VDC, $R_i \sim 77 \text{ k}\Omega$
 0(4)-20 mA, $R_i \sim 510 \Omega$.
 Signal direction and starting point adjustable by micro switches.
 3-point control.

Output signal:

0-10 VDC, max. 8 mA, min. 1,2 k Ω .

Hysteresis:

0,15 or 0,5 V

Resolution:

Electric: 0,04 VDC
 Mechanical: 0,095 mm

Control speed:

1.9, 4, 9, 12 s/mm

Adjusting force:

1000 N

Operation mode:

S3-50% ED c/h 1200, EN 60034-1

End position switch-off:

Load-dependent

Temperature:

Max. ambient temperature: 60°C
 Min. ambient temperature: 0°C

Ingress protection:

IP54

Protection class:

(according to EN 60730)
 24 V: III
 230 V: II
 115 V: II

Stroke:

Max. 20 mm
 Automatic detection of the valve lift (stroke detection).

Electrical connection:

Actuator with screwed terminals.

Connection to valve:

Simple attachment to the valve by means of M8 screws.

For some valve types an adapter may be needed. Information on adapters included in valve datasheets.

Colour:

Black body and red cover.

Marking:

IMI TA, Article No, product name and technical specification.

Weight:

2,5 kg

Actuator variants:

- Position switch unit ¹⁾:
 2 switches (WE1/WE2), potential free, infinitely adjustable.
 Rated load: 8 A / 250 VAC, 8 A / 30 VDC.
 Switching voltage: max. 400 VAC, max. 125 VDC
- Ingress protection: IP65
- Output signal ¹⁾: X=0(4)...20 mA
- Adapter with coupling for external product

For variants and accessories please contact IMI Hydronic Engineering.

1) Position switch unit and output signal 0(4)...20 mA not in combination.

Function

Manual operation

Handwheel with automatic switch-off of the actuator.

Position indication

Indicators on the mounting rig.

Error detection

Automatic detection of broken control wire (for 2-10V / 4-20mA only).

Automatic detection of blocked valve.

Installation

Note: Read carefully the installation instruction of the actuator. Intended for indoor installation applications.

For outdoor installation applications please contact IMI Hydronic Engineering. In cooling systems, the pipe and valve must be insulated.

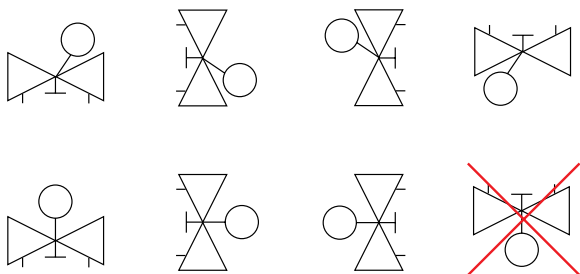

Note!

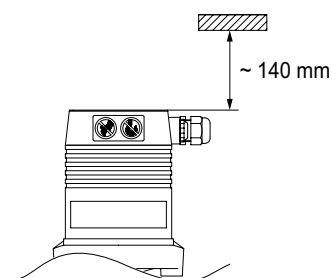

Connection diagram

24 VAC/VDC*

Modulating

0(2)-10V, 0(4)-20 mA

Standard design

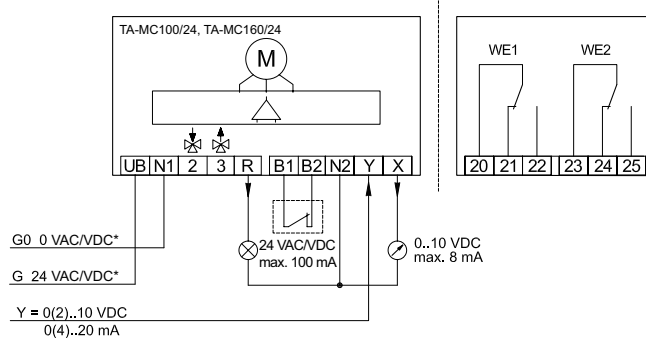

3-point

Standard design

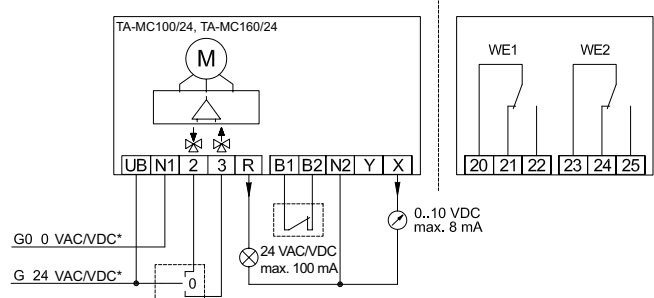

*) DC – Direct current flat voltage.

230 VAC

Modulating

0(2)-10V, 0(4)-20 mA

Standard design

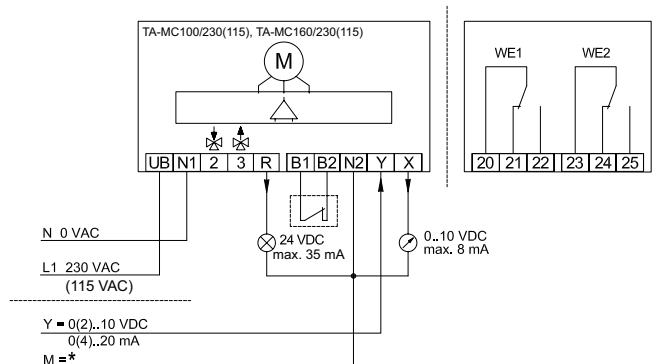

3-point

Standard design

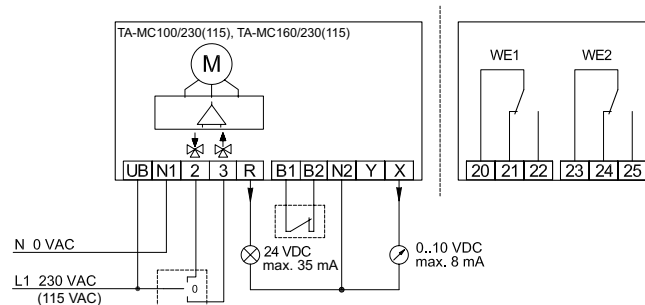

*) M = ground

Terminal	Description
UB, N1	Supply voltage
2	Control signal for extending the actuator spindle
3	Control signal for retracting the actuator spindle
R	Response signal during "manual" mode depending on the supply voltage: supply 24VAC: R = 24VAC max. 100mA supply 24VDC: R = 24VDC max. 100mA supply 230/115VAC: R = 24VDC max. 35mA
B1, B2	Connection of a potential free contact (e.g. for frost protection) - bridged if not used
Y	Input signal continuous mode
X	Output signal continuous mode
N2	Zero potential of signals X, Y and R - When the zero potentials of signals X, Y and R are identical to the zero potential of the supply voltage it is possible to bridge terminals N1 and N2. - If you run the actuator in continuous mode at 230 V (115 V) you will have to connect N2. - If you run the actuator in three-point mode at 230 V (115 V) you will have to connect N2 if you wish to use X or R at the same time.
WE1, WE2	Position switch units - see "Actuator variants"
20, 21, 22	Terminals of switching unit PS1
23, 24, 25	Terminals of switching unit PS2

For 24V/230V/115V 3-point control, the actuation direction can be changed by changing the supply lines of terminals 2 and 3 on the actuator.

Articles

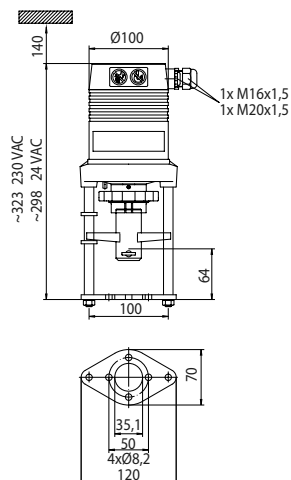

TA-MC100

Supply voltage	Input signal	EAN	Article No
24 VAC	0(2)-10 VDC, 0(4)-20 mA, 3-point	3831112511675	61 100-001
24 VDC*	0(2)-10 VDC, 0(4)-20 mA, 3-point		61 100-003
230 VAC	0(2)-10 VDC, 0(4)-20 mA, 3-point	3831112500235	61 100-002
115 VAC	0(2)-10 VDC, 0(4)-20 mA, 3-point		61 100-302

*) DC – Direct current flat voltage.

For some valve types an adapter may be needed. Information about adapters are included in the valve datasheets.

For IP65 version: Add "IP" after the Article No., example 61 100-001IP

Accessories

General actuator accessories

		EAN	Article No
ACA 71	Position Switch Unit (2 switches)	5902276894169	67 071-100
ACA 76	Output signal: 0(4)-20mA	5902276894183	67 076-100

Note: Position switch unit and output signal 0(4)-20 mA not in combination.

Stem heaters

TA-MC55, TA-MC55Y, TA-MC100, TA-MC160

Type	Supply voltage	EAN	Article No
ACV 13	24 VAC	3831112512108	68 013-015

