

# Operating Manual

## Linear actuators

MC55/24 • MC55/230 • MC55Y  
MC65/24 • MC65/230 • MC65Y



# Table of contents

<b>1 Safety</b> .....	<b>4</b>	<b>4 Assembly</b> .....	<b>11</b>
1.1 Proper use .....	4	4.1 Checking the scope of delivery .....	11
1.2 Information for the operator .....	4	4.2 Preparing assembly .....	11
1.3 Personnel.....	5	4.3 Mounting the linear actuator on the valve .....	12
1.4 Prior to starting work.....	5	4.4 Assembling/disassembling the cover .....	13
1.5 During operation .....	5	4.5 Electrical connection .....	14
1.6 Working environment.....	5	4.5.1 Controller independent circuit MC55Y and MC65Y .....	16
<b>2 Product Specification</b> .....	<b>6</b>	4.5.2 Remove push-fit PCB and transformer MC55/230 and MC65/230.....	17
2.1 Component parts .....	6	<b>5 Commissioning</b> .....	<b>18</b>
2.2 Operating modes .....	7	5.1 Operating parameters and jumper settings.....	19
2.2.1 Continuous mode MC55Y and MC65Y .....	7	5.2 Setting the input signal for MC55Y and MC65Y.....	19
2.2.2 Three-point mode MC55/24, MC55/230 and MC65/24, MC65/230 .....	7	5.3 Setting the actuating time.....	19
2.3 Functions .....	7	5.4 Setting the actuating direction.....	20
2.3.1 Binary signal / frost protection function MC55Y and MC65Y.....	7	5.5 Setting the limit position for MC55Y and MC65Y ...	21
2.3.2 Blockage detection .....	8	5.6 Commissioning.....	21
2.3.3 Wire break detection MC55Y and MC65Y....	8	<b>6 Operation</b> .....	<b>22</b>
2.3.4 Actuating time.....	8	6.1 Changing between manual and automatic mode...22	
2.3.5 Manual operation.....	8	<b>7 Maintenance, care and repairs</b> .....	<b>23</b>
2.4 Technical data .....	9	<b>8 Spare parts</b> .....	<b>23</b>
2.5 Type plate .....	10	<b>9 Decommissioning and disposal</b> .....	<b>23</b>
<b>3 Transportation &amp; Storage</b> .....	<b>10</b>	<b>10 Removal of faults</b> .....	<b>23</b>
		10.1 How to remedy faults .....	23
		10.2 Check list for breakdown.....	24

# 1 Safety

Read these Operating Instructions carefully particularly the following safety instructions prior to installation and operation.



**DANGER**

---

## **DANGER**

Directly threatening hazard leading to death or serious physical injuries.

---



**WARNING**

---

## **WARNING**

Potentially hazardous situation which may lead to death or serious physical injuries.

---



**CAUTION**

---

## **CAUTION**

Potentially hazardous situation which could lead to minor physical injuries. Indicates a hazard which may cause material damage.

---



**ATTENTION**

---

## **ATTENTION**

Potentially hazardous situation where the product or an object in its environment may get damaged.

---

**Hint:** Utilisation instructions and other useful information.

## 1.1 Proper use

Linear actuators MC55/24, MC55/230, MC55Y, MC65/24, MC65/230, MC65Y are controlled by three-point control or constant control. Linear actuators in the series described in these Operating Instructions are used for valve stroke adjustment. Concurrence of the above type designation with the linear actuator rating plate must be checked prior to starting any operations in order to guarantee utilisation in accordance with specification. The data on the rating plate is decisive for linear actuator technical data and mains power supply requirements.

Any utilisation for tasks other than the aforementioned usage in accordance with specification and operating with mains power supply ratios other than those permitted is not deemed to be utilisation in accordance with specification. The operator bears sole liability for the risk to persons and machine and other assets in the event of utilisation not in accordance with specification.

The intended use also includes the compliance with accident preventions, DIN VDE regulations and safe working practices for all measures described in these operating instructions in due consideration of prevailing rules.

## 1.2 Information for the operator

Always keep the Operating Instructions available at the linear actuator deployment site.

Observe the current health and safety, accident prevention and DIN VDE standards for installation, operation and maintenance.

Take into consideration any additional regional, local or in-house safety regulations.

Ensure that every person entrusted with one of the tasks specified in these Operating Instructions has read and understood these instructions.

### 1.3 Personnel

Only qualified personnel may work on these linear actuators or in their vicinity. Qualified persons are those persons entrusted with installation, assembly, commissioning and operation or maintenance of the linear actuators and possessing the appropriate qualifications for their activity. The necessary and prescribed qualifications include:

- Training / instruction or authorization to turn on /off circuits and appliances / systems according to EN 60204 (DIN VDE 0100 / 0113) and the standards of safety technology.
- Training or instruction according to the standards of the safety technology concerning care and use of adequate safety and work protection equipment.
- First Aid training.

Work in a safe manner and refrain from any working practice which endangers the safety of persons or damages the linear actuator or other assets in any way whatsoever.

### 1.4 Prior to starting work

Prior to starting any work, check that the type designations specified here concur with the data on the linear actuator rating plate.

Linear actuators MC55/24, MC55/230, MC55Y, MC65/24, MC65/230, MC65Y.

### 1.5 During operation

Safe operation is only possible if transportation, storage, installation, operation and maintenance are carried out safely and materially and professionally correctly.

#### **Transportation, installation and assembly**

Observe the general set-up and safety regulations for heating, ventilation, air-conditioning and pipework design. Use tools correctly. Wear the necessary personal and other safety equipment.

#### **Repairs and maintenance**

Ensure that qualified personnel switch off the linear actuator prior to maintenance or repair work in accordance with DIN VDE.

### 1.6 Working environment

Read the data concerning the working environment in the Technical Data.

## 2 Product Specification

The linear actuators control a stepper motor by means of a micro controller. The rotational movement of the stepper motor is converted into a linear movement by spur gears and a threaded spindle with spindle nut.

### 2.1 Component parts

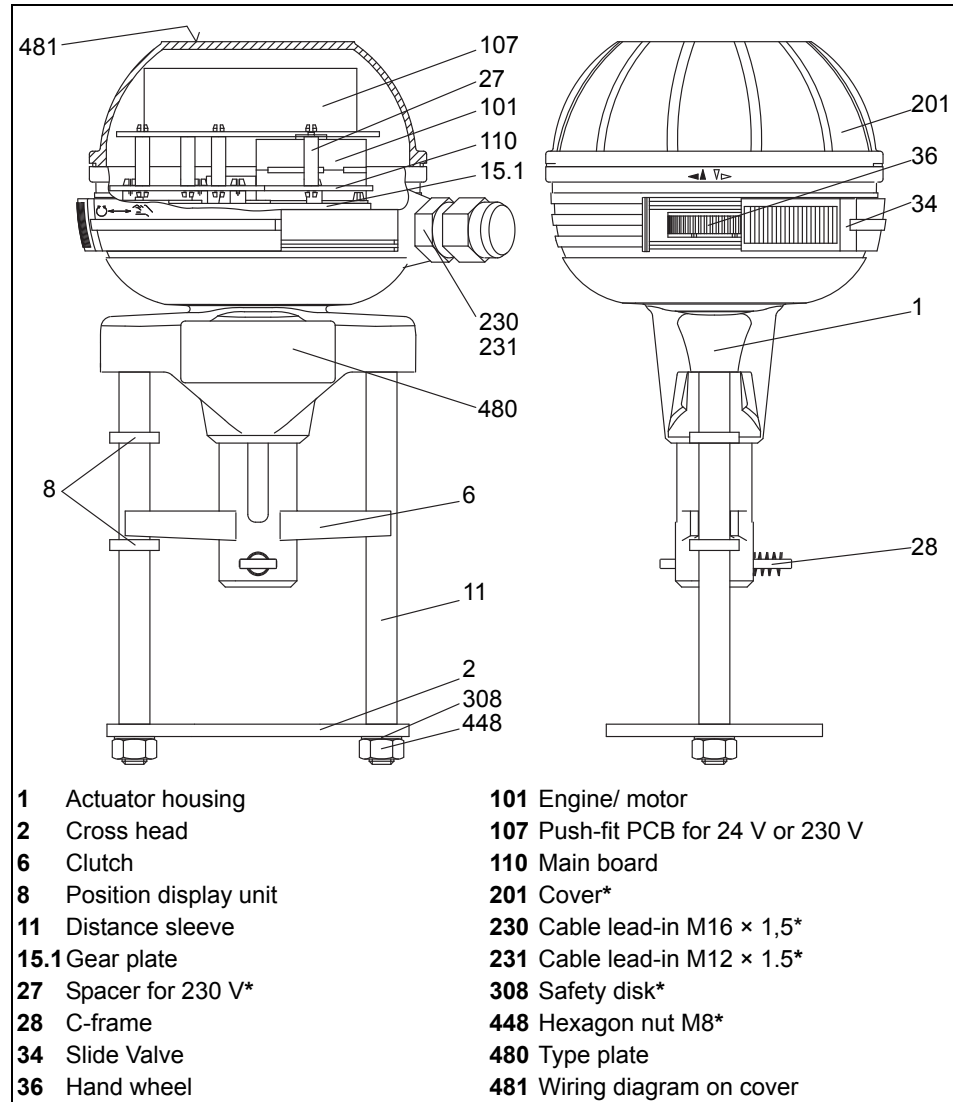

**diagram 1** Component part denominations

\* This component part is available as a spare part.

## 2.2 Operating modes

The linear actuator can be operated manually or automatically.

- In manual mode stroke is adjusted via the hand wheel.
- In automatic mode stroke is controlled electrically.

### 2.2.1 Continuous mode MC55Y and MC65Y

In continuous mode the system control presets the position of the linear actuator whilst inside the linear actuator the input signal (Y) of the system control is continuously compared with the output signal (X) of the linear actuator. In doing so the output signal depends on the position of the linear actuator (travel).

The linear actuator keeps moving until the input signal and the output signal match.

**Input signal (Y)** The input signal (Y) of the system control specifies the desired position for the linear actuator. It is applied in the form of an analogue signal to terminal Y.

Possible input signals:

- 0 ... 10 V DC / 2 ... 10 V DC
- 0 ... 20 mA / 4 ... 20 mA

**Output signal (X)** The output signal (X) determines the actual position of the linear actuator. It is applied to terminal X in the form of an analogue signal.

0% to 100% valve lift is put out as:

- 0 ... 10 V DC

### 2.2.2 Three-point mode MC55/24, MC55/230 and MC65/24, MC65/230

The direction of rotation is set via the control voltage at terminal 2 and terminal 3 on the main PCB:

- When the control voltage is applied to terminal 2, the spindle nut will be extended.
- When the control voltage is applied to terminal 3, the spindle nut will be retracted.

**Output signal (X)** The output signal (X) determines the actual position of the linear actuator. It is applied to terminal X in the form of an analogue signal.

0% to 100% valve lift is put out as:

- 0 ... 10 V DC

## 2.3 Functions

### 2.3.1 Binary signal / frost protection function MC55Y and MC65Y

The terminals B1 and B2 on the main PCB are bridged during normal operation. If the electric circuit between B1 and B2 is interrupted, the linear actuator will store the current position and afterwards move automatically to its limit position.

All other control signals will be ignored during this process.

The linear actuator will remain in limit position until the electric circuit between B1 and B2 has closed.

As soon as the electric circuit between B1 and B2 is closed, the desired value of the input signal will be started.

⇒ 5.5 *Setting the limit position for MC55Y and MC65Y* on page 21

### 2.3.2 Blockage detection

When the linear actuator is mechanically blocked the blockage detector will turn off the motor as soon as one of the two limit positions have been reached or a blockage occurs due to overload.

### 2.3.3 Wire break detection MC55Y and MC65Y

Wire break detection is only available for continuous mode with an input signal 2 ... 10 V DC and 4 ... 20 mA.

The linear actuator moves to the limit position set by jumper JP2 if the input signal drops below 1 V or 2 mA.

⇒ 5.5 *Setting the limit position for MC55Y and MC65Y* on page 21

### 2.3.4 Actuating time

The time required for the spindle nut to travel a defined distance is called actuating time. Actuating time is specified in s/mm. Jumper JP3 on the plug-in jumper wire is used to set the actuating time.

⇒ 5.3 *Setting the actuating time* on page 19

### 2.3.5 Manual operation

In manual mode it is possible to change the stroke without supply voltage.

- Motor and control electronics are turned off in manual mode to make hoisting movements of the control impossible.

⇒ 6.1 *Changing between manual and automatic mode* on page 22



## 2.4 Technical data

Type	MC55/24, MC55Y MC65/24, MC65Y	MC55/230 MC65/230
<b>Supply voltage:</b>	24 V AC $\pm$ 10% 24 V DC $\pm$ 10%	230 V AC + 6% -10% 115 V AC $\pm$ 10%
<b>Power consumption</b>	3,5 VA	7 VA
<b>Weight</b>	1.5 kg	1.5 kg
<b>Dimensions</b>	See technical data sheets	
<b>Stroke MC55</b>	max. 14 mm	max. 14 mm
<b>Stroke MC65</b>	max. 20 mm	max. 20 mm
<b>Frequency</b>	50/60 Hz $\pm$ 5%	50/60 Hz $\pm$ 5%
<b>Ambient temperature</b>	0 to +60°C	0 to +60°C
<b>Enclosure protection</b>	IP 54 IP 30 in manual mode	IP 54 IP 30 in manual mode
<b>Operating mode</b>	S3-50% ED	S3-50% ED
<b>Actuating time</b>	9 or 5 s/mm	9 or 5 s/mm
<b>Actuating force</b>	0.6 kN	0.6 kN
	During 24 V DC the specified actuating force can only be reached with the help of an aligned AC voltage.	

table 1 Technical data

Type	MC55/24, MC55/230 MC65/24, MC65/230	MC55Y MC65Y
<b>Input signal Y/ Resistance of load</b>	• Three-point	• 0 ... 10 V DC / 77 k $\Omega$ • 2 ... 10 V DC / 77 k $\Omega$ • 0 ... 20 mA / 510 $\Omega$ • 4 ... 20 mA / 510 $\Omega$
<b>Output signal X/ Load rating</b>	• 0 ... 10 V DC / resistance of load $\geq$ 1200 $\Omega$ , I <sub>max.</sub> 8 mA	
<b>Cable impedance between B1 and B2</b>	• max. 10 $\Omega$	

table 2 Technical data signals

#### 2.5 Type plate

The type plate is attached to the housing of the linear actuator.

It bears the type denomination, serial number (s/no) and date of manufacture (last four digits).

⇒ 2.1 *Component parts* on page 6

	
<b>MC55Y</b>	<b>08203017/01/0408</b>
AC 50/60 Hz	24V
max 3.5 VA	IP 54/30

**diagram 2** Example of type plate

## 3 Transportation & Storage



---

#### **Non-compliance with safety regulations may result in injury!**

- Wear the required personal and other safety equipment.
- 
- Avoid impacts, blows, vibrations etc. to the linear actuator.
  - Store the linear actuator (and, where appropriate, the entire controlling device) in a dry place.
  - Keep to the specified transport and storage temperatures between -20 to +65°C.

## 4 Assembly

Prior to assembling the linear actuator:

- ⇒ 4.1 *Checking the scope of delivery* on page 11
- ⇒ 4.2 *Preparing assembly* on page 11

The following sequence of operations is part of the linear actuator assembly:

- ⇒ 4.3 *Mounting the linear actuator on the valve* on page 12
- ⇒ 4.4 *Assembling/disassembling the cover* on page 13
- ⇒ 4.5 *Electrical connection* on page 14

### 4.1 Checking the scope of delivery

- 1 Check the packaging for damage.
- 2 Dispose of packaging in an environmentally friendly manner.
- 3 Check the delivered items against the delivery note in order to see whether the delivery is complete.
- 4 Report any missing or damaged products to the manufacturer.

### 4.2 Preparing assembly



#### A non-attached valve causes damage!

If you operate the linear actuator without valve, the spindle nut may fall off due to the missing stroke.

- Always operate the linear actuator with a valve attached.

- 1 Allow for about 140 mm space above the cover at the site of installation.
- 2 Check the working environment before assembling and commissioning the linear actuator:
- 3 Ensure that the valve is correctly fitted. For details please see assembly instructions for valve.
- 4 Determine the assembly position of the linear actuator. Do not arrange linear actuators in a hanging position.

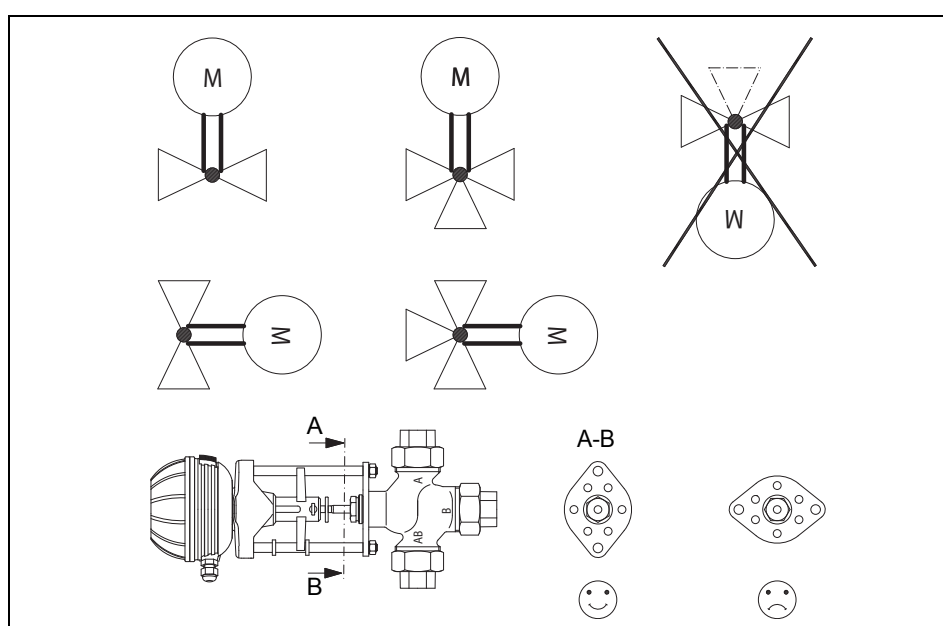

**diagram 3** Assembly positions for linear actuator and valve

### 4.3 Mounting the linear actuator on the valve

If the linear actuator and the valve are supplied separately you will have to mount the linear actuator on the valve.

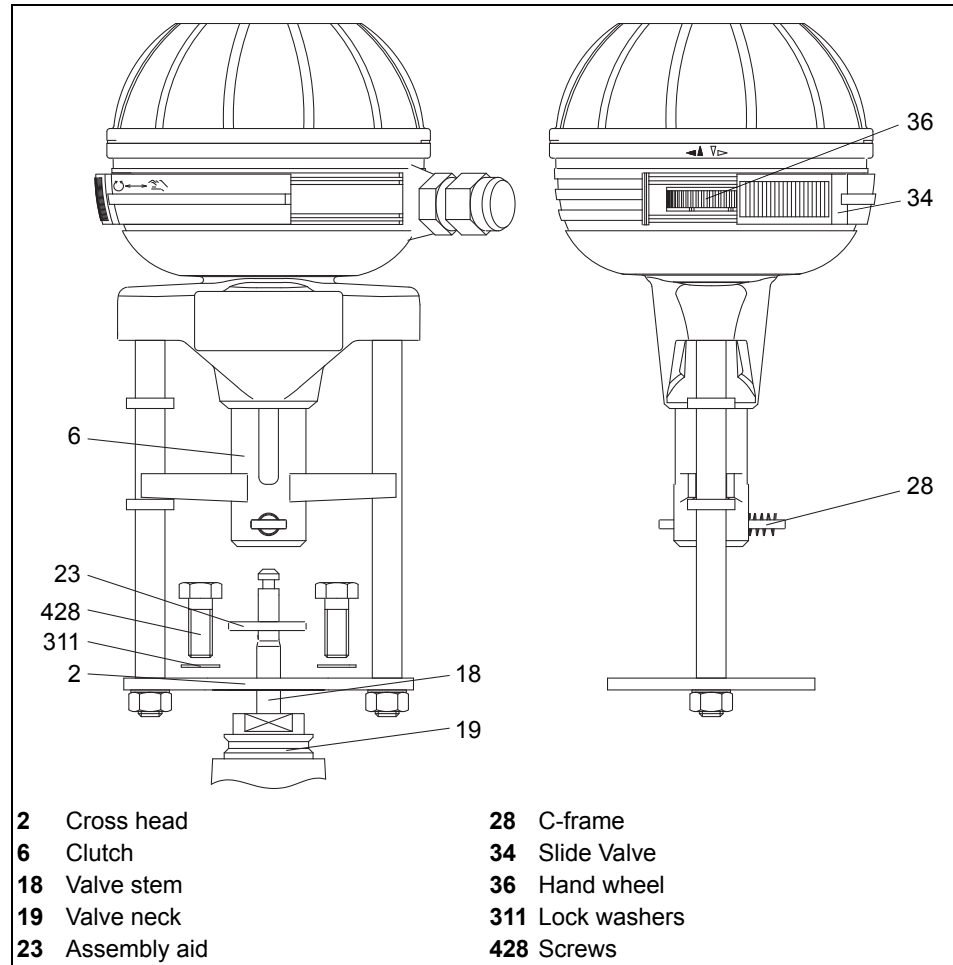

**diagram 4** Mounting the linear actuator on the valve

#### ■ How to assemble linear actuator:

- 1 Place actuator with crossbeam (2) on valve neck (19).  
⇒ *diagram 4* on page 12
- 2 Insert the C-frame (28) and, using a mounting aid, pull the valve stem upwards (18) (23) until the valve stem (18) locks inside the clutch (6).
- 3 Fix the crossbeam (2) of the actuator with the help of screws(428) spanner width 13 and lock washers (311) on the valve neck (19).

#### ■ How to disassemble the linear actuator

- 1 Follow the sequence of operation in reverse order.

## 4.4 Assembling/disassembling the cover



### Risk of injury from electric shock by live parts!

When the power supply is on there is a danger of electric shock due to live parts.

- Prior to commencing any work, ensure that the actuator is safely disconnected from the power supply system.
- Secure against unauthorised restarting.
- Remove the cover only momentarily.

### ■ How to remove the cover

- 1 Insert a screwdriver in the notch of the cover and lift the cover **(201)**.

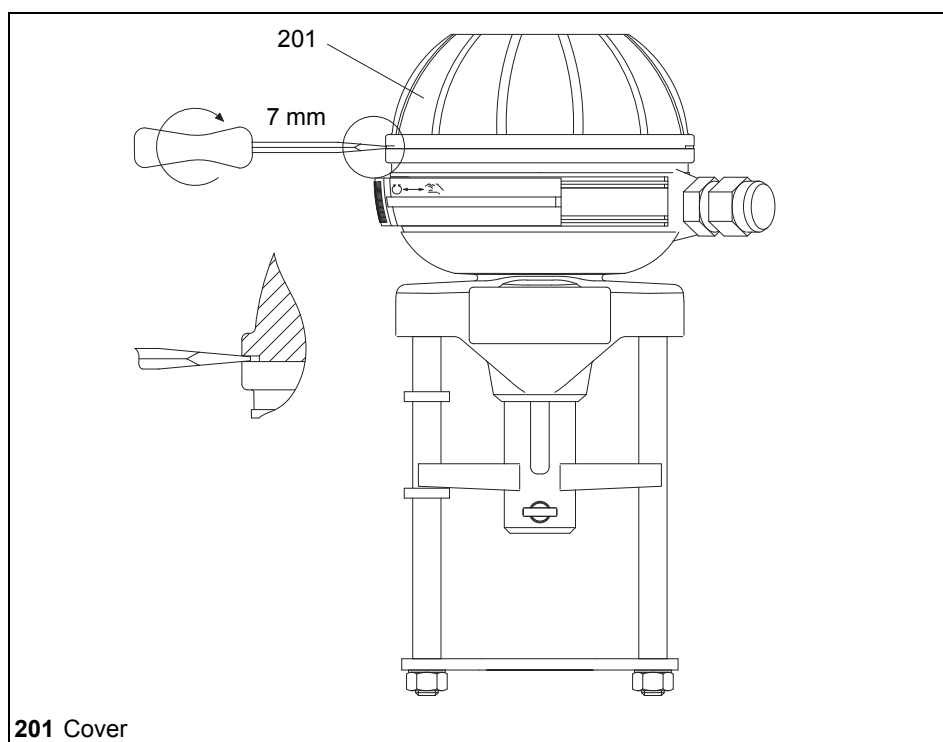

**diagram 5** Removing the cover

- 2 Remove the cover **(201)** carefully.

### ■ How to attach the cover

**Hint:** The cover may be mounted in any position.

- 1 Place the cover **(201)** on top and push it down to make it fit by applying moderate force.
- 2 Check the cover for correct fit to ensure air-tightness for the actuator housing.

## 4.5 Electrical connection



### Danger of life caused by incompetent staff!

Electrical connections carried out by unqualified staff may result in death, severe bodily injury or considerable material damage.

- Make sure that such all work is carried out by qualified staff.
- ⇒ 1.3 *Personnel* on page 5



### Risk of injury from electric shock by live parts!

When the supply voltage is turned on there is a risk of electric shock from live parts.

- Prior to commencing any work, ensure that the actuator is safely disconnected from the power supply system.
- Secure against unauthorised restarting.

#### ■ How to prepare the electric connection

- 1 Ensure that the supply voltage matches the specifications on the type plate of the linear actuator.
- 2 To avoid breakdown, construct the line diameter according to actuating performance and required line length.
- 3 Lay the mains for a supply voltage of > 48 V separate from the signal and control wires.

When laying cables in a joint cable duct, use shielded control wires.

- 4 Check the supply voltage.

If the required tolerance is not achieved by a power transformer you will have to use an AC voltage stabilizer.

⇒ 2.4 *Technical data* on page 9

#### ■ How to establish electrical connection

- 1 Remove the cover (201).  
⇒ *How to remove the cover* on page 13
- 2 Run the cable through the screw joint to the terminal strip.
- 3 Connect the power supply according to the wiring diagram.  
⇒ *diagram 6* on page 15

**Hint:** The wiring diagram (481) is on the cover (201).



### Malfunctions caused by incorrect zero potential!

If the electric power supply for the linear actuator is fed by transducing sensors with varying zero potentials this may result in incorrect automatic controller action.

- Ensure that the zero potential is properly applied.
- ⇒ *table 3* on page 15

- 4 Tighten the screw joints.

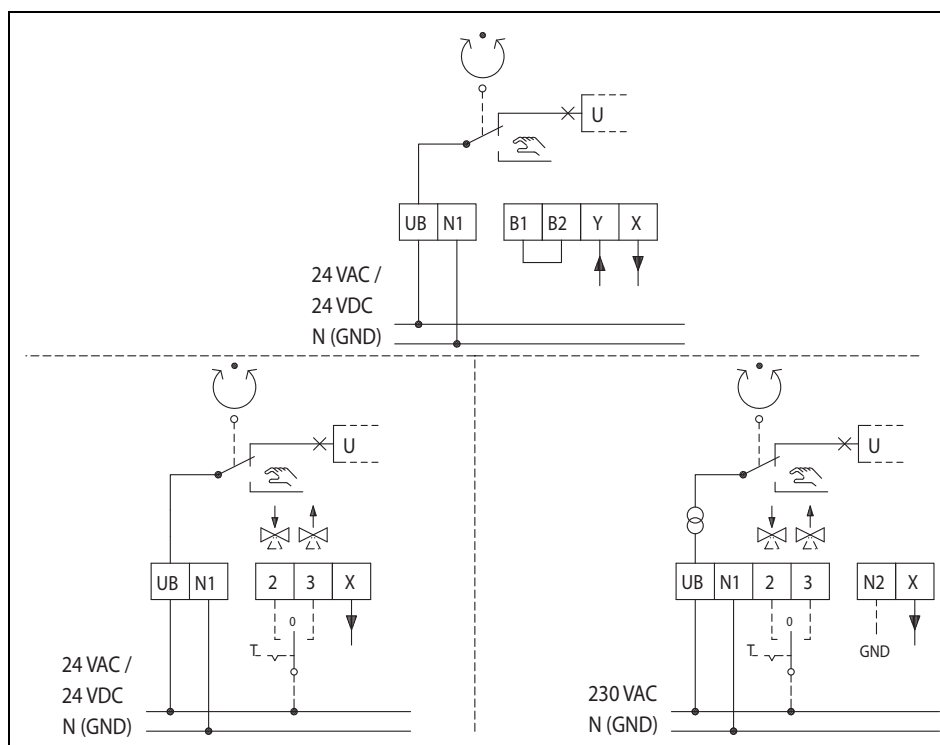

**diagram 6** Circuit diagram

Terminal	Description
<b>UB, N1</b>	Supply voltage:
<b>2</b>	Control voltage for downward movement during three-point mode
<b>3</b>	Control voltage for upward movement during three-point mode
<b>B1, B2</b>	Binary input / frost protection function
<b>N2</b>	Zero potential of signal X at 230 V AC <ul style="list-style-type: none"> <li>If you run the actuator in three-point mode at 230 V you will have to connect N2 before you can use X.</li> </ul>
<b>Y</b>	Input signal continuous mode
<b>X</b>	Output signal

**table 3** Key to wiring diagram

### 4.5.1 Controller independent circuit MC55Y and MC65Y

When working with 24 V supply voltage and 0 ... 10 V DC / 2 ... 10 V DC input signal you can switch the actuator controller-independently via a three-step toggle switch in the control cabinet.

#### ■ How to switch the actuator controller-independently

- 1 Run the supply voltage 24 V AC via a diode and a three-step toggle switch to terminal Y.

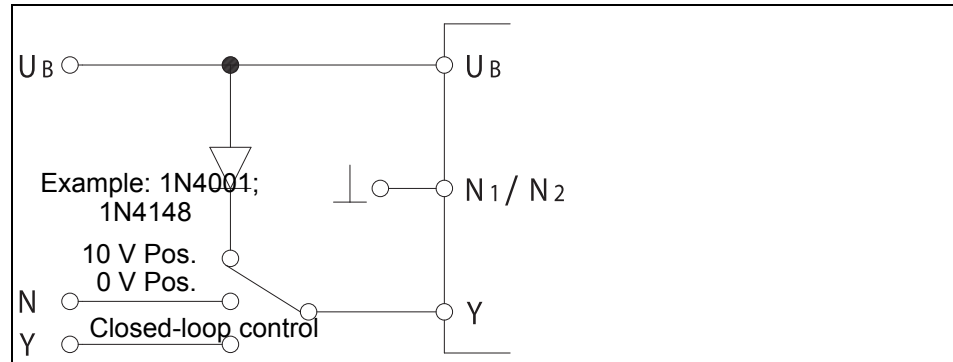

**diagram 7** Controller independent circuit

- 2 Using the toggle you can move the linear actuator to the following positions:

- Closed-loop control by input signal Y (normal operation)
- 10 V-position
- 0 V-Position, the linear actuator can be moved to the position on the plug-in jumper selected by jumper JP2 at 2 ... 10 V DC .

⇒ 5.1 *Operating parameters and jumper settings* on page 19

⇒ 5.5 *Setting the limit position for MC55Y and MC65Y* on page 21



### 4.5.2 Remove push-fit PCB and transformer MC55/230 and MC65/230

To change settings you have to remove the push-fit PCB (**107**) on the 230 V model.



#### Risk of injury from electric shock by live parts!

When the power supply is on there is a danger of electric shock due to live parts.

- Prior to commencing any work, ensure that the actuator is safely disconnected from the power supply system.
- Secure against unauthorised restarting.

- 1 Detach the two screws (**367**)
  - 2 Pull off the push-fit PCB (**107**) in a straight movement from the spacers (**27**) and hold the gear plate by pressing it against the motor.
  - 3 Access to plug-in jumpers (**113**) JP2 to JP5 is now established.
  - 4 After making changes to the setting carefully put the PCB back on.
- Hint:** When doing so, make sure that the socket strip fits correctly on the pin strip (**124**).
- 5 Tighten both screws (**367**).

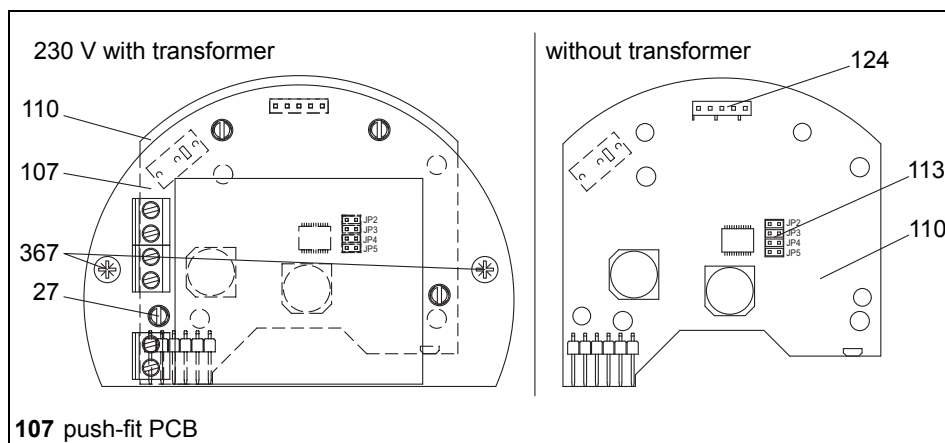

**diagram 8** Remove push-fit CB and transformer

## 5 Commissioning



### Risk of injury from electric shock by live parts!

When the power supply is on there is a danger of electric shock due to live parts.

- Prior to commencing any work, ensure that the actuator is safely disconnected from the power supply system.
- Secure against unauthorised restarting.

The jumpers on the plug-in jumper are used to set the operating parameters **(113)**. The plug-in jumper and the jumpers are underneath the push-fit PCB **(107)** in the actuator housing **(1)**.

⇒ 4.4 Assembling/disassembling the cover on page 13

⇒ 4.5.2 Remove push-fit PCB and transformer MC55/230 and MC65/230 on page 17

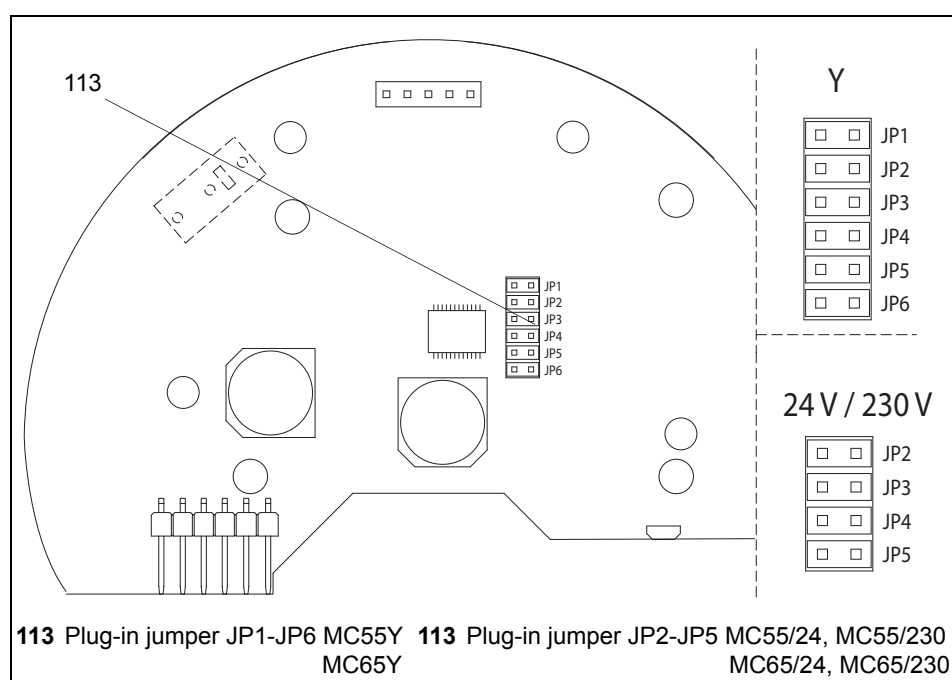

**diagram 9** Plug-in jumper position on the main PCB

## 5.1 Operating parameters and jumper settings

Before starting to operate the linear actuator you will have to set the operating parameters with the help of the jumpers.



### Malfunctions caused by incorrect jumper setting JP5

The jumper JP5 must be set to “on” at all times.

- Ensure that jumper JP5 is set to “on”.



Jumper	on 	off 
JP1	Input signal (Y) 0 ... 10 VDC or 0 ... 20 mA	Input signal (Y) 2 ... 10 VDC or 4 ... 20 mA
JP2	Limit position actuator spindle moved out	Limit position actuator spindle moved in
JP3	Actuating time 9 s/mm	Actuating time 5 s/mm
JP4	Y, X characteristic curve 	Y, X characteristic curve 
JP5	Ready for operation	-
JP6	Input signal (Y) in mA	Input signal (Y) in V

table 4 Jumper settings MC55Y and MC65Y



Jumper	on 	off 
JP2	No function	No function
JP3	Setting time 9 s/mm	Setting time 5 s/mm
JP4	X-characteristic curve 	X-characteristic curve 
JP5	Ready for operation	-

table 5 Jumper settings MC55/24, MC55/230 and MC65/24, MC65/230

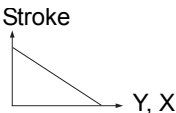
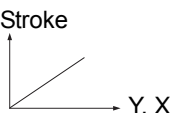
## 5.2 Setting the input signal for MC55Y and MC65Y

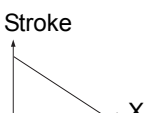
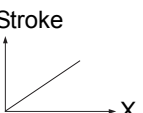
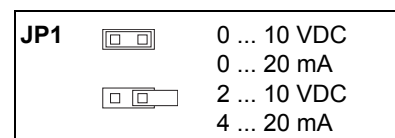
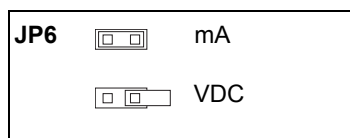

diagram 10 Setting the input signal

⇒ Additional information: *Input signal (Y)* on page 7

## 5.3 Setting the actuating time

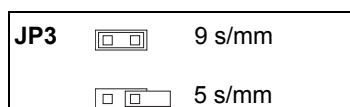

diagram 11 Set actuating time

⇒ 2.3.4 *Actuating time* on page 8

### 5.4 Setting the actuating direction

You can reverse the actuating direction for the linear actuators on the plug-in jumper (113) using jumper JP4 (reverse operation).











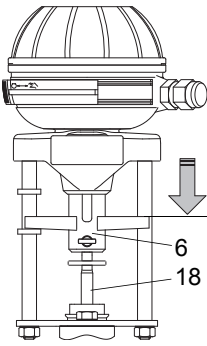









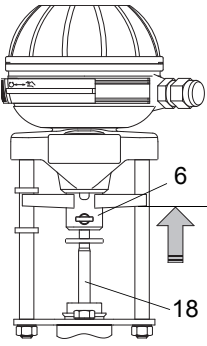

Actuator setting	Normal operation	Reverse operation
	<p>Y = 10 V DC Y = 20 mA X = 10 V DC</p> <p>JP6  JP6 </p>	<p>Y = 0 V DC Y = 2 V DC Y = 0 mA Y = 4 mA X = 0 V DC</p> <p>JP1  JP1  JP1  JP1 </p> <p>JP6  JP6  JP6  JP6 </p>
	<p>Y = 0 V DC Y = 2 V DC Y = 0 mA Y = 4 mA X = 0 V DC</p> <p>JP1  JP1  JP1  JP1 </p> <p>JP6  JP6  JP6  JP6 </p>	<p>Y = 10 V DC Y = 20 mA X = 10 V DC</p> <p>JP6  JP6 </p>
<b>JP4</b>		
<b>MC55Y MC65Y</b>	<p>Stroke</p> 	<p>Stroke</p> 
<b>MC55/24 MC55/230 MC65/24 MC65/230</b>	<p>Stroke</p> 	<p>Stroke</p> 

table 6 Setting the actuating direction

## 5.5 Setting the limit position for MC55Y and MC65Y

Use Jumper JP2 to select a limit position for the linear actuator.

- JP2 ON: Limit position with extended spindle nut
- JP2 OFF: Limit position with retracted spindle nut

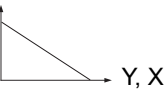
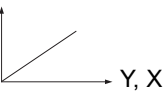
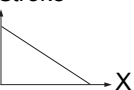
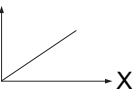
The limit position is approached in the following situations:

- Due to wire break detection by the Y signal (2 ... 10 V DC or 4 ... 20 mA only),
- Due to a binary signal (When electric circuit between terminal B1 and B2 is interrupted),

## 5.6 Commissioning

- 1 Check whether all fitting and assembly work has been competently finished.  
⇒ *4 Assembly* on page 11
- 2 Ensure that the electrical actuation of the linear actuator can take place safely without putting people or devices at risk.
- 3 Ensure that the linear actuator is attached correctly and that the cover of the linear actuator is closed.  
⇒ *4.4 Assembling/disassembling the cover* on page 13
- 4 Ensure that the linear actuator is set to automatic mode.  
⇒ *6.1 Changing between manual and automatic mode* on page 22
- 5 Ensure that the operating parameters are set correctly.  
⇒ *5.1 Operating parameters and jumper settings* on page 19
- 6 Apply supply voltage. The linear actuator will now move to the reference point.  
The linear actuator is ready for operation.

## 6 Operation

Prior to commissioning the linear actuator you will have to select the operating mode.

⇒ 5 Commissioning on page 18

### 6.1 Changing between manual and automatic mode

It is possible to run the linear actuator in automatic mode or manual mode (manual adjustment).

- In automatic mode the spindle nut moves to the position set by the controller.
- In manual mode it is possible to set the spindle manually, e. g. for control purposes. Output signal (X) is not available in manual mode.

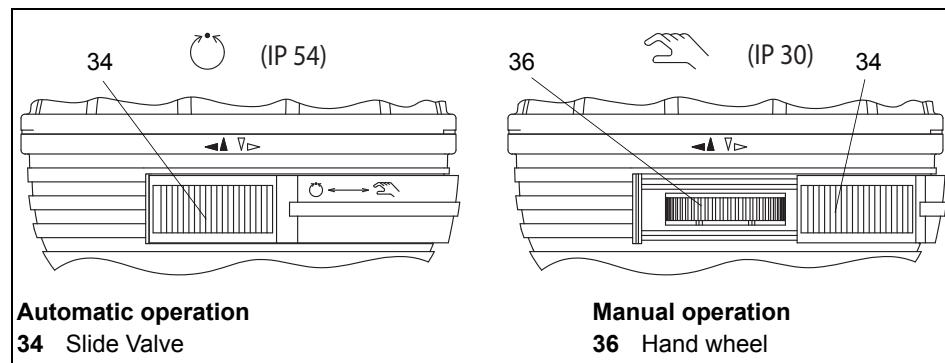

diagram 12 Selecting automatic mode

#### ■ How to change-over in manual mode

- 1 Push the slide bar (**34**) into manual position until you hear an audible locking sound.



ATTENTION

#### Risk of damage to valve and actuator during manual mode!

The valve may get damaged if it is pushed too hard into its receptacle during manual mode.

- Do not try and keep turning the hand wheel when you realise that the required effort increases noticeably!
- Never use force !

- 2 Use the hand wheel to turn the spindle nut to the desired position. Turn the hand wheel until the preset potentiometer increases. Do not use force!

#### ■ How to change-over in automatic mode

- 1 Push the slide bar to (**34**) position automatic mode.
- 2 The linear actuator first moves to both limit positions and afterwards to the position specified by the controller.

## 7 Maintenance, care and repairs

The linear actuator requires little maintenance. You do not have to carry out continuous or periodical maintenance.

## 8 Spare parts

When ordering accessories and spare parts please quote the specifications engraved on the type plate of your linear actuator. The specifications on the type plate are standard for the technical data of linear actuators as well as the requirements for the public power supply.



### Damage to device caused by faulty spare parts!

Spare parts must match the technical data specified by the manufacturer.

- Use genuine spare parts at all times.

⇒ 2.1 Component parts on page 6

## 9 Decommissioning and disposal

Dispose of the linear actuator according to national regulations and laws.

## 10 Removal of faults

### 10.1 How to remedy faults

If the linear actuator does not work properly follow the sequence of operations described below in order to remedy the fault:

- 1 Check whether the linear actuator was correctly assembled.
- 2 Check the settings for the linear actuator against the specifications on the type plate.
- 3 Remedy the fault by following the check list.  
⇒ 10.2 Check list for breakdown on page 24
- 4 If you are unable to remedy the fault contact the manufacturer.
- 5 For all queries at the manufacturer's and when sending back the device please quote the following :
  - SN (serial number = order number)
  - Type denomination
  - Supply voltage and frequency
  - Accessory equipment
  - Error report
- 6 If you are unable to remedy the fault despite inquiry you can send the device to the manufacturer.

## 10.2 Check list for breakdown

Fault	Cause/reason	Remedy
1. Linear actuator is not working.	Slide bar (34) in position manual mode	<input type="checkbox"/> Switch the slide bar to position automatic mode.
	Power cut	<input type="checkbox"/> Determine cause and remedy.
	Fuse defective (in control cabinet)	<input type="checkbox"/> Determine cause and remedy, replace fuse.
	Linear actuator incorrectly connected	<input type="checkbox"/> Set the connection correctly according to the wiring diagram (on the cover).
	Short circuit due to humidity	<input type="checkbox"/> Determine cause, dry the linear actuator; replace cover seal or screw joints and/or attach protective cover, as required.
	Short circuit due to incorrect connection	<input type="checkbox"/> Correct setting for connection
	Motor has winding damage (burnt-out) <ul style="list-style-type: none"> <li>• e.g. voltage too high</li> <li>• Electronic system defective</li> </ul>	<input type="checkbox"/> Determine cause, measure current data, Compare to type plate and table, Disassemble linear actuator and send it in for repairs.
2. Linear actuator running unsteadily, i. e. veering between clockwise and anti-clockwise rotation.	Drop of voltage due to excessively long connecting cables and / or insufficient diameter.	<input type="checkbox"/> Measure the current data; if required, recalculate and replace connecting cables!
	Public power supply fluctuations greater than admissible tolerance ⇒ 2.4 <i>Technical data</i> on page 9	<input type="checkbox"/> Improve public power supply conditions
3. Linear actuator pauses intermittently or initialises frequently	Slack contact in feeder line	<input type="checkbox"/> Check connections (terminal strips / connecting cables) and tighten, as required.
4. Linear actuator does not move to limit position. Valve does not open/close.	Valve is stuck	<input type="checkbox"/> Provide smooth-running valve
	Excessive system pressure	<input type="checkbox"/> Adjust system pressure
5. Linear actuator does not move at all or not correctly to the position preset by input signal Y	Input signal Y is faulty: <ul style="list-style-type: none"> <li>• Interfering signals</li> <li>• Signal variations</li> </ul>	<input type="checkbox"/> Check input signal Y on linear actuator, remove cause of fault
	Main PCB defective	<input type="checkbox"/> Disassemble the linear actuator and send it in for repair.

**table 7** Check list breakdown