

**FC-FCT SERIES
HYDRAULIC PERFORMANCE RANGE AT 50 Hz**

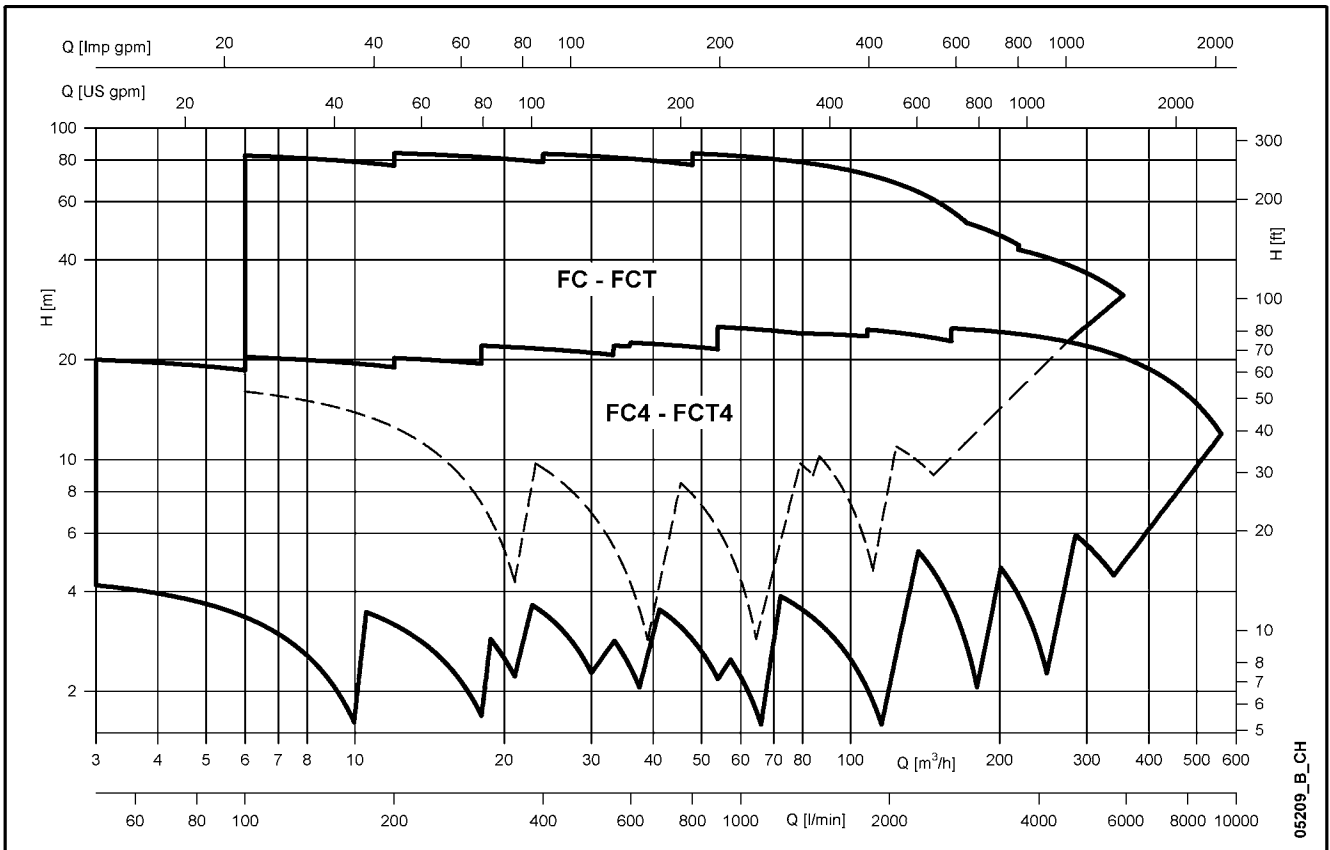

CONTENTS

FC Series Specifications	5
FC Series Construction Characteristics	6
FCT Series Specifications	7
FCT Series Construction Characteristics	8
List of Models and Table of Materials	10
Mechanical Seal	18
List of Models	19
Motors	20
Hydraulic Performance Range, FC Series 50 Hz, 2 Poles	30
Hydraulic Performance Range, FC Series 50 Hz, 4 Poles	32
Operating Characteristics, FC Series 50 Hz, 2 Poles	36
Operating Characteristics, FC Series 50 Hz, 4 Poles	46
Hydraulic Performance Range, FCT Series, Single Operation 50 Hz, 2 Poles	62
Hydraulic Performance Range, FCT Series, Parallel Operation 50 Hz, 2 Poles	64
Hydraulic Performance Range, FCT Series, Single Operation 50 Hz, 4 Poles	66
Hydraulic Performance Range, FCT Series, Parallel Operation 50 Hz, 4 Poles	68
Operating Characteristics, FCT Series, 50 Hz, 2 Poles	72
Operating Characteristics, FCT Series, 50 Hz, 4 Poles	82
FC Series Dimensions and Weights	97
FCT Series Dimensions and Weights	108
Accessories	118
Technical Appendix	123

In-Line Electric Pumps

FC Series



MARKET SECTORS

CIVIL, INDUSTRIAL.

APPLICATIONS

- Water circulation in heating and air conditioning systems.
- Handling of water and clean, chemically non-aggressive liquids.
- Water supply.
- Irrigation.

SPECIFICATIONS

PUMP

- **Delivery** up to 190 m³/h, 2-pole.
330 m³/h, 4-pole.
- **Head** up to 89 m, 2-pole.
35 m, 4-pole.
- **Temperature** of pumped liquid:
-10°C to +130°C for "E" version,
-20°C to +140°C for "S" version
(depending on working pressure).
- **Maximum working pressure:**
10 bar (PN 10) for the "E" version,
16 bar (PN 16) for the "S" version
up to 120°C, 13 bar from 120°C to
140°C.
- **Impeller** made of AISI 316L
stainless steel, **laser technology**
welded, up to size 80-160.
Cast iron impeller for bigger sizes.
Bronze impeller available on request
for FCT 80-200 and bigger, in both
the "E" and "S" versions.
- **Wear rings** made of AISI 316L
stainless steel, up to FC 100, on the
impeller's front and rear wear plates,
to ensure high performance and easy
replacement.
- **Mechanical seal** according to
EN12756 (ex DIN 24960), lubricated
by internal recirculation of pumped
liquid to seal housing (up to FC 100).
Mechanical seal locking pin slot on
models up to FC 100 (on request).
- Air valve on models up to FC 100.
- Counterflange kits available on
request.

MOTOR

- Three-phase asynchronous, squirrel cage rotor, enclosed construction, external ventilation.
- IP55 **protection**.
- Class 155 (F) **insulation**.
- Performances according to EN 60034-1.
- Maximum ambient temperature: +40°C.
- Continuous duty.
- Condensate drain plugs on all LOWARA motors.
- **Standard voltage:**
Single-phase version 220-240 V, 50 Hz, with built-in automatic reset overload protection up to 1,5 kW. For higher powers the protection is provided by the user.
Three-phase version:
220-240/380-415 V 50 Hz for powers up to 3 kW;
380-415/660-690 V, 50 Hz for powers above 3 kW.
Overload protection to be provided by the user.
- **Standard supplied IE2/IE3 motors are compliant with Regulation (EC) no. 640/2009 and IEC 60034-30.**

CONSTRUCTION FEATURES

Single-impeller centrifugal pump with in-line suction and delivery flanges.

Flanges in compliance with EN 1092-2 (ex UNI 2236) and DIN 2532.

“Back pull-out” design (impeller, adapter and motor can be extracted without disconnecting the pump body from the pipes).

FCE SERIES CHARACTERISTICS

Pump coupling: close-coupled by means of an adapter, with impeller keyed directly to the motor shaft extension.

Maximum operating pressure: 10 bar (PN 10).

Temperature of pumped liquid: -10°C to 130°C.

FCS SERIES CHARACTERISTICS

Pump coupling: by adapter, with bracket and rigid coupling keyed to the shaft extension of standard motors.

Maximum operating pressure: 16 bar (PN 16) up to 120°C, 13 bar from 120°C to 140°C.

Temperature of pumped liquid: -20°C to 140°C.

FC..H SERIES CHARACTERISTICS

Variable speed control, using the HIDROVAR® and HIDROVAR® Sensorless (on request), control system, is recommended for managing pump operation according to system conditions. This ensures energy savings, lower operating costs, greater comfort and environmental protection.

This option is available for both the FCE and FCS series, and includes the HIDROVAR® and HIDROVAR® Sensorless (on request) controller and sensors.

ACCESSORIES ON REQUEST

Threaded steel or galvanized iron counterflanges.

Blind flange.

Pump support.

OPTIONAL FEATURES

Different voltages and frequencies.

Different materials for the mechanical seal and pump body seal.

Support available for vertical mounting (where added).

INSTALLATION

Installed in horizontal or vertical piping, in any position except with motor or terminal box facing downward.

Motor powers 5,5 kW and higher, for installations with motor shaft in the vertical position, the electric pump should be mounted on a base, the pump should rest on its feet or on the support foot (optional accessory). For installations with motor shaft in the horizontal position, use a support foot for the motor.

FCE 40-100
FCE4 40-100

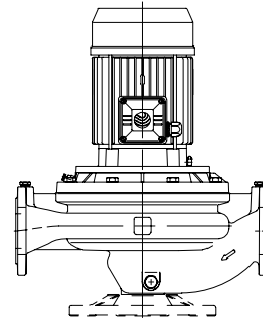

FCS 40-100
FCS4 40-100

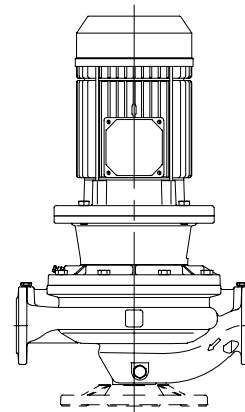

FCS4 125-150

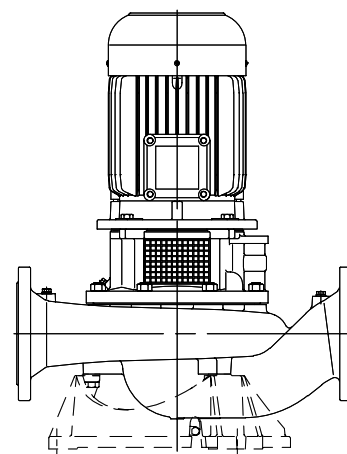

04807_C_SC

In-Line Twin Electric Pumps

FCT Series

MARKET SECTORS

CIVIL, INDUSTRIAL.

APPLICATIONS

- Water circulation in heating and air conditioning systems.
- Handling of water and clean, chemically non-aggressive liquids.
- Water supply.
- Irrigation.

SPECIFICATIONS

PUMP

- **Delivery** with one pump running: up to 190 m³/h with 2-pole motor, up to 330 m³/h with 4-pole motor; with two pumps running: up to 350 m³/h with 2-pole motor, up to 610 m³/h with 4-pole motor.
- **Head** up to 89 m with 2-pole motor, up to 35 m with 4-pole motor.
- **Temperature** of pumped liquid: -10 to 130°C for the "E" version, -20 to 140°C for the "S" version (depending on working pressure).

- **Maximum working pressure:** 10 bar (PN 10) for the "E" version, 16 bar (PN 16) for the "S" version up to 120°C, 13 bar from 120°C to 140°C.
- **Impeller** made of AISI 316L stainless steel, **laser technology** welded, up to size 80-160. Cast iron impeller for bigger sizes. Bronze impeller available on request for FCT 80-200 and bigger, in both the "E" and "S" versions.
- **Wear rings** made of AISI 316L stainless steel, up to FCT 100, on the impeller's front and rear wear plates, to ensure high performance and easy replacement.
- **Mechanical seal** according to EN12756 (ex DIN 24960), lubricated by internal recirculation of pumped liquid to seal housing (up to FCT 100). Mechanical seal locking pin slot on models up to FCT 100 (on request).

- Air valve on models up to FCT 100.
- Counterflange kits available on request.

MOTOR

- Three-phase asynchronous, squirrel cage rotor, enclosed construction, external ventilation.
- IP55 **protection**.
- Class 155 (F) **insulation**.
- Performances according to EN 60034-1.
- Maximum ambient temperature: +40°C.
- Continuous duty.
- Condensate drain plugs on all LOWARA motors.
- **Standard voltage:**
 - Single-phase** version 220-240 V, 50 Hz, with built-in automatic reset overload protection up to 1,5 kW. For higher powers the protection is provided by the user.
 - Three-phase** version: 220-240/380-415 V 50 Hz for powers up to 3 kW; 380-415/660-690 V, 50 Hz for powers above 3 kW. Overload protection to be provided by the user.
- **Standard supplied IE2/IE3 motors are compliant with Regulation (EC) no. 640/2009 and IEC 60034-30.**



CONSTRUCTION FEATURES

Two single-impeller centrifugal pumps featuring in-line suction and delivery flanges, with automatic changeover valve. The two pumps can operate separately or in parallel.

Flanges in compliance with EN 1092-2 (ex UNI 2236) and DIN 2532.

“Back pull-out” design (impeller, adapter and motor can be extracted without disconnecting the pump body from the pipes).

FCTE SERIES CHARACTERISTICS

Pump coupling: close-coupled by means of an adapter, with impeller keyed directly to the motor shaft extension.

Maximum operating pressure: 10 bar (PN 10).

Temperature of pumped liquid: -10°C to 130°C.

FCTS SERIES CHARACTERISTICS

Pump coupling: by adapter, with bracket and rigid coupling keyed to the shaft extension of standard motors.

Maximum operating pressure: 16 bar (PN 16) up to 120°C, 13 bar from 120°C to 140°C.

Temperature of pumped liquid: -20°C to 140°C.

FCT..H SERIES CHARACTERISTICS (ON REQUEST)

Variable speed control, using the HIDROVAR® and HIDROVAR® Sensorless (on request), control system, is recommended for managing pump operation according to system conditions. This ensures energy savings, lower operating costs, greater comfort and environmental protection.

This option is available for both the FCTE and FCTS series, and includes the HIDROVAR® and HIDROVAR® Sensorless controller and sensors.

ACCESSORIES ON REQUEST

Threaded steel or galvanized iron counterflanges.

Blind flange.

Pump support.

OPTIONAL FEATURES

Different voltages and frequencies.

Different materials for the mechanical seal and pump body seal.

Support available for vertical mounting.

Version with frequency converter (variable speed).

INSTALLATION

Can be installed on horizontal or vertical piping, in any position except with motor or terminal board facing downward.

With motor powers 5,5 kW and up, for installations with motor shaft in the vertical position, the electric pump should be mounted on a base, the pump should rest on its feet or on the support foot (optional accessory). For installations with motor shaft in the horizontal position, use a support for the motor.

FCTE 40-100
FCTE4 40-100

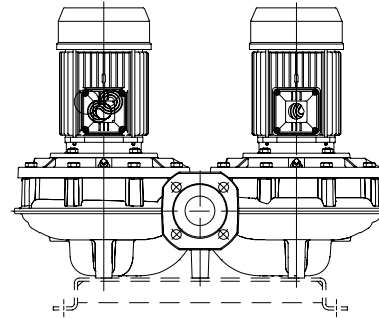

FCTS 40-100
FCTS4 40-100

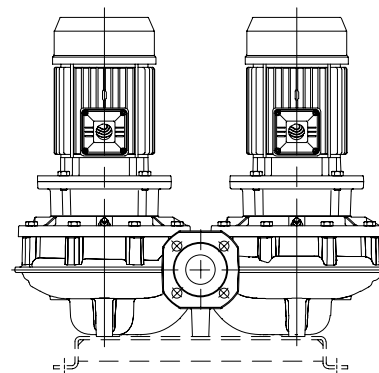

FCTS4 125-150

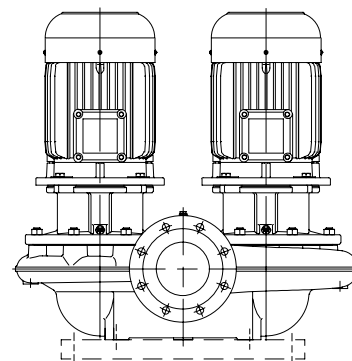

05207_B_SC

FC SERIES IDENTIFICATION CODE

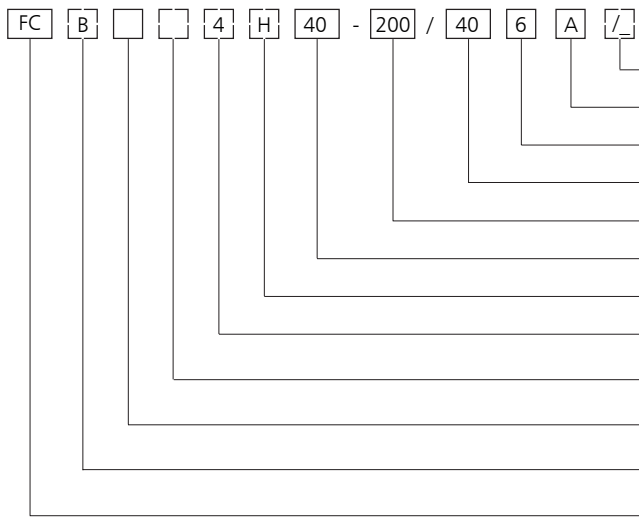

- Null or letter assigned by the manufacturer
- Reduced impeller
- Null = 50 Hz
6 = 60 Hz
- Rated motor power (kW x 10)
- Impeller nominal diameter (mm)
- Delivery port nominal diameter (mm)
- Version with Hydrovar
- Null = 2-pole motor
4 = 4-pole motor
- Null = Three-phase version
M = Single-phase version
- E = Close-coupled version
S = Version with rigid coupling, IEC standard motor
- Null = Version with steel or cast non impeller depending on size
B = Version with bronze impeller
- Series name

FCT SERIES IDENTIFICATION CODE

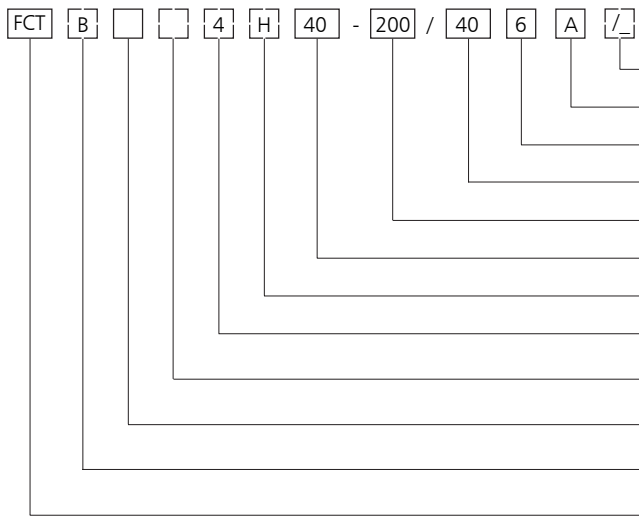

- Null or letter assigned by the manufacturer
- Reduced impeller
- Null = 50 Hz
6 = 60 Hz
- Rated motor power (kW x 10)
- Impeller nominal diameter (mm)
- Delivery port nominal diameter (mm)
- Version with Hydrovar
- Null = 2-pole motor
4 = 4-pole motor
- Null = Three-phase version
M = Single-phase version
- E = Close-coupled version
S = Version with rigid coupling, IEC standard motor
- Null = Version with steel or cast non impeller depending on size
B = Version with bronze impeller
- Series name

FC - FCT RATING PLATE

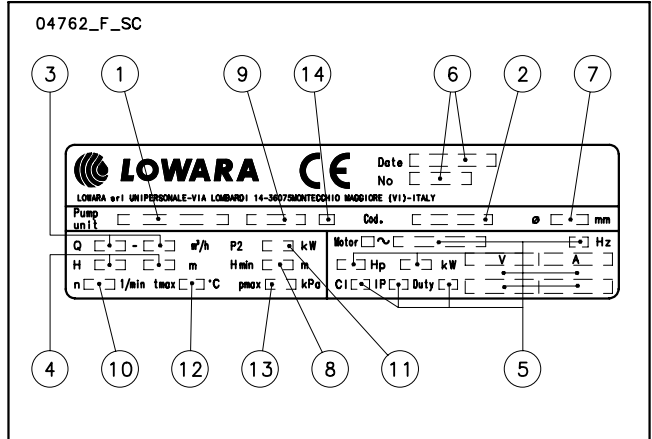

LEGEND

- 1 - Electric pump type
- 2 - Code
- 3 - Delivery range
- 4 - Head range
- 5 - Motor characteristics
- 6 - Date of manufacture and serial number
- 7 - Impeller diameter
- 8 - Minimum head
- 9 - Mechanical seal type
- 10 - Speed
- 11 - Rated output
- 12 - Maximum operating temperature
- 13 - Maximum operating pressure
- 14 - Type of gaskets

FCE-FCE4 SERIES LIST OF MODELS AND TABLE OF MATERIALS

04806_C_DS

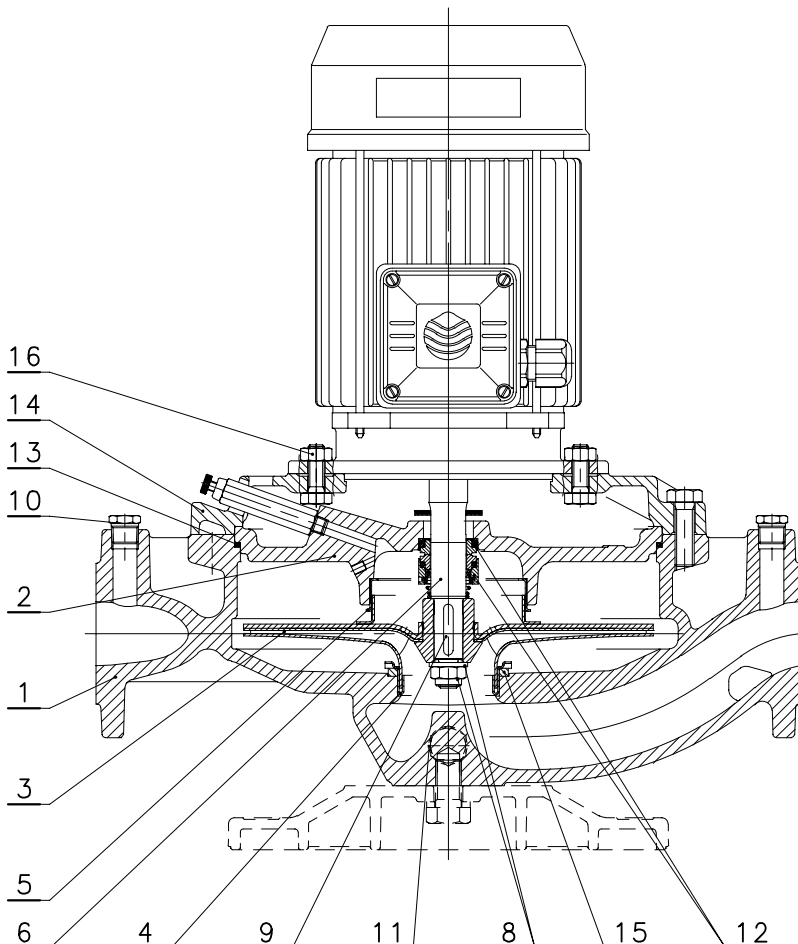

VERSIONS	
2 POLES	4 POLES
FCE 40-125/07	FCE4 40-200/05
FCE 40-125/11	FCE4 40-200/07
FCE 40-160/15	FCE4 40-250/11
FCE 40-160/22	FCE4 40-250/15
FCE 40-200/40A	FCE4 50-160/05
FCE 40-200/40	FCE4 50-200/07
FCE 40-200/55	FCE4 50-200/11
FCE 40-250/75	FCE4 50-250/15
FCE 40-250/110	FCE4 50-250/22
FCE 50-125/11	FCE4 65-125/05
FCE 50-125/15	FCE4 65-160/07
FCE 50-160/22	FCE4 65-160/11
FCE 50-160/30	FCE4 65-200/15
FCE 50-160/40	FCE4 65-250/22
FCE 50-200/55	FCE4 65-250/30
FCE 50-200/75	FCE4 80-125/07
FCE 50-250/92	FCE4 80-125/11
FCE 50-250/110	FCE4 80-200/15
FCE 50-250/150	FCE4 80-200/22
FCE 65-125/22	FCE4 80-200/30
FCE 65-125/30	FCE4 80-250/40
FCE 65-125/40	FCE4 80-250/55
FCE 65-160/55	FCE4 100-160/15
FCE 65-160/75	FCE4 100-200/22
FCE 65-200/92	FCE4 100-200/30
FCE 65-200/110	FCE4 100-250/40
FCE 65-250/150	FCE4 100-250/55
FCE 65-250/185	FCE4 100-250/75
FCE 65-250/220	
FCE 80-125/30	
FCE 80-125/40	
FCE 80-125/55	
FCE 80-160/75	
FCE 80-200/110	
FCE 80-200/150	
FCE 80-200/185	
FCE 80-200/220	
FCE 100-160/110	
FCE 100-200/185	
FCE 100-200/220	

fc-fce-fce4-en_a_mo

REF. N.	PART	MATERIAL	REFERENCE STANDARDS	
			EUROPE	USA
1	Pump body	Cast iron	EN 1561-GJL-200 (JL1030)	ASTM Class 25
2	Seal housing	Cast iron	EN 1561-GJL-200 (JL1030)	ASTM Class 25
3	Impeller	Stainless steel	EN 10088-1-X2CrNiMo17-12-2 (1.4404)	AISI 316L
	Impeller	Cast iron	EN 1561-GJL-200 (JL1030)	ASTM Class 25
	Impeller	Bronze	EN 1982-CuSn10-C (CC480K)	UNS C90700
4	Wear ring	Stainless steel	EN 10088-1-X2CrNiMo17-12-2 (1.4404)	AISI 316L
5	Counterwear ring	Stainless steel	EN 10088-1-X2CrNiMo17-12-2 (1.4404)	AISI 316L
6	Shaft extension	Stainless steel	EN 10088-1-X2CrNiMo17-12-2 (1.4404)	AISI 316L
8	Impeller lock nut and washer	Stainless steel	EN 10088-1-X5CrNiMo17-12-2 (1.4401)	AISI 316
9	Key	Stainless steel	EN 10088-1-X2CrNiMo17-12-2 (1.4404)	AISI 316L
10	Plugs and air valve	Nickel-plated brass	EN 12164-CuZn39Pb3 (CW614N)	-
11	Gaskets for fill/drain plugs	Aluminium	EN 573-AW-AI99,5 (AW1050A)	-
12	Mechanical seal	Carbon/Ceramic/EPDM (standard version)		
13	Elastomers	EPDM (standard version)		
14	Adapter *	Aluminium	EN 1706-AC-AISI11Cu2 (Fe) (AC46100)	-
	Adapter	Cast iron	EN 1561-GJL-200 (JL1030)	ASTM Class 25
15	Spacer ring	Painted steel		
16	Pump body fastening bolts and screws	Galvanized steel		

* For 40/50-125 2/4 pole, 40/50-160 2/4 pole versions

FCE4 SERIES LIST OF MODELS AND TABLE OF MATERIALS

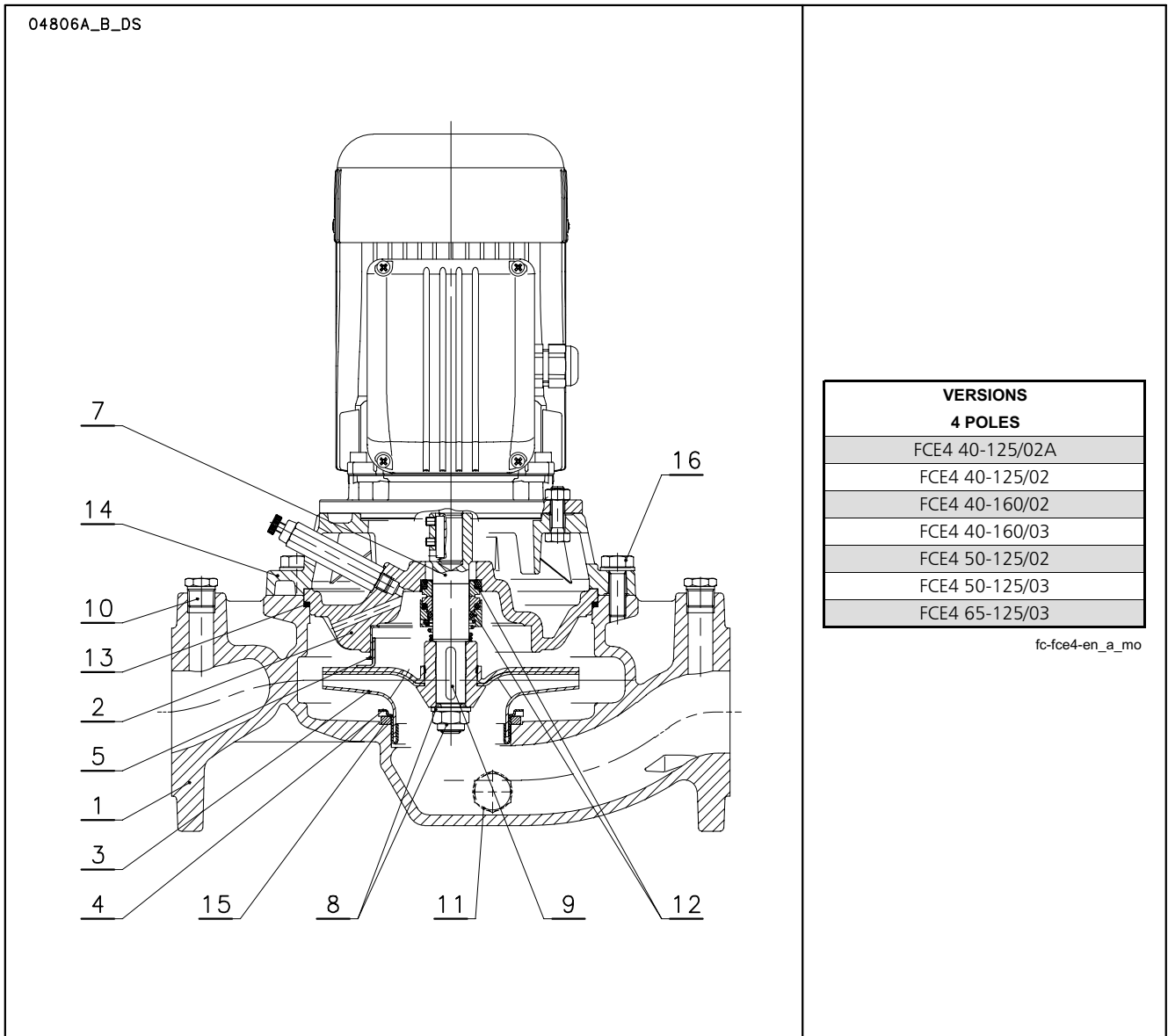

REF. N.	PART	MATERIAL	REFERENCE STANDARDS	
			EUROPE	USA
1	Pump body	Cast iron	EN 1561-GJL-200 (JL1030)	ASTM Class 25
2	Seal housing	Cast iron	EN 1561-GJL-200 (JL1030)	ASTM Class 25
3	Impeller	Stainless steel	EN 10088-1-X2CrNiMo17-12-2 (1.4404)	AISI 316L
4	Wear ring	Stainless steel	EN 10088-1-X2CrNiMo17-12-2 (1.4404)	AISI 316L
5	Counterwear ring	Stainless steel	EN 10088-1-X2CrNiMo17-12-2 (1.4404)	AISI 316L
7	Shaft rigid coupling	Stainless steel	EN 10088-1-X2CrNiMo17-12-2 (1.4404)	AISI 316L
8	Impeller lock nut and washer	Stainless steel	EN 10088-1-X5CrNiMo17-12-2 (1.4401)	AISI 316
9	Key	Stainless steel	EN 10088-1-X2CrNiMo17-12-2 (1.4404)	AISI 316L
10	Plugs and air valve	Nickel-plated brass	EN 12164-CuZn39Pb3 (CW614N)	-
11	Gaskets for fill/drain plugs	Aluminium	EN 573-AW-AI99,5 (AW1050A)	-
12	Mechanical seal	Carbon/Ceramic/EPDM (standard version)		
13	Elastomers	EPDM (standard version)		
14	Adapter *	Aluminium	EN 1706-AC-AISI11Cu2 (Fe) (AC46100)	-
	Adapter	Cast iron	EN 1561-GJL-200 (JL1030)	ASTM Class 25
15	Spacer ring	Painted steel		
16	Pump body fastening bolts and screws	Galvanizen steel		

* Per le versioni 40/50-125 2/4 poli, 40/50-160 2/4 poli

FCS-FCS4 SERIES LIST OF MODELS AND TABLE OF MATERIALS

04856_C_DS

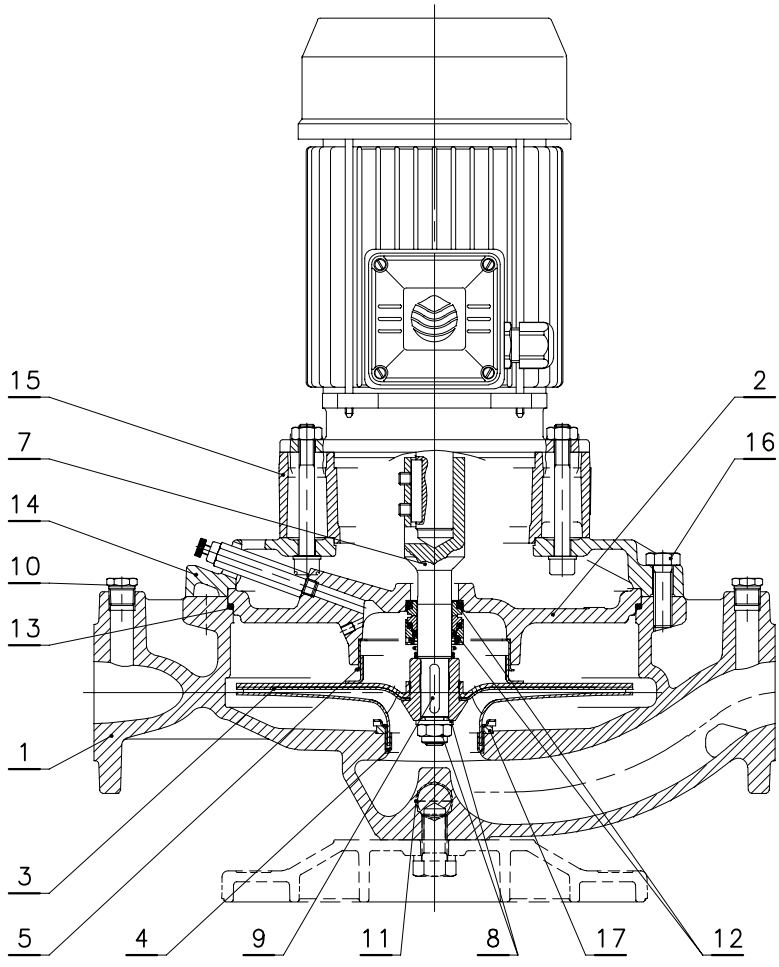

VERSIONS	
2 POLES	4 POLES
FCS 40-125/07	FCS4 40-200/05
FCS 40-125/11	FCS4 40-200/07
FCS 40-160/15	FCS4 40-250/11
FCS 40-160/22	FCS4 40-250/15
FCS 40-200/30	FCS4 50-200/07
FCS 40-200/40	FCS4 50-200/11
FCS 40-200/55	FCS4 50-250/15
FCS 40-250/75	FCS4 50-250/22
FCS 40-250/110	FCS4 65-160/07
FCS 50-125/11	FCS4 65-160/11
FCS 50-125/15	FCS4 65-200/15
FCS 50-160/22	FCS4 65-250/22
FCS 50-160/30	FCS4 65-250/30
FCS 50-160/40	FCS4 80-125/07
FCS 50-200/55	FCS4 80-125/11
FCS 50-200/75	FCS4 80-200/15
FCS 50-250/110A	FCS4 80-200/22
FCS 50-250/110	FCS4 80-200/30
FCS 50-250/150	FCS4 80-250/40
FCS 65-125/22	FCS4 80-250/55
FCS 65-125/30	FCS4 100-160/15
FCS 65-125/40	FCS4 100-200/22
FCS 65-160/55	FCS4 100-200/30
FCS 65-160/75	FCS4 100-250/40
FCS 65-200/110A	FCS4 100-250/55
FCS 65-200/110	FCS4 100-250/75
FCS 65-250/150	
FCS 65-250/185	
FCS 65-250/220	
FCS 80-125/30	
FCS 80-125/40	
FCS 80-125/55	
FCS 80-160/75	
FCS 80-200/110	
FCS 80-200/150	
FCS 80-200/185	
FCS 80-200/220	
FCS 100-160/110	
FCS 100-200/185	
FCS 100-200/220	

fc-fcs-fcs4-en_a_mo

REF. N.	PART	MATERIAL	REFERENCE STANDARDS	
			EUROPE	USA
1	Pump body	Cast iron	EN 1561-GJL-200 (JL1030)	ASTM Class 25
2	Seal housing	Cast iron	EN 1561-GJL-200 (JL1030)	ASTM Class 25
3	Impeller	Stainless steel	EN 10088-1-X2CrNiMo17-12-2 (1.4404)	AISI 316L
	Impeller	Cast iron	EN 1561-GJL-200 (JL1030)	ASTM Class 25
	Impeller	Bronze	EN 1982-CuSn10-C (CC480K)	UNS C90700
4	Wear ring	Stainless steel	EN 10088-1-X2CrNiMo17-12-2 (1.4404)	AISI 316L
5	Counterwear ring	Stainless steel	EN 10088-1-X2CrNiMo17-12-2 (1.4404)	AISI 316L
7	Shaft rigid coupling	Stainless steel	EN 10088-1-X2CrNiMo17-12-2 (1.4404)	AISI 316L
8	Impeller lock nut and washer	Stainless steel	EN 10088-1-X5CrNiMo17-12-2 (1.4401)	AISI 316
9	Key	Stainless steel	EN 10088-1-X2CrNiMo17-12-2 (1.4404)	AISI 316L
10	Plugs and air valve	Nickel-plated brass	EN 12164-CuZn39Pb3 (CW614N)	-
11	Gaskets for fill/drain plugs	Aluminium	EN 573-AW-AI99,5 (AW1050A)	-
12	Mechanical seal	Carbon/Silicon carbide/EPDM (standard version)		
13	Elastomers	EPDM (standard version)		
14	Adapter *	Aluminium	EN 1706-AC-AISI11Cu2 (Fe) (AC46100)	-
	Adapter *	Cast iron	EN 1561-GJL-200 (JL1030)	ASTM Class 25
15	Motor adapter coupling	Cast iron	EN 1561-GJL-200 (JL1030)	ASTM Class 25
16	Pump body fastening bolts and screws	Galvanized steel		
16	Spacer ring	Painted steel		

* For 40/50-125 2/4 pole, 40/50-160 2/4 pole versions

FCS4 SERIES
LIST OF MODELS AND TABLE OF MATERIALS

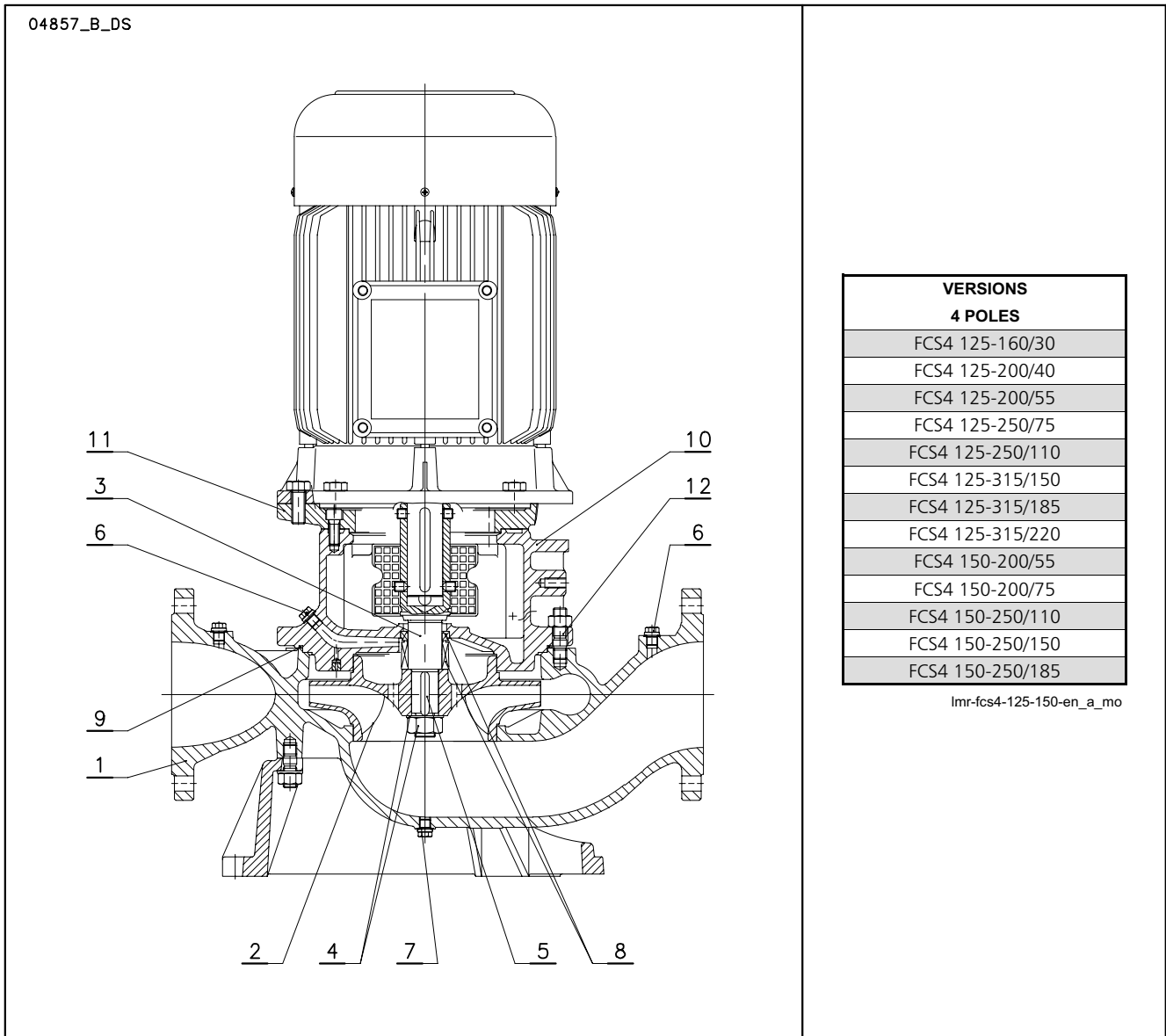

REF. N.	PART	MATERIAL	REFERENCE STANDARDS	
			EUROPE	USA
1	Pump body	Cast iron	EN 1561-GJL-250 (JL1040)	ASTM Class 35
2	Impeller	Cast iron	EN 1561-GJL-250 (JL1040)	ASTM Class 35
		Bronze	EN 1982-CuSn10-C (CC480K)	UNS C90700
3	Rigid coupling	Stainless steel	EN 10088-1-X20Cr13 (1.4021)	AISI 420
4	Impeller lock nut and washer	Steel		
5	Key	Steel	EN 10083-1-C45E (1.1191)	-
6	Plugs and air valve	Steel		
7	Gaskets for plugs	Asbestos-free synthetic fibre AFM34 ®		
8	Mechanical seal	Silicon carbide / Carbon / EPDM (standard version)		
9	Elastomers	EPDM (standard version)		
10	Adapter	Cast iron	EN 1561-GJL-250 (JL1040)	ASTM Class 35
11	Motor adapter coupling	Cast iron	EN 1561-GJL-250 (JL1040)	ASTM Class 35
12	Pump body fastening bolts and screws	Steel		

lmr_fcs4 125-150-en_a_tm

FCTE-FCTE4 SERIES LIST OF MODELS AND TABLE OF MATERIALS

05202_A_DS

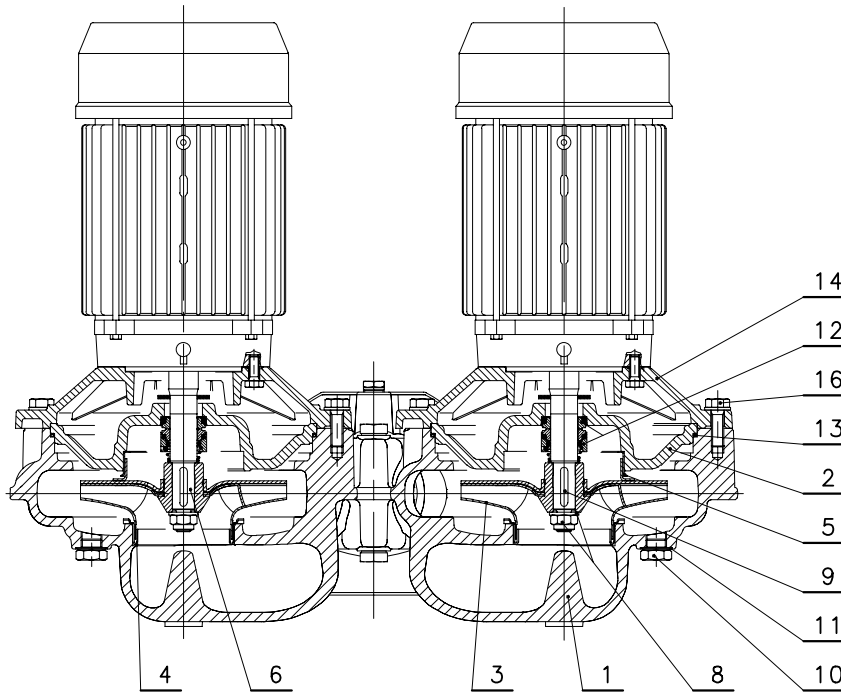

VERSIONS	
2 POLES	4 POLES
FCTE 40-125/07	FCTE4 40-200/05
FCTE 40-125/11	FCTE4 40-200/07
FCTE 40-160/15	FCTE4 40-250/11
FCTE 40-160/22	FCTE4 40-250/15
FCTE 40-200/40A	FCTE4 50-160/05
FCTE 40-200/40	FCTE4 50-200/07
FCTE 40-200/55	FCTE4 50-200/11
FCTE 40-250/75	FCTE4 50-250/15
FCTE 40-250/110	FCTE4 50-250/22
FCTE 50-125/11	FCTE4 65-125/05
FCTE 50-125/15	FCTE4 65-160/07
FCTE 50-160/22	FCTE4 65-160/11
FCTE 50-160/30	FCTE4 65-200/15
FCTE 50-160/40	FCTE4 65-250/22
FCTE 50-200/55	FCTE4 65-250/30
FCTE 50-200/75	FCTE4 80-125/07
FCTE 50-250/92	FCTE4 80-125/11
FCTE 50-250/110	FCTE4 80-200/15
FCTE 50-250/150	FCTE4 80-200/22
FCTE 65-125/22	FCTE4 80-200/30
FCTE 65-125/30	FCTE4 80-250/40
FCTE 65-125/40	FCTE4 80-250/55
FCTE 65-160/55	FCTE4 100-160/15
FCTE 65-160/75	FCTE4 100-200/22
FCTE 65-200/92	FCTE4 100-200/30
FCTE 65-200/110	FCTE4 100-250/40
FCTE 65-250/150	FCTE4 100-250/55
FCTE 65-250/185	FCTE4 100-250/75
FCTE 65-250/220	
FCTE 80-125/30	
FCTE 80-125/40	
FCTE 80-125/55	
FCTE 80-160/75	
FCTE 80-200/110	
FCTE 80-200/150	
FCTE 80-200/185	
FCTE 80-200/220	
FCTE 100-160/110	
FCTE 100-200/185	
FCTE 100-200/220	

fct-fcte-fcte4-en_a_mo

REF. N.	PART	MATERIAL	REFERENCE STANDARDS	
			EUROPE	USA
1	Pump body	Cast iron	EN 1561-GJL-250 (JL1040)	ASTM Class 35
2	Seal housing	Cast iron	EN 1561-GJL-200 (JL1030)	ASTM Class 25
3	Impeller	Stainless steel	EN 10088-1-X2CrNiMo17-12-2 (1.4404)	AISI 316L
	Impeller	Cast iron	EN 1561-GJL-200 (JL1030)	ASTM Class 25
	Impeller	Bronze	EN 1982-CuSn10-C (CC480K)	UNS C90700
4	Wear ring	Stainless steel	EN 10088-1-X2CrNiMo17-12-2 (1.4404)	AISI 316L
5	Counterwear ring	Stainless steel	EN 10088-1-X2CrNiMo17-12-2 (1.4404)	AISI 316L
6	Shaft extension	Stainless steel	EN 10088-1-X2CrNiMo17-12-2 (1.4404)	AISI 316L
8	Impeller lock nut and washer	Stainless steel	EN 10088-1-X5CrNiMo17-12-2 (1.4401)	AISI 316
9	Key	Stainless steel	EN 10088-1-X2CrNiMo17-12-2 (1.4404)	AISI 316L
10	Plugs and air valve	Ottone nichelato	EN 12164-CuZn39Pb3 (CW614N)	-
11	Gaskets for fill/drain plugs	Aluminium	EN 573-AW-AI99,5 (AW1050A)	-
12	Mechanical seal	Carbon/Ceramic/EPDM (standard version)		
13	Elastomers	EPDM (standard version)		
14	Adapter *	Aluminum	EN 1706-AC-AISI11Cu2 (Fe) (AC46100)	-
	Adapter *	Cast iron	EN 1561-GJL-200 (JL1030)	ASTM Class 25
16	Pump body fastening bolts and screws	Galvanized steel		
	Changeover valve	Stainless steel	EN 10088-1-X2CrNiMo17-12-2 (1.4404)	AISI 316L

* For 40/50-125 2/4 pole, 40/50-160 2/4 pole versions

FCTE4 SERIES LIST OF MODELS AND TABLE OF MATERIALS

05203_A_DS

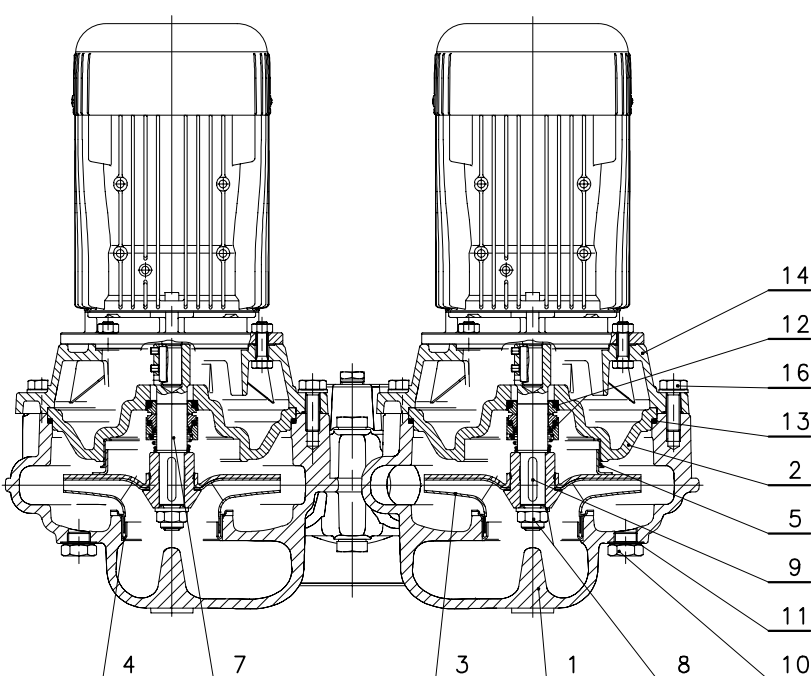

VERSIONS	
4 POLES	
FCTE4 40-125/02A	
FCTE4 40-125/02	
FCTE4 40-160/02	
FCTE4 40-160/03	
FCTE4 50-125/02	
FCTE4 50-125/03	
FCTE4 65-125/03	

fct-fcte4_a_mo

REF. N.	PART	MATERIAL	REFERENCE STANDARDS	
			EUROPE	USA
1	Pump body	Cast iron	EN 1561-GJL-250 (JL1040)	ASTM Class 35
2	Seal housing	Cast iron	EN 1561-GJL-200 (JL1030)	ASTM Class 25
3	Impeller	Stainless steel	EN 10088-1-X2CrNiMo17-12-2 (1.4404)	AISI 316L
4	Wear ring	Stainless steel	EN 10088-1-X2CrNiMo17-12-2 (1.4404)	AISI 316L
5	Counterwear ring	Stainless steel	EN 10088-1-X2CrNiMo17-12-2 (1.4404)	AISI 316L
7	Shaft rigid coupling	Stainless steel	EN 10088-1-X2CrNiMo17-12-2 (1.4404)	AISI 316L
8	Impeller lock nut and washer	Stainless steel	EN 10088-1-X5CrNiMo17-12-2 (1.4401)	AISI 316
9	Key	Stainless steel	EN 10088-1-X2CrNiMo17-12-2 (1.4404)	AISI 316L
10	Plugs and air valve	Nickel-plated brass	EN 12164-CuZn39Pb3 (CW614N)	-
11	Gaskets for fill/drain plugs	Aluminium	EN 573-AW-AI99,5 (AW1050A)	-
12	Mechanical seal	Carbon/Ceramic/EPDM (standard version)		
13	Elastomers	EPDM (standard version)		
14	Adapter *	Aluminium	EN 1706-AC-AISI11Cu2 (Fe) (AC46100)	-
	Adapter *	Cast iron	EN 1561-GJL-200 (JL1030)	ASTM Class 25
16	Pump body fastening bolts and screws	Galvanized steel		
	Changeover valve	Stainless steel	EN 10088-1-X2CrNiMo17-12-2 (1.4404)	AISI 316L

* For 40/50-125 2/4 pole, 40/50-160 2/4 pole versions

FCTS-FCTS4 SERIES LIST OF MODELS AND TABLE OF MATERIALS

05252_A_DS

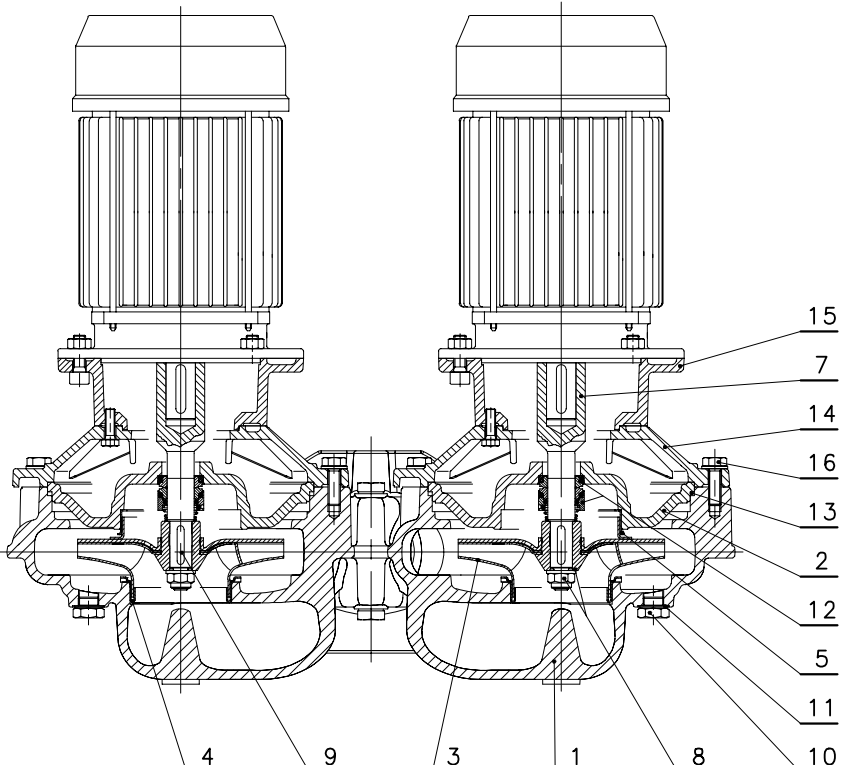

VERSIONS	
2 POLES	4 POLES
FCTS 40-125/07	FCTS4 40-200/05
FCTS 40-125/11	FCTS4 40-200/07
FCTS 40-160/15	FCTS4 40-250/11
FCTS 40-160/22	FCTS4 40-250/15
FCTS 40-200/30	FCTS4 50-200/07
FCTS 40-200/40	FCTS4 50-200/11
FCTS 40-200/55	FCTS4 50-250/15
FCTS 40-250/75	FCTS4 50-250/22
FCTS 40-250/110	FCTS4 65-160/07
FCTS 50-125/11	FCTS4 65-160/11
FCTS 50-125/15	FCTS4 65-200/15
FCTS 50-160/22	FCTS4 65-250/22
FCTS 50-160/30	FCTS4 65-250/30
FCTS 50-160/40	FCTS4 80-125/07
FCTS 50-200/55	FCTS4 80-125/11
FCTS 50-200/75	FCTS4 80-200/15
FCTS 50-250/110A	FCTS4 80-200/22
FCTS 50-250/110	FCTS4 80-200/30
FCTS 50-250/150	FCTS4 80-250/40
FCTS 65-125/22	FCTS4 80-250/55
FCTS 65-125/30	FCTS4 100-160/15
FCTS 65-125/40	FCTS4 100-200/22
FCTS 65-160/55	FCTS4 100-200/30
FCTS 65-160/75	FCTS4 100-250/40
FCTS 65-200/110A	FCTS4 100-250/55
FCTS 65-200/110	FCTS4 100-250/75
FCTS 65-250/150	
FCTS 65-250/185	
FCTS 65-250/220	
FCTS 80-125/30	
FCTS 80-125/40	
FCTS 80-125/55	
FCTS 80-160/75	
FCTS 80-200/110	
FCTS 80-200/150	
FCTS 80-200/185	
FCTS 80-200/220	
FCTS 100-160/110	
FCTS 100-200/185	
FCTS 100-200/220	

fct-fcts-fcts4-en_a_mo

REF. N.	PART	MATERIAL	REFERENCE STANDARDS	
			EUROPE	USA
1	Pump body	Cast iron	EN 1561-GJL-250 (JL1040)	ASTM Class 35
2	Seal housing	Cast iron	EN 1561-GJL-200 (JL1030)	ASTM Class 25
3	Impeller	Stainless steel	EN 10088-1-X2CrNiMo17-12-2 (1.4404)	AISI 316L
	Impeller	Cast iron	EN 1561-GJL-200 (JL1030)	ASTM Class 25
	Impeller	Bronze	EN 1982-CuSn10-C (CC480K)	UNS C90700
4	Wear ring	Stainless steel	EN 10088-1-X2CrNiMo17-12-2 (1.4404)	AISI 316L
5	Counterwear ring	Stainless steel	EN 10088-1-X2CrNiMo17-12-2 (1.4404)	AISI 316L
7	Shaft rigid coupling	Stainless steel	EN 10088-1-X2CrNiMo17-12-2 (1.4404)	AISI 316L
8	Impeller lock nut and washer	Stainless steel	EN 10088-1-X5CrNiMo17-12-2 (1.4401)	AISI 316
9	Key	Stainless steel	EN 10088-1-X2CrNiMo17-12-2 (1.4404)	AISI 316L
10	Plugs and air valve	Nickel-plated brass	EN 12164-CuZn39Pb3 (CW614N)	-
11	Gaskets for fill/drain plugs	Aluminium	EN 573-AW-AI99,5 (AW1050A)	-
12	Mechanical seal	Carbon/Silicon carbide/EPDM (standard version)		
13	Elastomers	EPDM (standard version)		
14	Adapter *	Aluminium	EN 1706-AC-AISI11Cu2 (Fe) (AC46100)	-
	Adapter	Cast iron	EN 1561-GJL-200 (JL1030)	ASTM Class 25
15	Motor adapter coupling	Cast iron	EN 1561-GJL-200 (JL1030)	ASTM Class 25
16	Pump body fastening bolts and screws	Galvanized steel		
	Changeover valve	Stainless steel	EN 10088-1-X2CrNiMo17-12-2 (1.4404)	AISI 316L

* For 40/50-125 2/4 pole, 40/50-160 2/4 pole versions

FCTS4 SERIES LIST OF MODELS AND TABLE OF MATERIALS

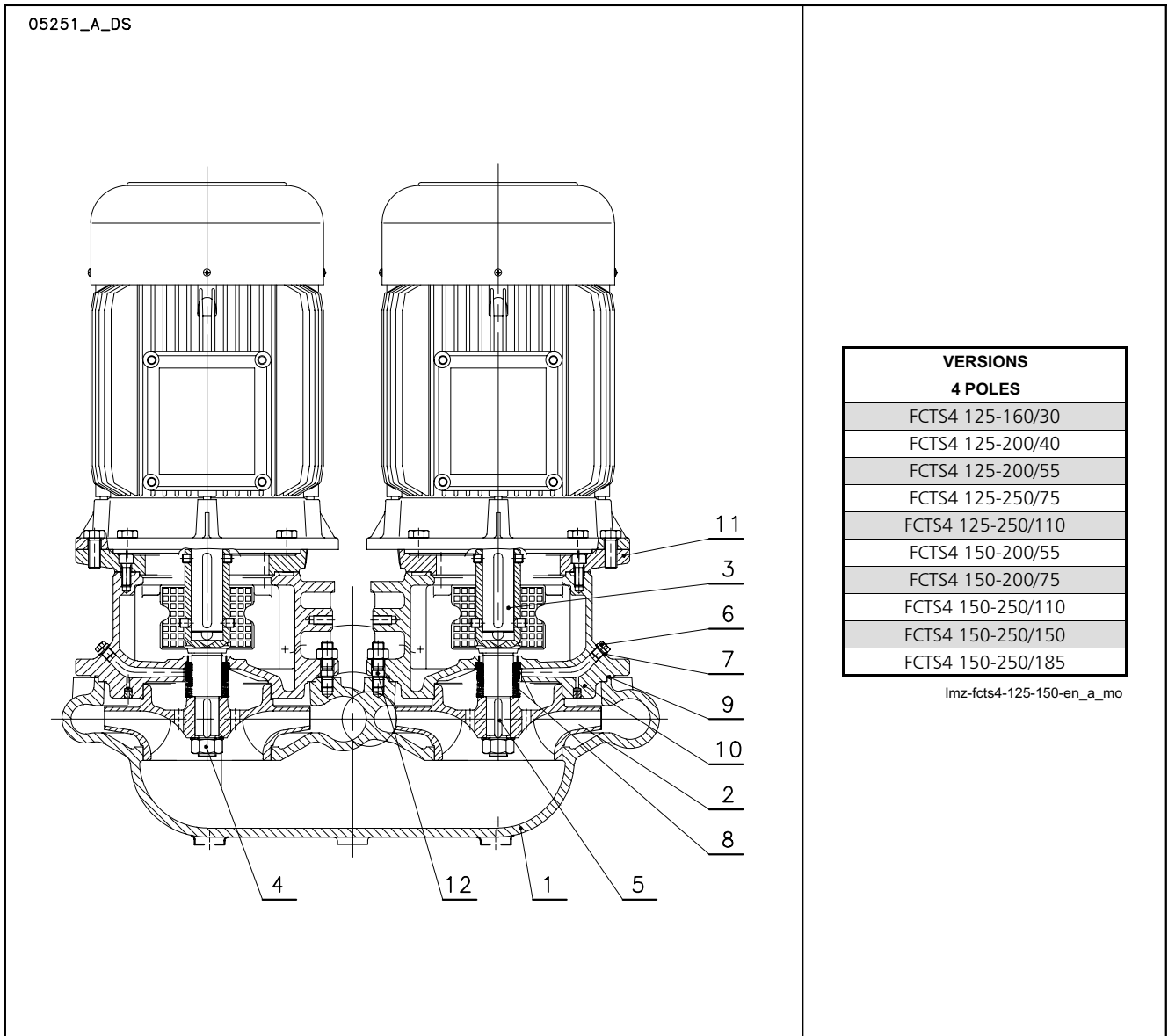

REF. N.	PART	MATERIAL	REFERENCE STANDARDS	
			EUROPE	USA
1	Pump body	Cast iron	EN 1561-GJL-250 (JL1040)	ASTM Class 35
2	Impeller	Cast iron	EN 1561-GJL-250 (JL1040)	ASTM Class 35
		Bronze	EN 1982-CuSn10-C (CC480K)	UNS C90700
3	Rigid coupling	Stainless steel	EN 10088-1-X20Cr13 (1.4021)	AISI 420
4	Impeller lock nut and washer	Steel		
5	Key	Steel	EN 10083-1-C45E (1.1191)	-
6	Plugs and air valve	Steel		
7	Gaskets for plugs	Asbestos-free synthetic fibre AFM34 ®		
8	Mechanical seal	Silicon carbide / Carbon / EPDM (standard version)		
9	Elastomers	EPDM (standard version)		
10	Adapter	Cast iron	EN 1561-GJL-250 (JL1040)	ASTM Class 35
11	Motor adapter coupling	Cast iron	EN 1561-GJL-250 (JL1040)	ASTM Class 35
12	Pump body fastening bolts and washer	Steel		
	Changeover valve	Steel		

FC-FCT MECHANICAL SEAL, ACCORDING TO EN 12756

Mechanical seal mounting dimensions according to EN12756 (ex DIN 24960) and ISO 3069.
(A version with anti-rotation lockpin is available on request.)

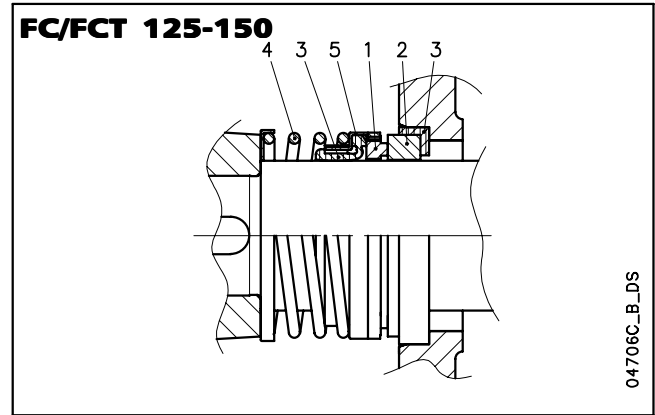
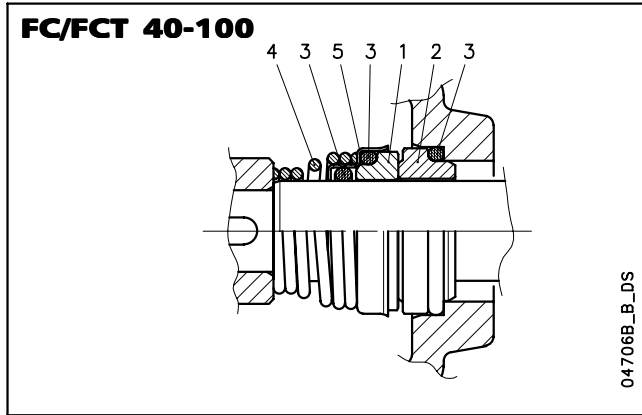

LIST OF MATERIALS

POSITION 1 - 2	POSITION 3	POSITION 4 - 5
Q ₁ : Silicon carbide	E : EPDM	G : AISI 316
B : Resin impregnated carbon	V : FPM	
V : Ceramic		

FCE - FCTE SEAL TYPE

fc-ct_ten-mec-en_a_tm

TYPE	POSITION					TEMPERATURE (°C)
	1 ROTATING ASSEMBLY	2 FIXED ASSEMBLY	3 ELASTOMERS	4 SPRINGS	5 OTHER COMPONENTS	
STANDARD MECHANICAL SEAL						
VBEGG	V	B	E	G	G	-10 +130
OTHER TYPES OF MECHANICAL SEAL						
Q ₁ BEGG	Q ₁	B	E	G	G	-10 +130
Q ₁ Q ₁ EGG	Q ₁	Q ₁	E	G	G	-10 +130
Q ₁ BVGG	Q ₁	B	V	G	G	-10 +120
Q ₁ Q ₁ VGG	Q ₁	Q ₁	V	G	G	-10 +120

FCS - FCTS SEAL TYPE

fcc-fcts_tipi-ten-mec-en_a_tc

TYPE	POSITION					TEMPERATURE (°C)
	1 ROTATING ASSEMBLY	2 FIXED ASSEMBLY	3 ELASTOMERS	4 SPRINGS	5 OTHER COMPONENTS	
STANDARD MECHANICAL SEAL						
Q ₁ BEGG	Q ₁	B	E	G	G	-20 +140
OTHER TYPES OF MECHANICAL SEAL						
Q ₁ Q ₁ EGG	Q ₁	Q ₁	E	G	G	-20 +140
Q ₁ BVGG	Q ₁	B	V	G	G	-10 +120
Q ₁ Q ₁ VGG	Q ₁	Q ₁	V	G	G	-10 +120

PRESSURE / TEMPERATURE APPLICATION LIMITS FOR COMPLETE PUMP (WITH ANY OF THE SEALS LISTED ABOVE)

fcc-fcts_tipi-ten-mec-en_a_tc

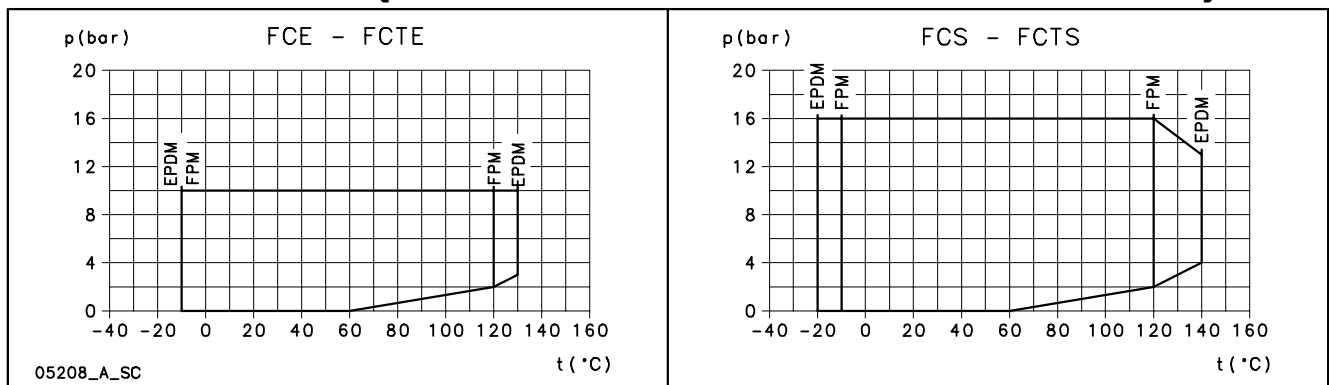

LIST OF FC SERIES MODELS 50 Hz
FC - FCT (2 POLES)

SIZE	kW	VERSION		
		FCEM FCTEM	FCE FCTE	FCS FCTS
40-125/07	0,75	•	•	•
40-125/11	1,1	•	•	•
40-160/15	1,5	•	•	•
40-160/22	2,2	•	•	•
40-200/30	3	-	-	•
40-200/40A	4	-	•	-
40-200/40	4	-	•	•
40-200/55	5,5	-	•	•
40-250/75	7,5	-	•	•
40-250/110	11	-	•	•
50-125/11	1,1	•	•	•
50-125/15	1,5	•	•	•
50-160/22	2,2	•	•	•
50-160/30	3	-	•	•
50-160/40	4	-	•	•
50-200/55	5,5	-	•	•
50-200/75	7,5	-	•	•
50-250/92	9,2	-	•	-
50-250/110A	11	-	-	•
50-250/110	11	-	•	•
50-250/150	15	-	•	•
65-125/22	2,2	•	•	•
65-125/30	3	-	•	•
65-125/40	4	-	•	•
65-160/55	5,5	-	•	•
65-160/75	7,5	-	•	•
65-200/92	9,2	-	•	-
65-200/110A	11	-	-	•
65-200/110	11	-	•	•
65-250/150	15	-	•	•
65-250/185	18,5	-	•	•
65-250/220	22	-	•	•
80-125/30	3	-	•	•
80-125/40	4	-	•	•
80-125/55	5,5	-	•	•
80-160/75	7,5	-	•	•
80-200/110	11	-	•	•
80-200/150	15	-	•	•
80-200/185	18,5	-	•	•
80-200/220	22	-	•	•
100-160/110	11	-	•	•
100-200/185	18,5	-	•	•
100-200/220	22	-	•	•

• = Available

fc_fce-fcs_2p50-en_b_tem

FC.4 - FCT.4 (4 POLES)

SIZE	kW	VERSION		
		FCE4 FCTE4	FCS4	FCTS4
40-125/02A	0,25	•	-	-
40-125/02	0,25	•	-	-
40-160/02	0,25	•	-	-
40-160/03	0,37	•	-	-
40-200/05	0,55	•	•	•
40-200/07	0,75	•	•	•
40-250/11	1,1	•	•	•
40-250/15	1,5	•	•	•
50-125/02	0,25	•	-	-
50-125/03	0,37	•	-	-
50-160/05	0,55	•	-	-
50-200/07	0,75	•	•	•
50-200/11	1,1	•	•	•
50-250/15	1,5	•	•	•
50-250/22	2,2	•	•	•
65-125/03	0,37	•	-	-
65-125/05	0,55	•	-	-
65-160/07	0,75	•	•	•
65-160/11	1,1	•	•	•
65-200/15	1,5	•	•	•
65-250/22	2,2	•	•	•
65-250/30	3	•	•	•
80-125/07	0,75	•	•	•
80-125/11	1,1	•	•	•
80-200/15	1,5	•	•	•
80-200/22	2,2	•	•	•
80-200/30	3	•	•	•
80-250/40	4	•	•	•
80-250/55	5,5	•	•	•
100-160/15	1,5	•	•	•
100-200/22	2,2	•	•	•
100-200/30	3	•	•	•
100-250/40	4	•	•	•
100-250/55	5,5	•	•	•
100-250/75	7,5	•	•	•
125-160/30	3	-	•	•
125-200/40	4	-	•	•
125-200/55	5,5	-	•	•
125-250/75	7,5	-	•	•
125-250/110	11	-	•	•
125-315/150	15	-	•	-
125-315/185	18,5	-	•	-
125-315/220	22	-	•	-
150-200/55	5,5	-	•	•
150-200/75	7,5	-	•	•
150-250/110	11	-	•	•
150-250/150	15	-	•	•
150-250/185	18,5	-	•	•

• = Available

fc_fce4-fcs4_4p50-en_b_tem

MOTORS FOR FC-FCT SERIES

Standard supplied IE2/IE3 three-phase surface motors $\geq 0,75$ kW are compliant with Regulation (EC) no. 640/2009 and IEC 60034-30.

Enclosed short circuit squirrel cage motor (TEFC), with external ventilation.

Electrical performances according to EN 60034-1.

Insulation class 155 (F).

IP55 protection.

Condensate drain plugs on standard version.

Cooling by fan according to EN 60034-6.

Cable gland metric size according to EN 50262.

Standard voltage:

- Single-phase version: 220-240 V 50 Hz, with incorporated automatic-reset overload protection up to 1,5 kW.
- Three-phase version: 220-240/380-415 V 50 Hz for powers up to 3 kW. 380-415/660-690 V 50 Hz for powers above 3 kW. Overload protection to be provided by the user.

SERIE FCE-FCTE MOTORI MONOFASE A 50 Hz, 2 POLI

P _N kW	MOTOR TYPE	IEC SIZE*	Construction Design	INPUT CURRENT I _n (A) 220-240 V	CAPACITOR		DATA FOR 230 V 50 Hz VOLTAGE						
					μF	V	min ⁻¹	I _s / I _n	η %	cosφ	T _n Nm	T _s /T _n	T _m /T _n
0,75	SM90RB14/107	90R	B14	4,83-5,23	30	450	2875	5,28	71,8	0,92	2,49	0,70	2,59
1,1	SM90RB14/111	90R	B14	6,88-6,65	30	450	2800	3,89	74,7	0,96	3,75	0,46	1,72
1,5	SM90RB14/115	90R	B14	9,21-8,58	40	450	2810	4,00	76,1	0,98	5,15	0,39	1,74
2,2	PLM90B14/122	90	B14	12,5-11,6	70	450	2825	4,47	82,4	0,97	7,43	0,53	1,87

* R = Reduced size of motor casing as compared to shaft extension and flange.

fhe-motm-2p50-en_d_te

FCE-FCTE SERIES THREE-PHASE MOTORS AT 50 Hz, 2 POLES

P _N kW	Efficiency η_N %																		IE	Year of manufacture																							
	Δ 220 V Y 380 V			Δ 230 V Y 400 V			Δ 240 V Y 415 V			Δ 380 V Y 660 V			Δ 400 V Y 690 V			Δ 415 V																											
	4/4	3/4	2/4	4/4	3/4	2/4	4/4	3/4	2/4	4/4	3/4	2/4	4/4	3/4	2/4	4/4	3/4	2/4																									
0,75	82,5	83,1	81,3	82,8	82,7	80,1	82,6	82,0	78,9	82,5	82,0	78,9	82,5	82,0	78,9	82,5	82,0	78,9	3	By June 2011																							
1,1	84,0	84,7	83,4	84,4	84,5	82,5	84,3	84,0	81,4	84,0	84,0	81,4	84,0	84,0	81,4	84,0	84,0	81,4			2																						
1,5	85,6	86,5	85,8	85,9	86,4	84,9	86,0	86,0	84,0	85,6	86,0	84,0	85,6	86,0	84,0	85,6	86,0	84,0																									
2,2	83,7	83,7	83,7	83,7	83,7	83,7	83,7	83,7	83,7	83,7	83,7	83,7	83,7	83,7	83,7	83,7	83,7	83,7																									
3	85,5	86,8	85,6	86,1	86,8	85,6	86,3	86,8	85,6	85,5	86,8	85,6	85,5	86,8	85,6	85,5	86,8	85,6																									
4	86,3	86,3	86,3	86,3	86,3	86,3	86,3	86,3	86,3	86,3	86,3	86,3	86,3	86,3	86,3	86,3	86,3	86,3																									
5,5	87,6	87,6	87,6	87,6	87,6	87,6	87,6	87,6	87,6	87,6	87,6	87,6	87,6	87,6	87,6	87,6	87,6	87,6																									
7,5	88,6	88,1	88,1	88,6	88,1	88,1	88,6	88,1	88,1	88,6	88,1	88,1	88,6	88,1	88,1	88,6	88,1	88,1																									
9,2	89,3	88,8	88,8	89,3	88,8	88,8	89,3	88,8	88,8	89,3	88,8	88,8	89,3	88,8	88,8	89,3	88,8	88,8																									
11	90,3	91,1	90,3	90,3	91,1	90,3	90,3	91,1	90,3	90,3	91,1	90,3	90,3	90,8	91,1	90,3	91,0	91,1																									
15	90,3	90,3	90,3	90,3	90,3	90,3	90,3	90,3	90,3	90,3	90,3	90,3	90,3	90,3	90,3	90,3	90,3	90,3																									
18,5	91,2	91,2	91,2	91,2	91,2	91,2	91,2	91,2	91,2	91,2	91,2	91,2	91,2	91,2	91,2	91,2	91,2	91,2																									
22	91,3	91,3	91,3	91,3	91,3	91,3	91,3	91,3	91,3	91,3	91,3	91,3	91,3	91,3	91,3	91,3	91,3	91,3																									

P _N kW	Manufacturer		IEC SIZE*	Construction Design	N. of Poles	f _N Hz	Data for 400 V / 50 Hz Voltage				
	Lowara srl Unipersonale Reg. No. 341820260 Montecchio Maggiore Vicenza - Italia						cos ϕ	I _s / I _N	T _N Nm	T _s /T _N	T _m /T _N
	Model										
0,75	SM90RB14/307PE		90R	SPECIAL	2	50	0,78	7,38	2,48	3,57	3,75
1,1	SM90RB14/311PE		90R				0,79	8,31	3,63	3,95	3,95
1,5	SM90RB14/315PE		90R				0,80	8,80	4,96	4,31	4,10
2,2	PLM90B14/322		90				0,80	8,63	7,25	3,74	3,71
3	PLM90B14/330		90				0,82	8,39	9,96	3,50	3,32
4	PLM112RB14/340		112R				0,85	9,52	13,1	3,04	4,40
5,5	PLM112B14/355		112				0,87	10,3	18,1	4,43	5,80
7,5	PLM132B14/375		132				0,87	9,21	24,5	3,26	4,55
9,2	PLM132B14/392		132				0,88	9,66	30,3	3,17	4,54
11	PLM132B14/3110		132				0,87	9,72	36,0	3,46	4,56
15	PLM160B14/3150		160				0,91	8,45	48,6	2,26	3,81
18,5	PLM160B14/3185		160				0,88	9,75	59,8	2,82	4,53
22	PLM160B14/3220		160				0,89	9,50	71,1	2,74	4,26

P _N kW	Voltage U _N V										n _N min ⁻¹	Observe the regulations and codes locally in force regarding sorted waste disposal.	Operating conditions **			
	Δ			Y			Δ			Y			Altitude Above Sea Level (m)	T. amb min/max °C	ATEX	
	220 V	230 V	240 V	380 V	400 V	415 V	380 V	400 V	415 V	660 V						690 V
0,75	2,96	2,94	2,96	1,71	1,70	1,71	1,70	1,69	1,70	0,98	0,98	2875 ÷ 2895	≤ 1000	-15 / 40	No	
1,1	4,19	4,14	4,16	2,42	2,39	2,40	2,41	2,38	2,38	1,39	1,37	2870 ÷ 2900				
1,5	5,56	5,49	5,51	3,21	3,17	3,18	3,21	3,18	3,19	1,85	1,84	2870 ÷ 2895				
2,2	8,05	8,04	8,09	4,65	4,64	4,67	4,62	4,61	4,63	2,67	2,66	2885 ÷ 2900				
3	10,8	10,6	10,6	6,23	6,14	6,12	6,18	6,10	6,06	3,57	3,52	2850 ÷ 2885				
4	13,6	13,5	13,5	7,88	7,77	7,79	7,80	7,63	7,65	4,51	4,41	2895 ÷ 2920				
5,5	18,3	18,0	17,9	10,6	10,4	10,3	10,6	10,4	10,5	6,14	6,02	2885 ÷ 2905				
7,5	25,4	24,8	24,4	14,7	14,3	14,1	14,5	14,0	13,9	8,35	8,11	2920 ÷ 2935				
9,2	29,7	28,9	28,3	17,2	16,7	16,4	17,3	16,8	16,6	10,0	9,70	2910 ÷ 2930				
11	36,0	35,1	34,7	20,8	20,3	20,0	20,8	20,3	20,1	12,0	11,7	2910 ÷ 2925				
15	47,2	45,3	44,0	27,2	26,2	25,4	27,2	26,0	25,3	15,7	15,0	2940 ÷ 2950				
18,5	58,3	56,9	55,9	33,7	32,9	32,3	34,1	33,2	32,8	19,7	19,1	2945 ÷ 2955				
22	68,3	66,2	64,3	39,4	38,2	37,1	40,0	38,6	37,8	23,1	22,3	2945 ÷ 2955				

* R = Reduced size of motor casing as compared to shaft extension and flange.

** Operating conditions to be referred to motor only. About electric pump, refer to limits in user's manual.

FCS-FCTS SERIES THREE-PHASE MOTORS AT 50 Hz, 2 POLES

P _N kW	Efficiency η_N %																		IE	Year of manufacture
	Δ 220 V Y 380 V			Δ 230 V Y 400 V			Δ 240 V Y 415 V			Δ 380 V Y 660 V			Δ 400 V Y 690 V			Δ 415 V				
	4/4	3/4	2/4	4/4	3/4	2/4	4/4	3/4	2/4	4/4	3/4	2/4	4/4	3/4	2/4	4/4	3/4	2/4		
0,75	82,5	83,1	81,3	82,8	82,7	80,1	82,6	82,0	78,9	82,5	82,0	78,9	82,5	82,0	78,9	82,5	82,0	78,9	3	By June 2011
1,1	84,0	84,7	83,4	84,4	84,5	82,5	84,3	84,0	81,4	84,0	84,0	81,4	84,0	84,0	81,4	84,0	84,0	81,4		
1,5	85,6	86,5	85,8	85,9	86,4	84,9	86,0	86,0	84,0	85,6	86,0	84,0	85,6	86,0	84,0	85,6	86,0	84,0		
2,2	83,7	83,7	83,7	83,7	83,7	83,7	83,7	83,7	83,7	83,7	83,7	83,7	83,7	83,7	83,7	83,7	83,7	83,7	2	
3	85,5	86,8	85,6	86,1	86,8	85,6	86,3	86,8	85,6	85,5	86,8	85,6	85,5	86,8	85,6	85,5	86,8	85,6		
4	86,3	86,3	86,3	86,3	86,3	86,3	86,3	86,3	86,3	86,3	86,3	86,3	86,3	86,3	86,3	86,3	86,3	86,3		
5,5	87,6	87,6	87,6	87,6	87,6	87,6	87,6	87,6	87,6	87,6	87,6	87,6	87,6	87,6	87,6	87,6	87,6	87,6		
7,5	88,6	88,1	88,1	88,6	88,1	88,1	88,6	88,1	88,1	88,6	88,1	88,1	88,6	88,1	88,1	88,6	88,1	88,1		
11	90,3	91,1	90,3	90,3	91,1	90,3	90,3	91,1	90,3	90,3	91,1	90,3	90,3	91,1	90,3	90,3	91,1	90,3		
15	90,3	90,3	90,3	90,3	90,3	90,3	90,3	90,3	90,3	90,3	90,3	90,3	90,3	90,3	90,3	90,3	90,3	90,3		
18,5	91,2	91,2	91,2	91,2	91,2	91,2	91,2	91,2	91,2	91,2	91,2	91,2	91,2	91,2	91,2	91,2	91,2	91,2		
22	91,3	91,3	91,3	91,3	91,3	91,3	91,3	91,3	91,3	91,3	91,3	91,3	91,3	91,3	91,3	91,3	91,3	91,3		

P _N kW	Manufacturer		IEC SIZE*	Construction Design	N. of Poles	f _N Hz	Data for 400 V / 50 Hz Voltage				
	Lowara srl Unipersonale Reg. No. 341820260 Montecchio Maggiore Vicenza - Italia						cos ϕ	I _s / I _N	T _N Nm	T _s /T _N	T _m /T _N
	Manufacturer										
0,75	SM80B5/307PE		80	B5	2	50	0,78	7,38	2,48	3,57	3,75
1,1	SM80B5/311PE		80				0,79	8,31	3,63	3,95	3,95
1,5	SM90RB5/315PE		90R				0,80	8,80	4,96	4,31	4,10
2,2	PLM90B5/322		90				0,80	8,63	7,25	3,74	3,71
3	PLM100RB5/330		100R				0,82	8,39	9,96	3,50	3,32
4	PLM112RB5/340		112R				0,85	9,52	13,1	3,04	4,40
5,5	PLM132RB5/355		132R				0,87	10,3	18,1	4,43	5,80
7,5	PLM132B5/375		132				0,87	9,21	24,5	3,26	4,55
11	PLM160RB5/3110		160R				0,87	9,72	36,0	3,46	4,56
15	PLM160B5/3150		160				0,91	8,45	48,6	2,26	3,81
18,5	PLM160B5/3185		160				0,88	9,75	59,8	2,82	4,53
22	PLM180RB5/3220		180R				0,89	9,50	71,1	2,74	4,26

P _N kW	Voltage U _N V										n _N min ⁻¹	Observe the regulations and codes locally in force regarding sorted waste disposal.	Operating conditions **			
	Δ			Y			Δ			Y			Altitude Above Sea Level (m)	T. amb min/max °C	ATEX	
	220 V	230 V	240 V	380 V	400 V	415 V	380 V	400 V	415 V	660 V						690 V
0,75	2,96	2,94	2,96	1,71	1,70	1,71	1,70	1,69	1,70	0,98	0,98	2875 ÷ 2895	≤ 1000	-15 / 40	No	
1,1	4,19	4,14	4,16	2,42	2,39	2,40	2,41	2,38	2,38	1,39	1,37	2870 ÷ 2900				
1,5	5,56	5,49	5,51	3,21	3,17	3,18	3,21	3,18	3,19	1,85	1,84	2870 ÷ 2895				
2,2	8,05	8,04	8,09	4,65	4,64	4,67	4,62	4,61	4,63	2,67	2,66	2885 ÷ 2900				
3	10,8	10,6	10,6	6,23	6,14	6,12	6,18	6,10	6,06	3,57	3,52	2850 ÷ 2885				
4	13,6	13,5	13,5	7,88	7,77	7,79	7,80	7,63	7,65	4,51	4,41	2895 ÷ 2920				
5,5	18,3	18,0	17,9	10,6	10,4	10,3	10,6	10,4	10,5	6,14	6,02	2885 ÷ 2905				
7,5	25,4	24,8	24,4	14,7	14,3	14,1	14,5	14,0	13,9	8,35	8,11	2920 ÷ 2935				
11	36,0	35,1	34,7	20,8	20,3	20,0	20,8	20,3	20,1	12,0	11,7	2910 ÷ 2925				
15	47,2	45,3	44,0	27,2	26,2	25,4	27,2	26,0	25,3	15,7	15,0	2940 ÷ 2950				
18,5	58,3	56,9	55,9	33,7	32,9	32,3	34,1	33,2	32,8	19,7	19,1	2945 ÷ 2955				
22	68,3	66,2	64,3	39,4	38,2	37,1	40,0	38,6	37,8	23,1	22,3	2945 ÷ 2955				

* R = Reduced size of motor casing as compared to shaft extension and flange.

fcs-fcts-ie2-mott-2p50-en_b_te

** Operating conditions to be referred to motor only. About electric pump, refer to limits in user's manual.

FCE4-FCTE4 SERIES THREE-PHASE MOTORS AT 50 Hz, 4 POLES

P _N kW	Efficiency η_N %																		Year of manufacture									
	Δ 220 V Y 380 V			Δ 230 V Y 400 V			Δ 240 V Y 415 V			Δ 380 V Y 660 V			Δ 400 V Y 690 V			Δ 415 V				IE								
	4/4	3/4	2/4	4/4	3/4	2/4	4/4	3/4	2/4	4/4	3/4	2/4	4/4	3/4	2/4	4/4	3/4	2/4										
0,25	-	-	-	-	-	-	-	-	-	-	-	-	-	-	-	-	-	-	-	-	-	-	By June 2011					
0,37	-	-	-	-	-	-	-	-	-	-	-	-	-	-	-	-	-	-	-	-	-	-						
0,55	-	-	-	-	-	-	-	-	-	-	-	-	-	-	-	-	-	-	-	-	-	-						
0,75	80,4	81,3	79,8	81,1	81,4	79,1	81,4	81,2	78,4	80,4	81,2	78,4	80,4	81,2	78,4	80,4	81,2	78,4	80,4	81,2	78,4	2						
1,1	81,4	81,4	81,1	81,4	81,4	81,1	81,4	81,4	81,1	81,4	81,4	81,1	81,4	81,4	81,1	81,4	81,4	81,1	81,4	81,4	81,1			By June 2011				
1,5	83,1	83,1	82,0	83,1	83,1	82,0	83,1	83,1	82,0	83,1	83,1	82,0	83,1	83,1	82,0	83,1	83,1	82,0	83,1	83,1	82,0				By June 2011			
2,2	84,7	84,7	84,7	84,7	84,7	84,7	84,7	84,7	84,7	84,7	84,7	84,7	84,7	84,7	84,7	84,7	84,7	84,7	84,7	84,7	84,7					By June 2011		
3	85,5	85,5	84,1	85,5	85,5	84,1	85,5	85,5	84,1	85,5	85,5	84,1	85,5	85,5	84,1	85,5	85,5	84,1	85,5	85,5	84,1						By June 2011	
4	86,6	86,6	86,6	86,6	86,6	86,6	86,6	86,6	86,6	86,6	86,6	86,6	86,6	86,6	86,6	86,6	86,6	86,6	86,6	86,6	86,6							By June 2011
5,5	88,0	88,0	88,0	88,0	88,0	88,0	88,0	88,0	88,0	88,0	88,0	88,0	88,0	88,0	88,0	88,0	88,0	88,0	88,0	88,0	88,0							
7,5	88,7	88,7	88,7	88,7	88,7	88,7	88,7	88,7	88,7	88,7	88,7	88,7	88,7	88,7	88,7	88,7	88,7	88,7	88,7	88,7	88,7	By June 2011						

P _N kW	Manufacturer		IEC SIZE*	Construction Design	N. of Poles	f _N Hz	Data for 400 V / 50 Hz Voltage				
	Lowara srl Unipersonale Reg. No. 341820260 Montecchio Maggiore Vicenza - Italia						cos ϕ	I _s / I _N	T _N Nm	T _s /T _N	T _m /T _N
	Model										
0,25	SM471B5S/302		71	SPECIAL	4	50	0,59	3,58	1,71	3,16	2,63
0,37	SM471B5S/304		71				0,60	3,39	2,57	3,40	2,47
0,55	SM490RB5(RB14)S/305		90R				0,67	3,95	3,77	2,45	2,38
0,75	LLM490RB5S/307		90R				0,75	5,78	5,03	2,77	3,31
1,1	PLM490B5S/311		90				0,72	6,34	7,27	2,80	3,43
1,5	PLM490B5S/315		90				0,67	6,79	9,88	3,33	3,67
2,2	PLM4100B5S/322		100				0,77	7,50	14,4	2,71	3,97
3	PLM4100B5S/330		100				0,73	7,84	19,6	2,96	4,09
4	PLM4112B5S/340		112				0,78	7,91	26,3	2,86	3,94
5,5	PLM4132B14S/355		132				0,78	7,89	35,9	2,79	3,47
7,5	PLM4132B14S/375		132	0,78	7,71	49,1	2,75	3,63			

P _N kW	Voltage U _N V											n _N min ⁻¹	Observe the regulations and codes locally in force regarding sorted waste disposal.	Operating conditions **		
	Δ			Y			Δ			Y				Altitude Above Sea Level (m)	T. amb min/max °C	ATEX
	220 V	230 V	240 V	380 V	400 V	415 V	380 V	400 V	415 V	660 V	690 V					
0,25	1,68	1,71	1,77	0,97	0,99	1,02	-	-	-	-	-	1375 ÷ 1400	≤ 1000	-15 / 40	No	
0,37	2,46	2,53	2,62	1,42	1,46	1,51	-	-	-	-	-	1355 ÷ 1380				
0,55	2,98	3,03	3,10	1,72	1,75	1,79	-	-	-	-	-	1380 ÷ 1400				
0,75	3,08	3,03	3,01	1,78	1,75	1,74	1,78	1,75	1,74	1,03	1,01	1410 ÷ 1430				
1,1	4,64	4,61	4,61	2,68	2,66	2,66	2,66	2,64	2,64	1,54	1,53	1435 ÷ 1445				
1,5	6,50	6,51	6,62	3,75	3,76	3,82	3,74	3,75	3,80	2,16	2,16	1440 ÷ 1450				
2,2	8,49	8,31	8,24	4,90	4,80	4,76	4,87	4,78	4,72	2,81	2,76	1445 ÷ 1455				
3	12,0	11,9	12,0	6,91	6,89	6,94	6,88	6,86	6,90	3,97	3,96	1455 ÷ 1465				
4	15,5	15,3	15,2	8,93	8,82	8,78	8,80	8,64	8,60	5,08	4,99	1445 ÷ 1455				
5,5	20,4	19,9	19,6	11,8	11,5	11,3	11,9	11,5	11,5	6,85	6,66	1455 ÷ 1465				
7,5	27,4	26,8	26,4	15,8	15,5	15,2	15,9	15,6	15,4	9,20	8,98	1450 ÷ 1460				

* R = Reduced size of motor casing as compared to shaft extension and flange.

fce4-fcte4-ie2-mott-4p50-en_a_tte

** Operating conditions to be referred to motor only. About electric pump, refer to limits in user's manual.

FCS4-FCTS4 SERIES THREE-PHASE MOTORS AT 50 Hz, 4 POLES (up to 15 kW)

P _N kW	Efficiency η_N																		IE	Year of manufacture	
	Δ 220 V			Δ 230 V			Δ 240 V			Δ 380 V			Δ 400 V			Δ 415 V					
	Y 380 V			Y 400 V			Y 415 V			Y 660 V			Y 690 V								
0,55	-	-	-	-	-	-	-	-	-	-	-	-	-	-	-	-	-	-	-	2	By June 2011
0,75	80,4	81,3	79,8	81,1	81,4	79,1	81,4	81,2	78,4	80,4	81,2	78,4	80,4	81,2	78,4	80,4	81,2	78,4			
1,1	81,4	81,4	81,1	81,4	81,4	81,1	81,4	81,4	81,1	81,4	81,4	81,1	81,4	81,4	81,1	81,4	81,4	81,1			
1,5	83,1	83,1	82,0	83,1	83,1	82,0	83,1	83,1	82,0	83,1	83,1	82,0	83,1	83,1	82,0	83,1	83,1	82,0			
2,2	84,7	84,7	84,7	84,7	84,7	84,7	84,7	84,7	84,7	84,7	84,7	84,7	84,7	84,7	84,7	84,7	84,7	84,7			
3	85,5	85,5	84,1	85,5	85,5	84,1	85,5	85,5	84,1	85,5	85,5	84,1	85,5	85,5	84,1	85,5	85,5	84,1			
4	86,6	86,6	86,6	86,6	86,6	86,6	86,6	86,6	86,6	86,6	86,6	86,6	86,6	86,6	86,6	86,6	86,6	86,6			
5,5	88,0	88,0	88,0	88,0	88,0	88,0	88,0	88,0	88,0	88,0	88,0	88,0	88,0	88,0	88,0	88,0	88,0	88,0			
7,5	88,7	88,7	88,7	88,7	88,7	88,7	88,7	88,7	88,7	88,7	88,7	88,7	88,7	88,7	88,7	88,7	88,7	88,7			
11	89,8	89,8	89,8	89,8	89,8	89,8	89,8	89,8	89,8	89,8	89,8	89,8	89,8	89,8	89,8	89,8	89,8	89,8			
15	90,6	90,6	89,9	90,6	90,6	89,9	90,6	90,6	89,9	90,6	90,6	89,9	90,6	90,6	89,9	90,6	90,6	89,9			

P _N kW	Manufacturer		IEC SIZE	Construction Design	N. of Poles	f _N Hz	Data for 400 V / 50 Hz Voltage				
	Lowara srl Unipersonale Reg. No. 341820260 Montecchio Maggiore Vicenza - Italia						cos ϕ	I _s / I _N	T _N Nm	T _s /T _N	T _m /T _N
	Model										
0,55	SM480B5/305		80	B5	4	50	0,67	3,95	3,77	2,45	2,38
0,75	LLM480B5/307		80				0,75	5,78	5,03	2,77	3,31
1,1	PLM490B5/311		90				0,72	6,34	7,27	2,80	3,43
1,5	PLM490B5/315		90				0,67	6,79	9,88	3,33	3,67
2,2	PLM4100B5/322		100				0,77	7,50	14,4	2,71	3,97
3	PLM4100B5/330		100				0,73	7,84	19,6	2,96	4,09
4	PLM4112B5/340		112				0,78	7,91	26,3	2,86	3,94
5,5	PLM4132B5/355		132				0,78	7,89	35,9	2,79	3,47
7,5	PLM4132B5/375		132				0,78	7,71	49,1	2,75	3,63
11	PLM4160B5/3110		160				0,83	6,94	71,6	2,34	3,02
15	PLM4160B5/3150		160				0,78	7,63	97,2	2,61	3,63

P _N kW	Voltage U _N V											n _N min ⁻¹	Observe the regulations and codes locally in force regarding sorted waste disposal.	Operating conditions **		
	Δ			Y			Δ			Y				Altitude Above Sea Level (m)	T. amb min/max °C	ATEX
	220 V	230 V	240 V	380 V	400 V	415 V	380 V	400 V	415 V	660 V	690 V					
	I _N (A)															
0,55	2,98	3,03	3,1	1,72	1,75	1,79	-	-	-	-	-	1380 ÷ 1400	≤ 1000	-15 / 40	No	
0,75	3,08	3,03	3,01	1,78	1,75	1,74	1,78	1,75	1,74	1,03	1,01	1410 ÷ 1430				
1,1	4,64	4,61	4,61	2,68	2,66	2,66	2,66	2,64	2,64	1,54	1,53	1435 ÷ 1445				
1,5	6,50	6,51	6,62	3,75	3,76	3,82	3,74	3,75	3,80	2,16	2,16	1440 ÷ 1450				
2,2	8,49	8,31	8,24	4,90	4,80	4,76	4,87	4,78	4,72	2,81	2,76	1445 ÷ 1455				
3	12,0	11,9	12,0	6,91	6,89	6,94	6,88	6,86	6,90	3,97	3,96	1455 ÷ 1465				
4	15,5	15,3	15,2	8,93	8,82	8,78	8,80	8,64	8,60	5,08	4,99	1445 ÷ 1455				
5,5	20,4	19,9	19,6	11,8	11,5	11,3	11,9	11,5	11,5	6,85	6,66	1455 ÷ 1465				
7,5	27,4	26,8	26,4	15,8	15,5	15,2	15,9	15,6	15,4	9,20	8,98	1450 ÷ 1460				
11	38,3	37,9	37,9	22,1	21,9	21,9	21,8	21,2	21,1	12,6	12,3	1465 ÷ 1470				
15	52,2	52,1	52,8	30,1	30,1	30,5	30,4	30,4	31,0	17,6	17,6	1470 ÷ 1475				

** Operating conditions to be referred to motor only. About electric pump, refer to limits in user's manual.

fcs4-fcts4-ie2-mott15-4p50-en_a_tu

SERIE FCS4-FCTS4 MOTORI TRIFASE A 50 Hz, 4 POLI (da 18,5 a 22 kW)

P _N kW	Efficiency η_N %									IE	Year of manufacture
	Δ 380 V Y 660 V			Δ 400 V Y 690 V			Δ 415 V				
	4/4	3/4	2/4	4/4	3/4	2/4	4/4	3/4	2/4		
18,5	91,2	91,7	91,8	91,5	91,8	91,6	91,7	91,7	91,1	2	By June 2011
22	91,9	92,4	92,5	92,2	92,5	92,3	92,4	92,4	91,8		

P _N kW	Manufacturer		IEC SIZE	Construction Design	N. of Poles	f _N Hz	Data for 400 V / 50 Hz Voltage				
	WEG Equipamentos Elétricos S.A. Reg. No. 07.175.725/0010-50 Jaragua do Sul - SC (Brazil)						cos ϕ	I _s / I _N	T _N Nm	T _s /T _N	T _m /T _n
	Model										
18,5	W22 180M4-B5 18.5kW		180	B5	4	50	0,83	6,60	121,0	2,40	2,80
22	W22 180L4-B5 22kW		180				0,85	6,80	143,0	2,60	2,90

P _N kW	Voltage U _N V					n _N min ⁻¹	See note.	Operating conditions **		
	Δ			Y				Altitude Above Sea Level (m)	T. amb min/max °C	ATEX
	380 V	400 V	415 V	660 V	690 V					
	I _N (A)									
18,5	36,30	35,10	34,70	20,90	20,35	1460 ÷ 1470	≤ 1000	-15 / 40	No	
22	41,80	40,50	39,90	24,70	23,48	1460 ÷ 1465				

** Operating conditions to be referred to motor only. About electric pump, refer to limits in user's manual.

fcs4-fcts4-ie2-mott22-4p50-en_a_te

Note: Observe the regulations and codes locally in force regarding sorted waste disposal.

MOTOR NOISE

The tables below show the mean sound pressure levels (Lp) measured at 1 meter's distance in a free field according to the A curve (ISO 1680 standard).

The noise values are measured with idling 50 Hz motor with a tolerance of 3 dB (A).

FCE-FCS-FCTE-FCTS MOTORS 50 Hz 2-POLE

POWER	MOTOR TYPE	NOISE
kW	IEC SIZE *	LpA dB
0,75	80 - 90R	<70
1,1	80 - 90R	<70
1,5	90 - 90R	<70
2,2	90	<70
3	90 - 100R	<70
4	112R	<70
5,5	112 - 132R	<70
7,5	132	71
9,2	132	73
11	132 - 160R	73
15	160	71
18,5	160	73
22	160	70

*R=Reduced size of motor casing as compared to shaft extension and flange.

FCE4-FCS4-FCTE4-FCTS4 MOTORS 50 Hz 4-POLE

POWER	MOTOR TYPE	NOISE
kW	IEC SIZE *	LpA dB
0,25	71	<70
0,37	71	<70
0,55	80 - 90R	<70
0,75	80 - 90R	<70
1,1	90	<70
1,5	90	<70
2,2	100	<70
3	100	<70
4	112	<70
5,5	132	<70
7,5	132	<70
11	160	<70
15	160	<70
18,5	180	<70
22	180	<70

fce-fcs-fcte-fcts_mott-en_b_tr

FCH-FCTH SERIES ELECTRIC PUMPS WITH HYDROVAR® AND HYDROVAR® SENSORLESS CONTROL SYSTEM

We recommend the use of the FC-FCT series electric pumps combined with the HYDROVAR® and HYDROVAR® Sensorless devices.

HYDROVAR® and HYDROVAR® Sensorless are micro-processor controlled devices for pumping systems, designed to control pump operation according to system conditions and requirements.

This way the simple electric pump is transformed into a complete pumping system principally designed for air-conditioning and heating applications, adapting the differential pressure of the closed circuit to the requested load.

- **No special pumps or motors:**

HYDROVAR® is mounted directly onto a standard three-phase TEFC motor with class F insulation up to 22 kW power. (HYDROVAR® Sensorless up to 4 kW).

- HYDROVAR® Sensorless enables the control of an electric circulator pump by monitoring the power control, without requiring a differential pressure transmitter.

- **No separate control panels or converters:** HYDROVAR® and HYDROVAR® Sensorless, perform all the functions of a pump control panel, incorporating protections against overload, short circuit, high temperature, etc. The only external device required is a fuse on the power supply line. Will depend upon any local electrical installation regulations.

- **No by-pass lines or safety systems:** With HYDROVAR® the pump switches off immediately when demand is zero or exceeds the maximum capacity of the pump. This way there is no need to install additional safety devices.

- **The pump's operation at the correct speed based on system requirements enables energy consumption to be substantially reduced.**



GENERAL OPERATING PRINCIPLES OF THE HYDROVAR® SYSTEM

The basic function of the HYDROVAR® device is to control the pump to meet the system demands.

For the FC and FCT series electric pumps, typical operation consists in system regulation based on the characteristic curve (B).

HYDROVAR® performs these functions by:

- 1) Measuring the system pressure or flow via a transmitter mounted on the pump's delivery side.
- 2) Calculating the motor speed to maintain the correct flow or pressure.
- 3) Sending out a signal to the pump to start the motor, increase speed, decrease speed or stop.
- 4) In the case of multiple pump installations, HYDROVAR® will automatically provide for the cyclic changeover of the pumps' starting sequence

In addition to these basic functions, HYDROVAR® can do things only by the most advanced computerised control systems, such as:

- Stop the pump(s) at zero demand.
- Stop the pump(s) in case of water failure on the suction side (protection against dry running).
- Stop the pump if the required delivery exceeds the pump's capacity (protection against cavitation caused by excessive demand), or automatically switch on the next pump in a multiple series.
- Protect the pump and motor from overvoltage, undervoltage, overload and earth fault.
- Vary the pump speed acceleration and deceleration time.
- Compensate for increased flow resistance at high flow rates.
- Conduct automatic test starts at set intervals.
- Monitor the converter and motor operating hours.
- Display all functions on an LCD in different languages (Italian, English, French, German, Spanish, Portuguese, Dutch).
- Send a signal to a remote control system which is proportional to the pressure and frequency.
- Communicate with another HYDROVAR or control system via an RS 485 interface.

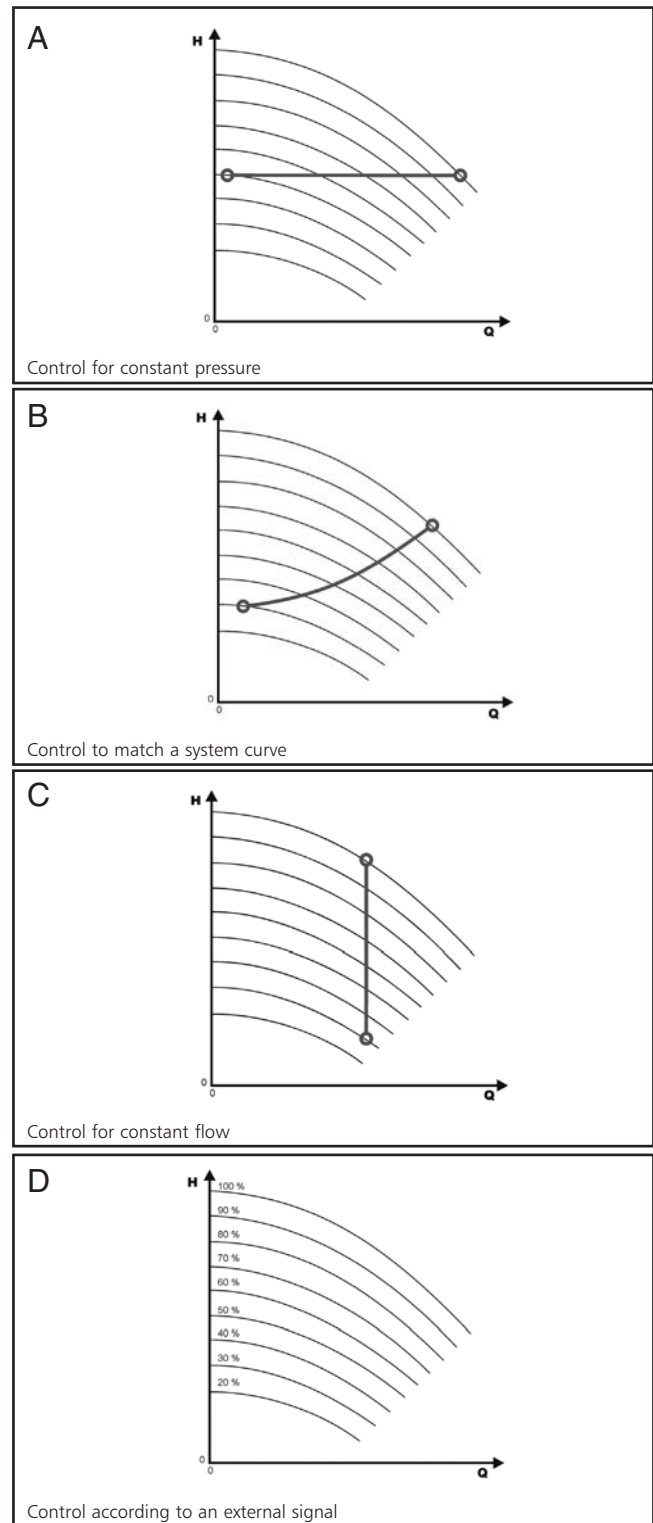

FCE-FCS SERIES
HYDRAULIC PERFORMANCE RANGE AT 50 Hz, 2 POLES

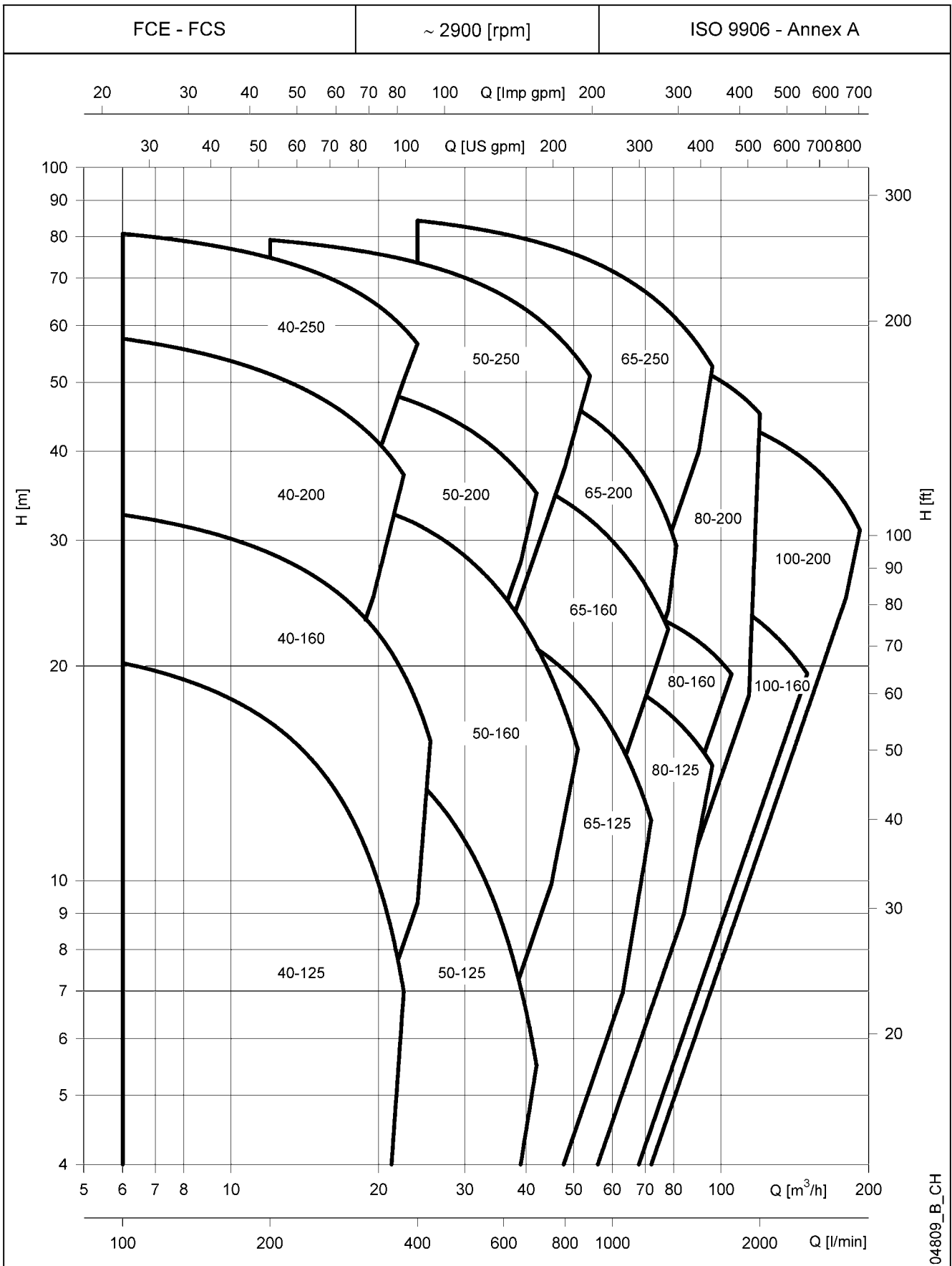

04809_B_CH

These performances are valid for liquids with density $\rho = 1,0 \text{ Kg/dm}^3$ and kinematic viscosity $\nu = 1 \text{ mm}^2/\text{sec}$.

FCE-FCS SERIES HYDRAULIC PERFORMANCE TABLE AT 50 Hz, 2 POLES

PUMP TYPE	RATED POWER		Q = DELIVERY																			
	kW	HP	V _{min} 0	100	200	350	375	400	600	700	800	850	1000	1200	1300	1500	1600	1750	1950	2500	3000	
			m ³ /h 0	6	12	21	22,5	24	36	42	48	51	60	72	78	90	96	105	117	150	180	
H = TOTAL HEAD METRES COLUMN OF WATER																						
40-125/07	0,75	1	17,1	15,1	11,8	3,6																
40-125/11	1,1	1,5	22,6	20,2	16,7	8,8	7,0															
40-160/15	1,5	2	27,3	24,7	20,9	13,1	11,3	9,3														
40-160/22	2,2	3	35,3	32,6	28,8	21,1	19,5	17,7														
40-200/*	*	*	42,5	38,9	34,0																	
40-200/40	4	5,5	51,0	46,9	41,7	30,6																
40-200/55	5,5	7,5	62,0	57,6	51,3	39,6	37,1															
40-250/75	7,5	10	75,4	71,1	65,0	52,9	50,3															
40-250/110	11	15	85,2	80,8	74,8	62,3	59,6	56,6														
50-125/11/A	1,1	1,5	15,3		13,5	11,1	10,6	10,1	5,4													
50-125/15/A	1,5	2	19,1		17,5	14,9	14,4	13,8	8,6	5,5												
50-160/22	2,2	3	26,1		23,9	21,1	20,5	20,0	14,7	11,6												
50-160/30	3	4	32,8		30,6	27,2	26,5	25,9	19,9	16,6	13,1											
50-160/40	4	5,5	38,1		36,1	32,9	32,3	31,6	25,1	21,3	17,3	15,3										
50-200/55	5,5	7,5	47,0		43,5	39,6	38,8	38,0	30,3													
50-200/75	7,5	10	56,0		52,0	48,2	47,5	46,7	39,4	34,9												
50-250/**	**	**	63,2		59,4	55,3	54,5	53,8	46,7	42,6	38,0											
50-250/110	11	15	69,4		65,3	61,3	60,6	59,8	53,2	49,4	45,0	42,5										
50-250/150	15	20	83,0		79,2	75,1	74,4	73,6	66,1	61,6	56,6	53,9										
65-125/22	2,2	3	18,8					16,4	14,3	13,0	11,4	10,6	7,9									
65-125/30	3	4	22,9					20,3	18,1	16,7	15,2	14,3	11,6									
65-125/40	4	5,5	26,6					24,4	22,4	21,1	19,7	18,9	16,3	12,1								
65-160/55	5,5	7,5	35,1					32,5	30,1	28,7	27,1	26,3	23,5	19,1								
65-160/75	7,5	10	42,4					40,0	37,4	35,8	34,0	33,1	29,9	25,2	22,5							
65-200/**	**	**	53,0					47,6	44,1	42,2	40,1	39,0	35,2	28,4	24,0							
65-200/110	11	15	61,0					55,2	51,3	49,3	47,1	45,9	42,1	35,8	31,8							
65-250/150	15	20	70,0					66,3	63,0	61,1	58,9	57,8	54,2	48,9	46,1	40,0						
65-250/185	18,5	25	80,0					75,2	71,8	69,9	67,7	66,6	63,0	57,6	54,6	47,9						
65-250/220	22	30	89,0					84,3	80,7	78,7	76,5	75,3	71,6	66,0	63,0	56,3	52,6					
80-125/30	3	4	15,5						14,5	14,1	13,6	13,3	12,3	10,7	9,9							
80-125/40	4	5,5	19,0						18,0	17,6	17,0	16,8	15,8	14,2	13,3	11,5						
80-125/55	5,5	7,5	23,0						21,5	21,0	20,5	20,2	19,3	18,0	17,2	15,5	14,5					
80-160/75	7,5	10	28,0						26,5	26,1	25,6	25,4	24,7	23,6	23,0	21,6	20,8	19,5				
80-200/110	11	15	41,0						37,0	36,2	35,2	34,7	33,2	30,7	29,3	26,2	24,5	21,5				
80-200/150	15	20	49,4						46,3	45,6	44,8	44,3	43,0	41,0	39,9	37,5	36,2	33,9	30,5			
80-200/185	18,5	25	56,9						53,4	52,6	51,7	51,2	49,8	47,9	46,9	44,7	43,5	41,4	38,1			
80-200/220	22	30	65,2						61,3	60,4	59,5	59,0	57,6	55,5	54,5	52,2	51,0	49,1	46,0			
100-160/110	11	15	29,0											28,0	27,3	26,9	25,9	25,4	24,6	23,4	19,5	
100-200/185	18,5	25	45,0												39,5	38,8	37,5	36,8	35,9	34,5	30,4	25,0
100-200/220	22	30	53,0												48,0	47,3	46,0	45,3	44,3	42,9	38,7	33,6

* FCE40-200/40A : 4 (kW) - 5.5 (HP)

FCS40-200/30 : 3 (kW) - 4 (HP)

fce-fcs-2p50-en_d_th

** FCE50-250/92 : 9.2 (kW) - 12.5 (HP)

FCS50-250/110A : 11 (kW) - 15 (HP)

FCE65-200/92 : 9.2 (kW) - 12.5 (HP)

FCS65-200/110A : 11 (kW) - 15 (HP)

Performances according to ISO 9906 - Annex A

**FCE4-FCS4 SERIES
HYDRAULIC PERFORMANCE RANGE AT 50 Hz, 4 POLES**

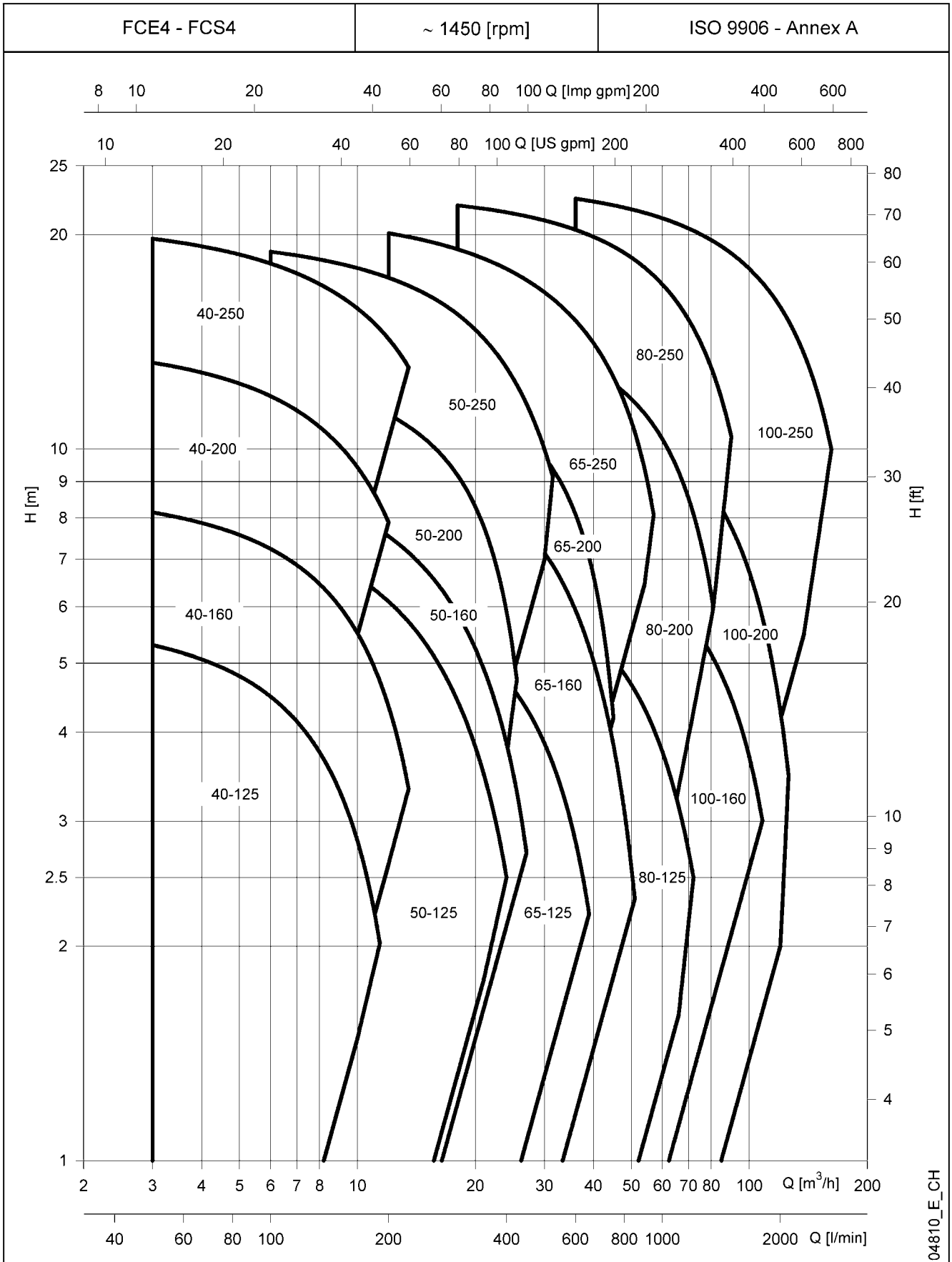

These performances are valid for liquids with density $\rho = 1,0 \text{ Kg/dm}^3$ and kinematic viscosity $\nu = 1 \text{ mm}^2/\text{sec}$.

FCE4-FCS4 SERIES

HYDRAULIC PERFORMANCE TABLE AT 50 Hz, 4 POLES

PUMP TYPE	RATED POWER		Q = DELIVERY																							
			l/min	50	100	150	175	200	300	350	400	500	600	650	750	900	1100	1200	1500	1800	2000	2500				
			m ³ /h	3	6	9	10,5	12	18	21	24	30	36	39	45	54	66	72	90	108	120	150				
kW		HP	H = TOTAL HEAD METRES COLUMN OF WATER																							
40-125/02A *	0,25	0,33	4,7	4,1	3,3	2,0																				
40-125/02 *	0,25	0,33	5,9	5,3	4,5	3,3	2,5																			
40-160/02 *	0,25	0,33	7,1	6,4	5,5	4,3	3,6	2,6																		
40-160/03 *	0,37	0,5	8,9	8,1	7,2	6,0	5,2	4,4																		
40-200/05	0,55	0,75	12,4	11,4	10,1	8,2	7,1																			
40-200/07	0,75	1	14,2	13,2	11,9	10,1	9,1	7,9																		
40-250/11	1,1	1,5	18,6	17,3	15,7	13,9	12,8	11,6																		
40-250/15	1,5	2	21,0	19,8	18,2	16,4	15,4	14,3																		
50-125/02 *	0,25	0,33	6,2		5,5	5,0	4,6	4,3	2,7	1,8																
50-125/03 *	0,37	0,5	8,0		7,4	6,8	6,5	6,1	4,4	3,5	2,5															
50-160/05 *	0,55	0,75	9,4		8,8	8,2	7,9	7,5	5,9	4,9	3,9															
50-200/07	0,75	1	11,4		10,5	9,9	9,5	9,1	7,1	5,6	3,7															
50-200/11	1,1	1,5	13,6		12,6	12,0	11,6	11,2	9,2	7,8	5,9															
50-250/15	1,5	2	17,0		15,9	15,2	14,8	14,4	12,5	11,4	10,1	7,0														
50-250/22	2,2	3	20,2		18,9	18,2	17,8	17,4	15,5	14,3	13,0	10,0														
65-125/03 *	0,37	0,5	5,6					4,9	4,3	3,9	3,5	2,6														
65-125/05 *	0,55	0,75	6,7					5,9	5,4	5,1	4,7	3,9	2,8	2,2												
65-160/07	0,75	1	8,6					7,8	7,2	6,8	6,4	5,4	4,3	3,7	2,4											
65-160/11	1,1	1,5	10,4					9,7	9,0	8,6	8,2	7,2	5,9	5,3	3,8											
65-200/15	1,5	2	14,7					13,2	12,1	11,6	11,0	9,7	8,1	7,0	4,2											
65-250/22	2,2	3	19,0					17,6	16,6	16,0	15,4	14,1	12,7	11,9	10,1	6,5										
65-250/30	3	4	21,4					20,1	19,1	18,5	17,9	16,6	15,2	14,4	12,6	9,4										
80-125/07	0,75	1	5,6						5,2	5,1	5,0	4,6	4,3	4,1	3,6	2,8	1,6									
80-125/11	1,1	1,5	6,8						6,4	6,3	6,2	6,0	5,7	5,5	5,1	4,3	3,1	2,5								
80-200/15	1,5	2	10,5						9,6	9,4	9,2	8,7	8,1	7,8	7,1	5,8	3,3									
80-200/22	2,2	3	13,7						12,7	12,5	12,3	11,9	11,3	11,0	10,3	9,0	6,8	5,4								
80-200/30	3	4	15,8						14,7	14,5	14,3	13,8	13,3	13,0	12,4	11,2	9,3	8,1								
80-250/40	4	5,5	19,9						18,7	18,5	18,2	17,7	17,0	16,7	15,9	14,6	12,5	11,2								
80-250/55	5,5	7,5	23,2						22,0	21,8	21,5	21,0	20,3	20,0	19,3	18,0	16,0	14,8	10,4							
100-160/15	1,5	2	7,8									7,4	7,2	7,1	6,9	6,5	6,0	5,6	4,5	3,0						
100-200/22	2,2	3	10,5										9,3	9,2	8,9	8,3	7,5	7,1	5,4	3,5	2,0					
100-200/30	3	4	12,8											11,5	11,4	11,1	10,6	9,8	9,3	7,8	5,8	4,3				
100-250/40	4	5,5	17,0												15,5	15,3	14,9	14,3	13,4	12,9	11,2	9,2	7,8			
100-250/55	5,5	7,5	20,5													19,0	18,8	18,4	17,8	17,0	16,5	14,9	13,1	11,8	8,0	
100-250/75	7,5	10	24,0														22,5	22,3	22,0	21,5	20,7	20,3	18,8	17,1	15,8	11,9

* FCE4 VERSION ONLY

fce4-fcs4-4p50-en_f_th

Performances according to ISO 9906 - Annex A

**FCS4 SERIES
HYDRAULIC PERFORMANCE RANGE AT 50 Hz, 4 POLES**

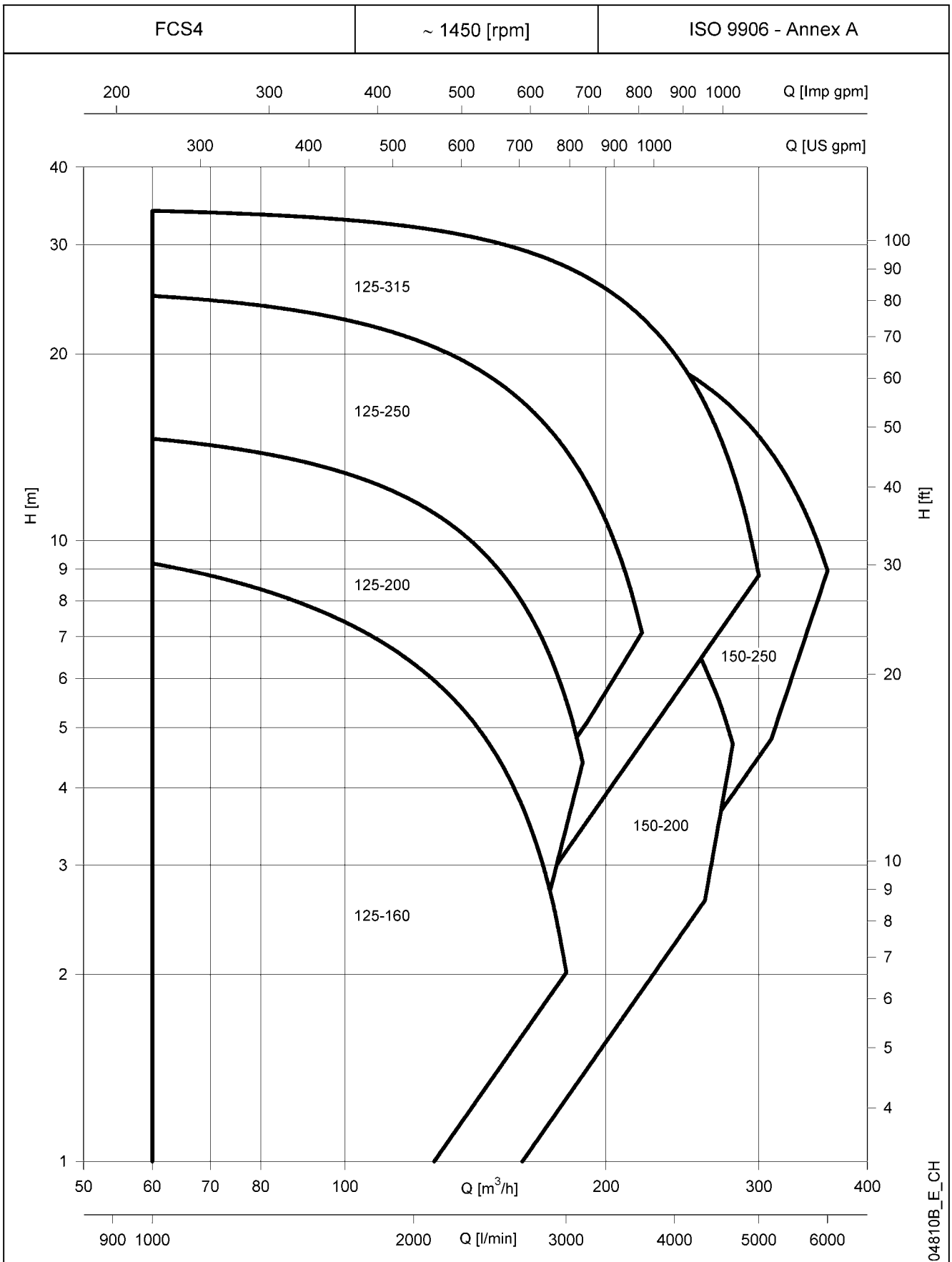

04810B_E_CH

These performances are valid for liquids with density $\rho = 1,0 \text{ Kg/dm}^3$ and kinematic viscosity $\nu = 1 \text{ mm}^2/\text{sec}$.

FCS4 SERIES

HYDRAULIC PERFORMANCE TABLE AT 50 Hz, 4 POLES

PUMP TYPE	RATED POWER		Q = DELIVERY																	
			l/min	1000	1083	1167	1333	1500	1667	2000	2333	2667	3000	3333	3667	4167	4667	5000	5333	5500
	m ³ /h	60	65	70	80	90	100	120	140	160	180	200	220	250	280	300	320	330		
kW		HP	H = TOTAL HEAD METRES COLUMN OF WATER																	
125-160/30	3	4	10,5	9,2	9,0	8,8	8,3	7,9	7,4	6,3	5,2	3,7	2,0							
125-200/40	4	5,5	12,7	11,5	11,3	11,0	10,5	9,9	9,3	7,7	5,7	3,4								
125-200/55	5,5	7,5	15,6	14,6	14,4	14,3	13,9	13,4	12,9	11,6	10,0	8,0	5,5							
125-250/75	7,5	10	20,5	19,1	18,9	18,6	18,1	17,4	16,6	14,7	12,4	9,6	6,7							
125-250/110	11	15	26,1	24,8	24,6	24,4	23,9	23,4	22,7	21,1	19,2	16,8	14,0	10,7	7,1					
125-315/150	15	20	27,0	26,0	25,9	25,7	25,4	25,0	24,6	23,5	22,1	20,4	18,3	15,9	12,9	7,8				
125-315/185	18,5	25	31,0	30,0	29,9	29,8	29,5	29,2	28,9	28,0	26,7	25,1	23,1	20,7	18,0	13,3	8,0			
125-315/220	22	30	35,0	34,0	33,9	33,8	33,6	33,3	32,9	32,1	30,9	29,5	27,6	25,5	22,9	18,4	12,9	8,8		
150-200/55	5,5	7,5	12,0	10,5	10,4	10,2	9,9	9,6	9,3	8,6	7,9	7,2	6,4	5,7	4,8	3,2				
150-200/75	7,5	10	16,0	14,8	14,6	14,4	14,1	13,7	13,4	12,6	11,9	11,1	10,3	9,5	8,6	6,9	4,7			
150-250/110	11	15	18,4					17,8	17,6	17,0	16,3	15,5	14,6	13,5	12,3	10,2	7,7	5,8		
150-250/150	15	20	22,4					22,0	21,8	21,3	20,7	20,0	19,3	18,4	17,4	15,6	13,3	11,5	9,5	8,3
150-250/185	18,5	25	25,1					24,7	24,6	24,1	23,6	23,0	22,2	21,3	20,3	18,5	16,4	14,7	13,0	12,0

Performances according to ISO 9906 - Annex A

fcs4-4p50-en_d_th

**FCE-FCS SERIES
OPERATING CHARACTERISTICS AT 50 Hz, 2 POLES**

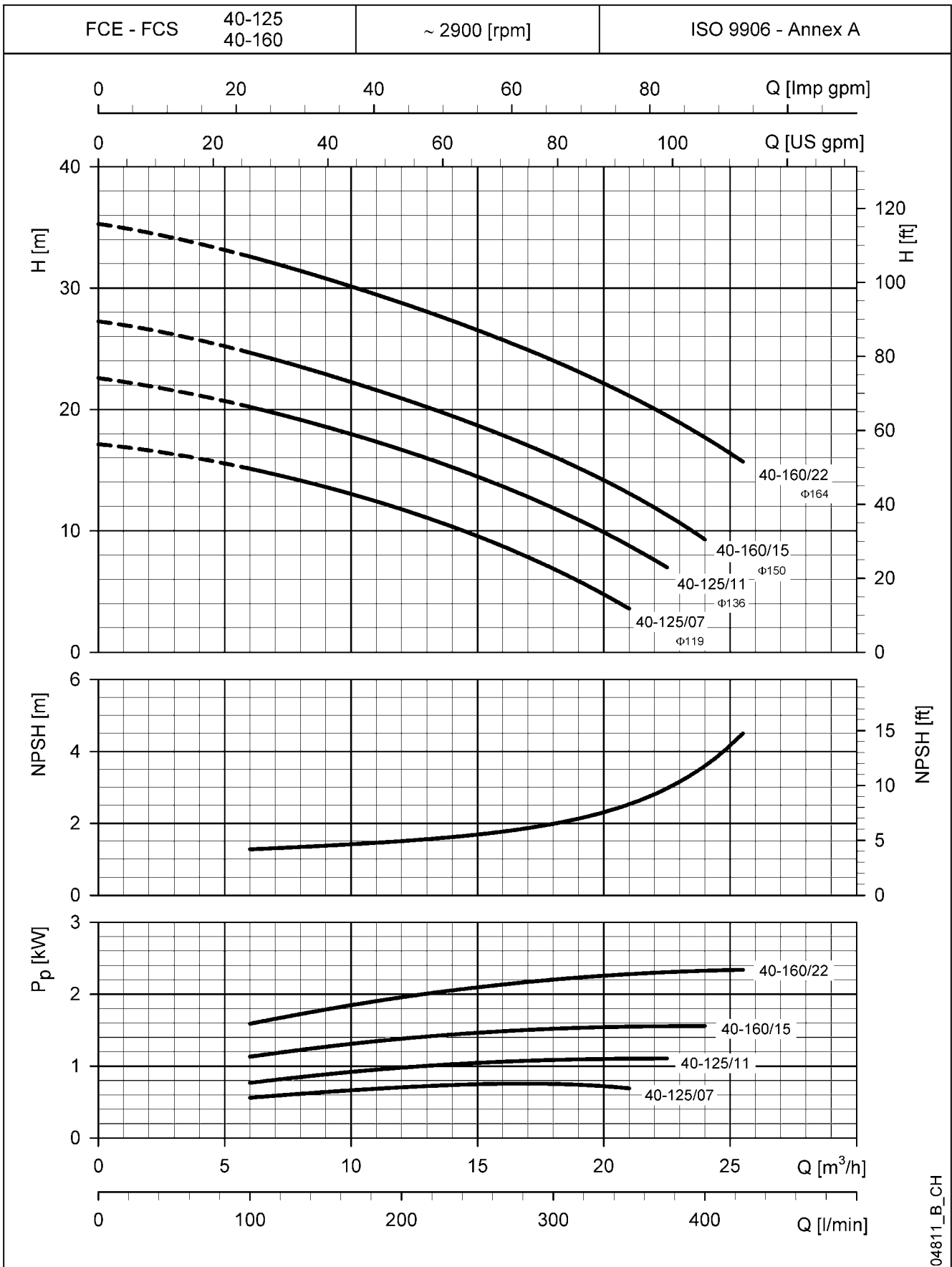

04811_B_CH

The NPSH values are laboratory values; for practical use we suggest increasing these values by 0,5 m.
These performances are valid for liquids with density $\rho = 1,0 \text{ Kg/dm}^3$ and kinematic viscosity $\nu = 1 \text{ mm}^2/\text{sec}$.

**FCE-FCS SERIES
OPERATING CHARACTERISTICS AT 50 Hz, 2 POLES**

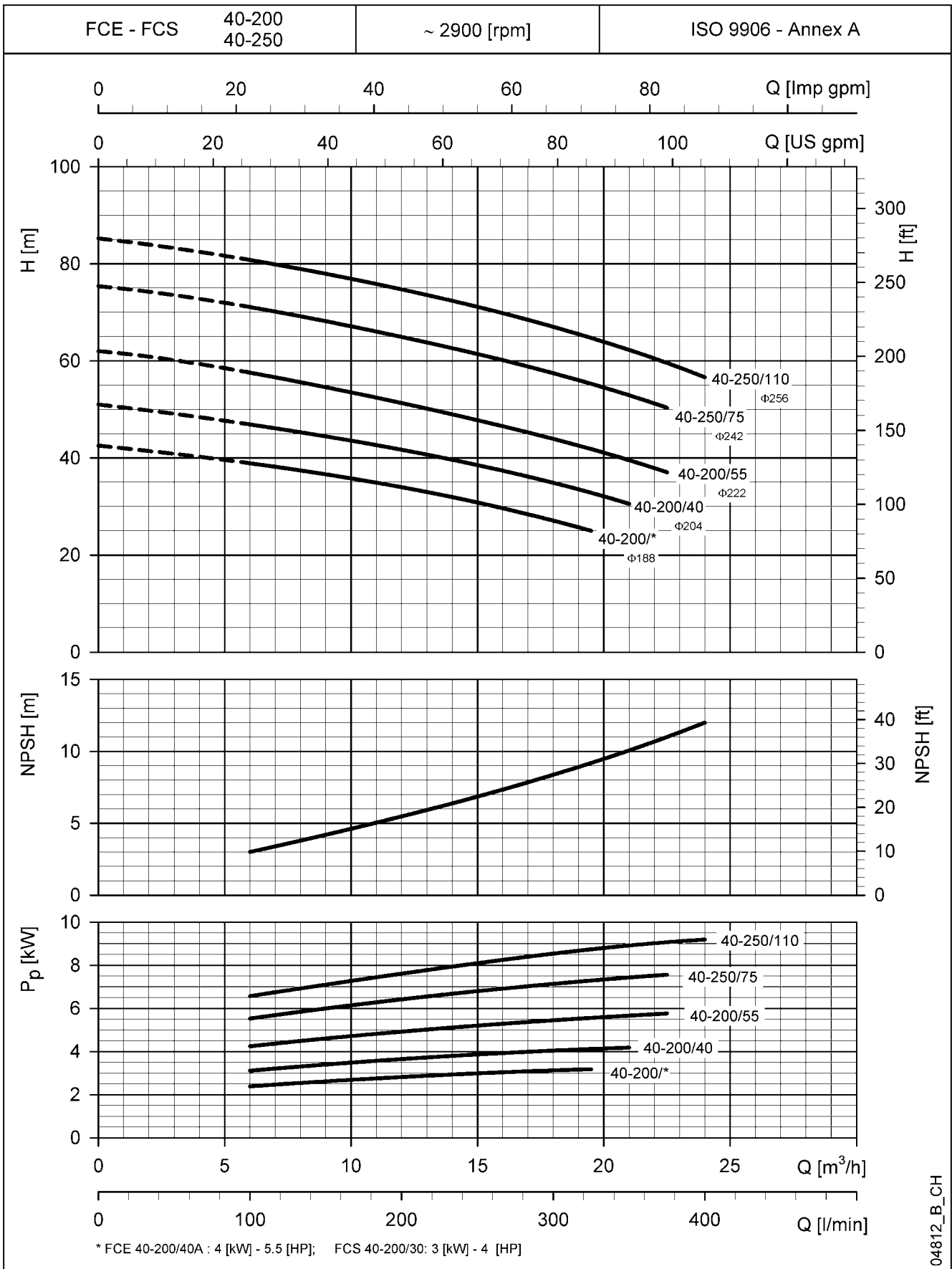

04812_B_CH

The NPSH values are laboratory values; for practical use we suggest increasing these values by 0,5 m.
These performances are valid for liquids with density $\rho = 1,0 \text{ Kg/dm}^3$ and kinematic viscosity $\nu = 1 \text{ mm}^2/\text{sec}$.

FCE-FCS SERIES OPERATING CHARACTERISTICS AT 50 Hz, 2 POLES

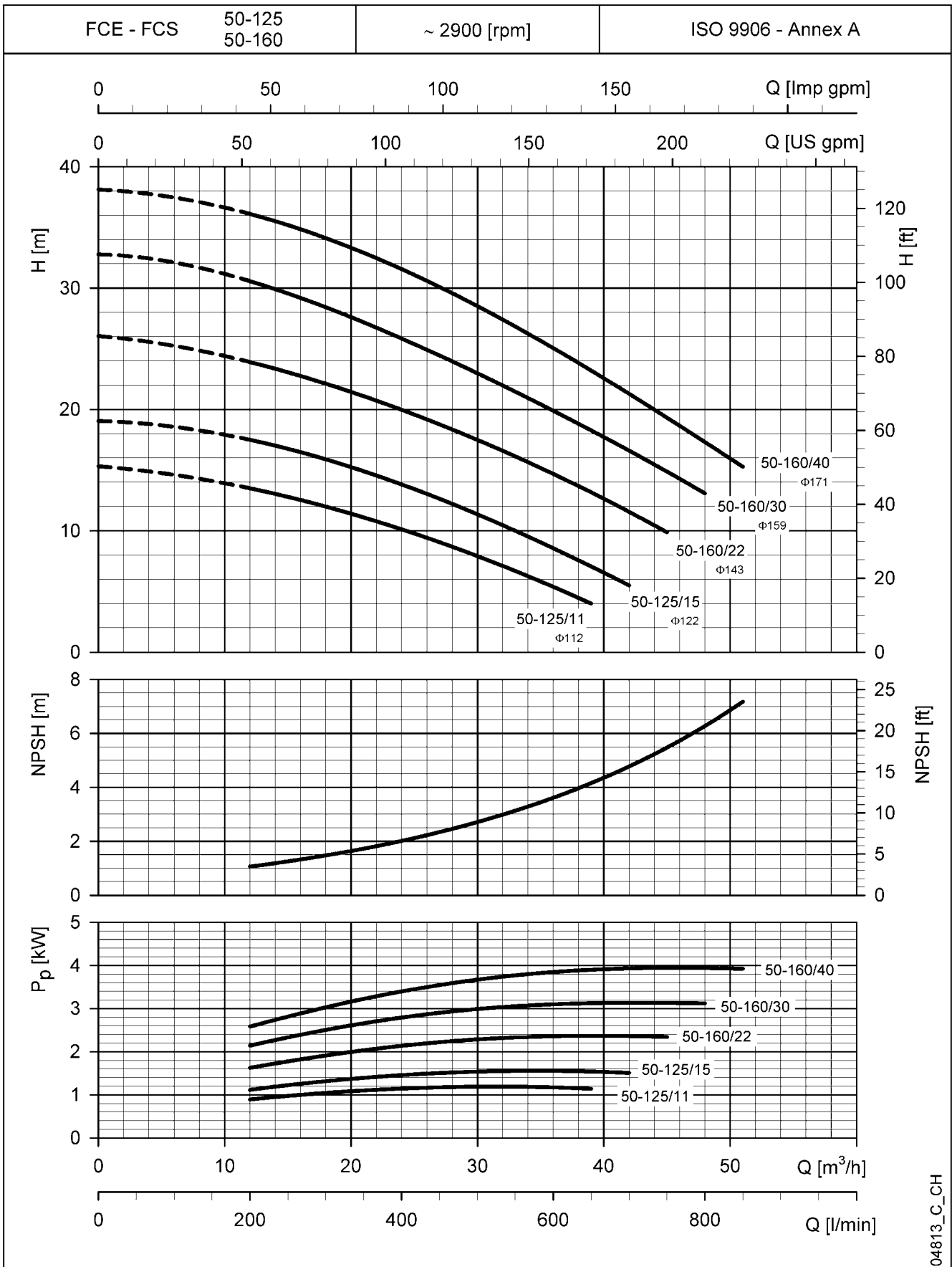

04813_C_CH

The NPSH values are laboratory values; for practical use we suggest increasing these values by 0,5 m.
 These performances are valid for liquids with density $\rho = 1,0 \text{ Kg/dm}^3$ and kinematic viscosity $\nu = 1 \text{ mm}^2/\text{sec}$.

**FCE-FCS SERIES
OPERATING CHARACTERISTICS AT 50 Hz, 2 POLES**

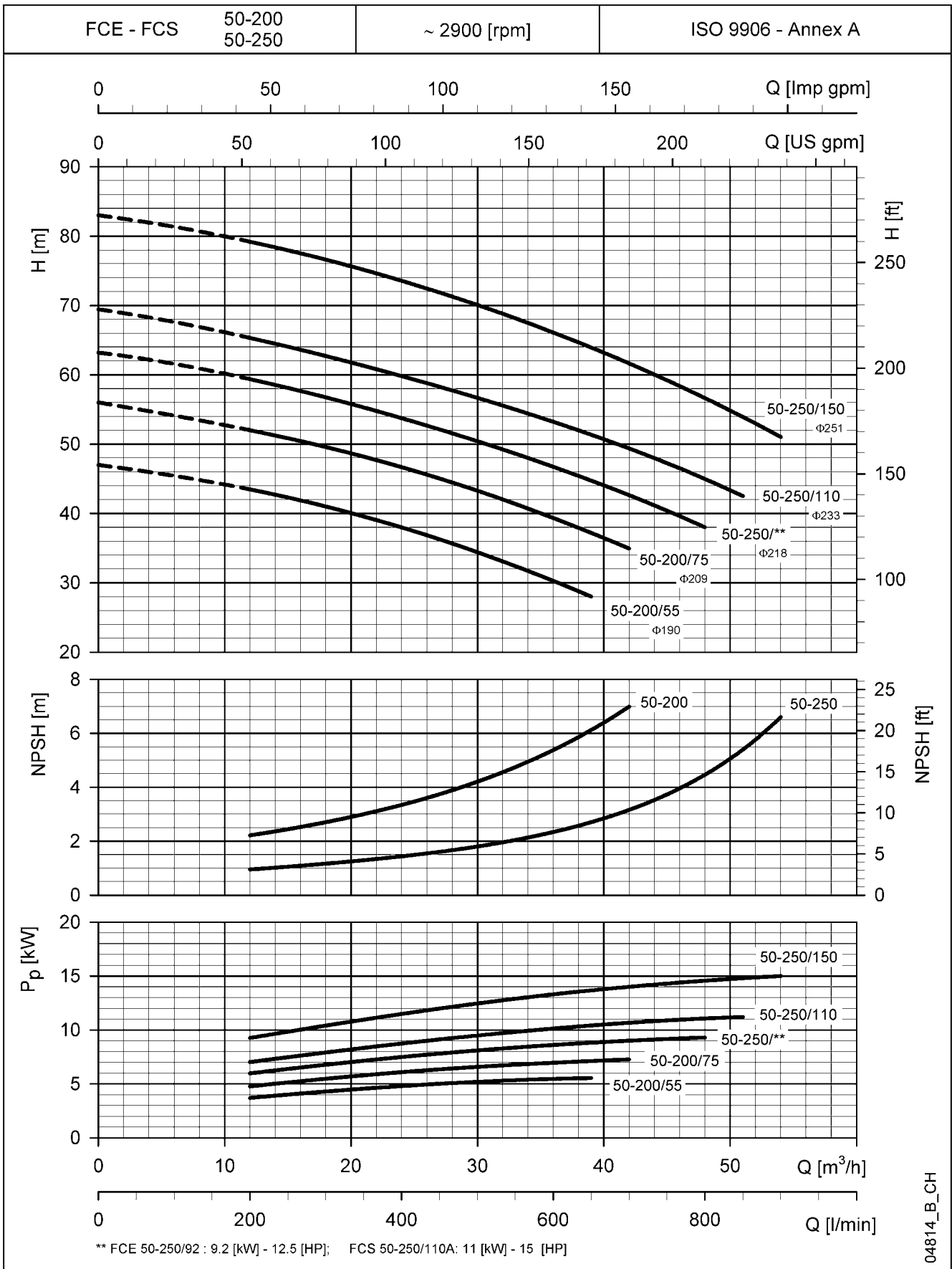

04814_B_CH

The NPSH values are laboratory values; for practical use we suggest increasing these values by 0,5 m.
These performances are valid for liquids with density $\rho = 1,0 \text{ Kg/dm}^3$ and kinematic viscosity $\nu = 1 \text{ mm}^2/\text{sec}$.

FCE-FCS SERIES OPERATING CHARACTERISTICS AT 50 Hz, 2 POLES

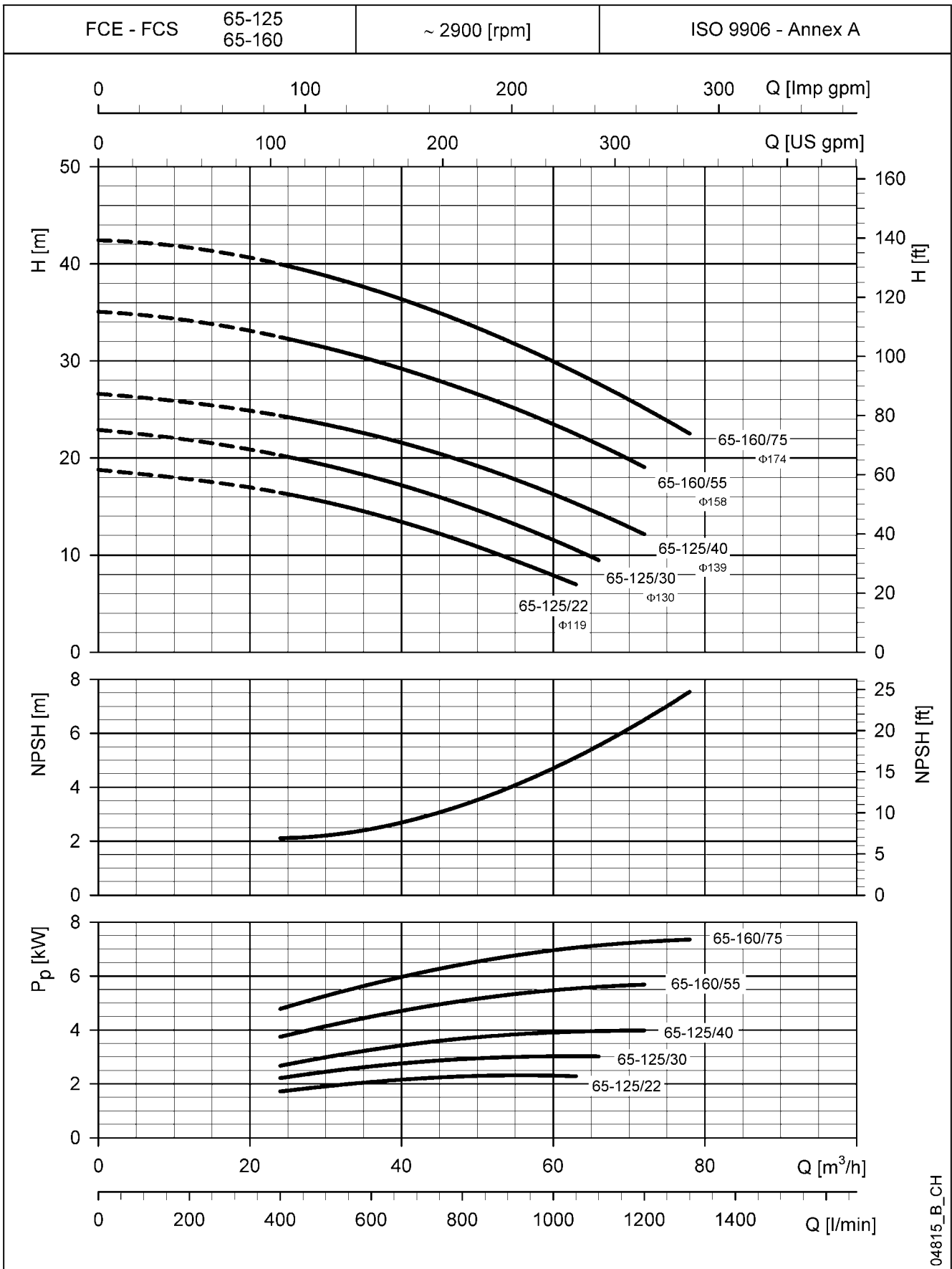

04815_B_CH

The NPSH values are laboratory values; for practical use we suggest increasing these values by 0,5 m.
 These performances are valid for liquids with density $\rho = 1,0 \text{ Kg/dm}^3$ and kinematic viscosity $\nu = 1 \text{ mm}^2/\text{sec}$.

**FCE-FCS SERIES
OPERATING CHARACTERISTICS AT 50 Hz, 2 POLES**

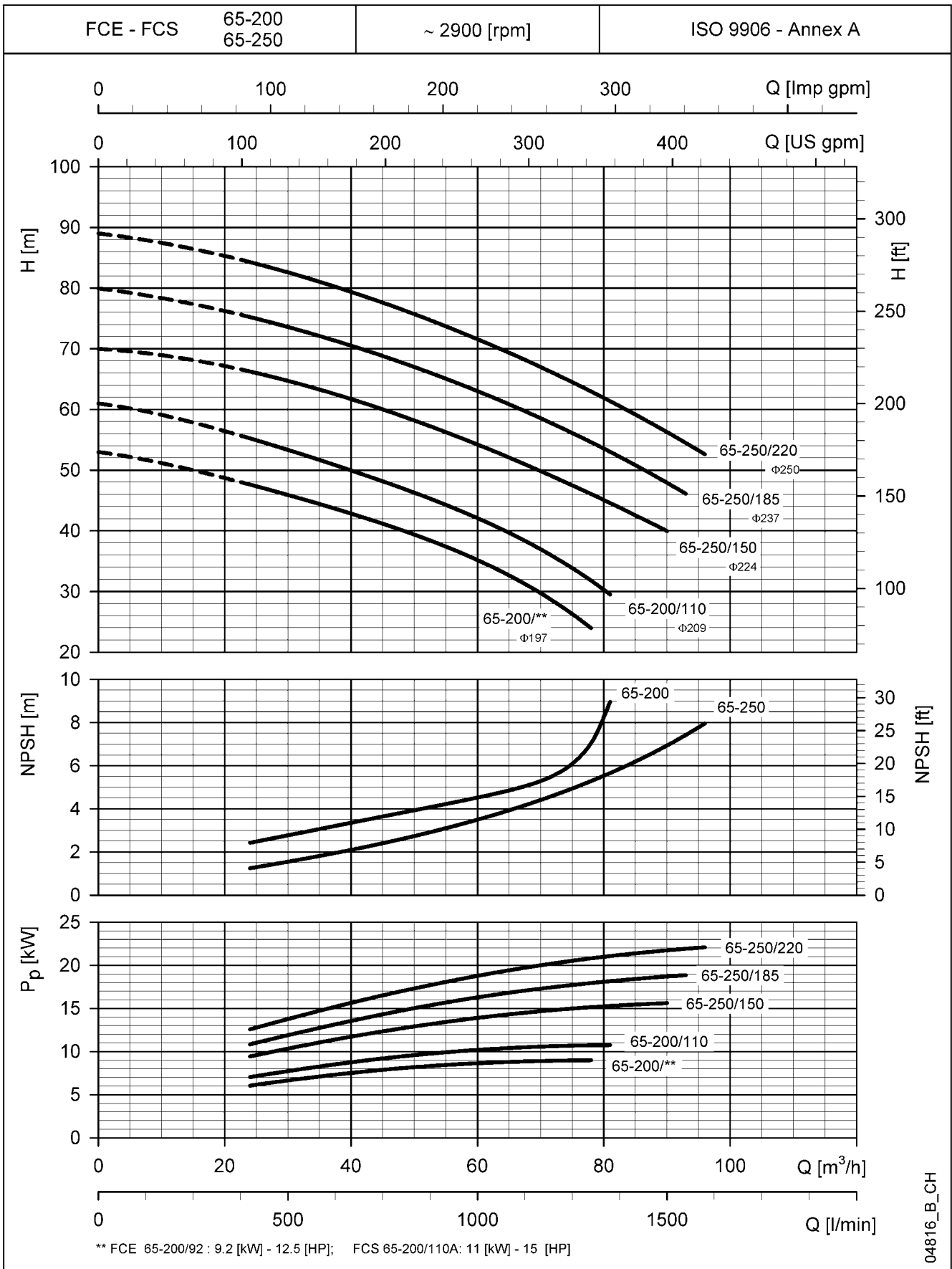

The NPSH values are laboratory values; for practical use we suggest increasing these values by 0,5 m.
These performances are valid for liquids with density $\rho = 1,0 \text{ Kg/dm}^3$ and kinematic viscosity $\nu = 1 \text{ mm}^2/\text{sec}$.

FCE-FCS SERIES
OPERATING CHARACTERISTICS AT 50 Hz, 2 POLES

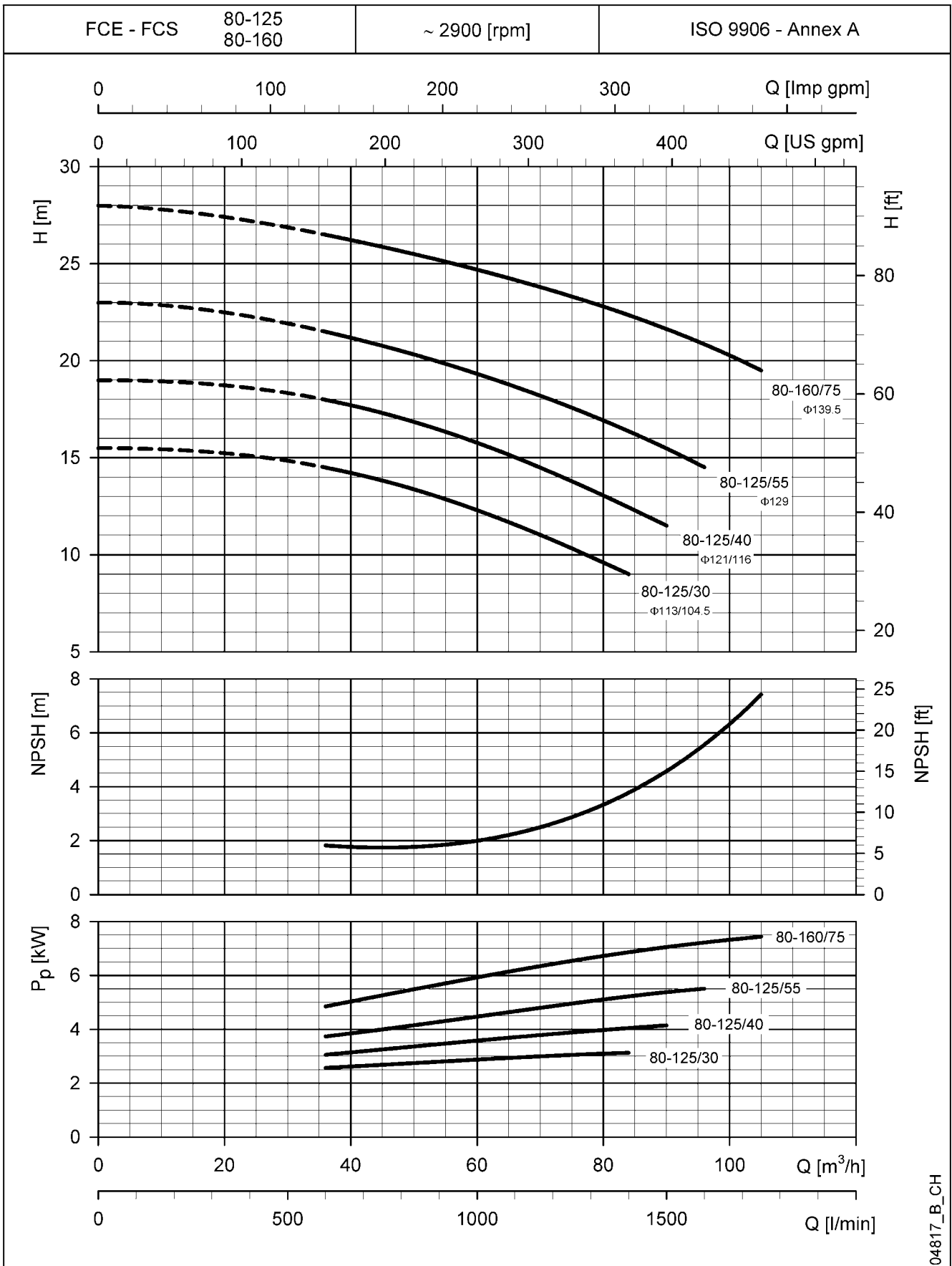

04817_B_CH

The NPSH values are laboratory values; for practical use we suggest increasing these values by 0,5 m.
These performances are valid for liquids with density $\rho = 1,0 \text{ Kg/dm}^3$ and kinematic viscosity $\nu = 1 \text{ mm}^2/\text{sec}$.

**FCE-FCS SERIES
OPERATING CHARACTERISTICS AT 50 Hz, 2 POLES**

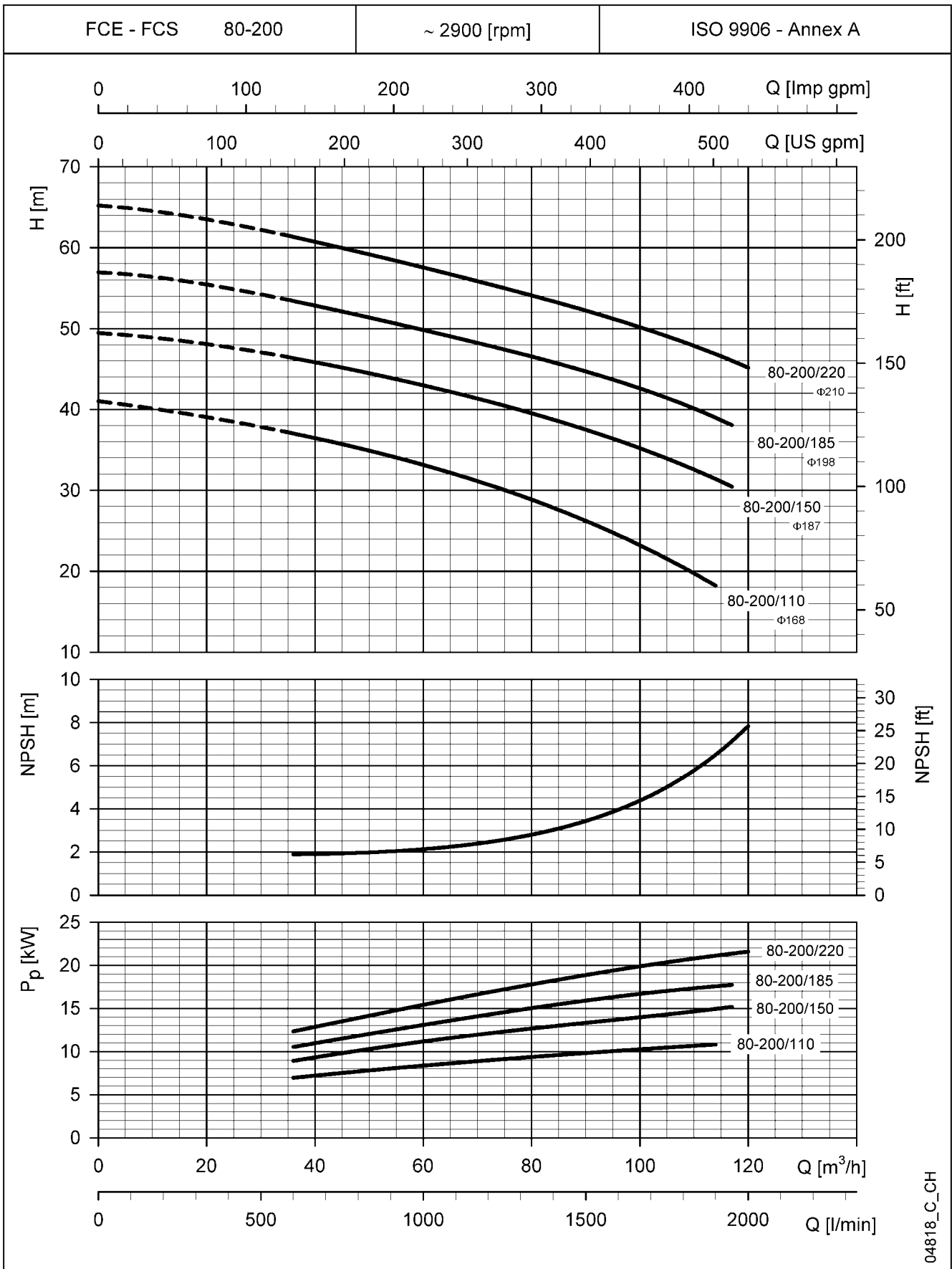

04818_C_CH

The NPSH values are laboratory values; for practical use we suggest increasing these values by 0,5 m.
These performances are valid for liquids with density $\rho = 1,0 \text{ Kg/dm}^3$ and kinematic viscosity $\nu = 1 \text{ mm}^2/\text{sec}$.

**FCE-FCS SERIES
OPERATING CHARACTERISTICS AT 50 Hz, 2 POLES**

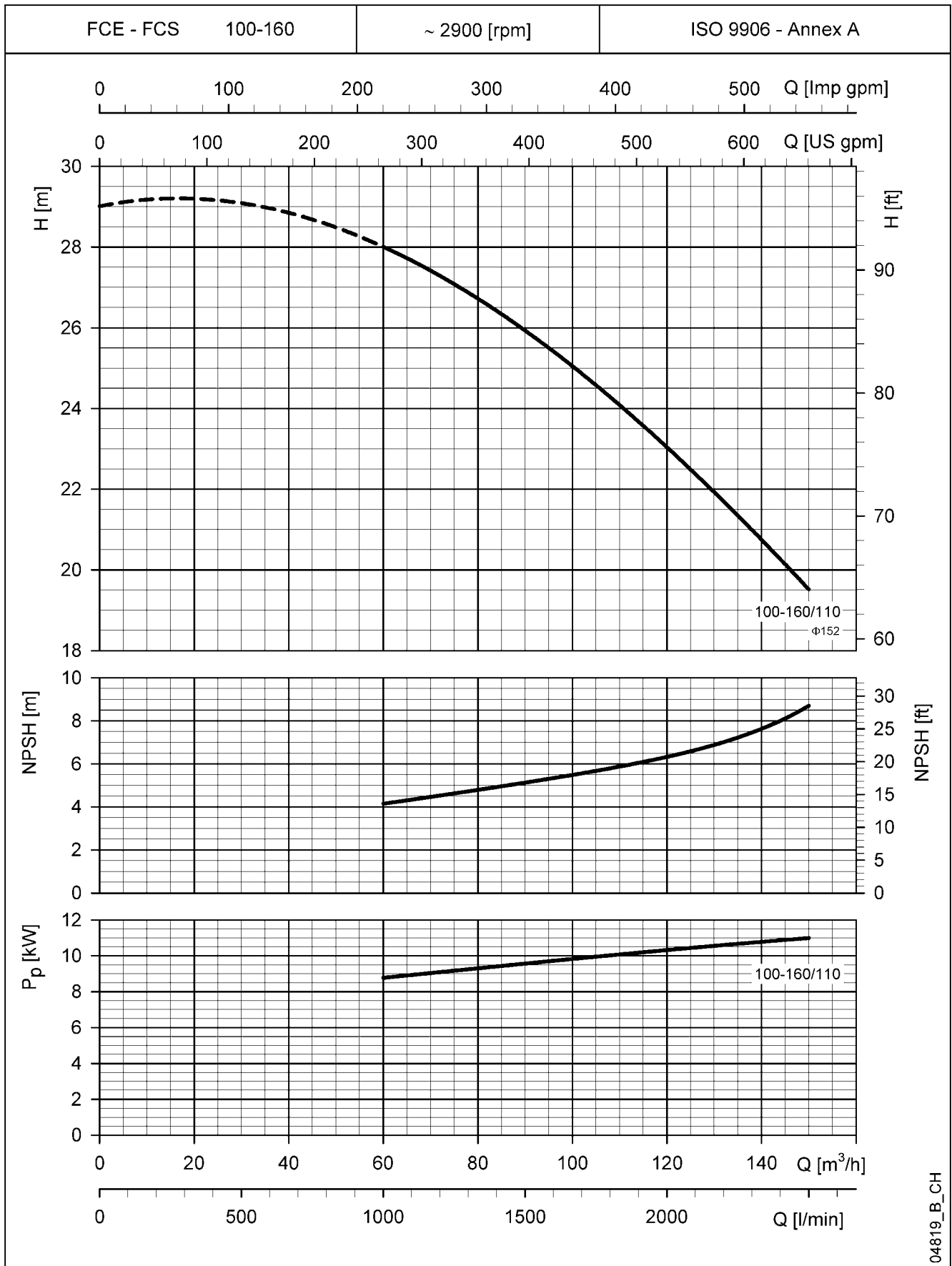

The NPSH values are laboratory values; for practical use we suggest increasing these values by 0,5 m.
These performances are valid for liquids with density $\rho = 1,0 \text{ Kg/dm}^3$ and kinematic viscosity $\nu = 1 \text{ mm}^2/\text{sec}$.

**FCE-FCS SERIES
OPERATING CHARACTERISTICS AT 50 Hz, 2 POLES**

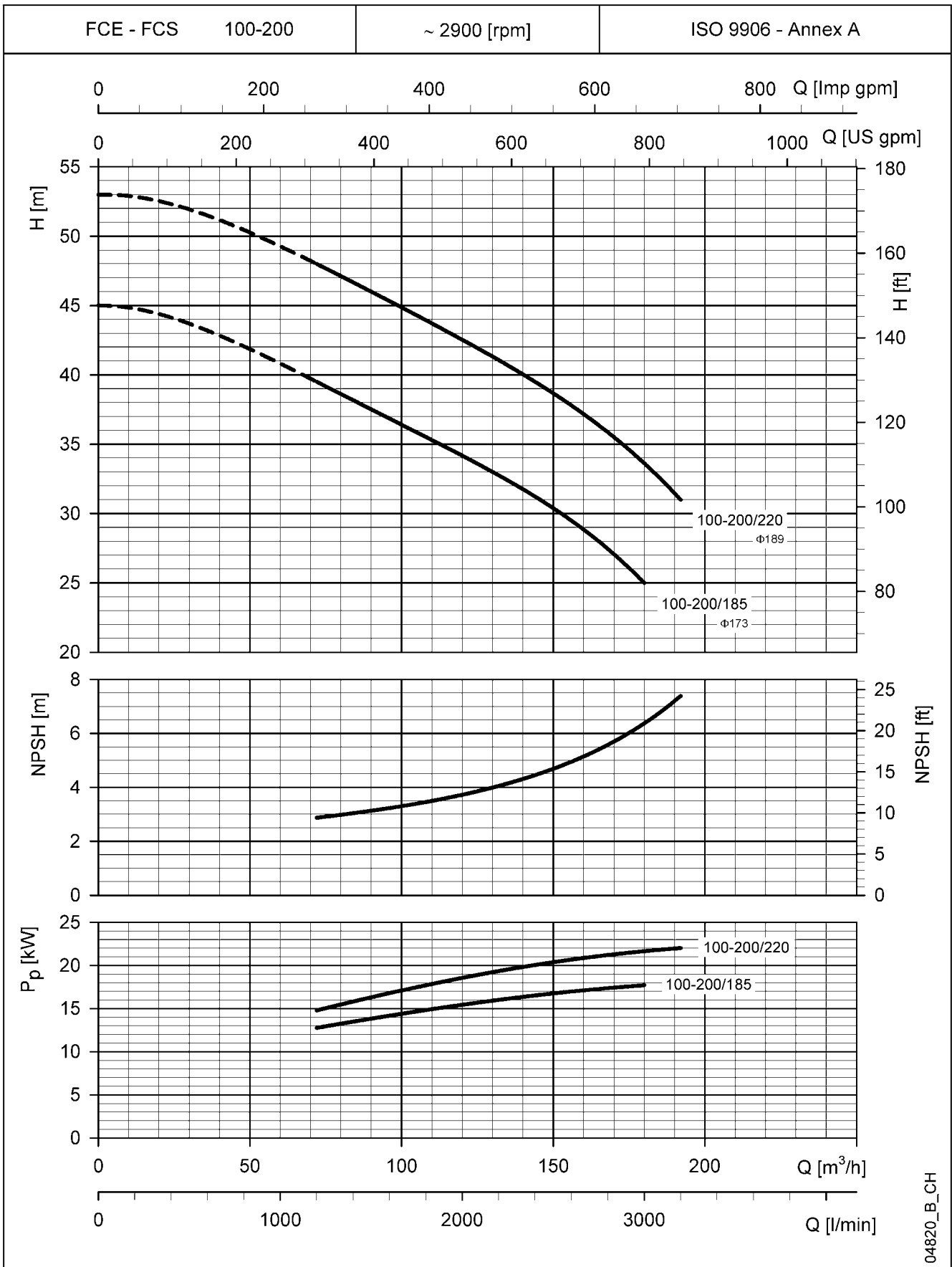

The NPSH values are laboratory values; for practical use we suggest increasing these values by 0,5 m.
These performances are valid for liquids with density $\rho = 1,0 \text{ Kg/dm}^3$ and kinematic viscosity $\nu = 1 \text{ mm}^2/\text{sec}$.

**FCE4 SERIES
OPERATING CHARACTERISTICS AT 50 Hz, 4 POLES**

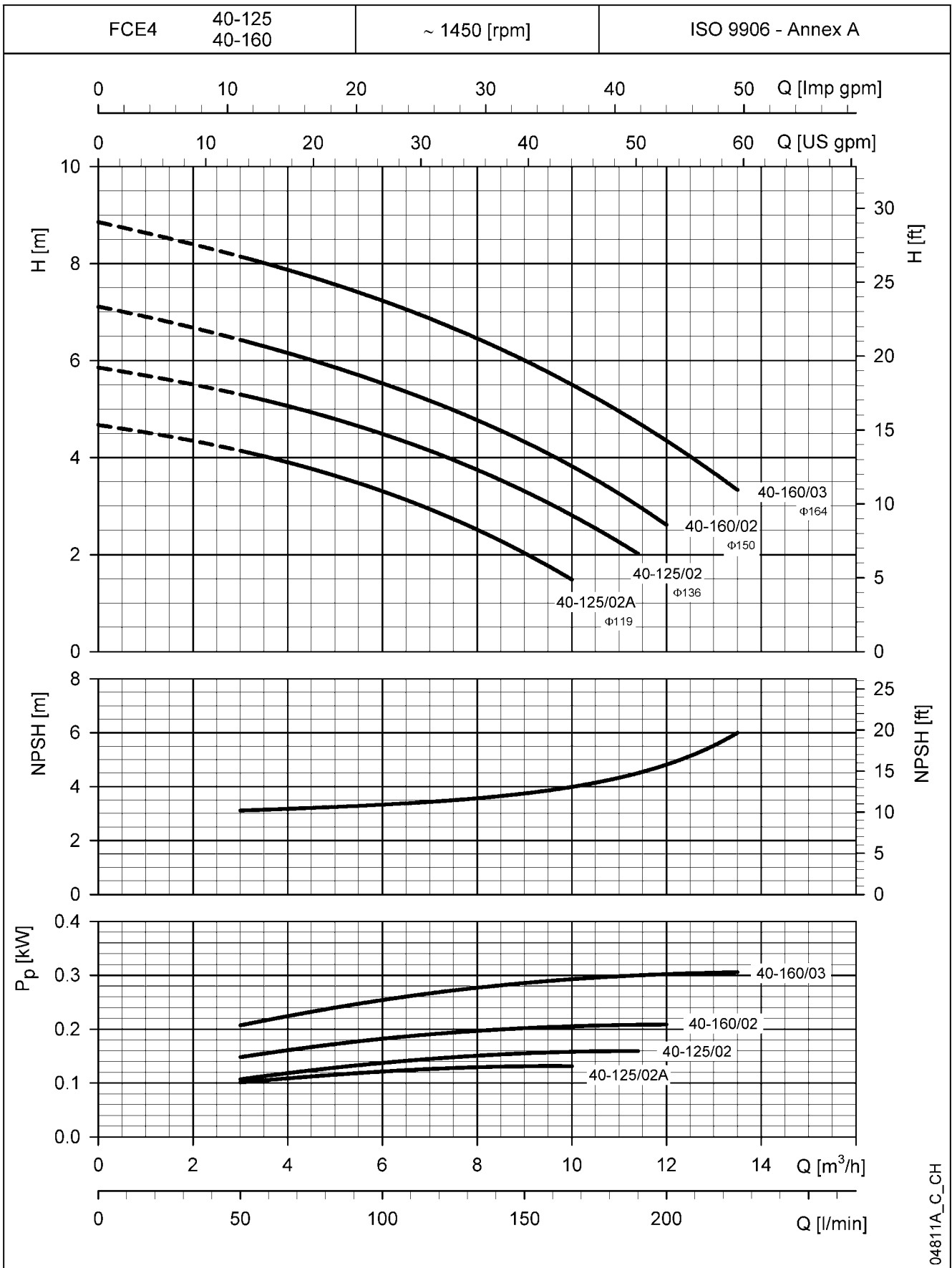

04811A_C_CH

The NPSH values are laboratory values; for practical use we suggest increasing these values by 0,5 m.
These performances are valid for liquids with density $\rho = 1,0 \text{ Kg/dm}^3$ and kinematic viscosity $\nu = 1 \text{ mm}^2/\text{sec}$.

**FCE4-FCS4 SERIES
OPERATING CHARACTERISTICS AT 50 Hz, 4 POLES**

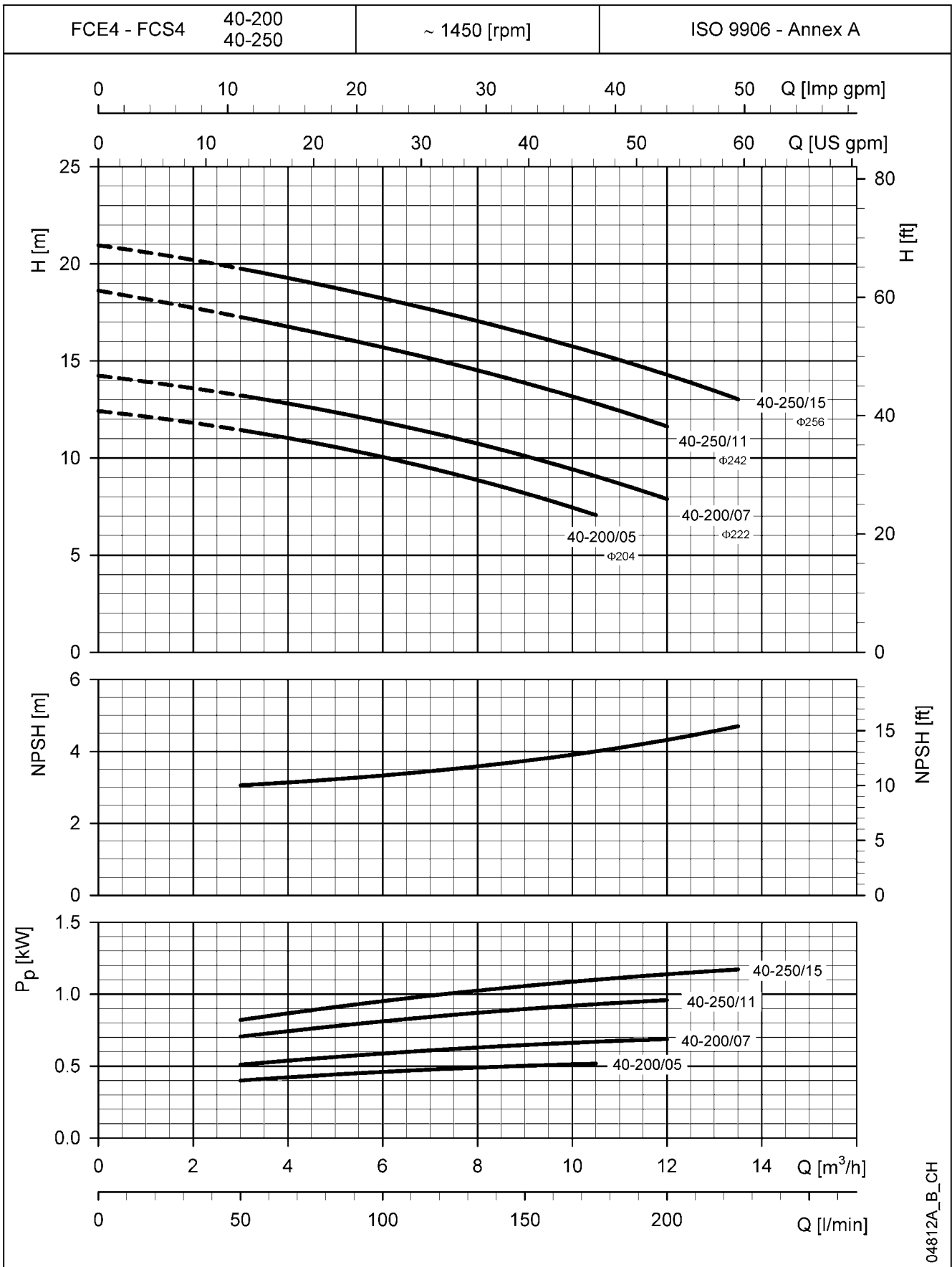

04812A_B_CH

The NPSH values are laboratory values; for practical use we suggest increasing these values by 0,5 m.
These performances are valid for liquids with density $\rho = 1,0 \text{ Kg/dm}^3$ and kinematic viscosity $\nu = 1 \text{ mm}^2/\text{sec}$.

**FCE4 SERIES
OPERATING CHARACTERISTICS AT 50 Hz, 4 POLES**

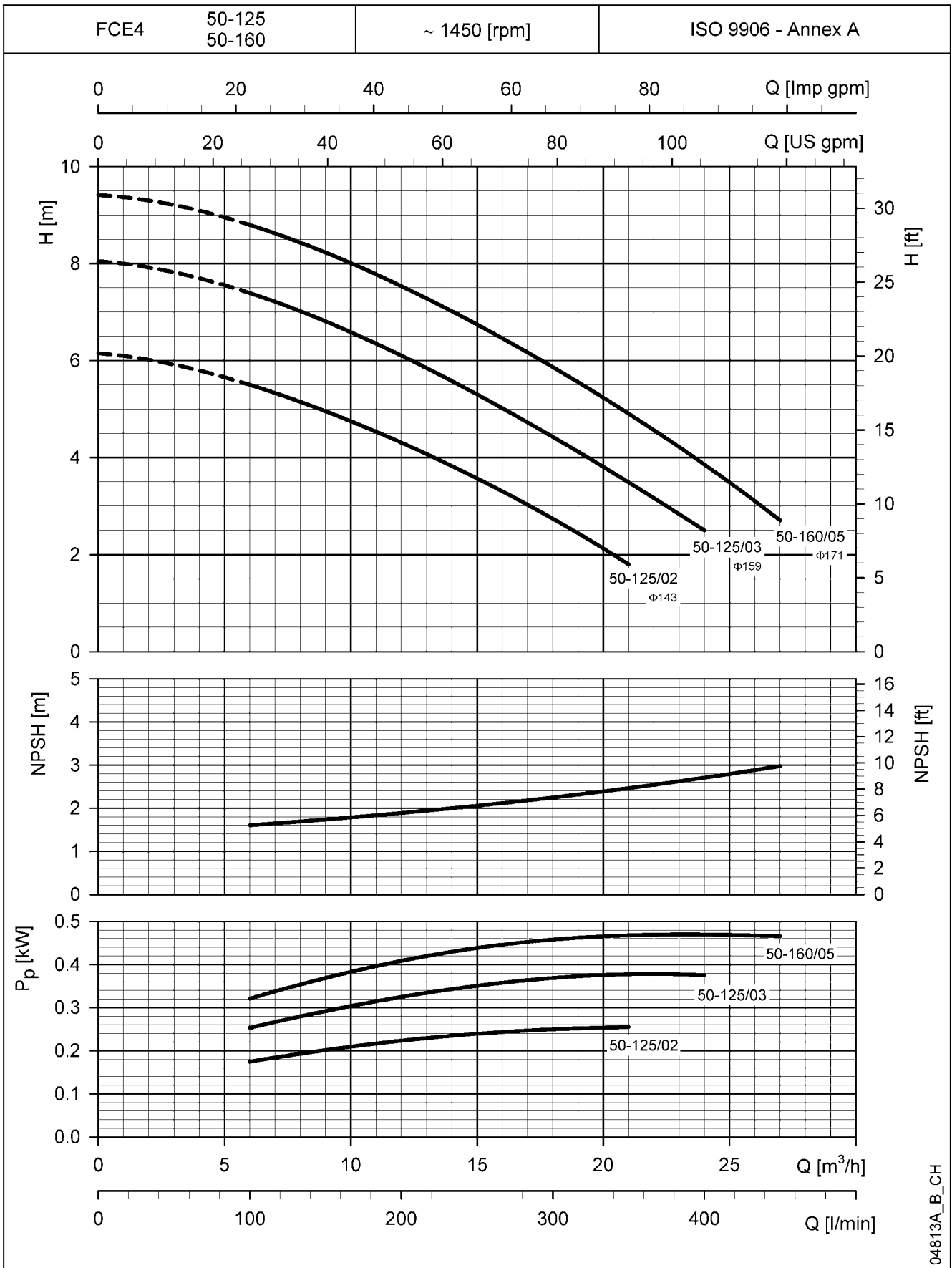

04813A_B_CH

The NPSH values are laboratory values; for practical use we suggest increasing these values by 0,5 m.
These performances are valid for liquids with density $\rho = 1,0 \text{ Kg/dm}^3$ and kinematic viscosity $\nu = 1 \text{ mm}^2/\text{sec}$.

FCE4-FCS4 SERIES OPERATING CHARACTERISTICS AT 50 Hz, 4 POLES

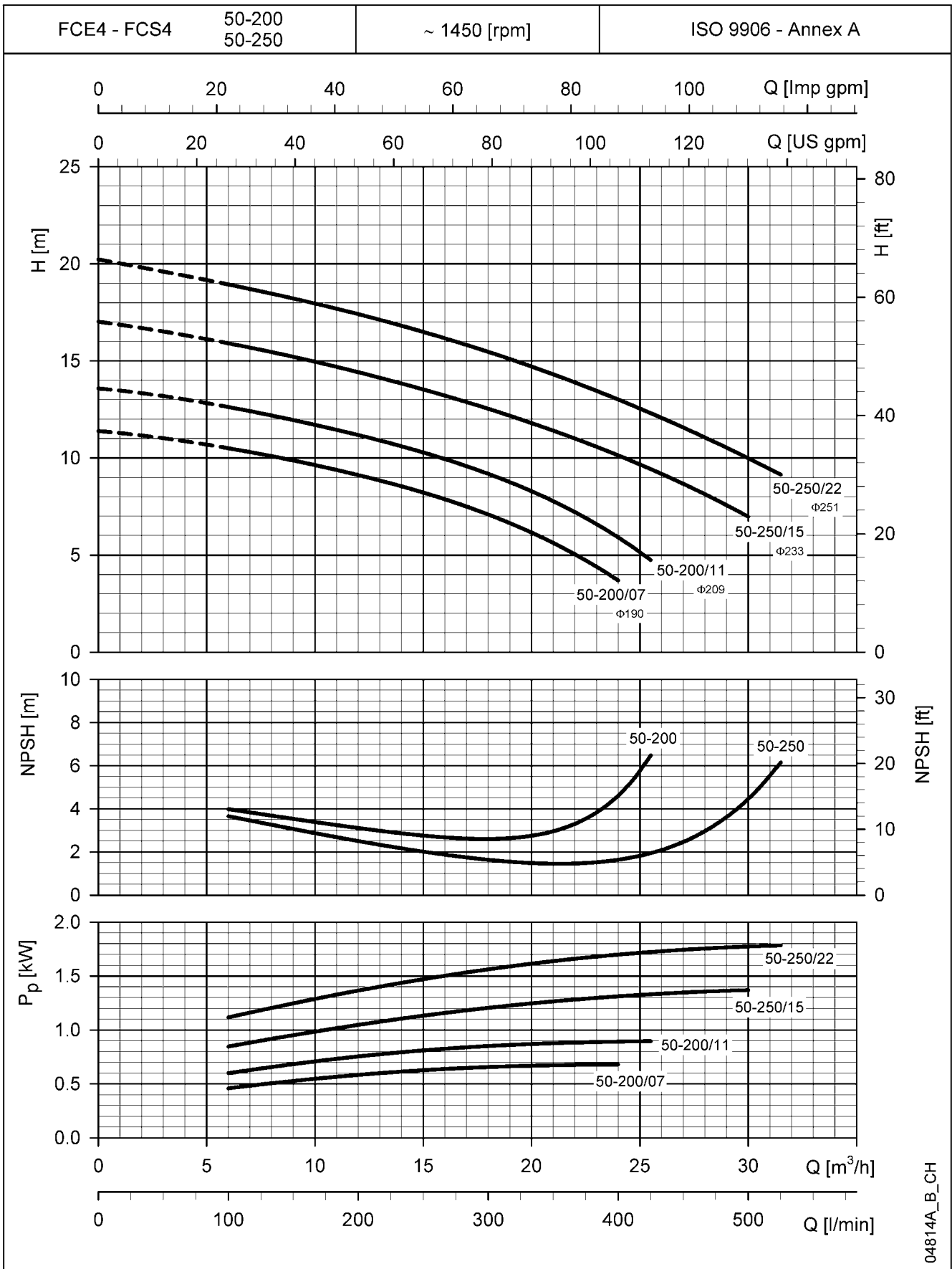

04814A_B_CH

The NPSH values are laboratory values; for practical use we suggest increasing these values by 0,5 m.
 These performances are valid for liquids with density $\rho = 1,0 \text{ Kg/dm}^3$ and kinematic viscosity $\nu = 1 \text{ mm}^2/\text{sec}$.

FCE4-FCS4 SERIES
OPERATING CHARACTERISTICS AT 50 Hz, 4 POLES

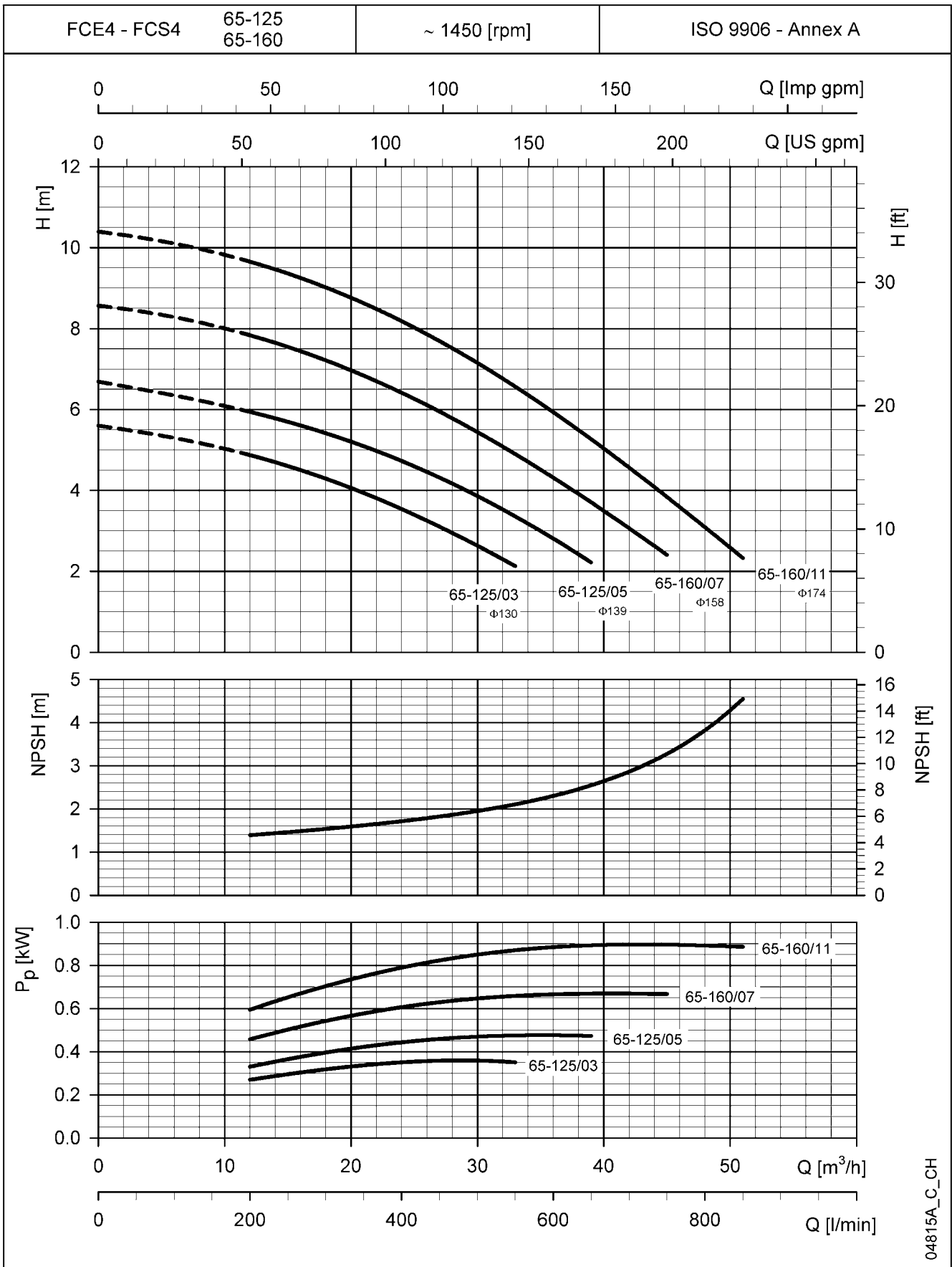

04815A_C_CH

The NPSH values are laboratory values; for practical use we suggest increasing these values by 0,5 m.
These performances are valid for liquids with density $\rho = 1,0 \text{ Kg/dm}^3$ and kinematic viscosity $\nu = 1 \text{ mm}^2/\text{sec}$.

**FCE4-FCS4 SERIES
OPERATING CHARACTERISTICS AT 50 Hz, 4 POLES**

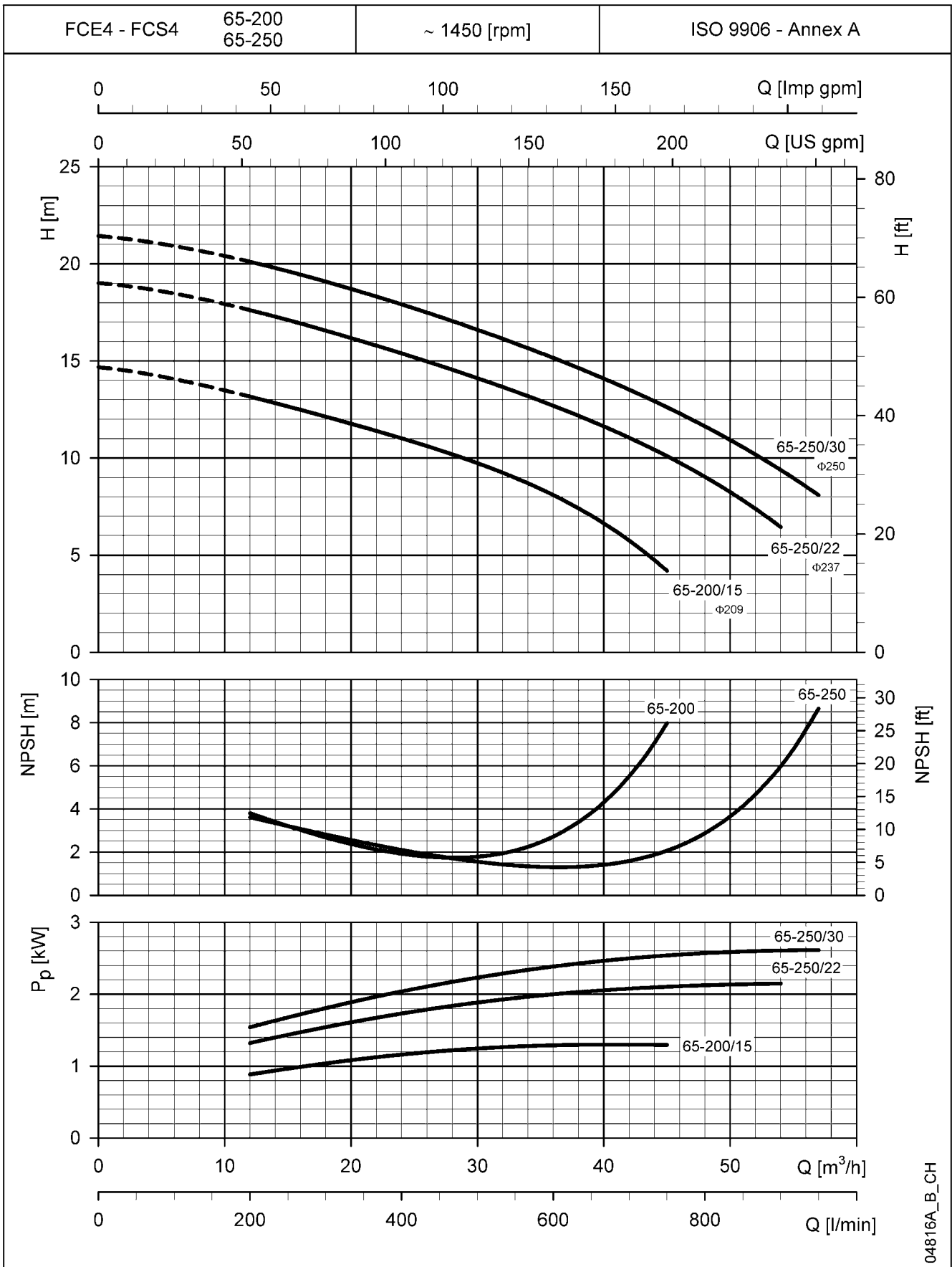

04816A_B_CH

The NPSH values are laboratory values; for practical use we suggest increasing these values by 0,5 m.
These performances are valid for liquids with density $\rho = 1,0 \text{ Kg/dm}^3$ and kinematic viscosity $\nu = 1 \text{ mm}^2/\text{sec}$.

**FCE4-FCS4 SERIES
OPERATING CHARACTERISTICS AT 50 Hz, 4 POLES**

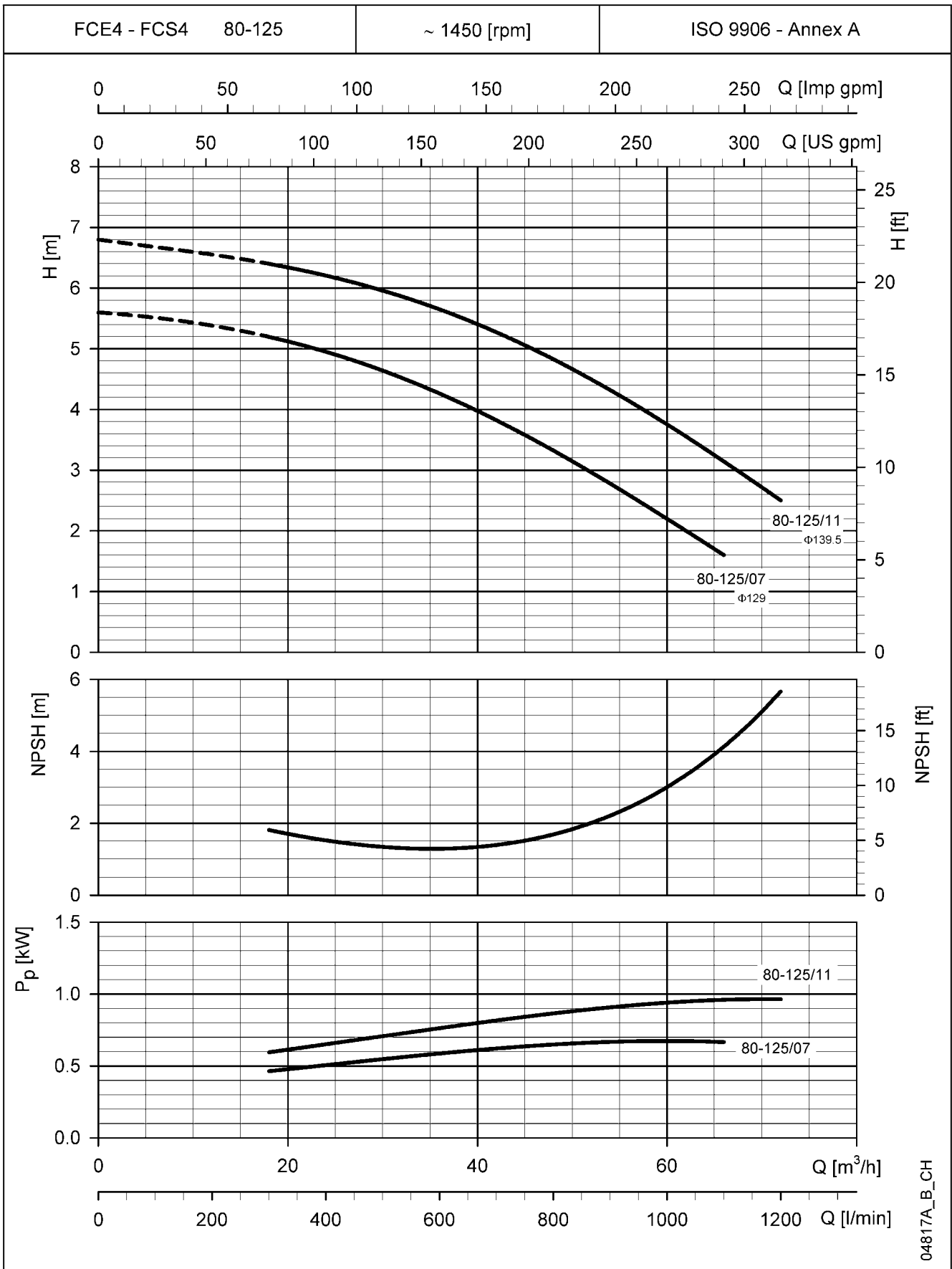

04817A_B_CH

The NPSH values are laboratory values; for practical use we suggest increasing these values by 0,5 m.
These performances are valid for liquids with density $\rho = 1,0 \text{ Kg/dm}^3$ and kinematic viscosity $\nu = 1 \text{ mm}^2/\text{sec}$.

**FCE4-FCS4 SERIES
OPERATING CHARACTERISTICS AT 50 Hz, 4 POLES**

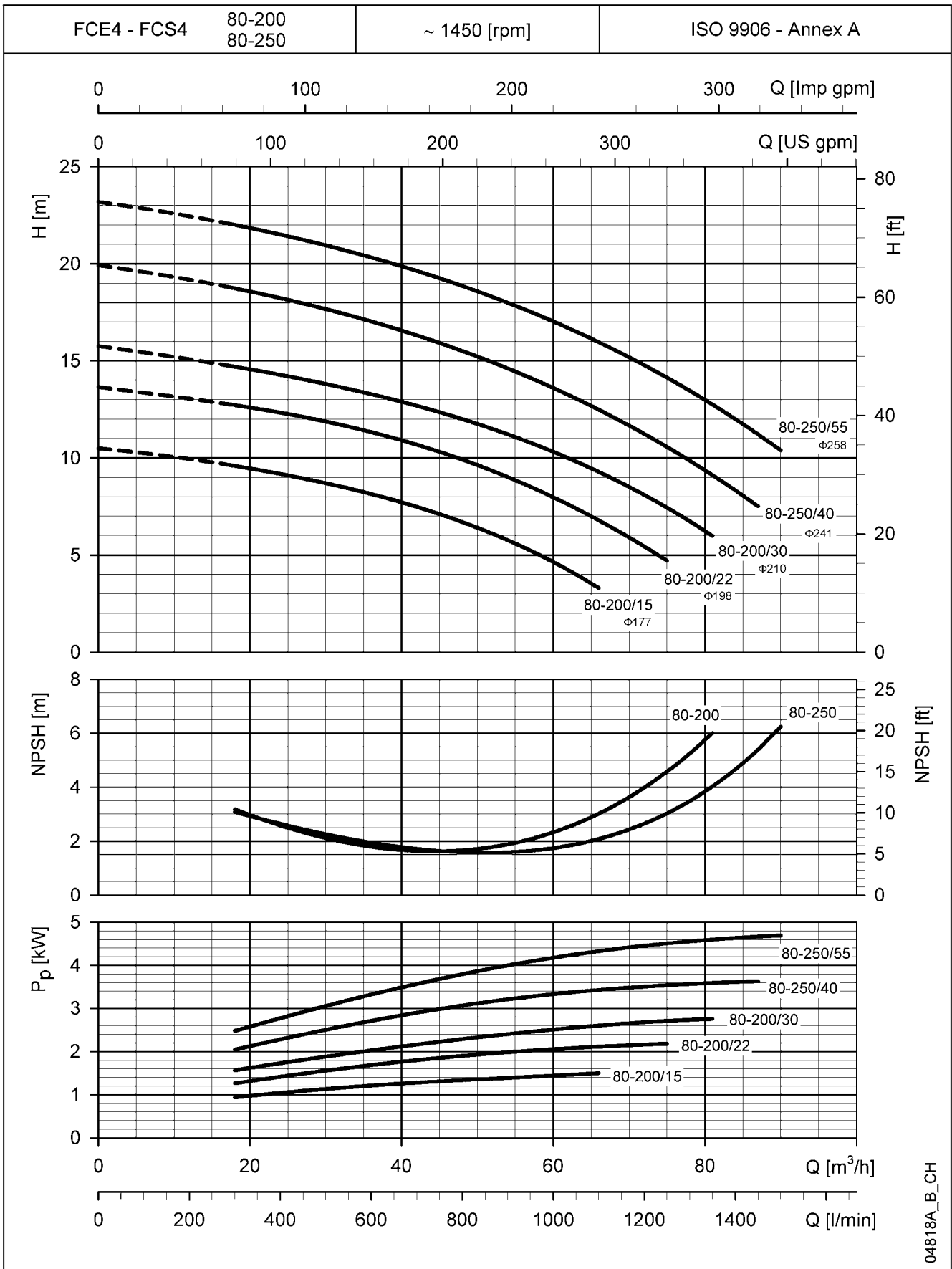

04818A_B_CH

The NPSH values are laboratory values; for practical use we suggest increasing these values by 0,5 m.
These performances are valid for liquids with density $\rho = 1,0 \text{ Kg/dm}^3$ and kinematic viscosity $\nu = 1 \text{ mm}^2/\text{sec}$.

**FCE4-FCS4 SERIES
OPERATING CHARACTERISTICS AT 50 Hz, 4 POLES**

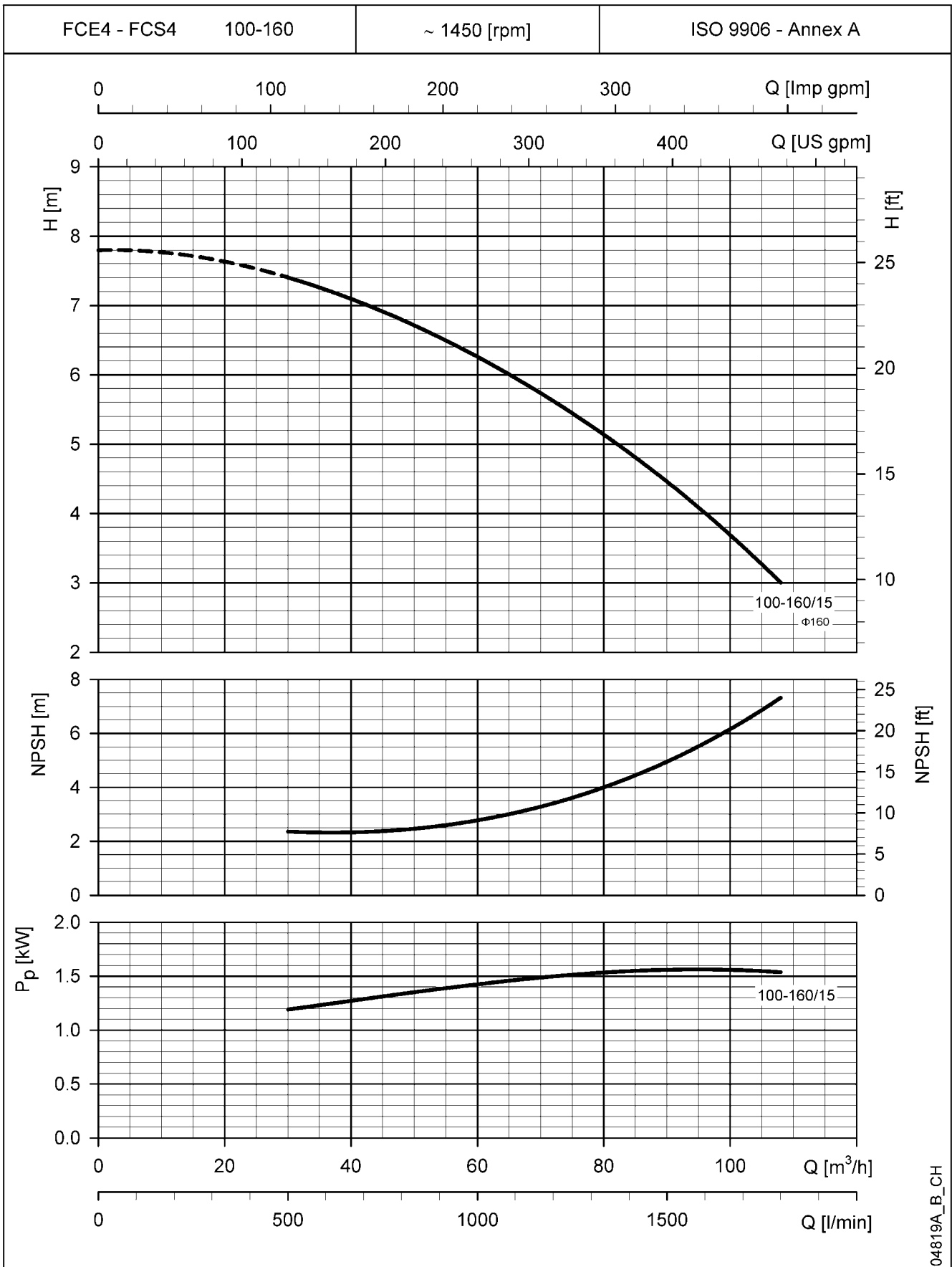

The NPSH values are laboratory values; for practical use we suggest increasing these values by 0,5 m.
These performances are valid for liquids with density $\rho = 1,0 \text{ Kg/dm}^3$ and kinematic viscosity $\nu = 1 \text{ mm}^2/\text{sec}$.

**FCE4-FCS4 SERIES
OPERATING CHARACTERISTICS AT 50 Hz, 4 POLES**

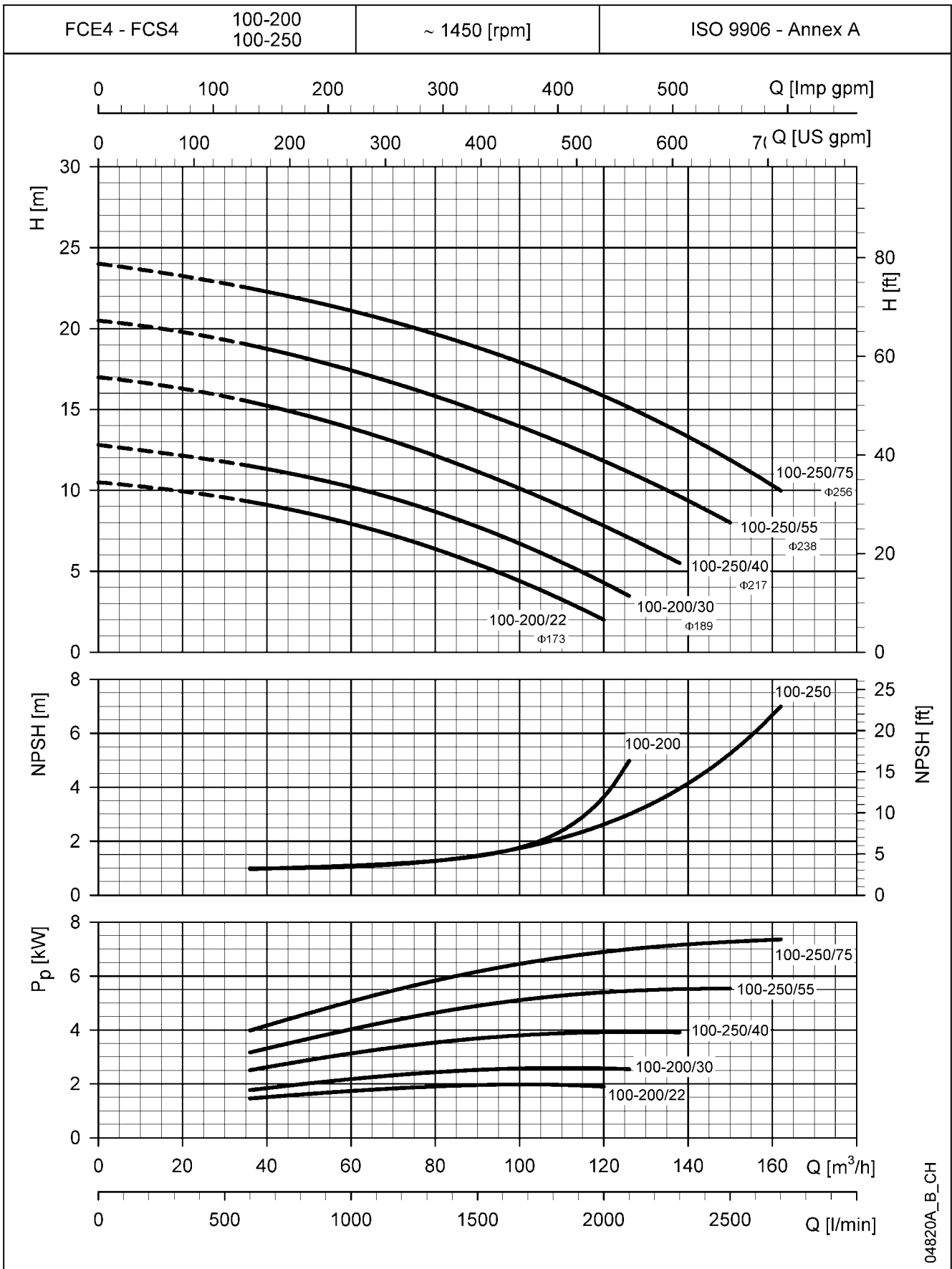

04820A_B_CH

The NPSH values are laboratory values; for practical use we suggest increasing these values by 0,5 m.
These performances are valid for liquids with density $\rho = 1,0 \text{ Kg/dm}^3$ and kinematic viscosity $\nu = 1 \text{ mm}^2/\text{sec}$.

**FCS4 SERIES
OPERATING CHARACTERISTICS AT 50 Hz, 4 POLES**

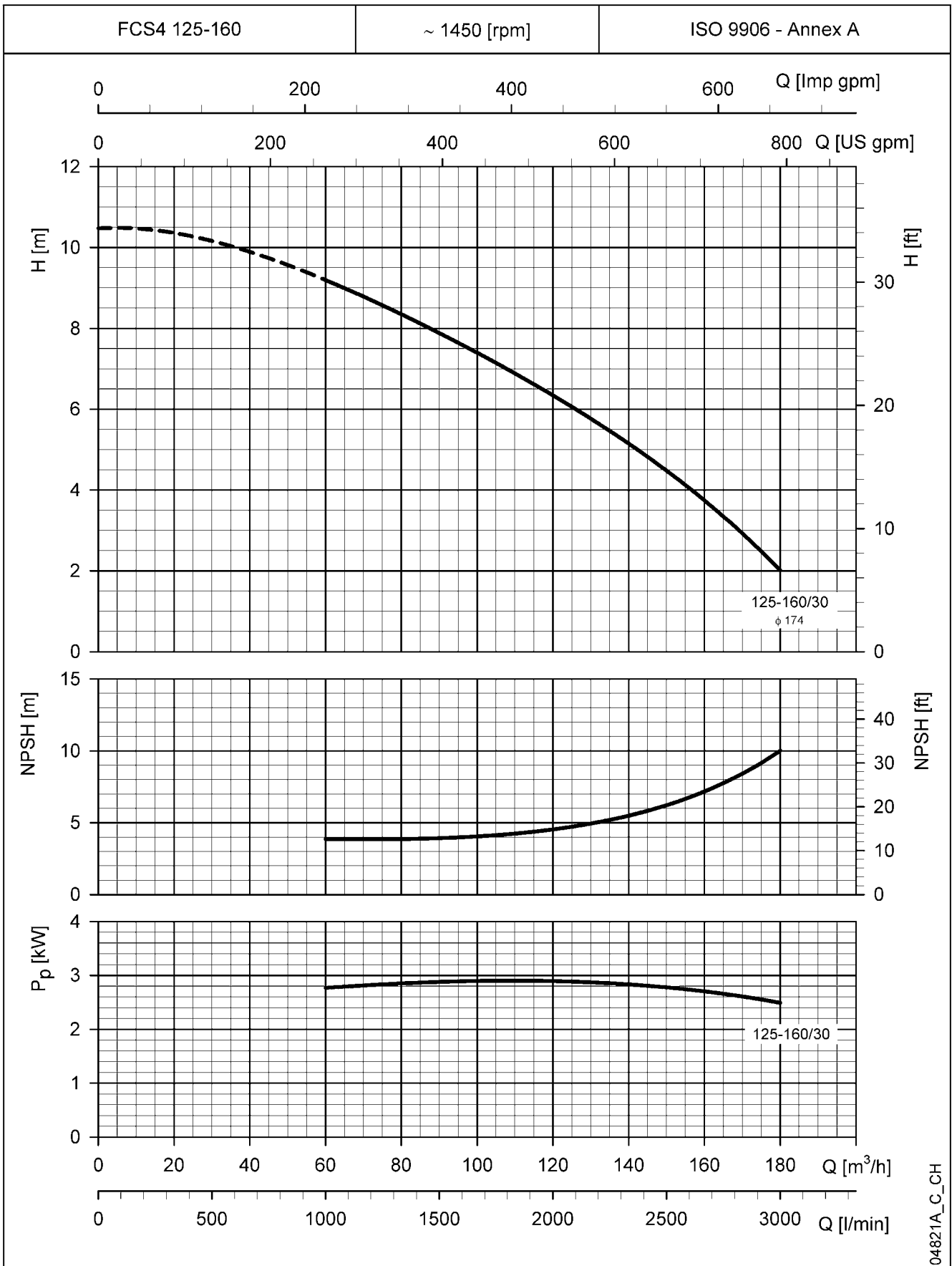

The NPSH values are laboratory values; for practical use we suggest increasing these values by 0,5 m.
These performances are valid for liquids with density $\rho = 1,0 \text{ Kg/dm}^3$ and kinematic viscosity $\nu = 1 \text{ mm}^2/\text{sec}$.

**FCS4 SERIES
OPERATING CHARACTERISTICS AT 50 Hz, 4 POLES**

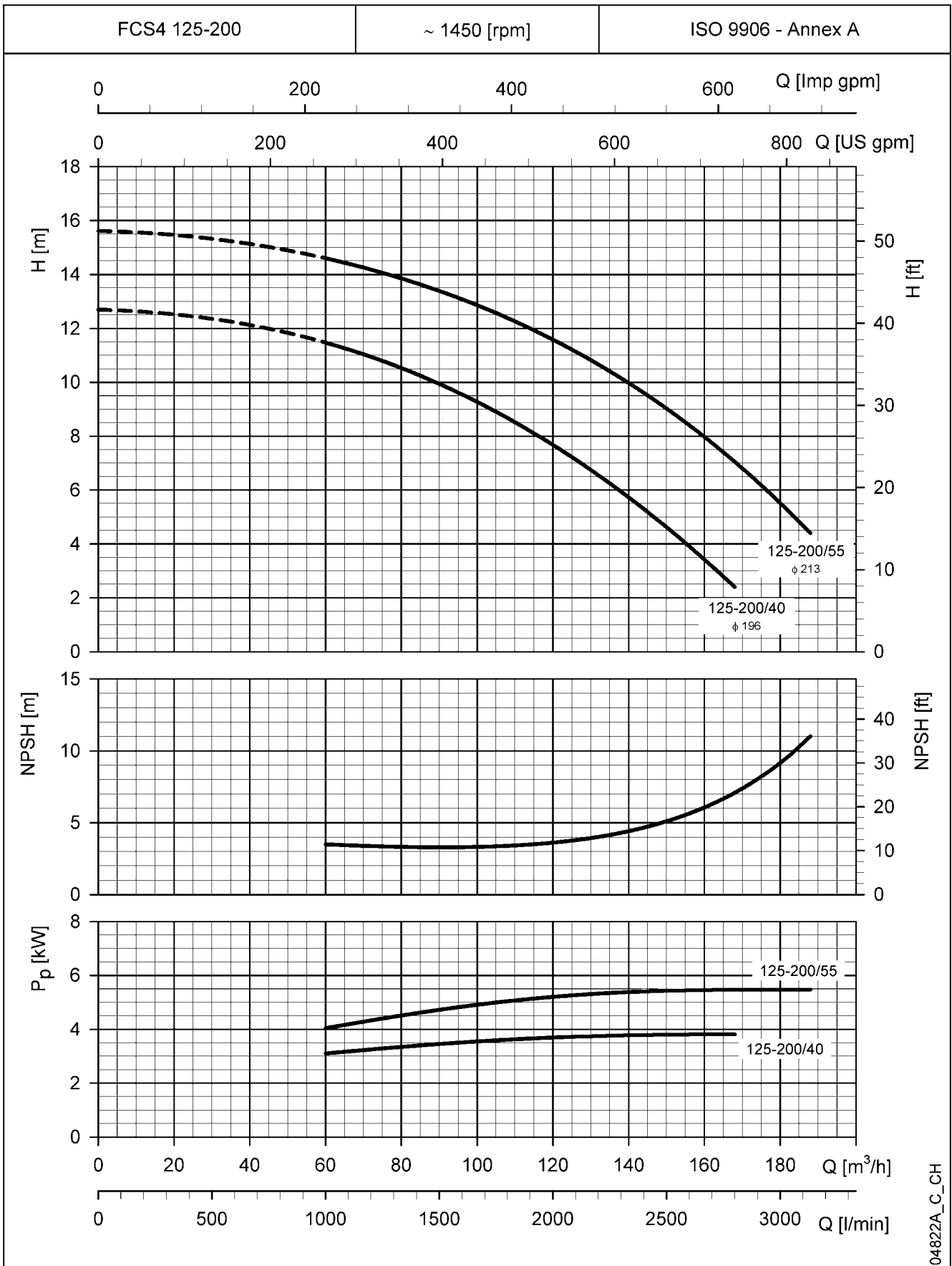

04822A_C_CH

The NPSH values are laboratory values; for practical use we suggest increasing these values by 0,5 m.
These performances are valid for liquids with density $\rho = 1,0 \text{ Kg/dm}^3$ and kinematic viscosity $\nu = 1 \text{ mm}^2/\text{sec}$.

**FCS4 SERIES
OPERATING CHARACTERISTICS AT 50 Hz, 4 POLES**

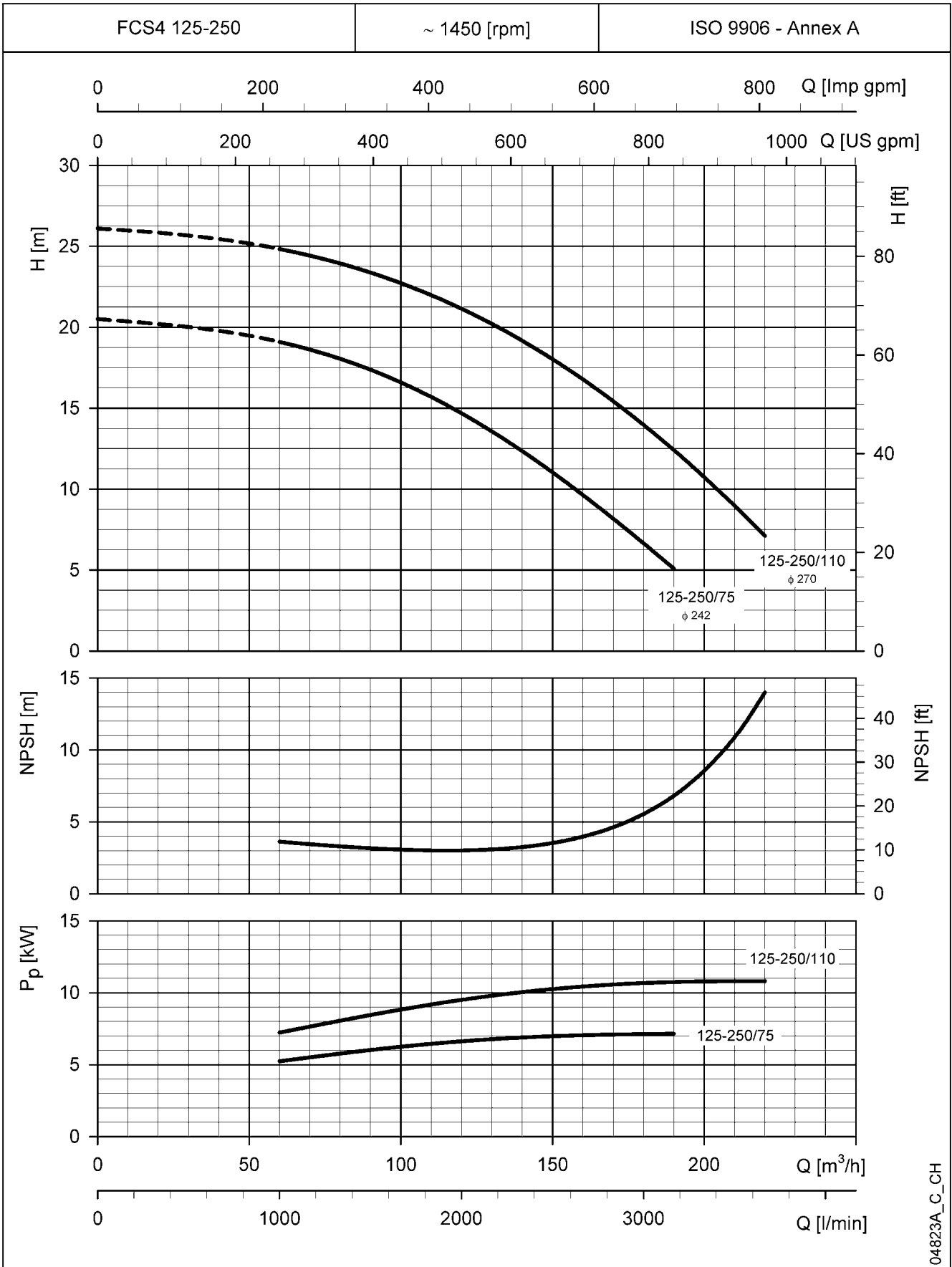

04823A_C_CH

The NPSH values are laboratory values; for practical use we suggest increasing these values by 0,5 m.
These performances are valid for liquids with density $\rho = 1,0 \text{ Kg/dm}^3$ and kinematic viscosity $\nu = 1 \text{ mm}^2/\text{sec}$.

**FCS4 SERIES
OPERATING CHARACTERISTICS AT 50 Hz, 4 POLES**

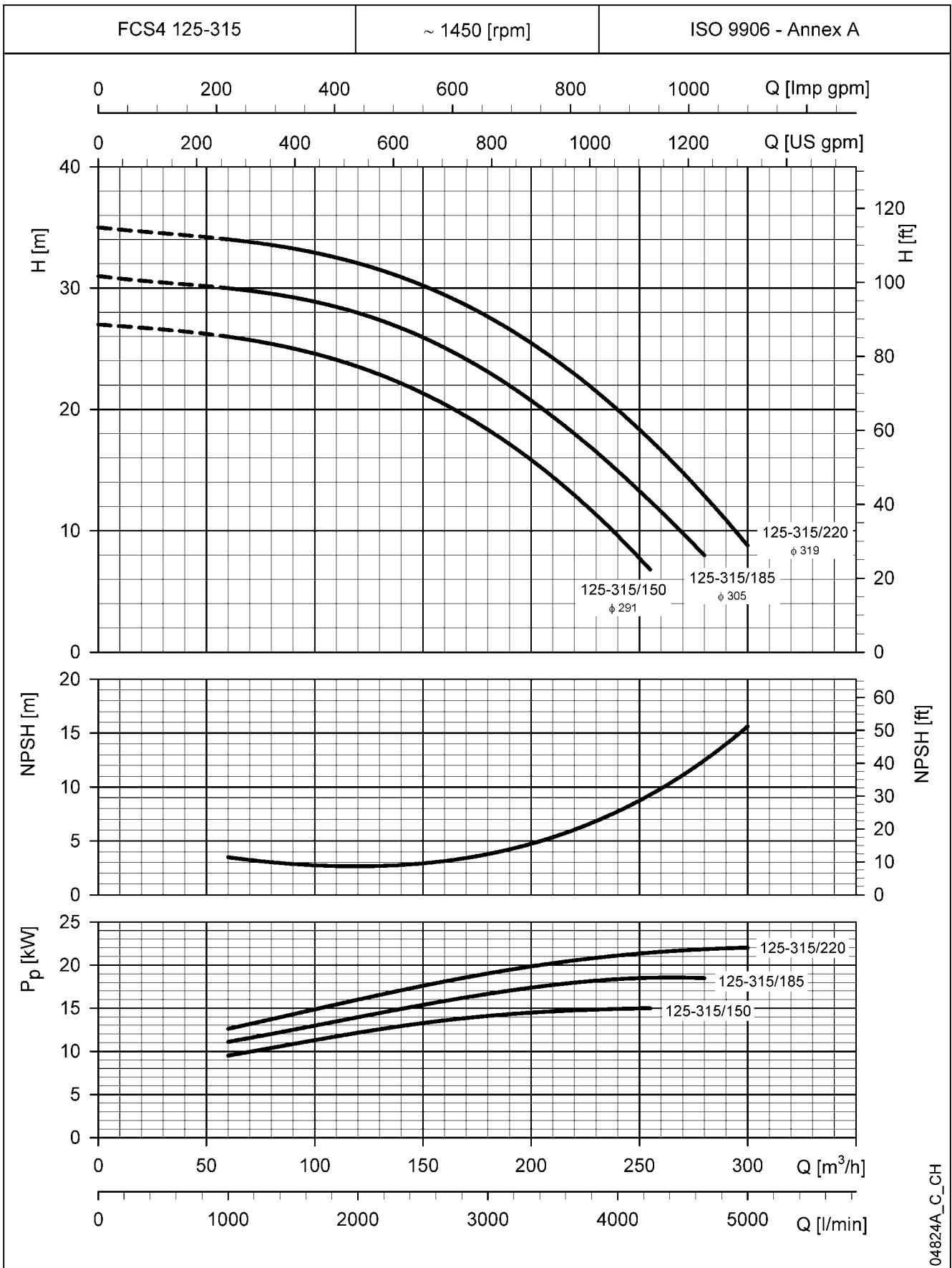

04824A_C_CH

The NPSH values are laboratory values; for practical use we suggest increasing these values by 0,5 m.
These performances are valid for liquids with density $\rho = 1,0 \text{ Kg/dm}^3$ and kinematic viscosity $\nu = 1 \text{ mm}^2/\text{sec}$.

**FCS4 SERIES
OPERATING CHARACTERISTICS AT 50 Hz, 4 POLES**

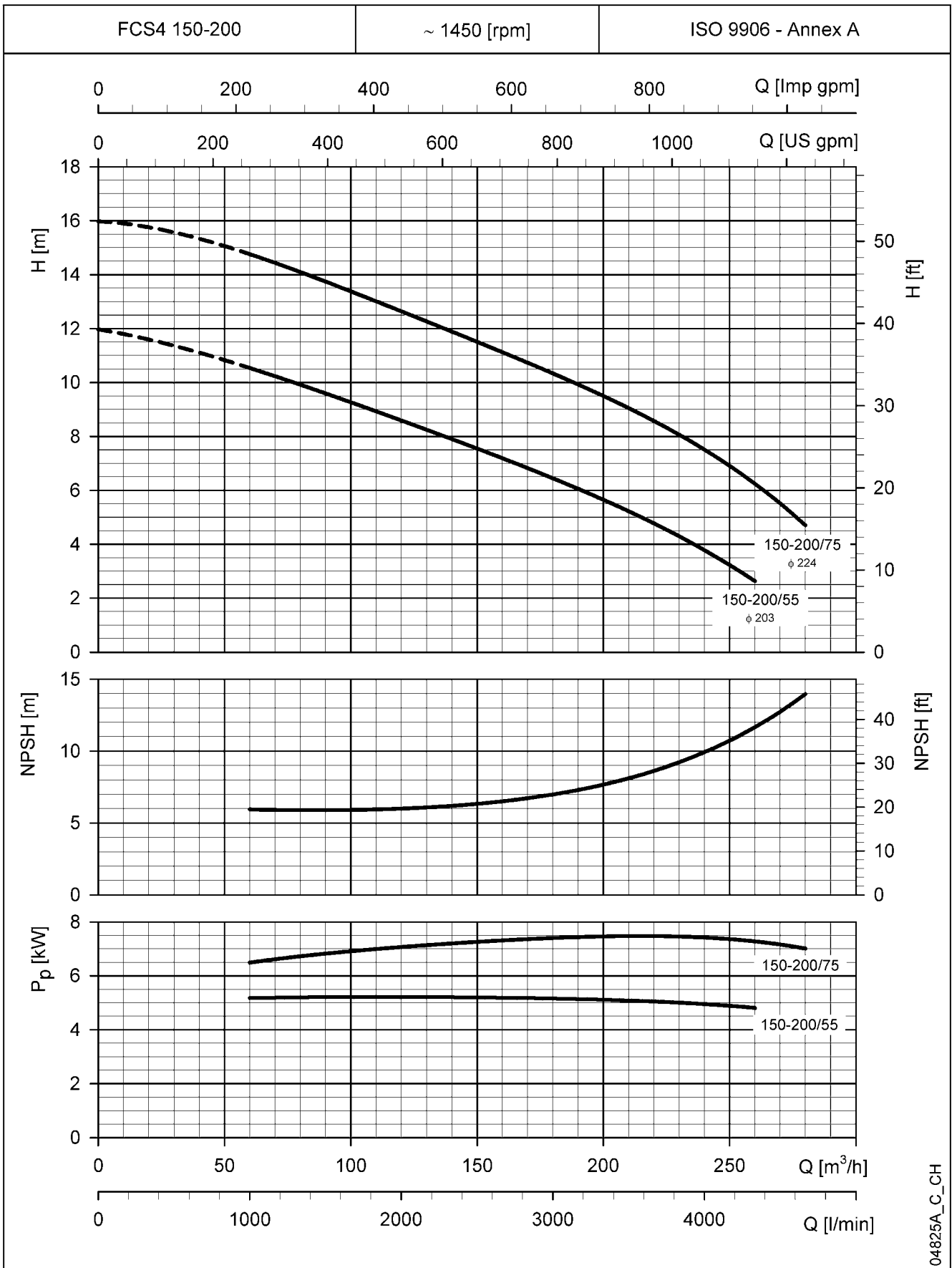

04825A_C_CH

The NPSH values are laboratory values; for practical use we suggest increasing these values by 0,5 m.
These performances are valid for liquids with density $\rho = 1,0 \text{ Kg/dm}^3$ and kinematic viscosity $\nu = 1 \text{ mm}^2/\text{sec}$.

**FCS4 SERIES
OPERATING CHARACTERISTICS AT 50 Hz, 4 POLES**

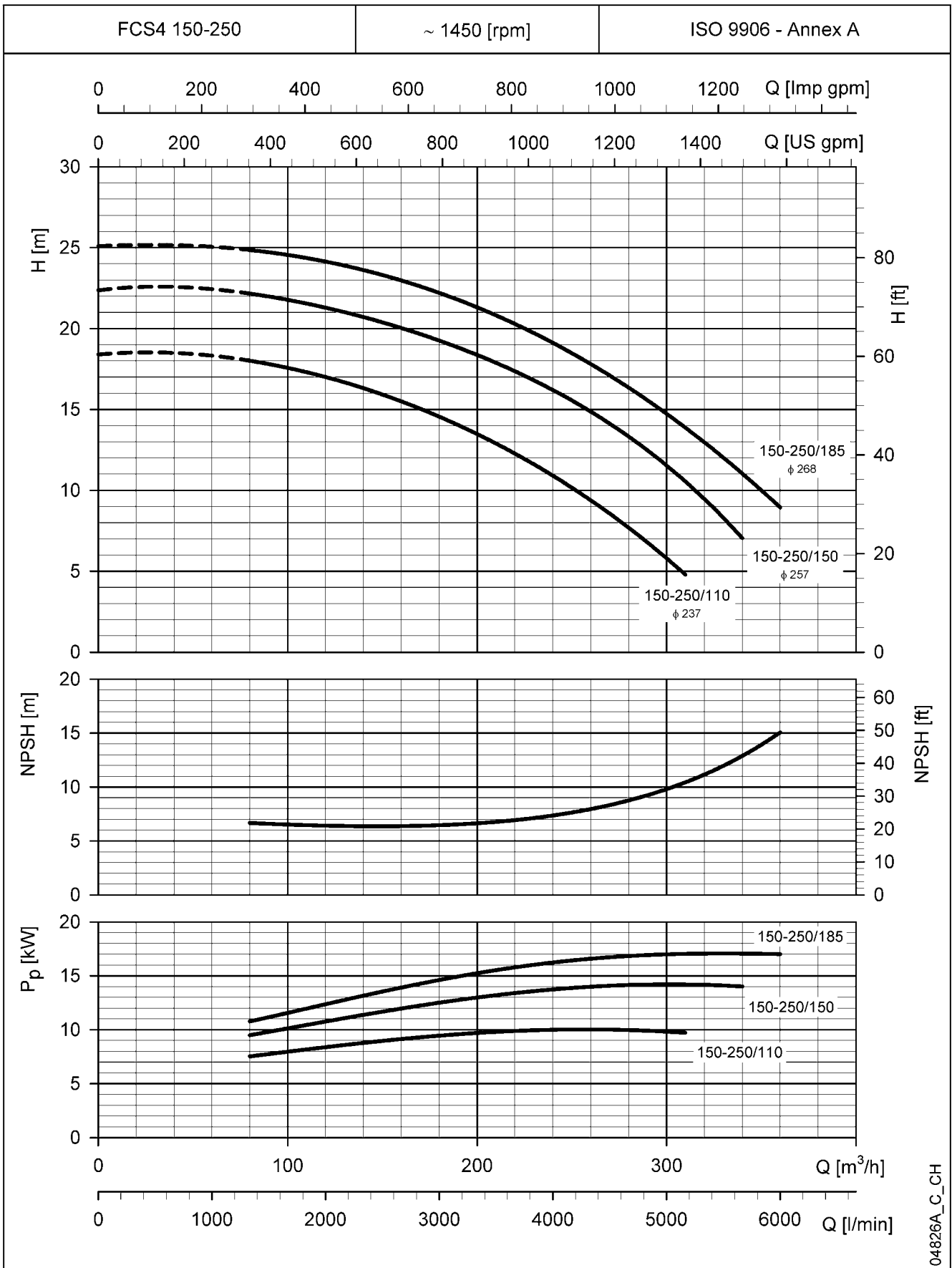

04826A_C_CH

The NPSH values are laboratory values; for practical use we suggest increasing these values by 0,5 m.
These performances are valid for liquids with density $\rho = 1,0 \text{ Kg/dm}^3$ and kinematic viscosity $\nu = 1 \text{ mm}^2/\text{sec}$.

**FCTE-FCTS SERIES (SINGLE OPERATION)
HYDRAULIC PERFORMANCE RANGE AT 50 Hz, 2 POLES**

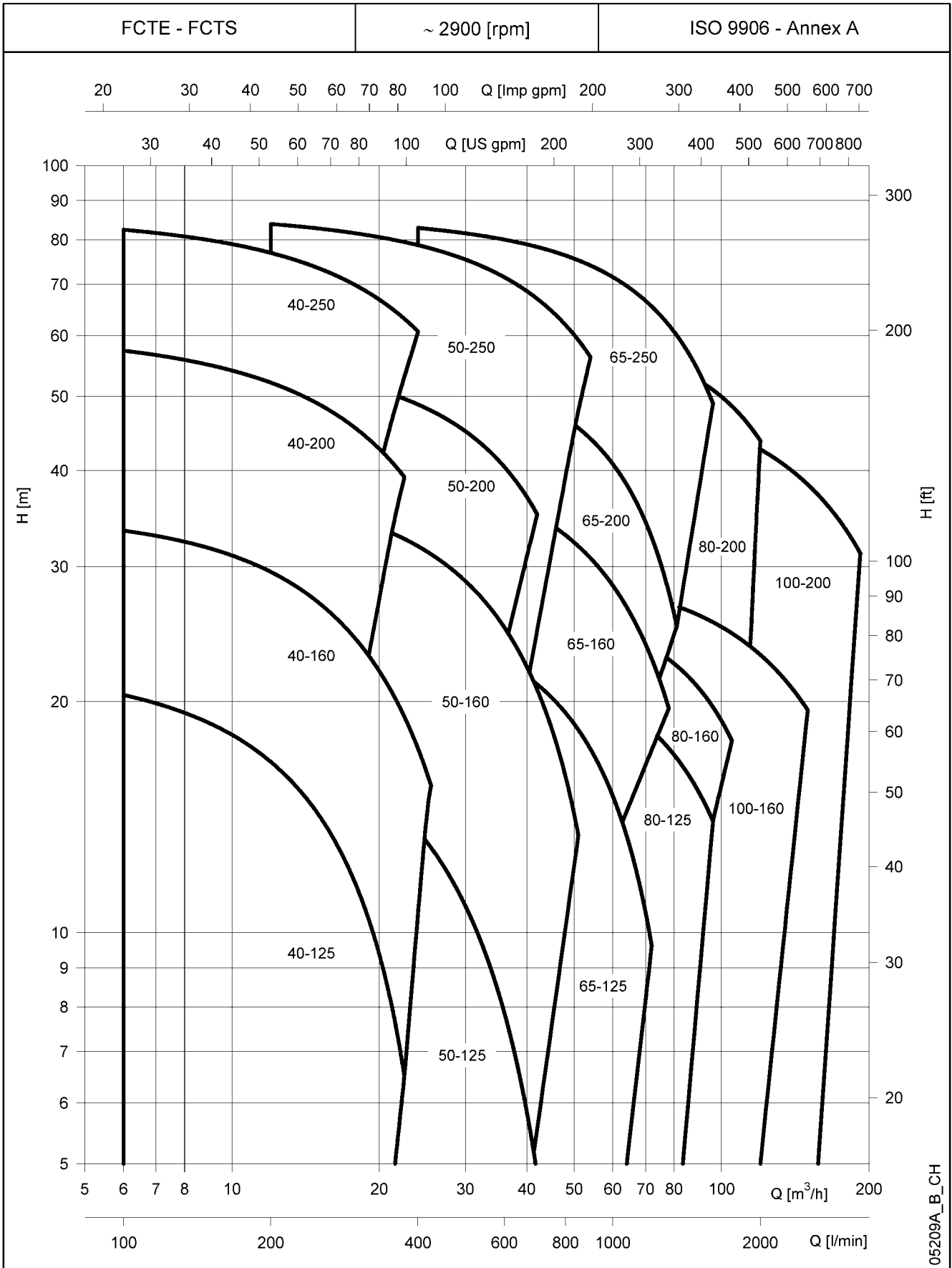

05209A_B_CH

These performances are valid for liquids with density $\rho = 1,0 \text{ Kg/dm}^3$ and kinematic viscosity $\nu = 1 \text{ mm}^2/\text{sec}$.

FCTE-FCTS SERIES (SINGLE OPERATION) HYDRAULIC PERFORMANCE TABLE AT 50 Hz, 2 POLES

PUMP TYPE	RATED POWER		Q = DELIVERY																	
			l/min	100	200	300	350	400	600	700	900	1000	1200	1300	1400	1600	1750	2000	2500	3000
	0	6	12	18	21	24	36	42	54	60	72	78	84	96	105	120	150	180		
		m ³ /h	H = TOTAL HEAD METRES COLUMN OF WATER																	
	kW	HP																		
40-125/07	0,75	1	17,9	16,0	12,5	7,4	4,3													
40-125/11	1,1	1,5	22,6	20,4	16,7	11,5	8,3													
40-160/15	1,5	2	28,2	26,0	22,3	17,2	14,1	10,6												
40-160/22	2,2	3	35,3	33,4	29,5	24,0	20,8	17,4												
40-200/ *	*	*	43,2	39,3	33,9	27,1														
40-200/40	4	5,5	52,4	48,8	43,7	37,0	33,1													
40-200/55	5,5	7,5	61,0	57,4	52,1	45,3	41,4													
40-250/75	7,5	10	75,7	71,4	66,1	59,4	55,3													
40-250/110	11	15	86,2	82,5	76,9	69,7	65,4	60,7												
50-125/11	1,1	1,5	14,4		13,2	11,6	10,5	9,4	4,2											
50-125/15	1,5	2	18,4		17,6	15,9	14,8	13,6	7,9	4,8										
50-160/22	2,2	3	26,2		24,4	22,4	21,3	19,9	13,7	10,1										
50-160/30	3	4	33,1		30,3	28,3	27,1	25,7	19,3	15,4										
50-160/40	4	5,5	39,1		36,6	34,5	33,3	31,9	25,0	20,7										
50-200/55	5,5	7,5	47,9		44,9	42,6	41,2	39,7	31,7											
50-200/75	7,5	10	57,4		54,3	51,9	50,4	48,8	40,5	35,1										
50-250/**	**	**	64,4		60,9	58,7	57,4	56,1	49,2	44,8										
50-250/110	11	15	75,0		71,3	69,0	67,7	66,2	59,2	54,9										
50-250/150	15	20	87,4		83,9	81,6	80,2	78,7	71,5	67,1	56,3									
65-125/22	2,2	3	17,8					16,3	13,9	12,3	8,3	5,9								
65-125/30	3	4	21,8					20,3	17,9	16,3	12,3	10,0								
65-125/40	4	5,5	25,7					24,6	22,5	21,1	17,3	15,1	9,6							
65-160/55	5,5	7,5	34,1					32,8	30,6	29,1	25,2	22,9	17,4							
65-160/75	7,5	10	41,6					39,3	36,7	34,9	30,8	28,3	22,7	19,6						
65-200/**	**	**	52,0					48,7	45,8	43,9	38,9	35,8	28,1	23,4						
65-200/110	11	15	58,8					54,3	51,1	49,1	44,0	40,8	32,7	27,8						
65-250/150	15	20	69,8					65,5	62,7	61,1	56,9	54,4	48,1	44,4	40,1					
65-250/185	18,5	25	78,6					73,7	70,8	69,1	65,0	62,5	56,5	52,9	48,8					
65-250/220	22	30	86,8					82,9	80,1	78,3	74,1	71,5	65,5	62,0	58,1	49,0				
80-125/30	3	4	15,8					14,4	13,8	12,2	11,3	9,3	8,2	7,1						
80-125/40	4	5,5	19,0					17,8	17,3	15,9	15,1	13,3	12,3	11,2						
80-125/55	5,5	7,5	23,6					22,3	21,8	20,7	20,0	18,3	17,4	16,4	14,0					
80-160/75	7,5	10	28,2					26,7	26,3	25,4	24,9	23,5	22,7	21,8	19,7	17,8				
80-200/110	11	15	40,7					38,1	37,5	35,9	35,0	32,9	31,7	30,4	27,5	25,0				
80-200/150	15	20	51,1					48,0	47,3	45,7	44,7	42,6	41,5	40,2	37,3	34,8				
80-200/185	18,5	25	57,2					54,0	53,3	51,8	50,9	49,0	47,8	46,6	43,8	41,4				
80-200/220	22	30	63,9					60,9	60,3	58,8	58,0	56,1	55,0	53,8	51,0	48,6	43,8			
100-160/110	11	15	29,0									27,6	26,8	26,3	25,7	24,5	23,4	21,4	16,5	
100-200/185	18,5	25	39,8										37,9	37,5	37,0	36,0	35,2	33,5	29,5	24,5
100-200/220	22	30	47,5										45,3	44,9	44,4	43,4	42,5	40,8	36,7	31,6

* FCTE 40-200/40A : 4 [kW] - 5.5 [HP] , FCTS 40-200/30 : 3 [kW] - 4 [HP]

fcte-fcts-2p50S-en_c_th

** FCTE 50-250/92 : 9.2 [kW] - 12.5 [HP] , FCTS 50-250/110A : 11 [kW] - 15 [HP]

FCTE 65-200/92 : 9.2 [kW] - 12.5 [HP] , FCTS 65-200/110A : 11 [kW] - 15 [HP]

Performances according to ISO 9906 - Annex A.

**FCTE-FCTS SERIES (PARALLEL OPERATION)
HYDRAULIC PERFORMANCE RANGE AT 50 Hz, 2 POLES**

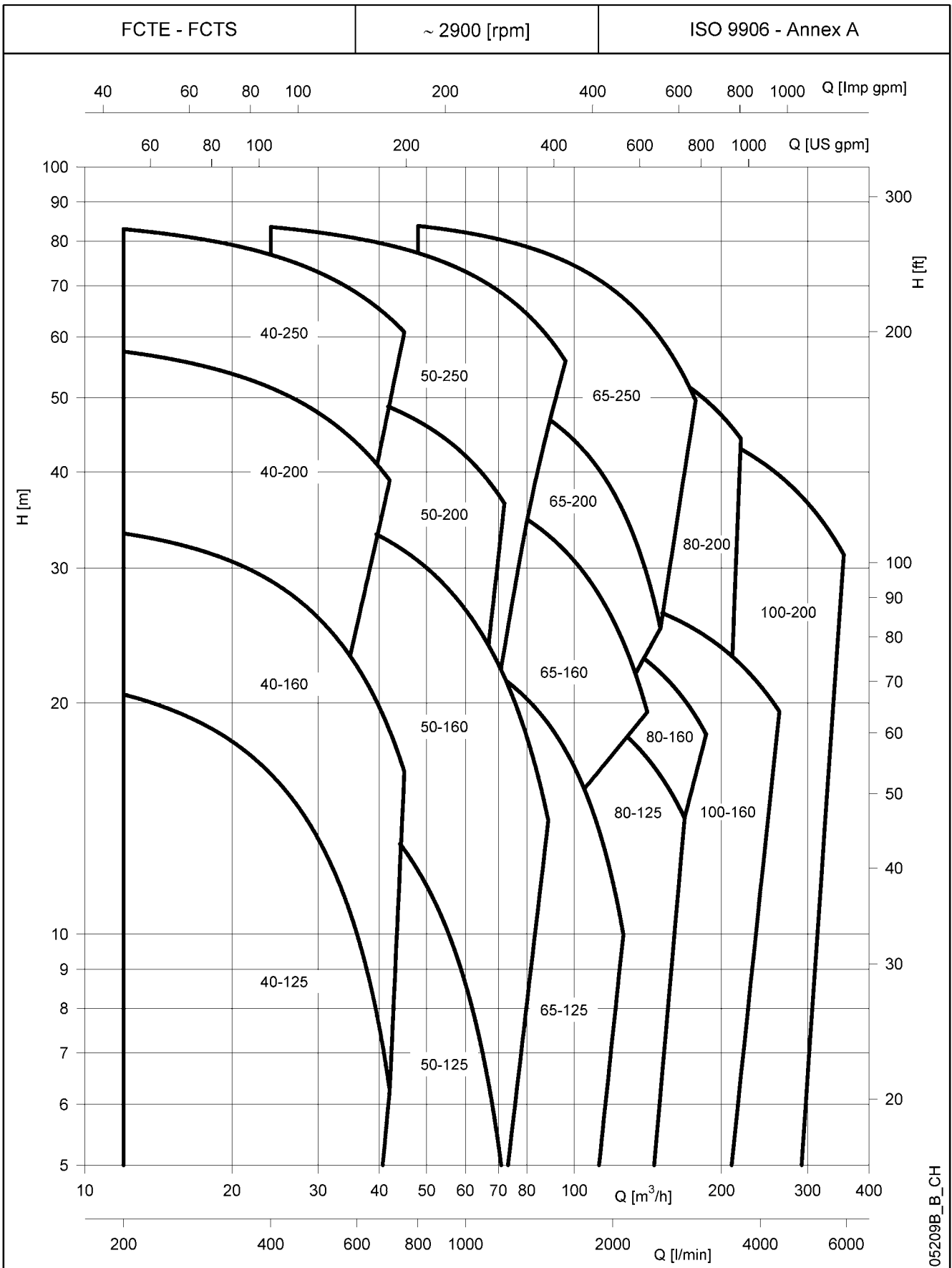

05209B_B_CH

These performances are valid for liquids with density $\rho = 1,0 \text{ Kg/dm}^3$ and kinematic viscosity $\nu = 1 \text{ mm}^2/\text{sec}$.

FCTE-FCTS SERIES (PARALLEL OPERATION) HYDRAULIC PERFORMANCE TABLE AT 50 Hz, 2 POLES

PUMP TYPE	RATED POWER		Q = DELIVERY																		
	2 x kW	2 x HP	l/min 0	200	400	600	700	800	1000	1200	1600	1800	2000	2200	2400	2800	3200	3500	4250	5550	
			m ³ /h 0	12	24	36	42	48	60	72	96	108	120	132	144	168	192	210	255	333	
H = TOTAL HEAD METRES COLUMN OF WATER																					
40-125/07	0,75	1	17,9	15,9	11,7	5,6															
40-125/11	1,1	1,5	23,0	20,5	16,2	10,0	6,3														
40-160/15	1,5	2	28,4	26,0	21,6	15,4	11,7														
40-160/22	2,2	3	35,3	33,3	28,9	22,3	18,4														
40-200/ *	*	*	43,4	39,2	33,3	25,6															
40-200/40	4	5,5	52,5	48,5	42,8	35,3															
40-200/55	5,5	7,5	61,2	57,5	51,5	43,6	39,0														
40-250/75	7,5	10	75,1	69,5	62,8	54,6	49,9														
40-250/110	11	15	86,8	83,0	76,8	68,5	63,6														
50-125/11	1,1	1,5	14,2		12,7	10,6	9,3	7,8	4,4												
50-125/15	1,5	2	18,4		17,1	15,0	13,6	12,1	8,6	4,6											
50-160/22	2,2	3	26,4		24,0	21,6	20,1	18,5	14,8	10,4											
50-160/30	3	4	33,3		30,1	27,5	26,0	24,3	20,4	15,8											
50-160/40	4	5,5	39,5		36,8	34,1	32,5	30,7	26,5	21,6											
50-200/55	5,5	7,5	47,6		44,2	41,4	39,6	37,7	33,2												
50-200/75	7,5	10	56,9		53,3	50,4	48,6	46,6	42,0	36,4											
50-250/**	**	**	64,6		61,0	58,3	56,7	54,8	50,6	45,6											
50-250/110	11	15	75,1		71,2	68,4	66,7	64,9	60,8	55,9											
50-250/150	15	20	87,3		83,5	80,7	79,0	77,2	73,0	68,1	55,9										
65-125/22	2,2	3	18,1					15,8	14,5	12,8	8,3	5,4									
65-125/30	3	4	22,1					19,8	18,4	16,8	12,4	9,6									
65-125/40	4	5,5	25,7					24,2	23,0	21,5	17,4	14,7	11,7								
65-160/55	5,5	7,5	34,0					32,4	31,1	29,4	25,1	22,4	19,4								
65-160/75	7,5	10	41,8					39,4	37,9	36,1	31,6	28,8	25,7	22,3							
65-200/**	**	**	52,0					48,5	46,9	44,9	39,7	36,3	32,5	28,0							
65-200/110	11	15	58,7					54,2	52,5	50,4	45,1	41,7	37,7	33,2	27,9						
65-250/150	15	20	69,6					65,7	64,2	62,4	57,8	54,9	51,7	48,0	43,8						
65-250/185	18,5	25	78,3					74,1	72,5	70,7	66,0	63,2	60,0	56,4	52,4	43,0					
65-250/220	22	30	87,3					83,8	82,1	80,2	75,3	72,4	69,2	65,7	61,8	53,2					
80-125/30	3	4	15,7							14,1	12,4	11,3	10,2	9,0	7,8						
80-125/40	4	5,5	18,9							17,7	16,2	15,2	14,2	13,1	11,9						
80-125/55	5,5	7,5	23,6							21,7	20,4	19,6	18,8	17,8	16,7	14,2					
80-160/75	7,5	10	28,4							26,8	25,7	25,0	24,3	23,4	22,4	20,2					
80-200/110	11	15	40,9							38,2	36,5	35,5	34,3	33,1	31,8	28,7	25,1	22,1			
80-200/150	15	20	50,4							47,4	45,7	44,7	43,6	42,4	41,1	38,0	34,5	31,5			
80-200/185	18,5	25	57,8							54,5	52,8	51,8	50,7	49,5	48,2	45,3	41,9	39,0			
80-200/220	22	30	63,6							61,3	59,7	58,7	57,6	56,4	55,1	52,1	48,7	45,8			
100-160/110	11	15	28,8									27,7	27,3	26,8	26,3	25,0	23,5	22,3	18,5		
100-200/185	18,5	25	39,7											37,8	37,4	36,4	35,2	34,1	31,0	23,4	
100-200/220	22	30	47,5												45,3	44,9	43,9	42,8	41,8	38,7	30,9

* FCTE 40-200/40A : 4 [kW] - 5.5 [HP] , FCTS 40-200/30 : 3 [kW] - 4 [HP]

fcte-fcts-2p50P-en_c_th

** FCTE 50-250/92 : 9.2 [kW] - 12.5 [HP] , FCTS 50-250/110A : 11 [kW] - 15 [HP]

FCTE 65-200/92 : 9.2 [kW] - 12.5 [HP] , FCTS 65-200/110A : 11 [kW] - 15 [HP]

Performances according to ISO 9906 - Annex A.

FCTE4-FCTS4 SERIES (SINGLE OPERATION)
HYDRAULIC PERFORMANCE RANGE AT 50 Hz, 4 POLES

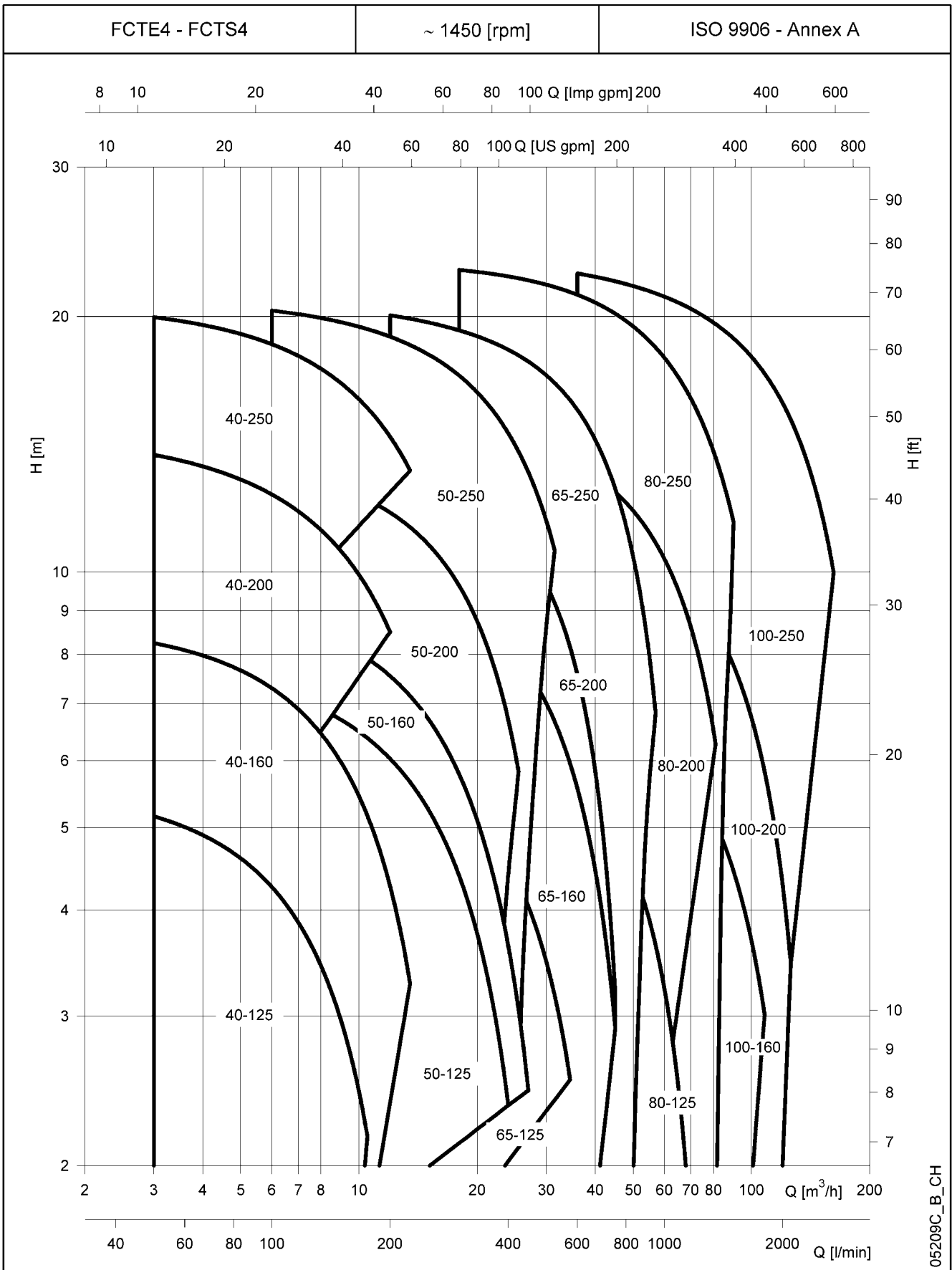

05209C_B_CH

These performances are valid for liquids with density $\rho = 1,0 \text{ Kg/dm}^3$ and kinematic viscosity $\nu = 1 \text{ mm}^2/\text{sec}$.

FCTE4-FCTS4 SERIES (SINGLE OPERATION) HYDRAULIC PERFORMANCE TABLE AT 50 Hz, 4 POLES

PUMP TYPE	RATED POWER		Q = DELIVERY																	
			l/min	50	100	150	175	200	300	400	500	600	700	900	1200	1400	1600	1750	2000	2500
	0	3	6	9	10,5	12	18	24	30	36	42	54	72	84	96	105	120	150		
	kW	HP	H = TOTAL HEAD METRES COLUMN OF WATER																	
40-125/02A *	0,25	0,33	4,6	4,2	3,3	2,1														
40-125/02 *	0,25	0,33	5,7	5,2	4,3	3,0	2,2													
40-160/02 *	0,25	0,33	7,0	6,4	5,5	4,2	3,4	2,6												
40-160/03 *	0,37	0,5	8,8	8,3	7,3	6,0	5,2	4,3												
40-200/05	0,55	0,75	12,8	11,8	10,5	8,7	7,7													
40-200/07	0,75	1	14,5	13,6	12,2	10,3	9,3	8,1												
40-250/11	1,1	1,5	18,5	17,6	16,2	14,4	13,3	12,2												
40-250/15	1,5	2	20,9	20,0	18,6	16,7	15,6	14,4												
50-125/02 *	0,25	0,33	6,3		5,7	5,2	4,9	4,6	3,0											
50-125/03 *	0,37	0,5	7,9		7,3	6,8	6,4	6,0	4,3	2,4										
50-160/05 *	0,55	0,75	9,4		8,8	8,2	7,9	7,5	5,8	3,6										
50-200/07	0,75	1	11,7		10,7	10,0	9,6	9,2	7,1	4,2										
50-200/11	1,1	1,5	14,1		13,2	12,5	12,2	11,8	9,6	6,7										
50-250/15	1,5	2	18,1		17,0	16,3	16,0	15,6	13,7	11,3	8,1									
50-250/22	2,2	3	21,3		20,3	19,7	19,3	18,9	17,0	14,6	11,5									
65-125/03 *	0,37	0,5	5,6					4,9	4,3	3,4	2,3									
65-125/05 *	0,55	0,75	6,4					6,0	5,4	4,5	3,5									
65-160/07	0,75	1	8,4					8,0	7,3	6,3	5,2	3,8	2,3							
65-160/11	1,1	1,5	10,3					9,7	9,1	8,2	7,0	5,6	3,9							
65-200/15	1,5	2	14,3					13,2	12,3	11,2	9,7	7,6	4,8							
65-250/22	2,2	3	19,0					17,6	16,7	15,7	14,4	12,8	10,7	4,9						
65-250/30	3	4	21,4					20,1	19,3	18,3	17,1	15,5	13,6	8,5						
80-125/07	0,75	1	5,6						5,3	5,0	4,7	4,2	3,7	2,4						
80-125/11	1,1	1,5	7,0						6,6	6,3	6,0	5,7	5,2	4,0						
80-200/15	1,5	2	11,7						10,2	9,7	9,1	8,5	7,8	6,1						
80-200/22	2,2	3	14,7						13,3	12,8	12,2	11,5	10,8	9,2	6,3					
80-200/30	3	4	16,7						15,1	14,6	14,0	13,4	12,8	11,3	8,2					
80-250/40	4	5,5	19,6						19,1	18,6	18,1	17,4	16,7	14,8	11,2	8,2				
80-250/55	5,5	7,5	23,3						22,7	22,3	21,8	21,2	20,5	18,9	15,6	12,9				
100-160/15	1,5	2	7,9								7,6	7,4	7,1	6,4	5,0	4,0	2,9	2,1		
100-200/22	2,2	3	9,7									9,1	8,9	8,2	7,0	6,0	4,9	4,0	2,3	
100-200/30	3	4	11,6										10,9	10,7	10,0	8,8	7,8	6,6	5,6	3,8
100-250/40	4	5,5	15,2											14,4	14,2	13,6	12,3	11,3	10,1	7,2
100-250/55	5,5	7,5	18,7												17,8	17,6	17,0	15,7	14,8	13,6
100-250/75	7,5	10	21,6													21,2	20,9	20,4	19,2	18,2

* FCTE4 VERSION ONLY

fcte4-fcts4-4p50S-en_e_th

Performances according to ISO 9906 - Annex A.

**FCTE4-FCTS4 SERIES (PARALLEL OPERATION)
HYDRAULIC PERFORMANCE RANGE AT 50 Hz, 4 POLES**



05209D_B_CH

These performances are valid for liquids with density $\rho = 1,0 \text{ Kg/dm}^3$ and kinematic viscosity $\nu = 1 \text{ mm}^2/\text{sec}$.

FCTE4-FCTS4 SERIES (PARALLEL OPERATION) HYDRAULIC PERFORMANCE TABLE AT 50 Hz, 4 POLES

PUMP TYPE	RATED POWER		Q = DELIVERY																		
	2 x kW	2 x HP	l/min 0	100	200	300	350	400	600	700	900	1000	1100	1600	1800	2400	3000	3500	4000	4600	
			m ³ /h 0	6	12	18	21	24	36	42	54	60	66	96	108	144	180	210	240	276	
H = TOTAL HEAD METRES COLUMN OF WATER																					
40-125/02A *	0,25	0,33	4,6	4,1	3,2	1,7															
40-125/02 *	0,25	0,33	5,8	5,2	4,2	2,6															
40-160/02 *	0,25	0,33	7,0	6,4	5,4	3,8	2,9														
40-160/03 *	0,37	0,5	8,8	8,3	7,2	5,6	4,6	3,5													
40-200/05	0,55	0,75	12,9	11,8	10,3	8,4															
40-200/07	0,75	1	14,8	13,6	12,1	10,2	9,0														
40-250/11	1,1	1,5	18,5	17,6	16,1	14,0	12,8														
40-250/15	1,5	2	21,1	20,0	18,5	16,4	15,2	13,9													
50-125/02 *	0,25	0,33	6,3		5,6	5,0	4,6	4,2	2,2												
50-125/03 *	0,37	0,5	8,1		7,2	6,5	6,1	5,7	3,6	2,3											
50-160/05 *	0,55	0,75	9,6		8,8	8,1	7,7	7,2	5,0	3,6											
50-200/07	0,75	1	11,5		10,6	9,8	9,3	8,8	6,3	4,7											
50-200/11	1,1	1,5	14,0		13,0	12,3	11,8	11,3	8,7	7,1											
50-250/15	1,5	2	18,1		17,0	16,2	15,7	15,3	12,9	11,5	7,9										
50-250/22	2,2	3	21,3		20,2	19,4	19,0	18,5	16,0	14,6	11,0										
65-125/03 *	0,37	0,5	5,5					4,7	4,0	3,5	2,2										
65-125/05 *	0,55	0,75	6,3					5,9	5,2	4,7	3,4	2,7									
65-160/07	0,75	1	8,5					7,8	7,0	6,5	5,3	4,5	3,7								
65-160/11	1,1	1,5	10,2					9,7	8,9	8,3	7,0	6,2	5,4								
65-200/15	1,5	2	14,4					13,1	12,1	11,4	9,8	8,8	7,6								
65-250/22	2,2	3	19,3					17,7	16,6	16,1	14,6	13,8	12,8	5,9							
65-250/30	3	4	21,6					20,2	19,3	18,7	17,3	16,5	15,5	9,2							
80-125/07	0,75	1	5,7						5,2	5,0	4,6	4,4	4,1	2,4							
80-125/11	1,1	1,5	7,0						6,6	6,4	6,1	5,9	5,6	4,1	3,3						
80-200/15	1,5	2	11,5						10,1	9,8	9,2	8,9	8,6	6,5	5,5						
80-200/22	2,2	3	14,8						13,2	12,9	12,3	12,0	11,7	9,7	8,7						
80-200/30	3	4	16,7						15,7	15,4	14,9	14,6	14,2	12,0	10,9	6,8					
80-250/40	4	5,5	19,8						19,1	18,8	18,3	17,9	17,6	15,3	14,1	9,9					
80-250/55	5,5	7,5	23,2						22,6	22,4	21,9	21,6	21,3	19,2	18,2	14,3					
100-160/15	1,5	2	7,8								7,5	7,4	7,3	6,5	6,1	4,5	2,5				
100-200/22	2,2	3	9,7										9,1	8,3	7,9	6,4	4,5	2,6			
100-200/30	3	4	11,6										11,0	10,2	9,8	8,3	6,4	4,5	2,1		
100-250/40	4	5,5	15,1										14,4	13,7	13,3	11,8	9,9	7,9	5,5		
100-250/55	5,5	7,5	18,7										17,8	17,1	16,7	15,5	13,7	11,8	9,5	6,0	
100-250/75	7,5	10	21,6										21,1	20,4	20,1	18,8	17,1	15,3	13,1	9,9	

* FCTE4 VERSION ONLY

fcte4-fcts4-4p50P-en_e_th

Performances according to ISO 9906 - Annex A.

**FCTS4 SERIES (SINGLE OPERATION)
HYDRAULIC PERFORMANCE RANGE AT 50 Hz, 4 POLES**

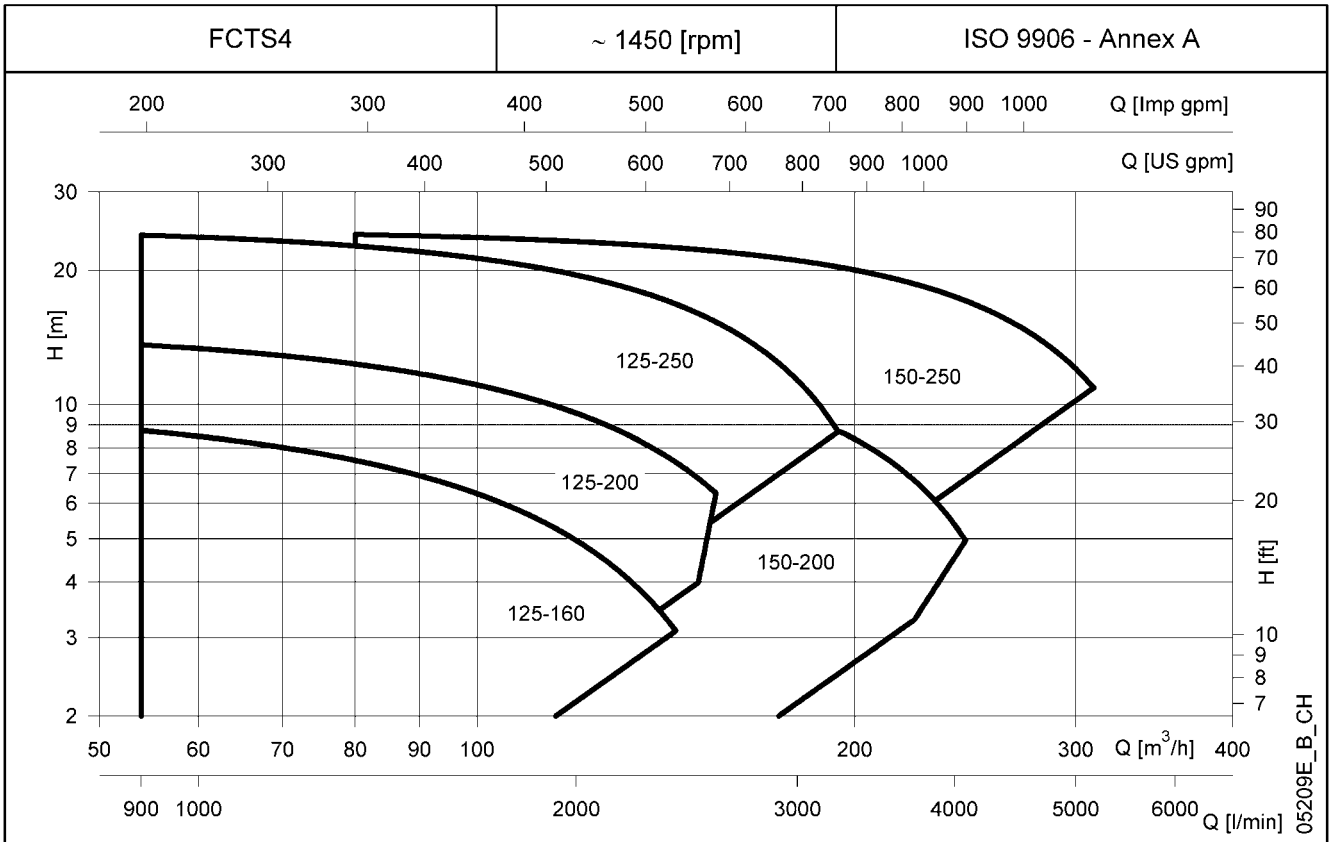

**FCTS4 SERIES (PARALLEL OPERATION)
HYDRAULIC PERFORMANCE RANGE AT 50 Hz, 4 POLES**

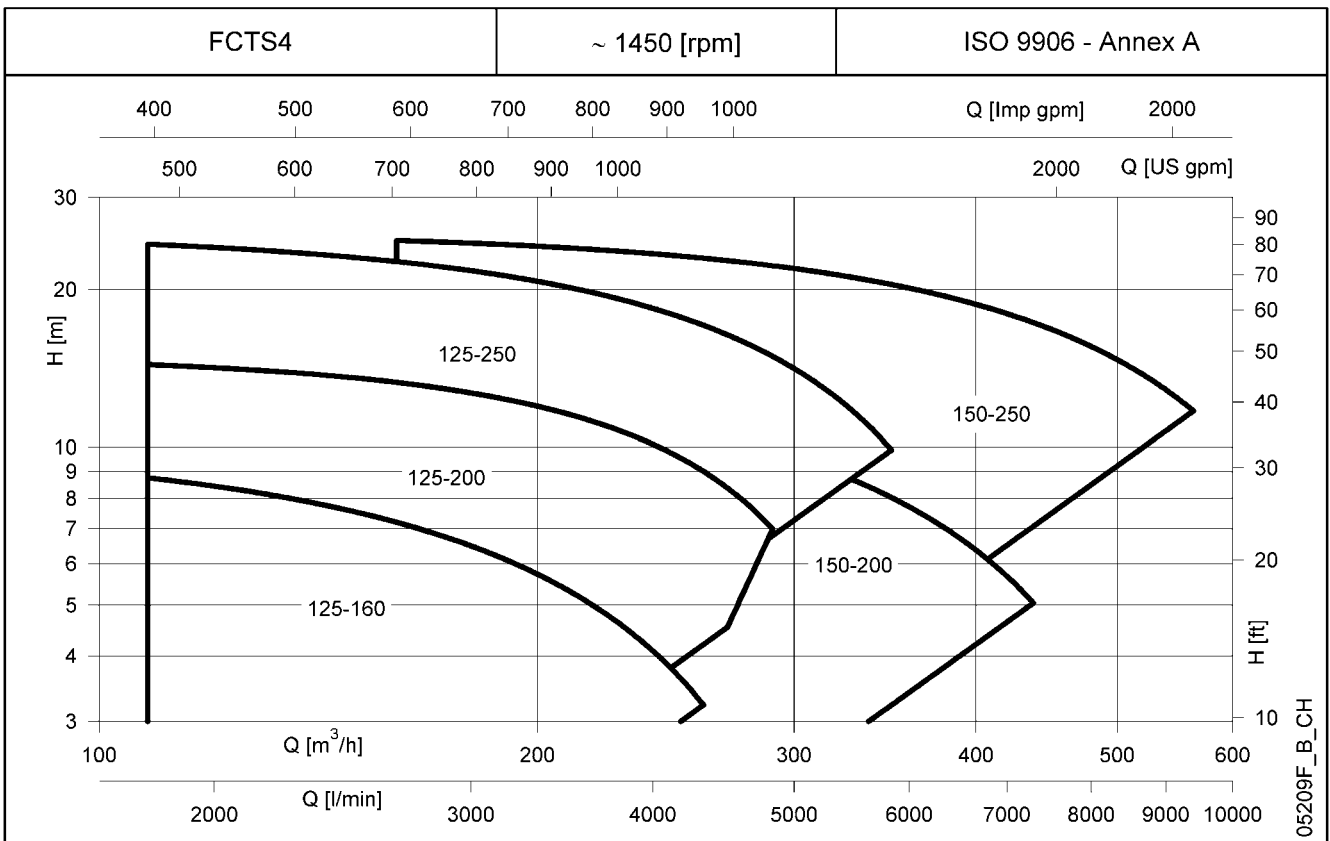

These performances are valid for liquids with density $\rho = 1,0 \text{ Kg/dm}^3$ and kinematic viscosity $\nu = 1 \text{ mm}^2/\text{sec}$.

FCTS4 SERIES (SINGLE OPERATION) HYDRAULIC PERFORMANCE TABLE AT 50 Hz, 4 POLES

PUMP TYPE	RATED POWER		Q = DELIVERY																	
			l/min 0	900	1100	1333	1583	1667	1833	1917	2000	2333	2500	3000	3167	3667	4083	4500	4733	5167
	kW	HP	m ³ /h 0	54	66	80	95	100	110	115	120	140	150	180	190	220	245	270	284	310
H = TOTAL HEAD METRES COLUMN OF WATER																				
125-160/30	3	4	10,1	8,7	8,2	7,5	6,6	6,3	5,7	5,3	5,0	3,4								
125-200/40	4	5,5	12,4	10,9	10,4	9,6	8,6	8,3	7,5	7,1	6,7	5,0	4,0							
125-200/55	5,5	7,5	15,0	13,6	13,1	12,3	11,4	11,1	10,3	10,0	9,6	7,8	6,8							
125-250/75	7,5	10	19,9	18,5	17,9	17,0	15,8	15,4	14,5	14,0	13,4	11,1	9,7							
125-250/110	11	15	25,5	24,0	23,5	22,7	21,7	21,3	20,5	20,0	19,5	17,3	16,0	11,3	9,5					
150-200/55	5,5	7,5	11,8			9,6	9,1	9,0	8,6	8,5	8,3	7,5	7,1	5,7	5,2	3,5				
150-200/75	7,5	10	15,4			13,3	12,9	12,8	12,5	12,3	12,1	11,4	11,0	9,5	9,0	7,0	5,0			
150-250/110	11	15	18,0			17,0	16,7	16,6	16,3	16,1	16,0	15,2	14,8	13,1	12,5	10,2				
150-250/150	15	20	22,1			21,3	21,0	20,8	20,5	20,4	20,2	19,4	19,0	17,5	17,0	15,0	13,2	11,1	9,8	
150-250/185	18,5	25	25,1			24,1	23,8	23,7	23,5	23,3	23,2	22,6	22,3	21,1	20,6	18,9	17,1	15,0	13,7	10,9

Performances according to ISO 9906 - Annex A

lmz-fcts4-4p50S-en_b_th

FCTS4 SERIES (PARALLEL OPERATION) HYDRAULIC PERFORMANCE TABLE AT 50 Hz, 4 POLES

PUMP TYPE	RATED POWER		Q = DELIVERY																	
			l/min 0	1800	2200	2667	3000	3250	3500	3750	4000	4333	4833	5200	5667	6500	7333	7667	8333	9000
	kW	HP	m ³ /h 0	108	132	160	180	195	210	225	240	260	290	312	340	390	440	460	500	540
H = TOTAL HEAD METRES COLUMN OF WATER																				
125-160/30	3	4	10,2	8,8	8,1	7,2	6,5	5,9	5,3	4,7	4,1	3,2								
125-200/40	4	5,5	12,7	11,2	10,6	9,7	9,0	8,4	7,8	7,1	6,3	5,2								
125-200/55	5,5	7,5	15,1	14,4	14,0	13,3	12,7	12,2	11,6	10,9	10,1	9,0	7,0							
125-250/75	7,5	10	20,3	17,8	17,2	16,4	15,6	15,0	14,2	13,4	12,4	10,9	8,2							
125-250/110	11	15	25,6	24,4	23,7	22,6	21,7	21,0	20,2	19,3	18,4	17,1	14,9	13,2	10,8					
150-200/55	5,5	7,5	11,6				8,6	8,2	7,9	7,5	7,1	6,6	5,8	5,2	4,5					
150-200/75	7,5	10	15,4				12,7	12,4	12,0	11,6	11,2	10,7	9,9	9,2	8,3	6,7				
150-250/110	11	15	18,7				17,2	16,9	16,6	16,3	16,0	15,5	14,7	14,0	13,1	11,2	9,0	8,0		
150-250/150	15	20	22,7				21,5	21,3	21,0	20,7	20,4	20,0	19,2	18,6	17,7	15,9	13,8	12,9	10,9	
150-250/185	18,5	25	25,4				24,5	24,3	24,0	23,7	23,4	23,0	22,2	21,6	20,8	19,1	17,2	16,4	14,7	12,9

Performances according to ISO 9906 - Annex A

lmz-fcts4-4p50P-en_c_th

FCTE-FCTS SERIES OPERATING CHARACTERISTICS AT 50 Hz, 2 POLES

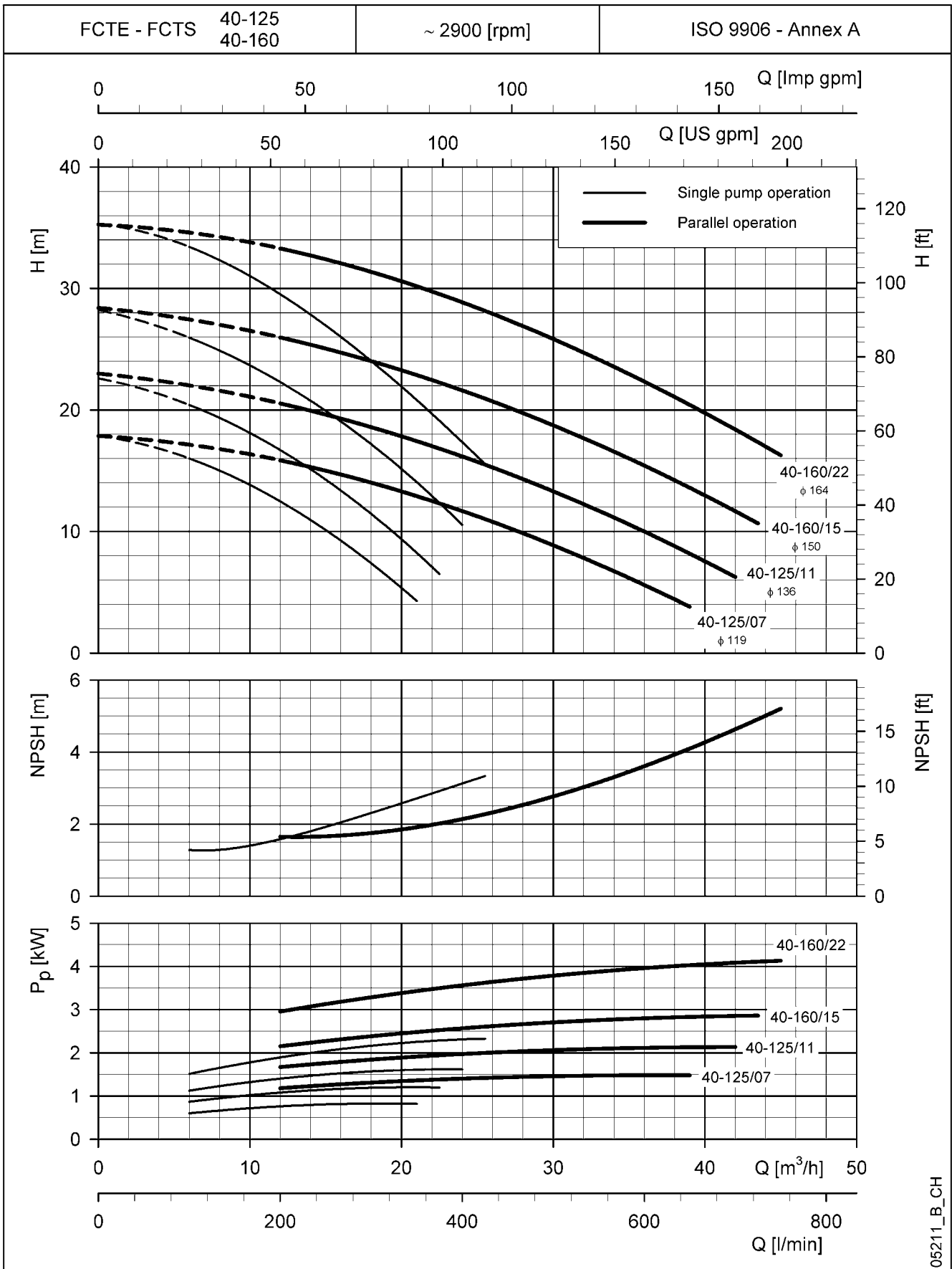

05211_B_CH

The NPSH values are laboratory values; for practical use we suggest increasing these values by 0,5 m.
These performances are valid for liquids with density $\rho = 1,0 \text{ Kg/dm}^3$ and kinematic viscosity $\nu = 1 \text{ mm}^2/\text{sec}$.

**FCTE-FCTS SERIES
OPERATING CHARACTERISTICS AT 50 Hz, 2 POLES**

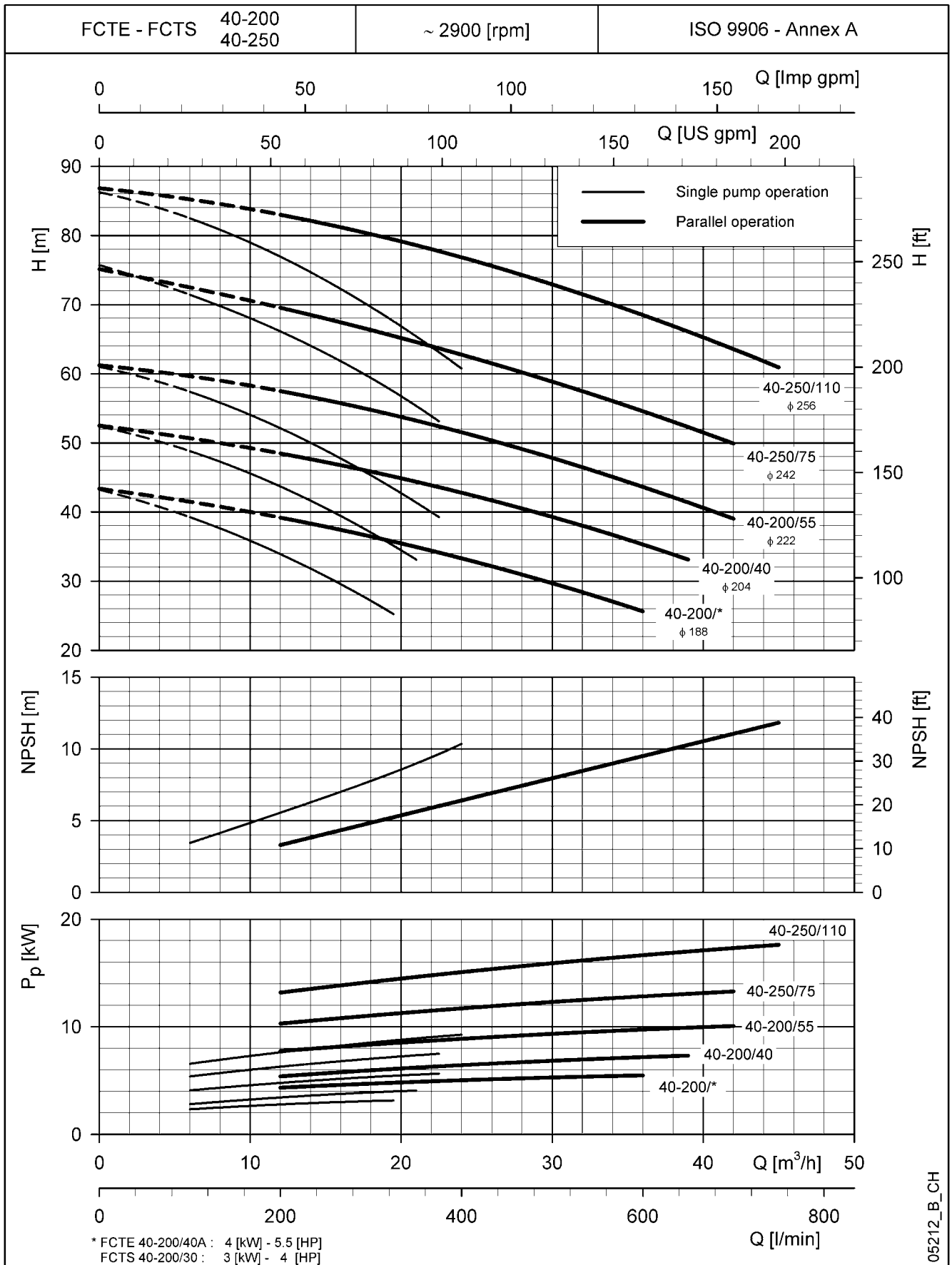

The NPSH values are laboratory values; for practical use we suggest increasing these values by 0,5 m.
 These performances are valid for liquids with density $\rho = 1,0 \text{ Kg/dm}^3$ and kinematic viscosity $\nu = 1 \text{ mm}^2/\text{sec}$.

**FCTE-FCTS SERIES
OPERATING CHARACTERISTICS AT 50 Hz, 2 POLES**

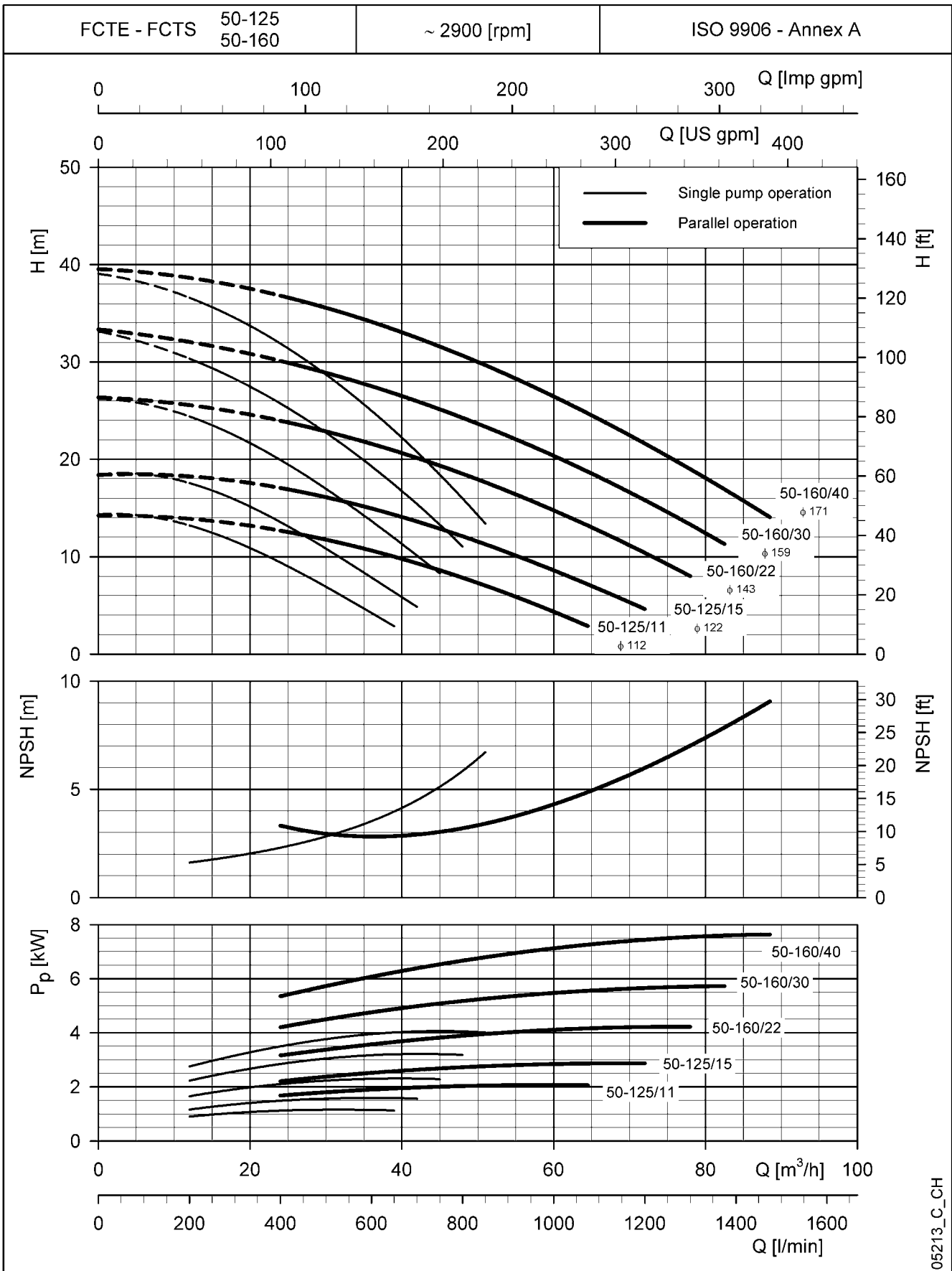

05213_C_CH

The NPSH values are laboratory values; for practical use we suggest increasing these values by 0,5 m.
These performances are valid for liquids with density $\rho = 1,0 \text{ Kg/dm}^3$ and kinematic viscosity $\nu = 1 \text{ mm}^2/\text{sec}$.

FCTE-FCTS SERIES
OPERATING CHARACTERISTICS AT 50 Hz, 2 POLES

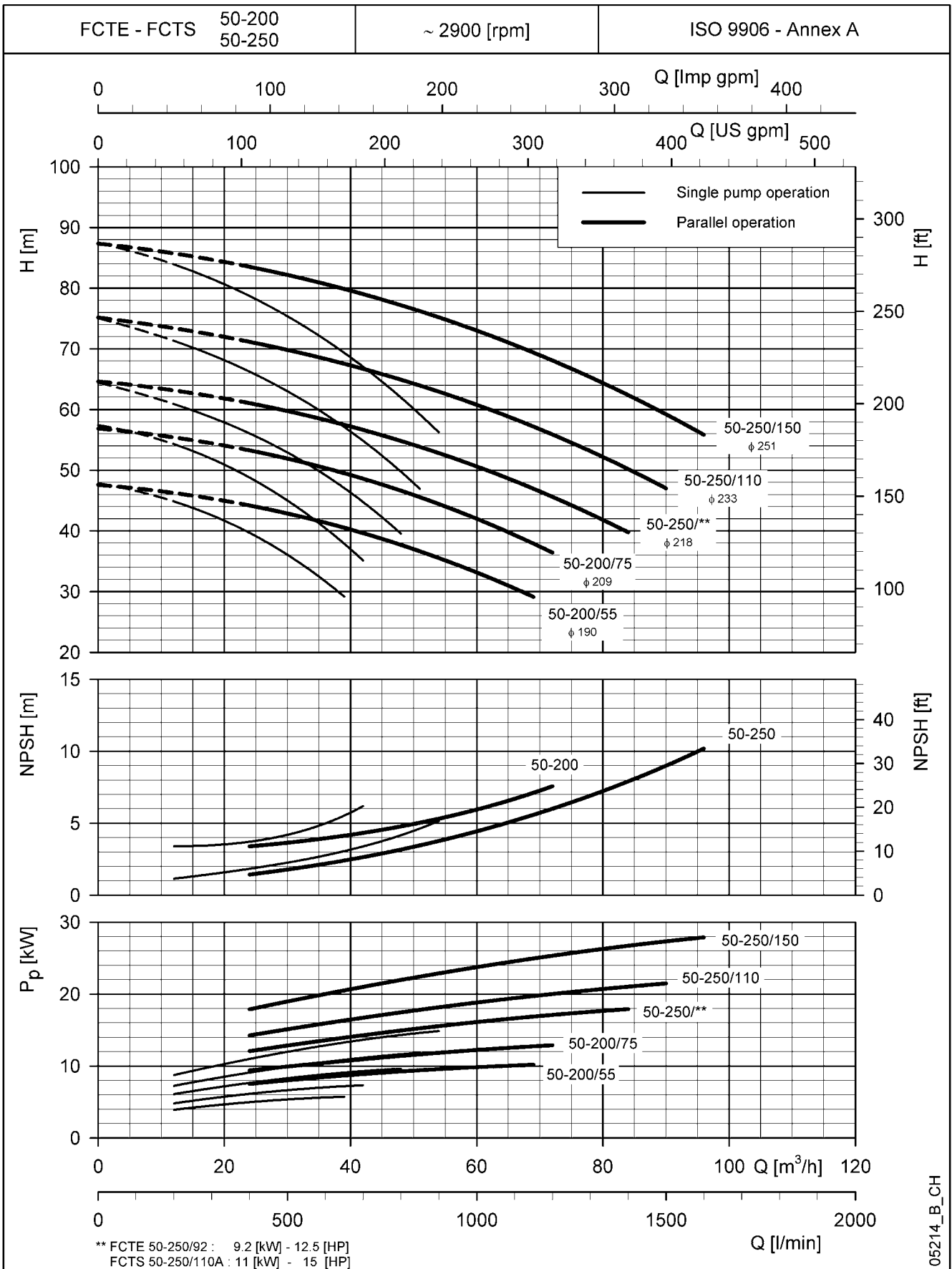

The NPSH values are laboratory values; for practical use we suggest increasing these values by 0,5 m.
These performances are valid for liquids with density $\rho = 1,0 \text{ Kg/dm}^3$ and kinematic viscosity $\nu = 1 \text{ mm}^2/\text{sec}$.

FCTE-FCTS SERIES
OPERATING CHARACTERISTICS AT 50 Hz, 2 POLES

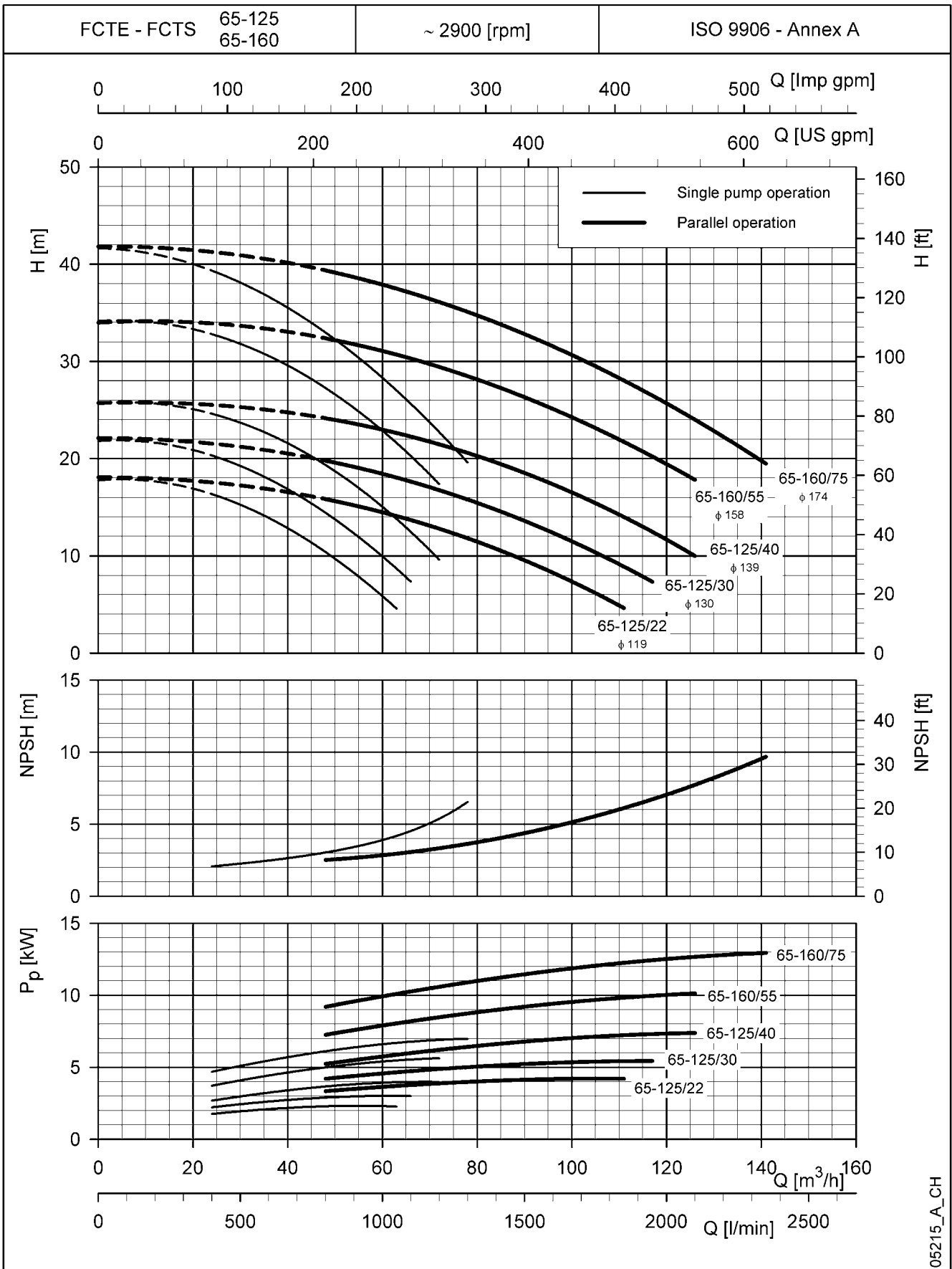

05215_A_CH

The NPSH values are laboratory values; for practical use we suggest increasing these values by 0,5 m.
These performances are valid for liquids with density $\rho = 1,0 \text{ Kg/dm}^3$ and kinematic viscosity $\nu = 1 \text{ mm}^2/\text{sec}$.

**FCTE-FCTS SERIES
OPERATING CHARACTERISTICS AT 50 Hz, 2 POLES**

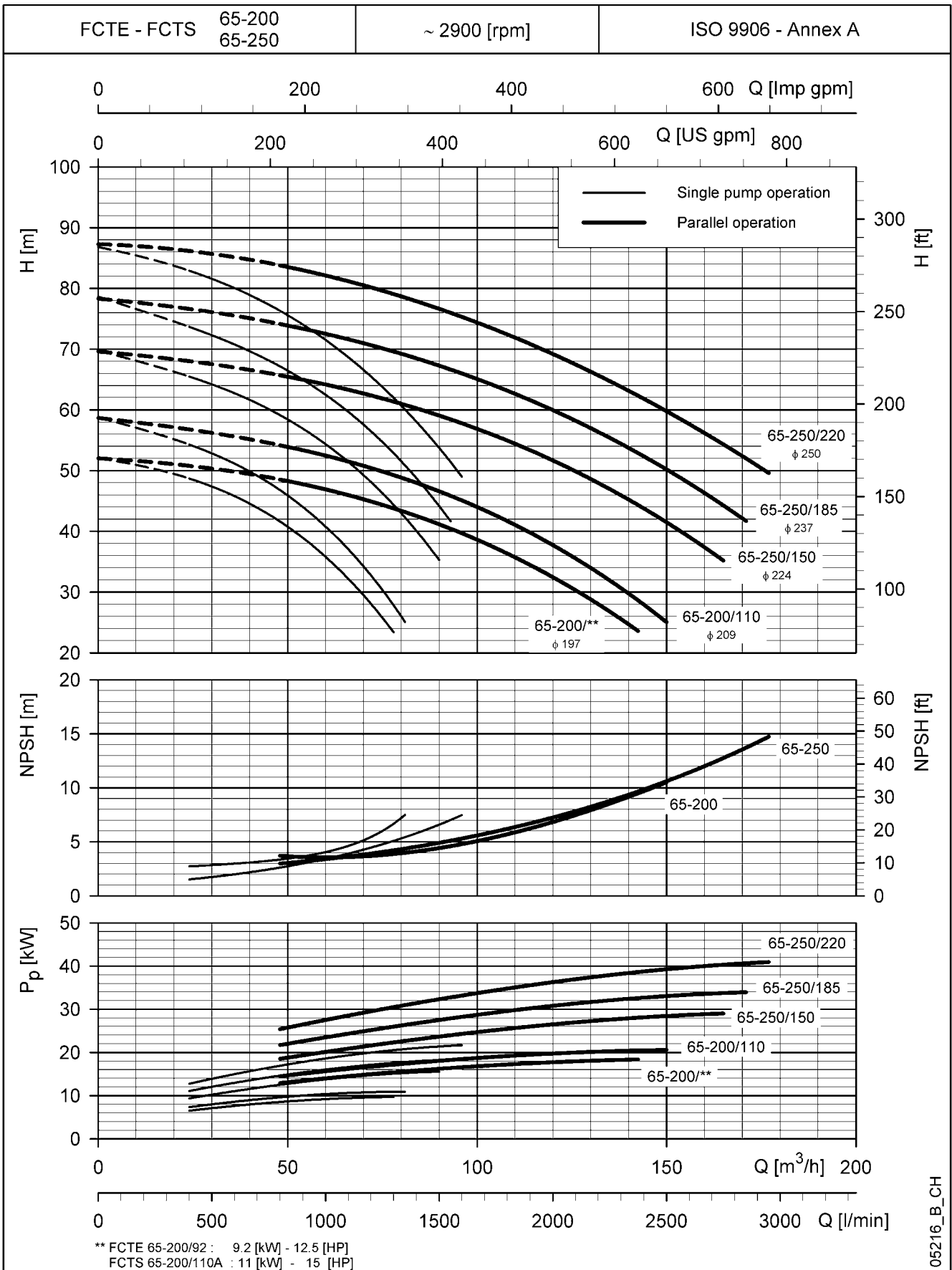

The NPSH values are laboratory values; for practical use we suggest increasing these values by 0,5 m.
 These performances are valid for liquids with density $\rho = 1,0 \text{ Kg/dm}^3$ and kinematic viscosity $\nu = 1 \text{ mm}^2/\text{sec}$.

**FCTE-FCTS SERIES
OPERATING CHARACTERISTICS AT 50 Hz, 2 POLES**

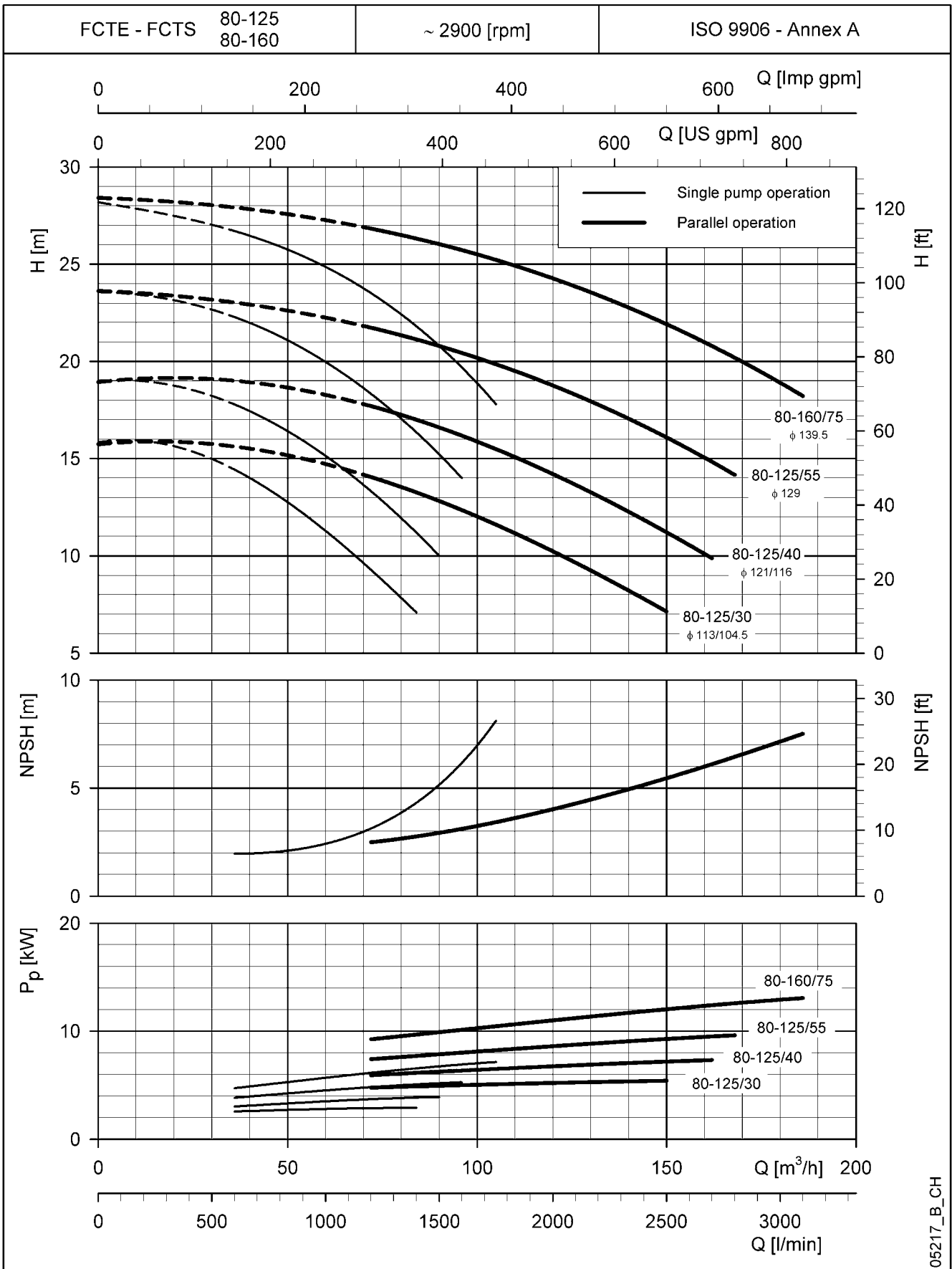

05217_B_CH

The NPSH values are laboratory values; for practical use we suggest increasing these values by 0,5 m.
These performances are valid for liquids with density $\rho = 1,0 \text{ Kg/dm}^3$ and kinematic viscosity $\nu = 1 \text{ mm}^2/\text{sec}$.

**FCTE-FCTS SERIES
OPERATING CHARACTERISTICS AT 50 Hz, 2 POLES**

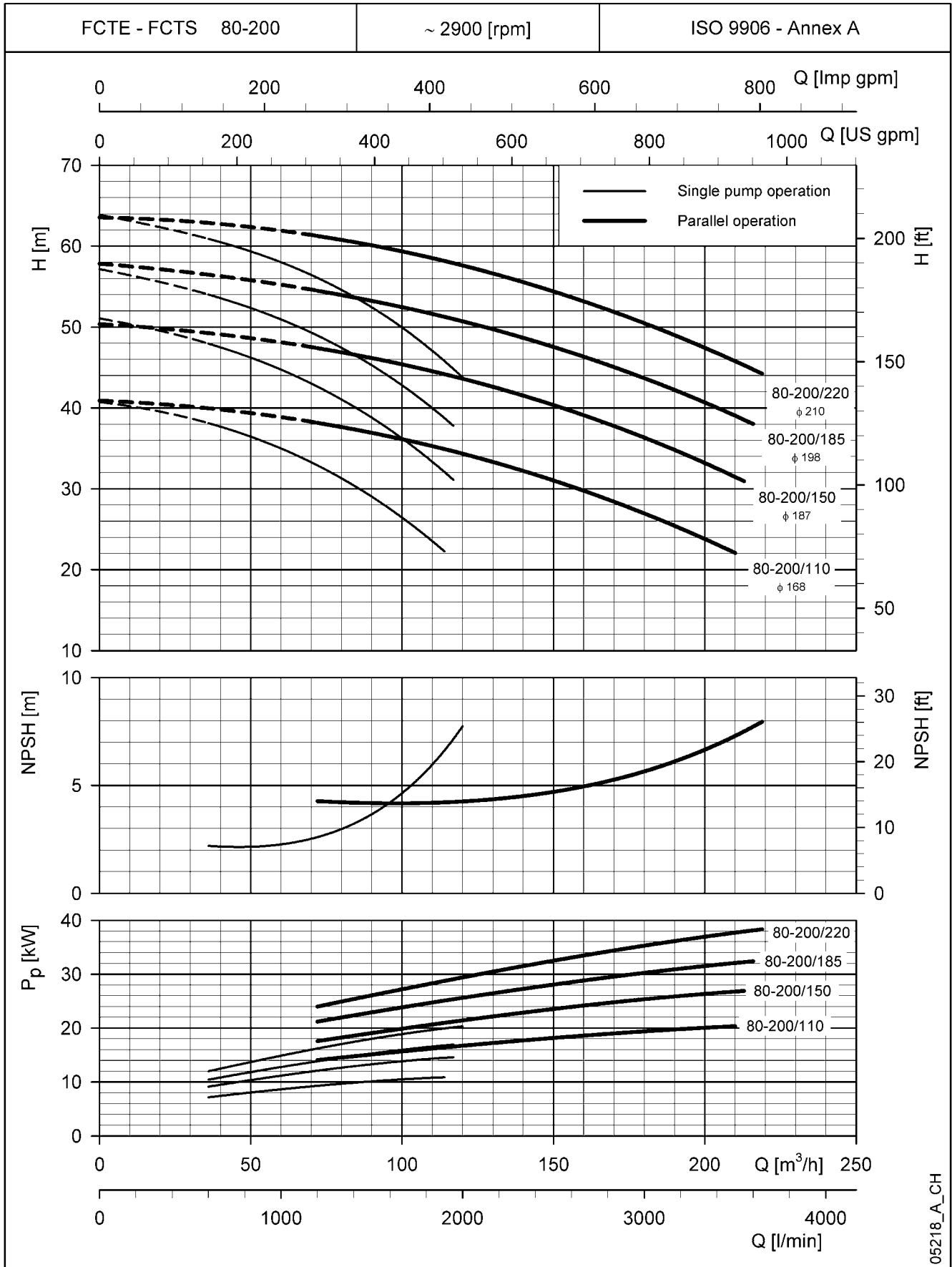

05218_A_CH

The NPSH values are laboratory values; for practical use we suggest increasing these values by 0,5 m.
 These performances are valid for liquids with density $\rho = 1,0 \text{ Kg/dm}^3$ and kinematic viscosity $\nu = 1 \text{ mm}^2/\text{sec}$.

**FCTE-FCTS SERIES
OPERATING CHARACTERISTICS AT 50 Hz, 2 POLES**

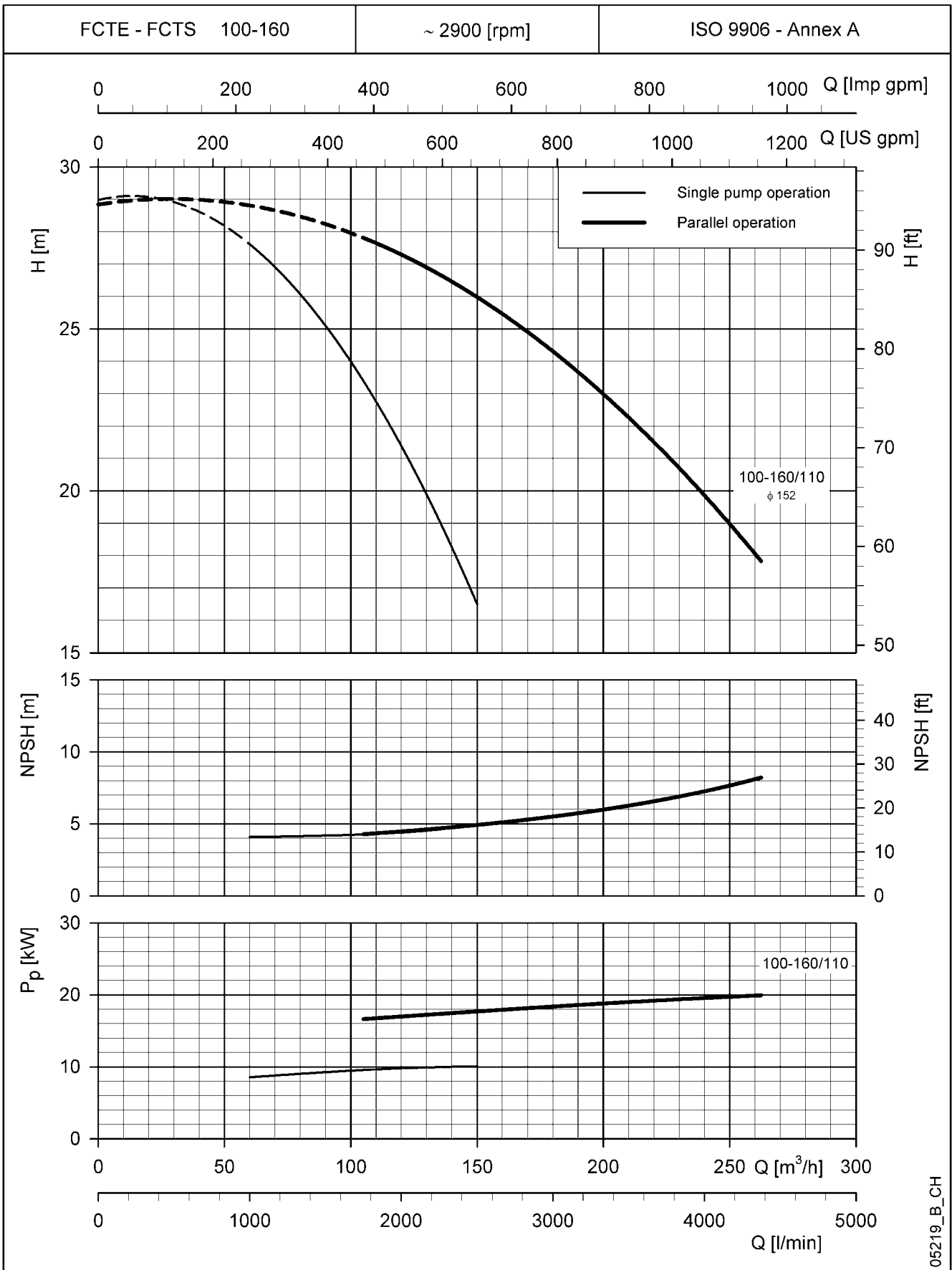

The NPSH values are laboratory values; for practical use we suggest increasing these values by 0,5 m.
These performances are valid for liquids with density $\rho = 1,0 \text{ Kg/dm}^3$ and kinematic viscosity $\nu = 1 \text{ mm}^2/\text{sec}$.

**FCTE-FCTS SERIES
OPERATING CHARACTERISTICS AT 50 Hz, 2 POLES**

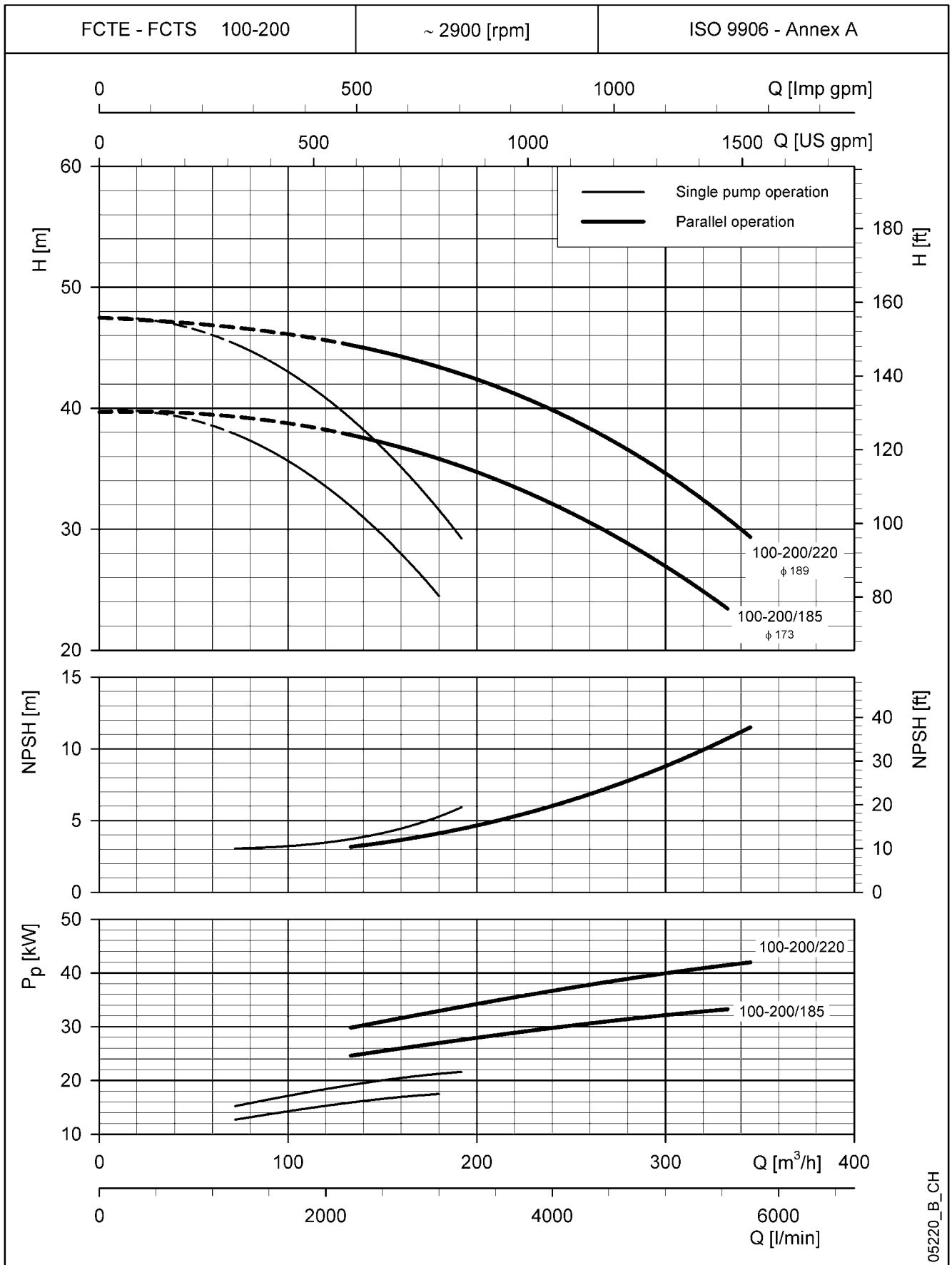

The NPSH values are laboratory values; for practical use we suggest increasing these values by 0,5 m.
 These performances are valid for liquids with density $\rho = 1,0 \text{ Kg/dm}^3$ and kinematic viscosity $\nu = 1 \text{ mm}^2/\text{sec}$.

**FCTE4 SERIES
OPERATING CHARACTERISTICS AT 50 Hz, 4 POLES**

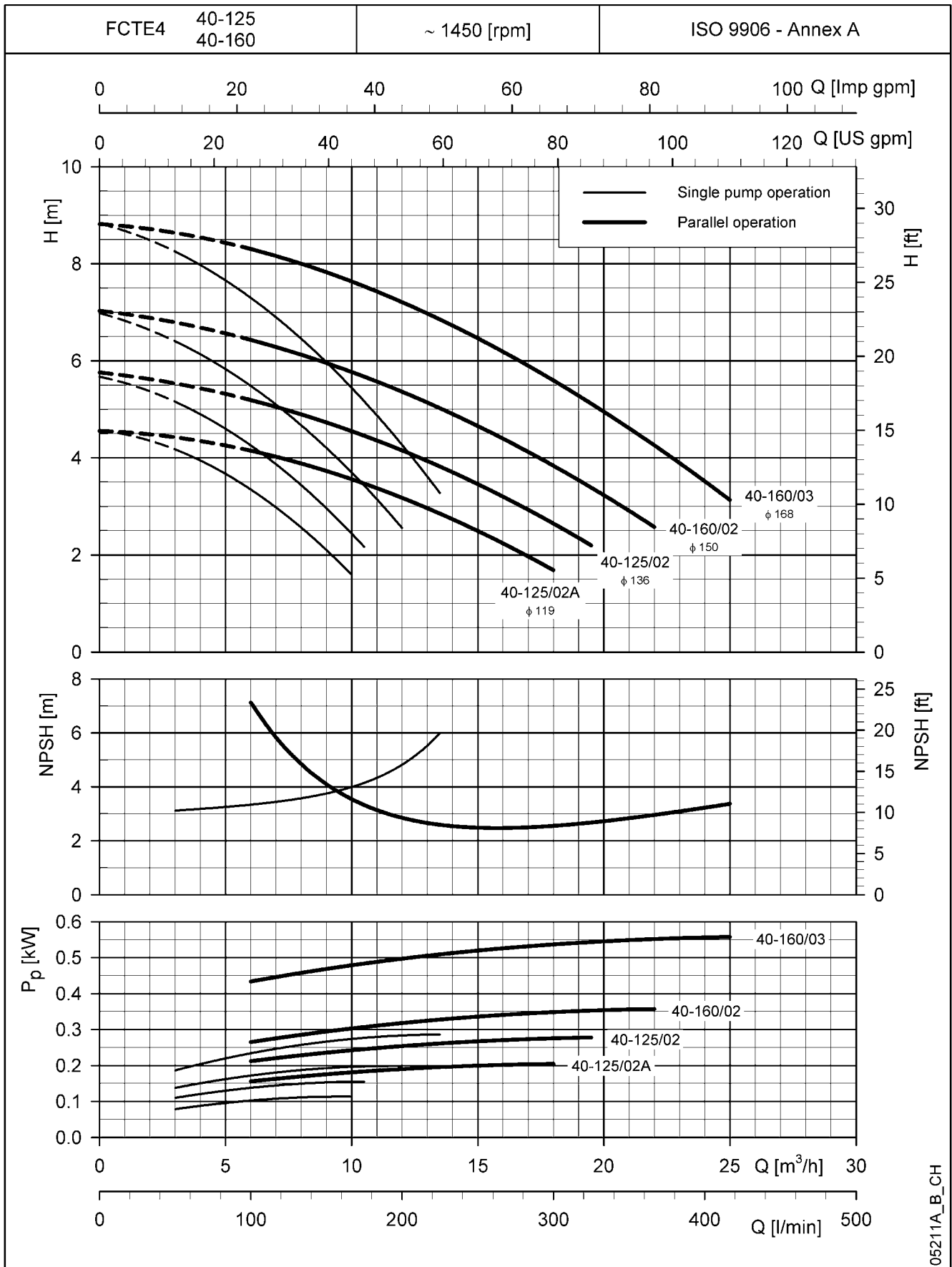

05211A_B_CH

The NPSH values are laboratory values; for practical use we suggest increasing these values by 0,5 m.
 These performances are valid for liquids with density $\rho = 1,0 \text{ Kg/dm}^3$ and kinematic viscosity $\nu = 1 \text{ mm}^2/\text{sec}$.

**FCTE4-FCTS4 SERIES
OPERATING CHARACTERISTICS AT 50 Hz, 4 POLES**

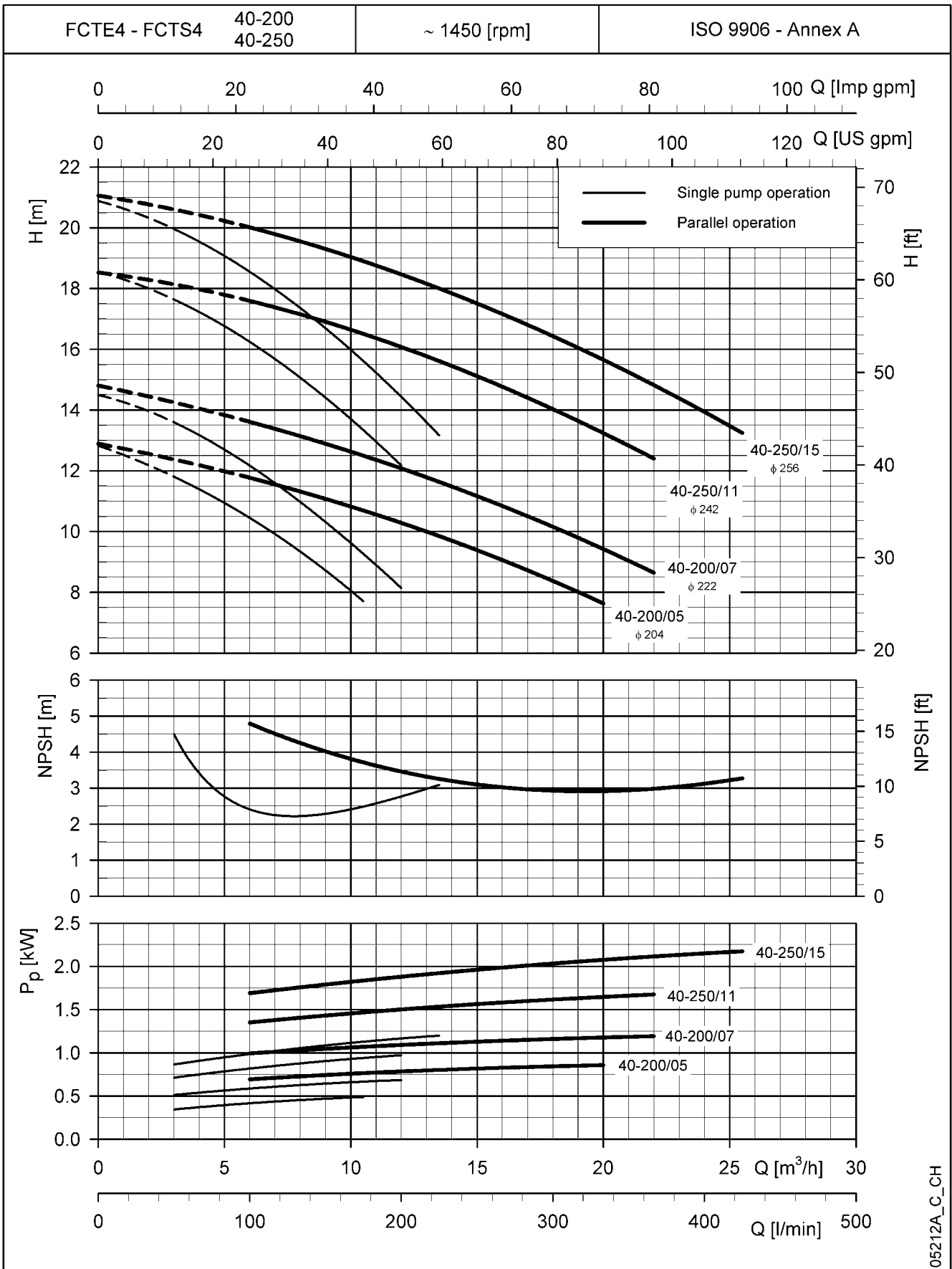

05212A_C_CH

The NPSH values are laboratory values; for practical use we suggest increasing these values by 0,5 m.
 These performances are valid for liquids with density $\rho = 1,0 \text{ Kg/dm}^3$ and kinematic viscosity $\nu = 1 \text{ mm}^2/\text{sec}$.

**FCTE4 SERIES
OPERATING CHARACTERISTICS AT 50 Hz, 4 POLES**

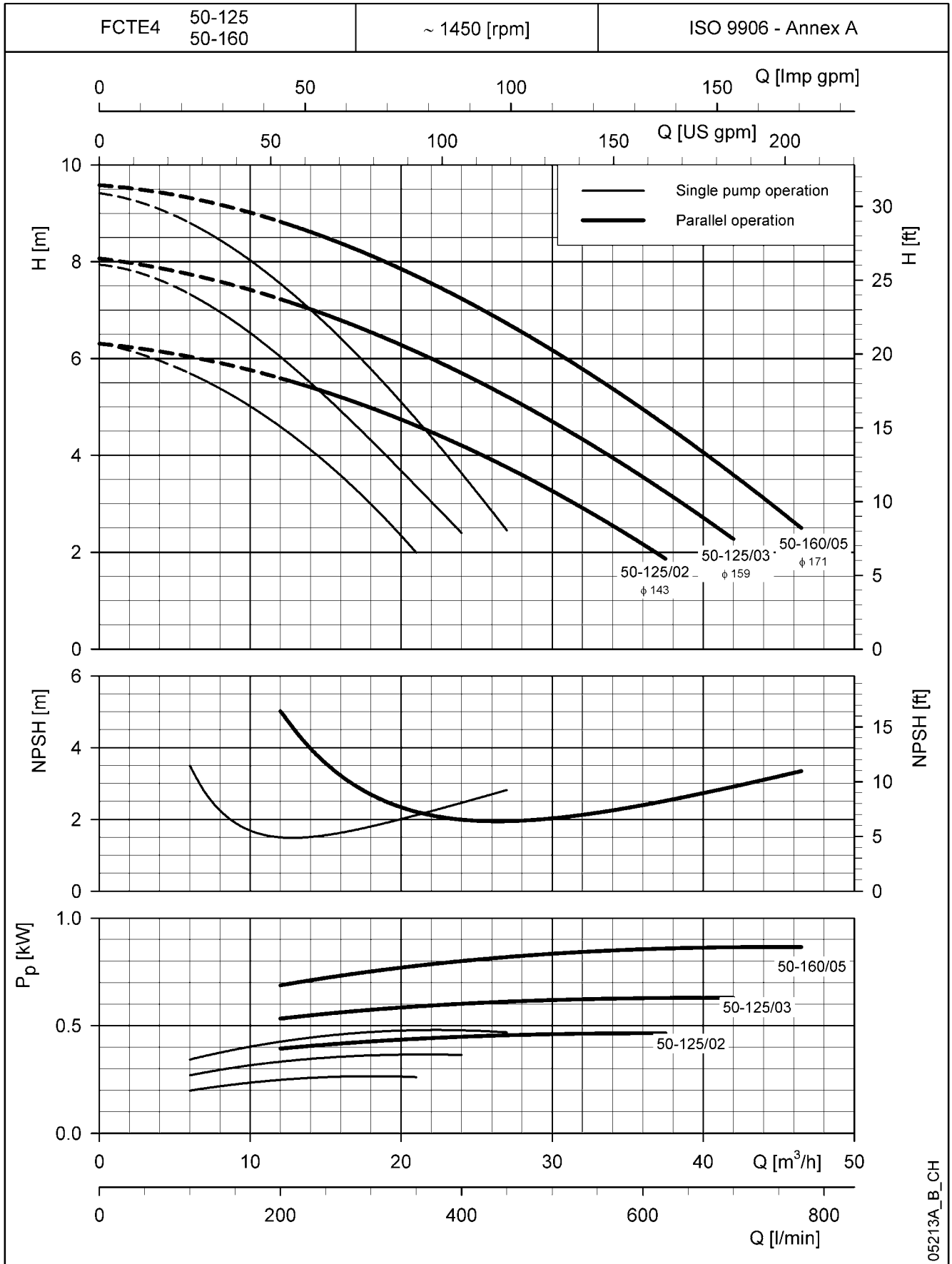

05213A_B_CH

The NPSH values are laboratory values; for practical use we suggest increasing these values by 0,5 m.
These performances are valid for liquids with density $\rho = 1,0 \text{ Kg/dm}^3$ and kinematic viscosity $\nu = 1 \text{ mm}^2/\text{sec}$.

FCTE4-FCTS4 SERIES OPERATING CHARACTERISTICS AT 50 Hz, 4 POLES

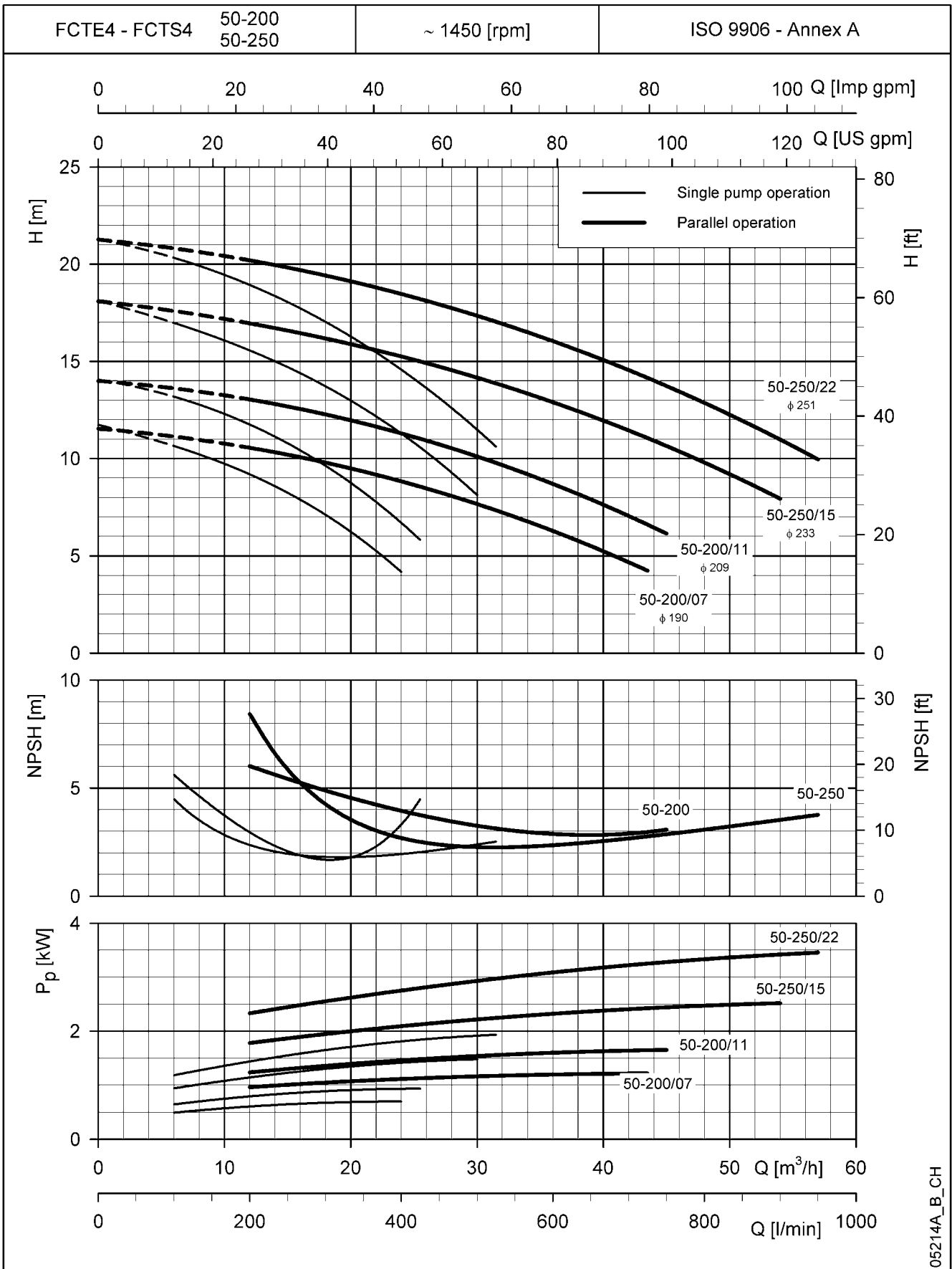

05214A_B_CH

The NPSH values are laboratory values; for practical use we suggest increasing these values by 0,5 m.
 These performances are valid for liquids with density $\rho = 1,0 \text{ Kg/dm}^3$ and kinematic viscosity $\nu = 1 \text{ mm}^2/\text{sec}$.

**FCTE4-FCTS4 SERIES
OPERATING CHARACTERISTICS AT 50 Hz, 4 POLES**

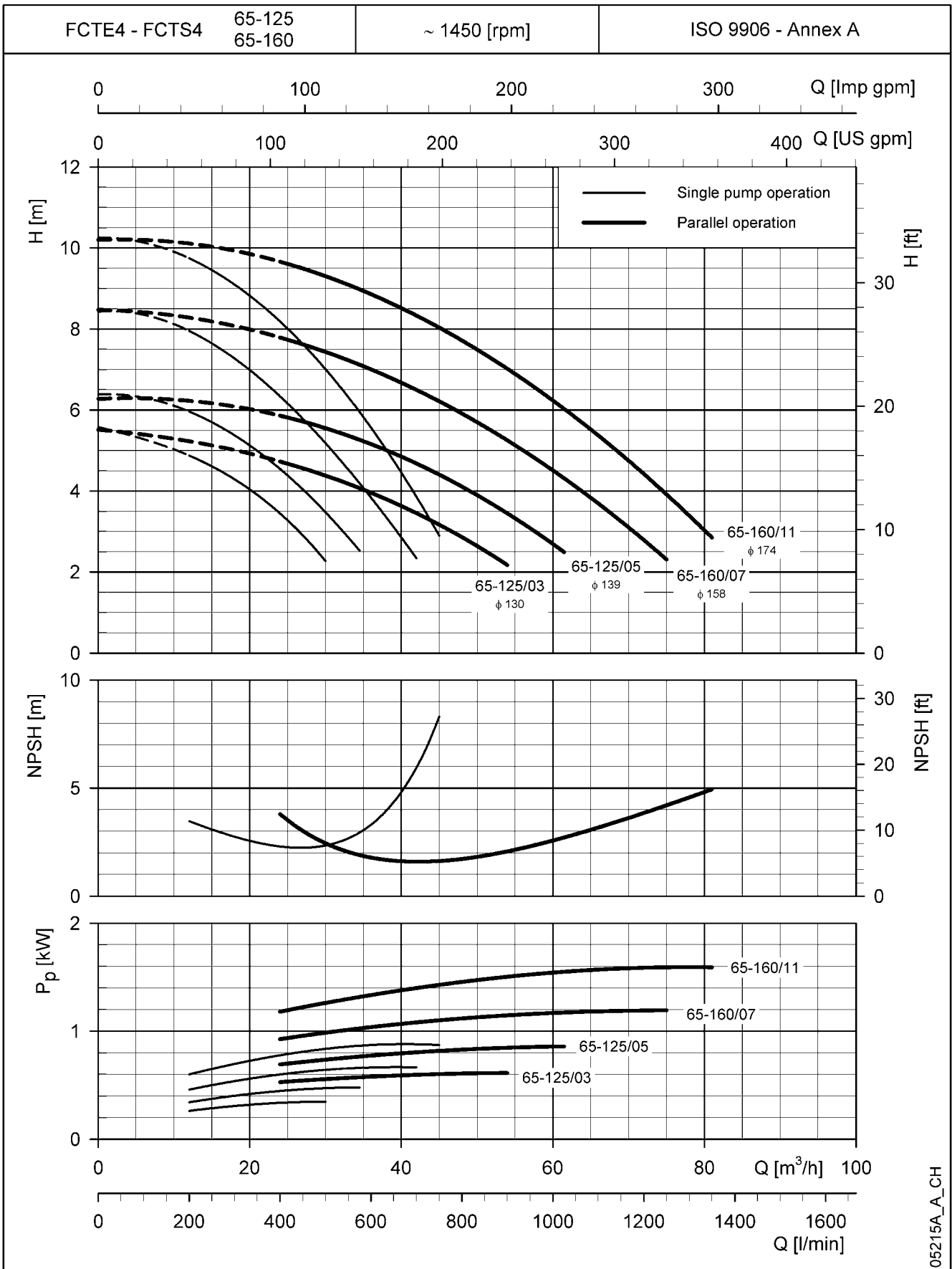

05215A_A_CH

The NPSH values are laboratory values; for practical use we suggest increasing these values by 0,5 m.
These performances are valid for liquids with density $\rho = 1,0 \text{ Kg/dm}^3$ and kinematic viscosity $\nu = 1 \text{ mm}^2/\text{sec}$.

**FCTE4-FCTS4 SERIES
OPERATING CHARACTERISTICS AT 50 Hz, 4 POLES**

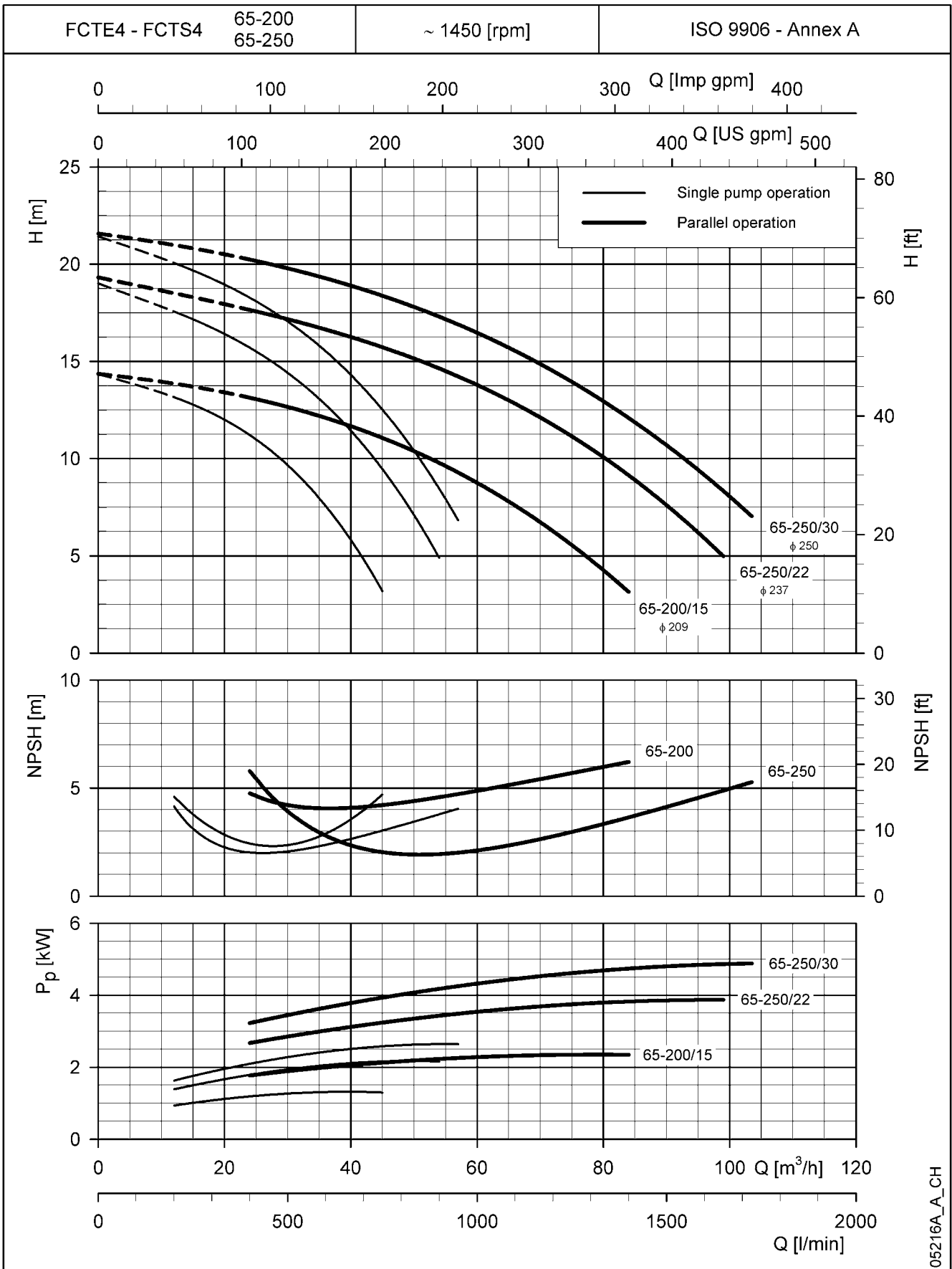

05216A_A_CH

The NPSH values are laboratory values; for practical use we suggest increasing these values by 0,5 m.
These performances are valid for liquids with density $\rho = 1,0 \text{ Kg/dm}^3$ and kinematic viscosity $\nu = 1 \text{ mm}^2/\text{sec}$.

**FCTE4-FCTS4 SERIES
OPERATING CHARACTERISTICS AT 50 Hz, 4 POLES**

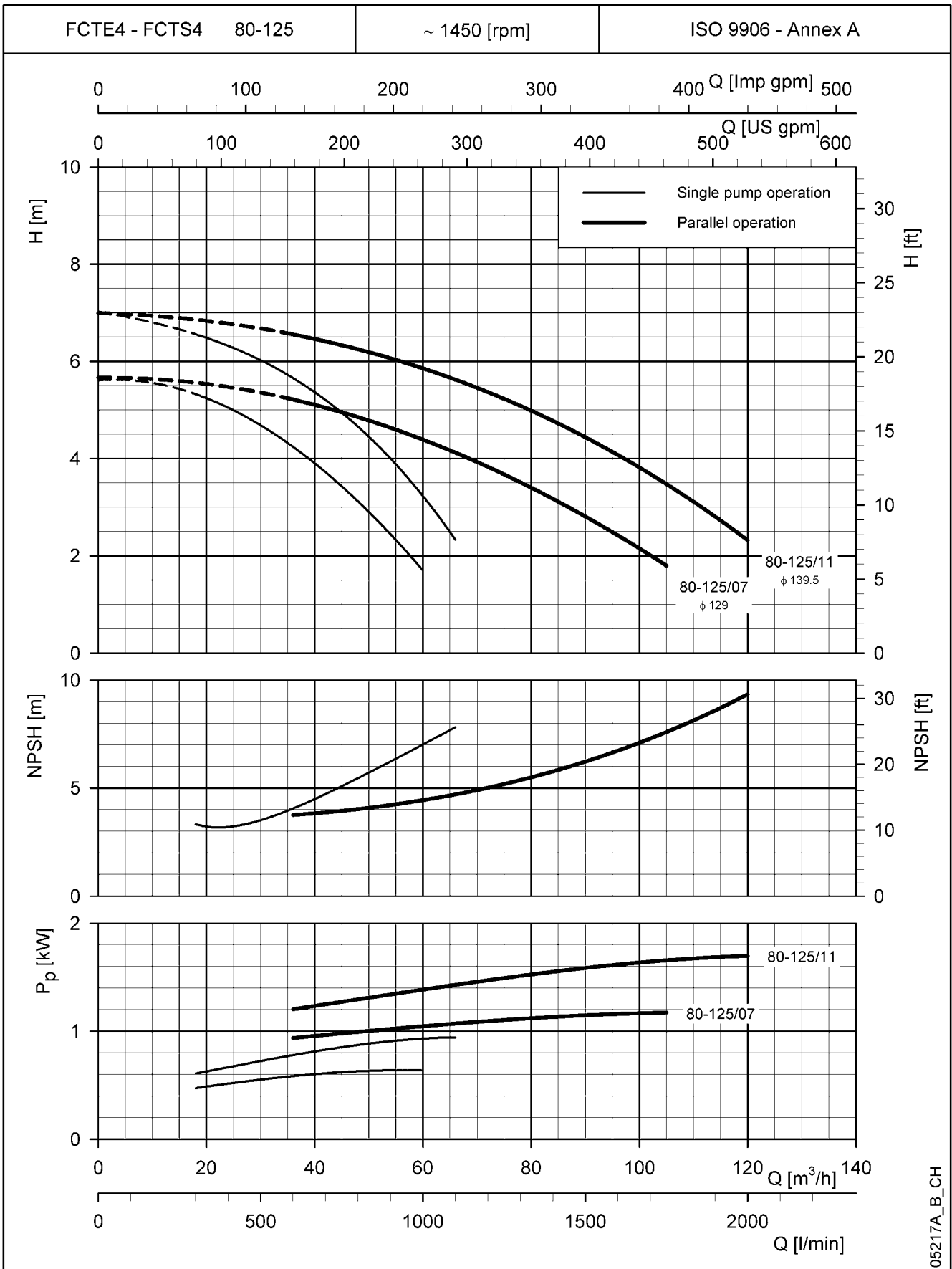

05217A_B_CH

The NPSH values are laboratory values; for practical use we suggest increasing these values by 0,5 m.
These performances are valid for liquids with density $\rho = 1,0 \text{ Kg/dm}^3$ and kinematic viscosity $\nu = 1 \text{ mm}^2/\text{sec}$.

FCTE4-FCTS4 SERIES
OPERATING CHARACTERISTICS AT 50 Hz, 4 POLES

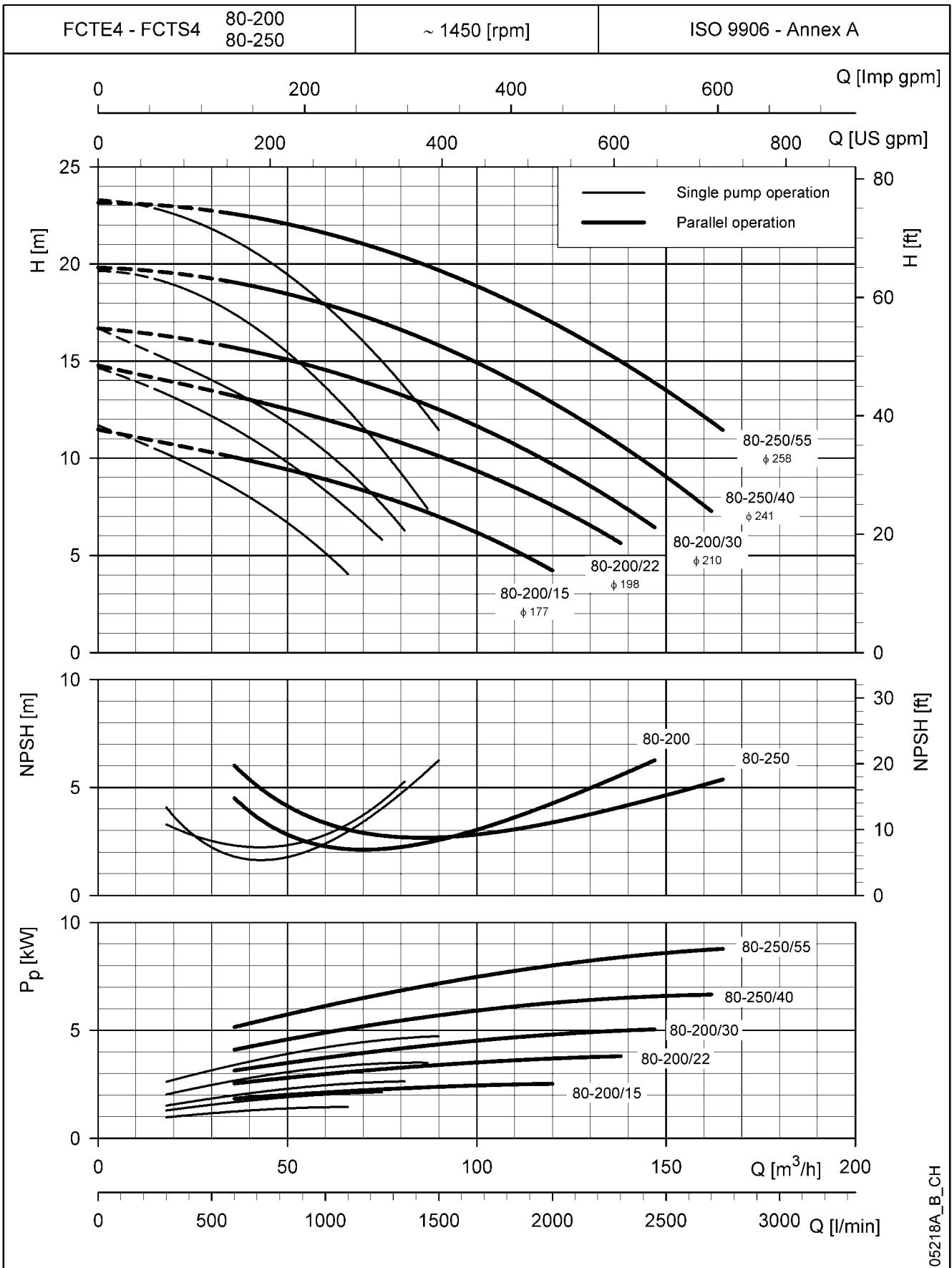

05218A_B_CH

The NPSH values are laboratory values; for practical use we suggest increasing these values by 0,5 m.
 These performances are valid for liquids with density $\rho = 1,0 \text{ Kg/dm}^3$ and kinematic viscosity $\nu = 1 \text{ mm}^2/\text{sec}$.

**FCTE4-FCTS4 SERIES
OPERATING CHARACTERISTICS AT 50 Hz, 4 POLES**

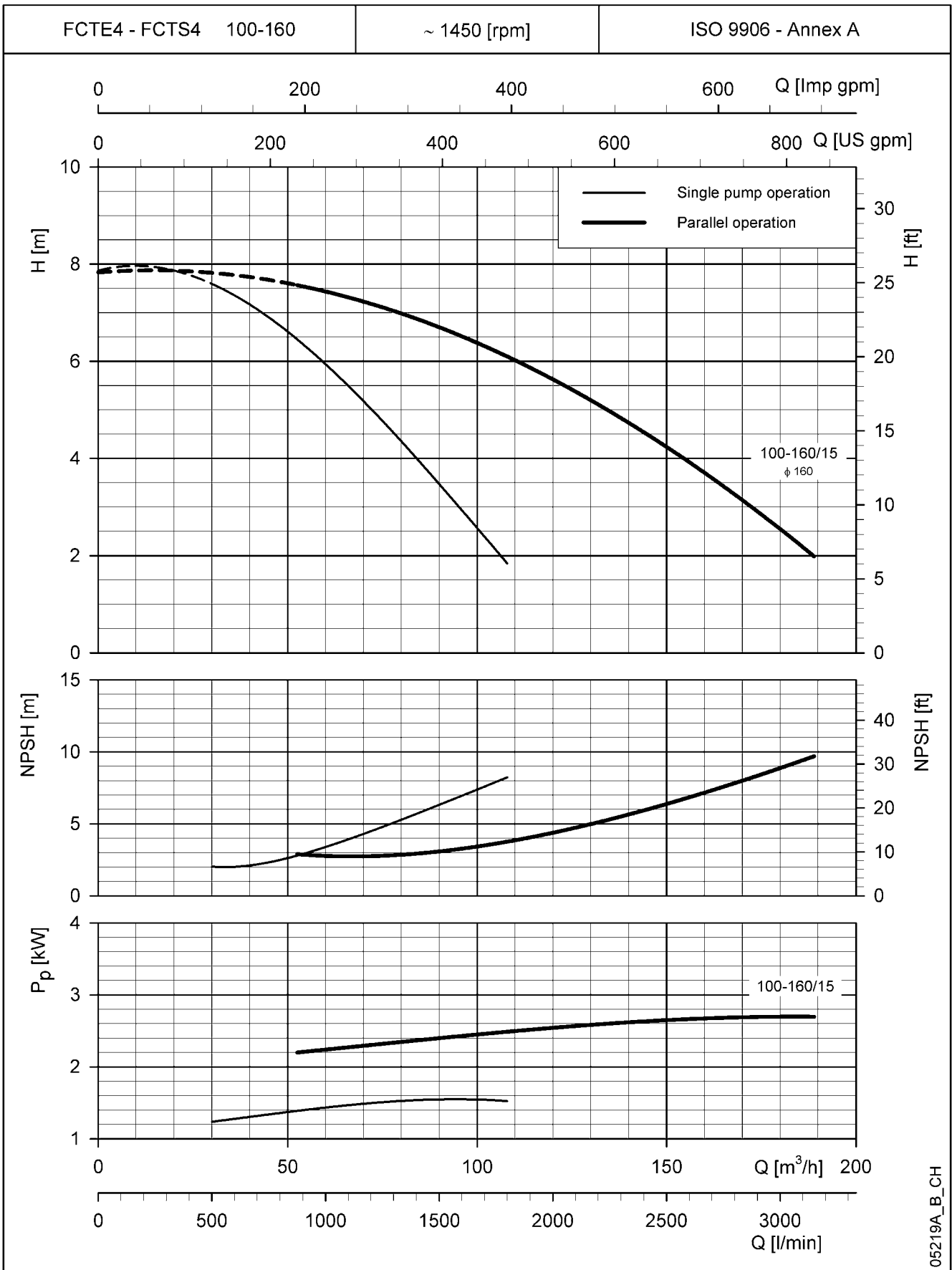

The NPSH values are laboratory values; for practical use we suggest increasing these values by 0,5 m.
These performances are valid for liquids with density $\rho = 1,0 \text{ Kg/dm}^3$ and kinematic viscosity $\nu = 1 \text{ mm}^2/\text{sec}$.

FCTE4-FCTS4 SERIES OPERATING CHARACTERISTICS AT 50 Hz, 4 POLES

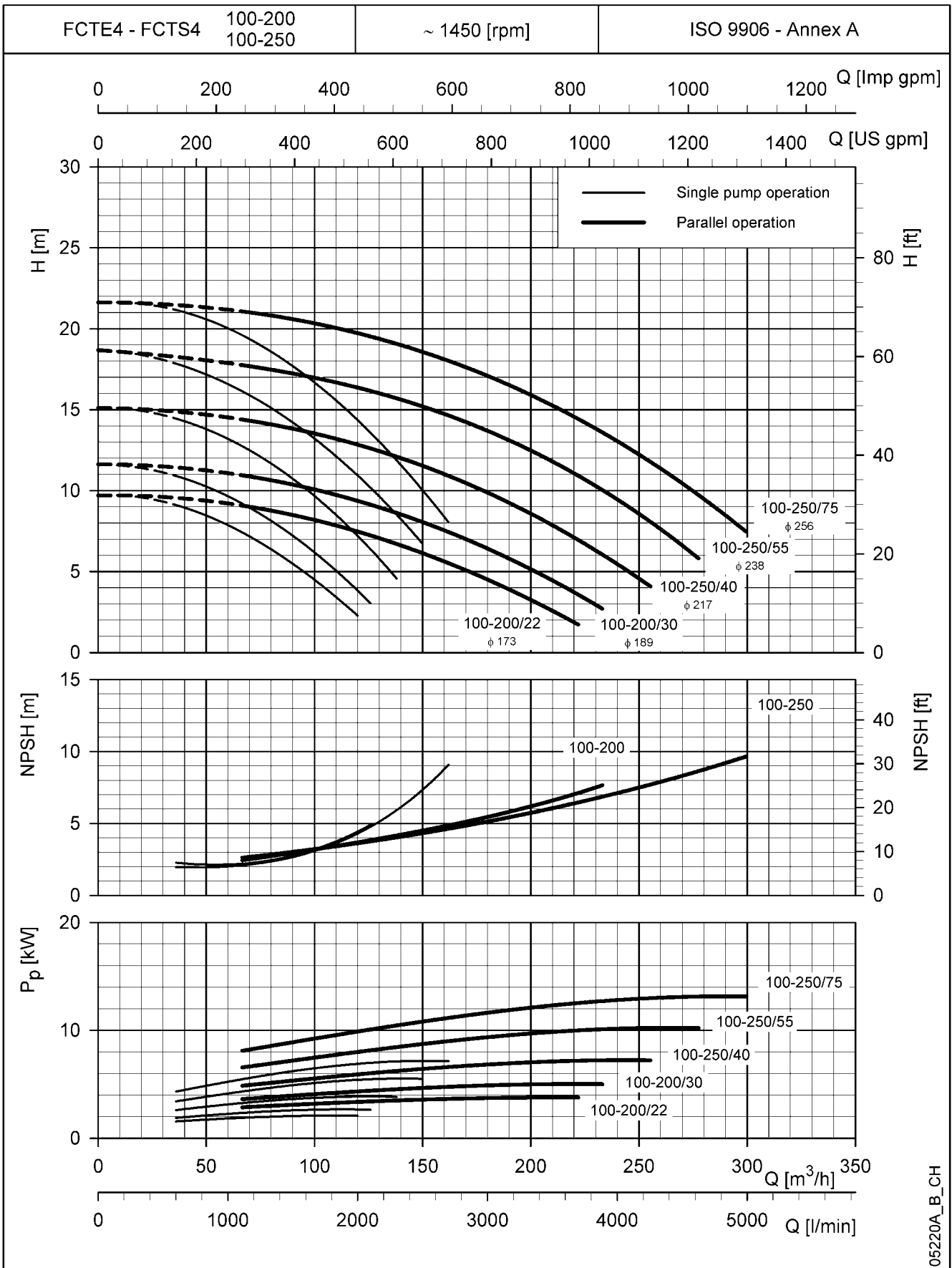

05220A_B_CH

The NPSH values are laboratory values; for practical use we suggest increasing these values by 0,5 m.
These performances are valid for liquids with density $\rho = 1,0 \text{ Kg/dm}^3$ and kinematic viscosity $\nu = 1 \text{ mm}^2/\text{sec}$.

**FCTS4 SERIES
OPERATING CHARACTERISTICS AT 50 Hz, 4 POLES**

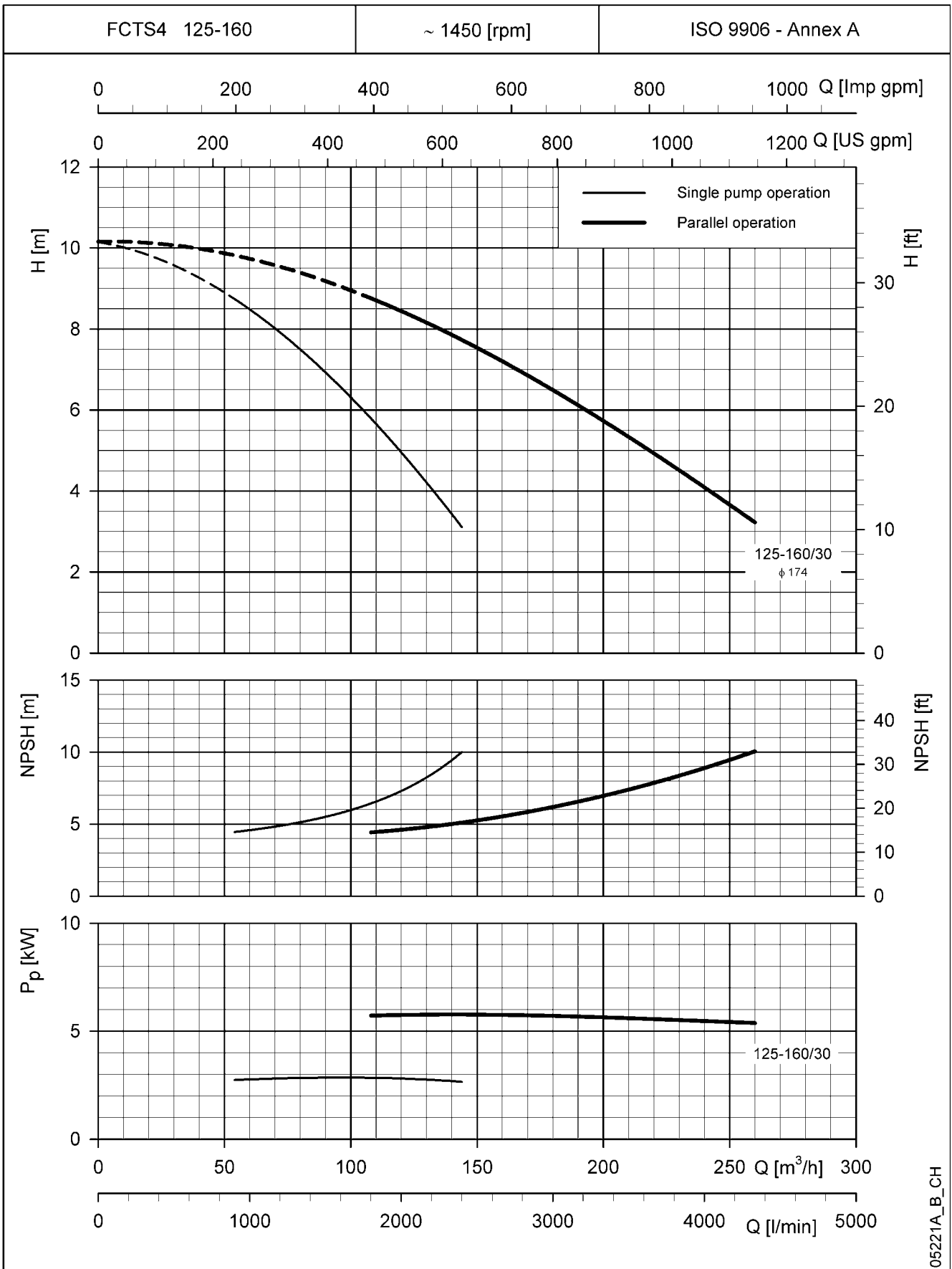

The NPSH values are laboratory values; for practical use we suggest increasing these values by 0,5 m.
These performances are valid for liquids with density $\rho = 1,0 \text{ Kg/dm}^3$ and kinematic viscosity $\nu = 1 \text{ mm}^2/\text{sec}$.

**FCTS4 SERIES
OPERATING CHARACTERISTICS AT 50 Hz, 4 POLES**

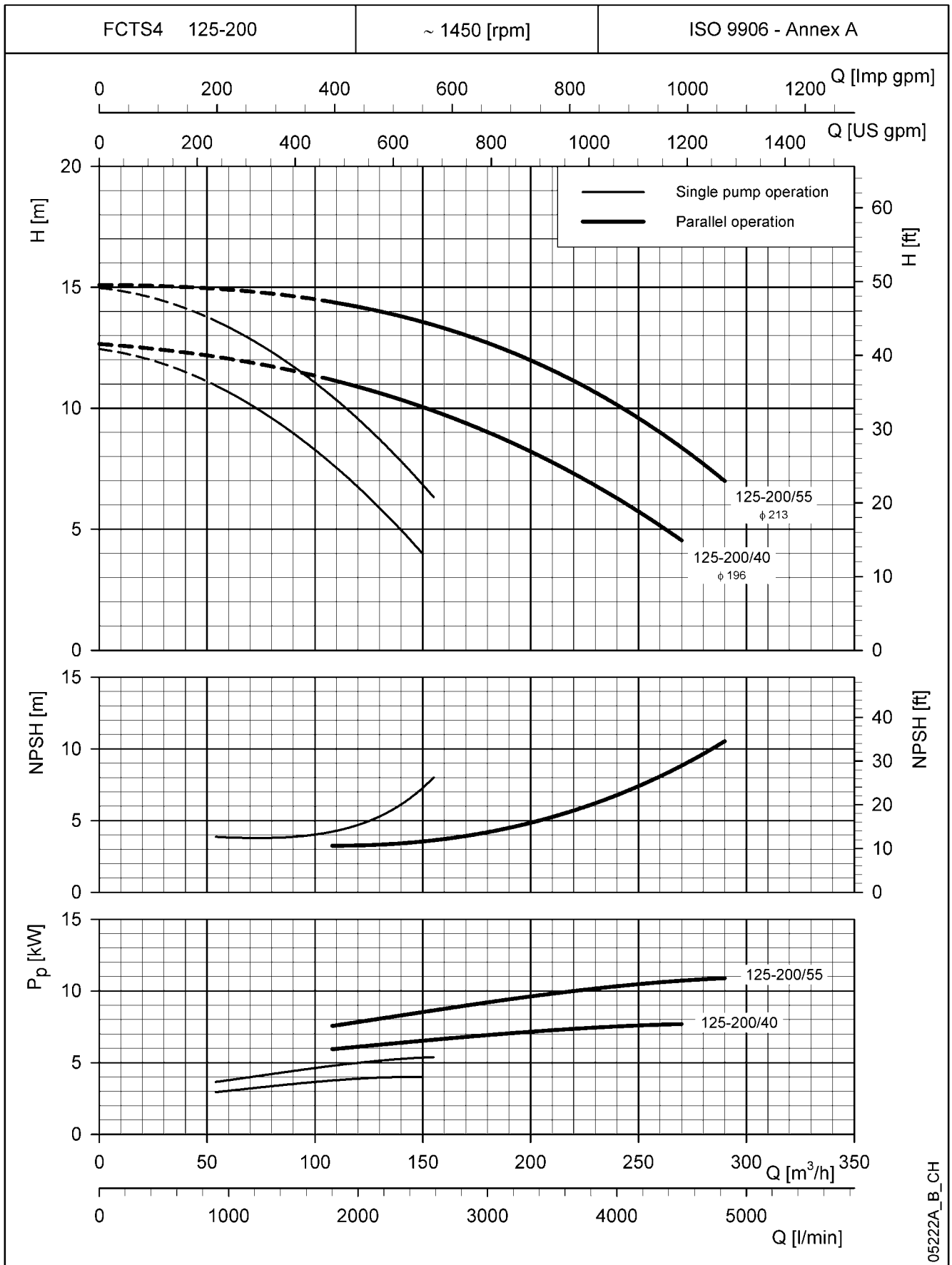

05222A_B_CH

The NPSH values are laboratory values; for practical use we suggest increasing these values by 0,5 m.
These performances are valid for liquids with density $\rho = 1,0 \text{ Kg/dm}^3$ and kinematic viscosity $\nu = 1 \text{ mm}^2/\text{sec}$.

**FCTS4 SERIES
OPERATING CHARACTERISTICS AT 50 Hz, 4 POLES**

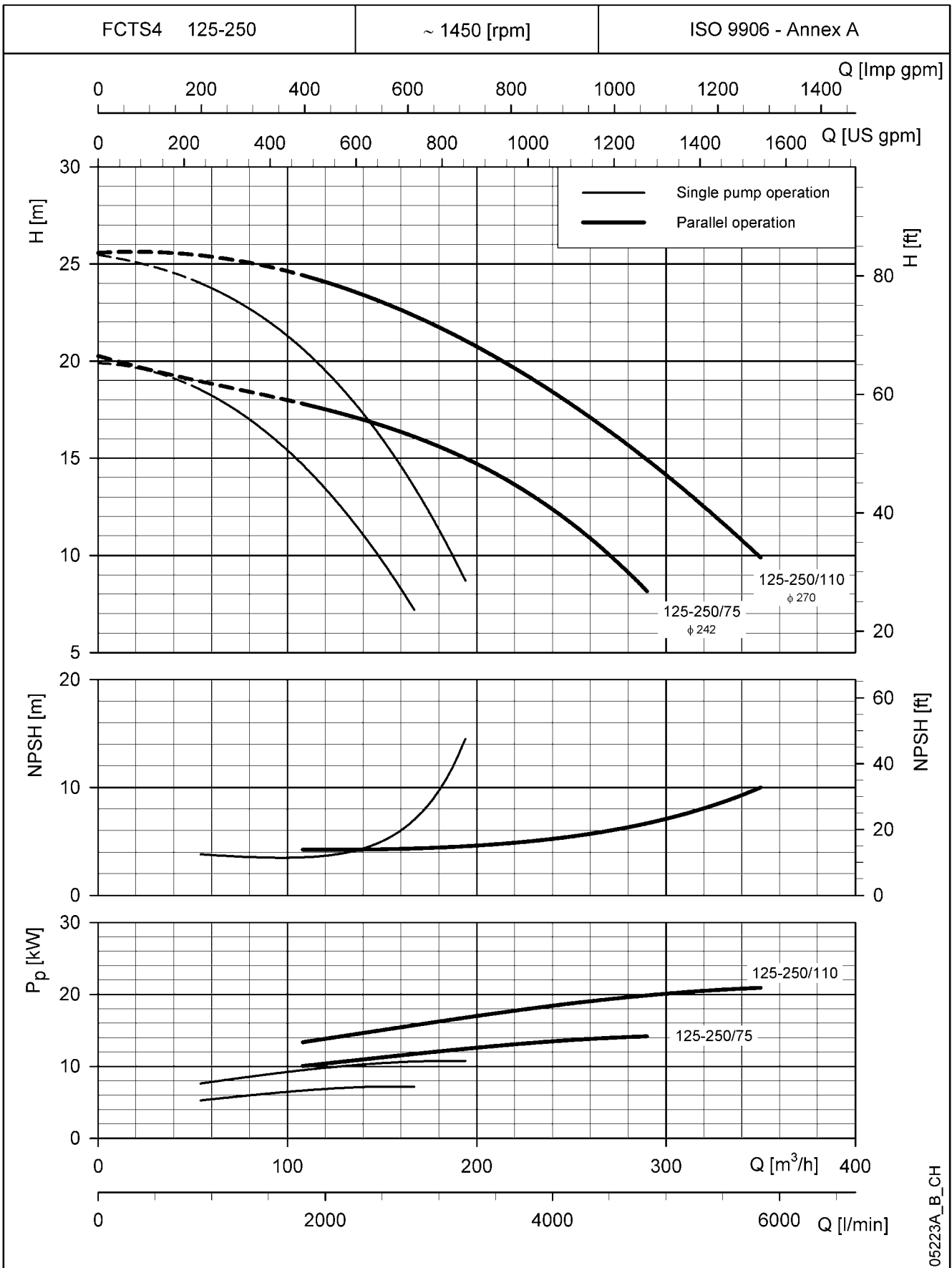

05223A_B_CH

The NPSH values are laboratory values; for practical use we suggest increasing these values by 0,5 m.
These performances are valid for liquids with density $\rho = 1,0 \text{ Kg/dm}^3$ and kinematic viscosity $\nu = 1 \text{ mm}^2/\text{sec}$.

**FCTS4 SERIES
OPERATING CHARACTERISTICS AT 50 Hz, 4 POLES**

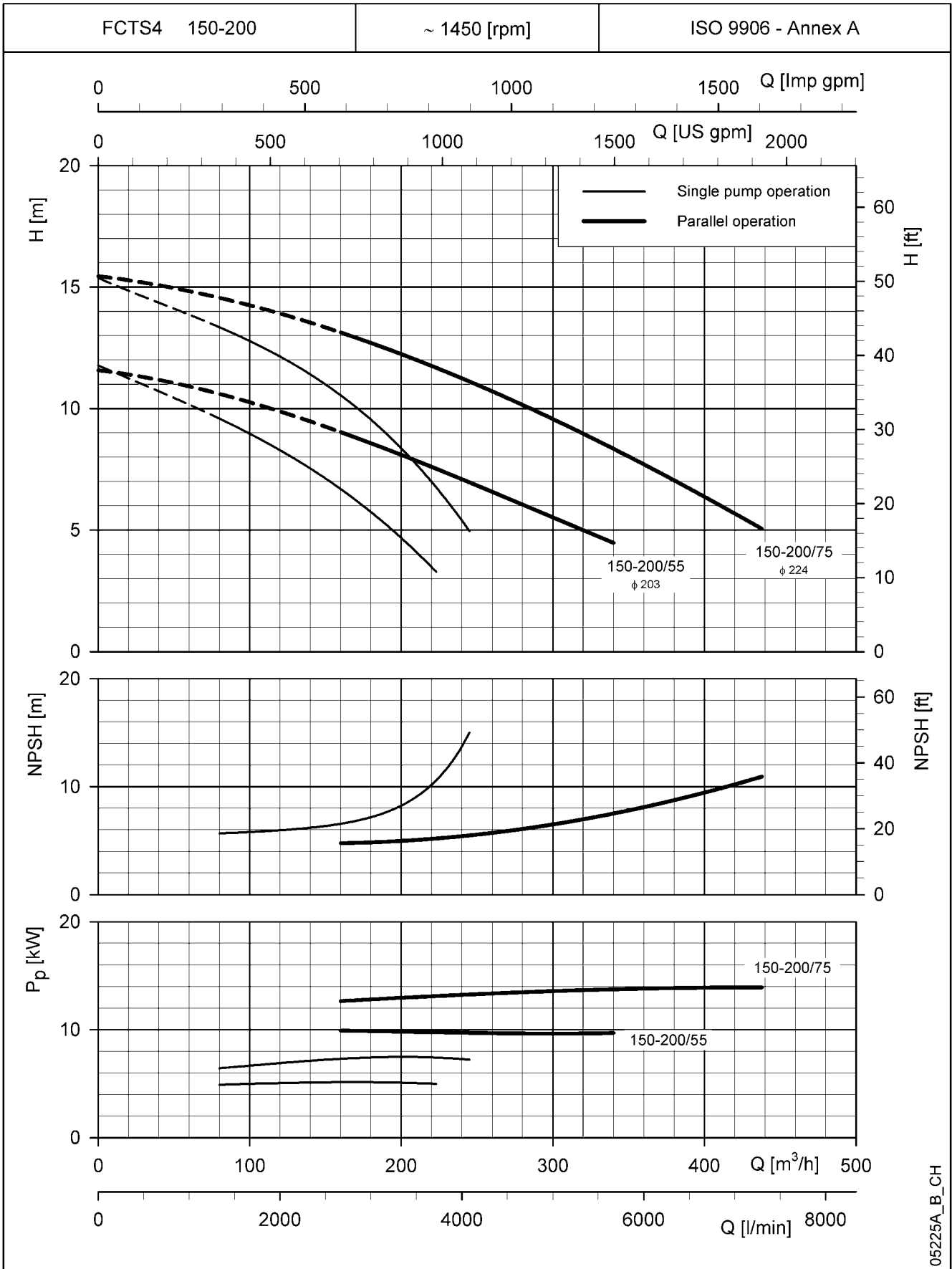

05225A_B_CH

The NPSH values are laboratory values; for practical use we suggest increasing these values by 0,5 m.
These performances are valid for liquids with density $\rho = 1,0 \text{ Kg/dm}^3$ and kinematic viscosity $\nu = 1 \text{ mm}^2/\text{sec}$.

**FCTS4 SERIES
OPERATING CHARACTERISTICS AT 50 Hz, 4 POLES**

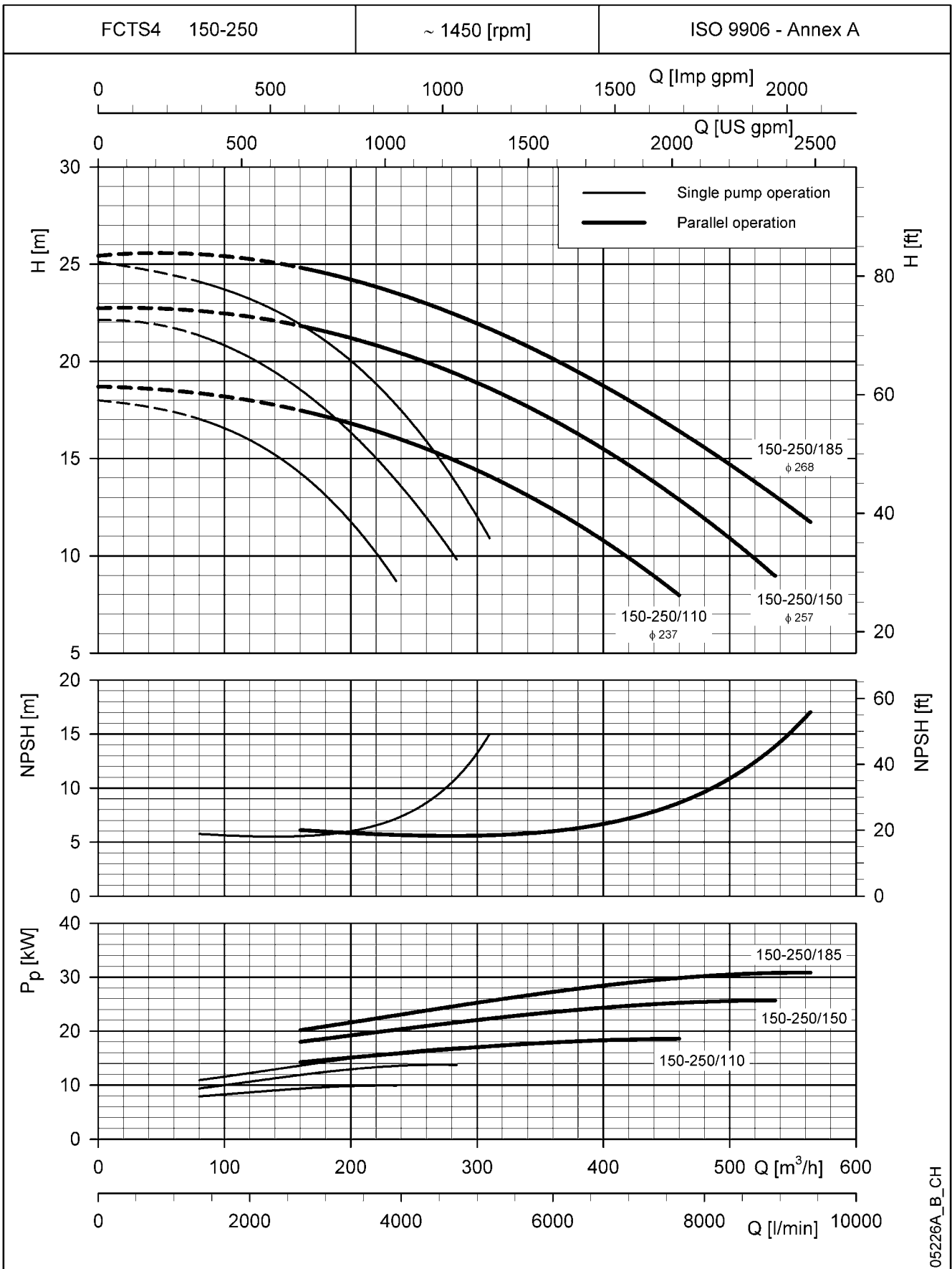

05226A_B_CH

The NPSH values are laboratory values; for practical use we suggest increasing these values by 0,5 m.
These performances are valid for liquids with density $\rho = 1,0 \text{ Kg/dm}^3$ and kinematic viscosity $\nu = 1 \text{ mm}^2/\text{sec}$.

DIMENSIONS AND WEIGHTS

FCE SERIES DIMENSIONS AND WEIGHTS AT 50 Hz

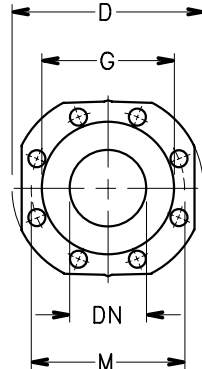
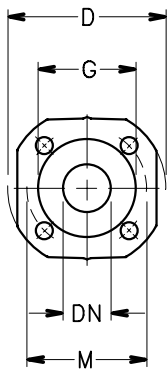
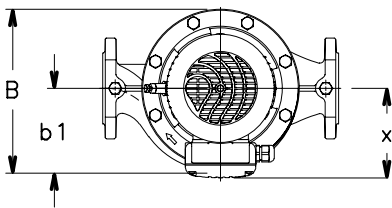
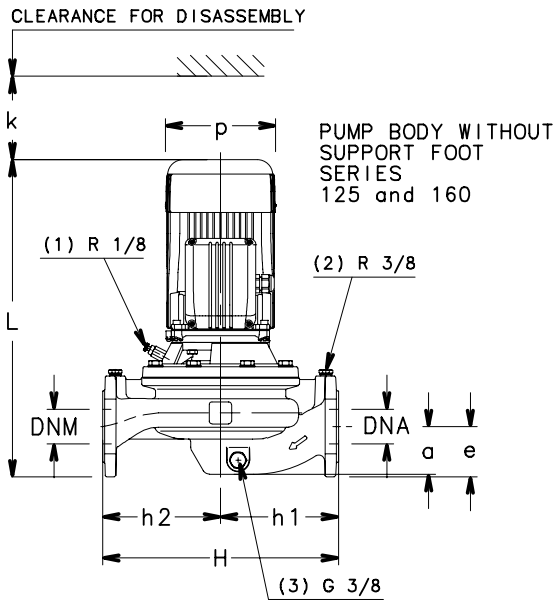

PUMP FLANGES

DN	D	M	G	HOLES		THICKNESS MAX.
				N°	DIA.	
40	150	110	88	4	18	18
50	165	125	102	4	18	20
65	185	145	122	4	18	20
80	200	160	138	8	18	22
100	220	180	158	8	18	22

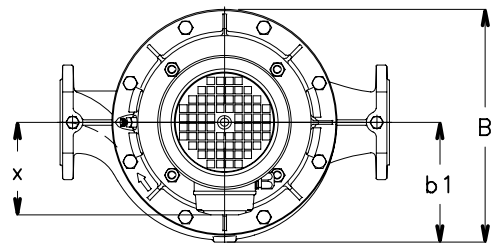
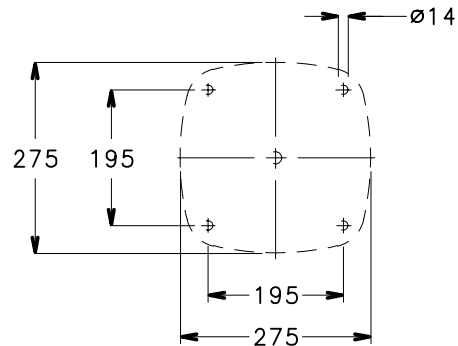
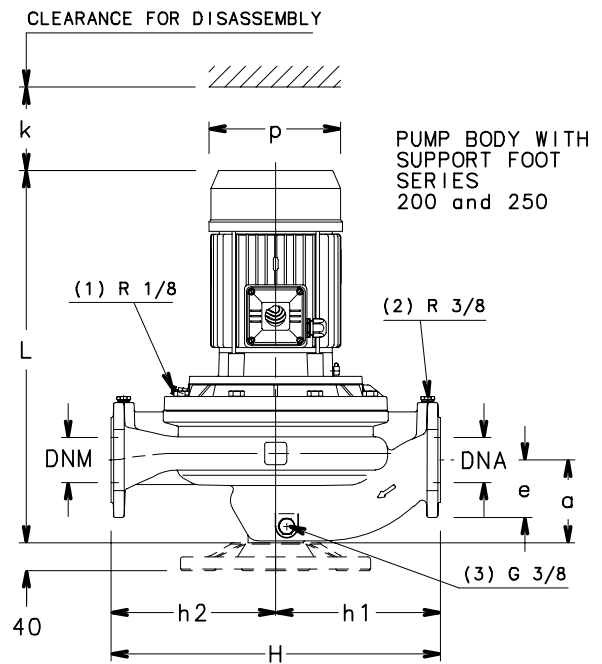

- (1) R 1/8 AIR VALVE
- (2) R 3/8 PRESSURE GAUGE CONNECTOR
- (3) G 3/8 DRAIN

04804D-EN_B_DD

FCE SERIES

DIMENSIONS AND WEIGHTS AT 50 Hz

PUMP TYPE	DIMENSIONS (mm)													WEIGHT kg
	DNA	DNM	a	e	h1	h2	x	b1	p	B	H max	L	k	
FCE 40-125/07/D	40	40	70	70	160	160	129	116	155	243	320	448	86	29
FCE 40-125/11/D	40	40	70	70	160	160	129	116	155	243	320	448	86	30
FCE 40-160/15/D	40	40	70	70	160	160	129	116	155	243	320	448	86	31
FCE 40-160/22/C	40	40	70	70	160	160	134	116	174	248	320	483	86	35
FCE 40-200/40A/P	40	40	95	65	220	220	154	163	197	325	440	514	98	72
FCE 40-200/40/P	40	40	95	65	220	220	154	163	197	325	440	514	98	72
FCE 40-200/55/P	40	40	95	65	220	220	168	163	214	330	440	548	98	73
FCE 40-250/75/P	40	40	95	65	220	220	191	163	256	353	440	562	98	91
FCE 40-250/110/P	40	40	95	65	220	220	191	163	256	353	440	600	98	92
FCE 50-125/11/D	50	50	69	73	170	170	129	122	155	243	340	457	88	32
FCE 50-125/15/D	50	50	69	73	170	170	129	122	155	243	340	457	88	34
FCE 50-160/22/C	50	50	69	73	170	170	134	122	174	248	340	492	88	44
FCE 50-160/30/P	50	50	69	73	170	170	134	122	174	248	340	492	88	46
FCE 50-160/40/P	50	50	69	73	170	170	154	122	197	268	340	513	88	49
FCE 50-200/55/P	50	50	110	73	220	220	168	163	214	331	440	577	100	56
FCE 50-200/75/P	50	50	110	73	220	220	191	163	256	354	440	591	100	72
FCE 50-250/92/P	50	50	110	73	220	220	191	163	256	354	440	629	100	101
FCE 50-250/110/P	50	50	110	73	220	220	191	163	256	354	440	629	100	107
FCE 50-250/150/P	50	50	110	73	220	220	240	163	313	403	440	718	100	115
FCE 65-125/22/C	65	65	77	83	170	170	134	137	174	274	340	511	92	54
FCE 65-125/30/P	65	65	77	83	170	170	134	137	174	274	340	511	92	57
FCE 65-125/40/P	65	65	77	83	170	170	154	137	197	291	340	532	92	61
FCE 65-160/55/P	65	65	77	83	170	170	168	137	214	305	340	566	92	69
FCE 65-160/75/P	65	65	77	83	170	170	191	137	256	328	340	580	92	86
FCE 65-200/92/P	65	65	119	83	237,5	237,5	191	172	256	354	475	634	104	105
FCE 65-200/110/P	65	65	119	83	237,5	237,5	191	172	256	354	475	634	104	112
FCE 65-250/150/P	65	65	119	83	237,5	237,5	240	172	313	403	475	723	104	128
FCE 65-250/185/P	65	65	119	83	237,5	237,5	240	172	313	403	475	723	104	138
FCE 65-250/220/P	65	65	119	83	237,5	237,5	240	172	313	403	475	723	104	150
FCE 80-125/30/P	80	80	90	90	175	185	134	148	174	287	360	545	102	64
FCE 80-125/40/P	80	80	90	90	175	185	154	148	197	293	360	566	102	67
FCE 80-125/55/P	80	80	90	90	175	185	168	148	214	307	360	600	102	69
FCE 80-160/75/P	80	80	90	90	175	185	191	148	256	330	360	614	102	85
FCE 80-200/110/P	80	80	130	90	250	250	191	184	256	354	500	661	112	120
FCE 80-200/150/P	80	80	130	90	250	250	240	184	313	403	500	750	112	130
FCE 80-200/185/P	80	80	130	90	250	250	240	184	313	403	500	750	112	140
FCE 80-200/220/P	80	80	130	90	250	250	240	184	313	403	500	750	112	152
FCE 100-160/110/P	100	100	105	105	225	225	191	172	256	330	450	677	117	127
FCE 100-200/185/P	100	100	140	105	275	275	240	196	313	406	550	771	129	180
FCE 100-200/220/P	100	100	140	105	275	275	240	196	313	406	550	771	129	192

fc_fce-2p50-en_g_td

FCE4 SERIES DIMENSIONS AND WEIGHTS AT 50 Hz

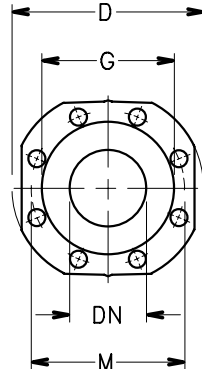
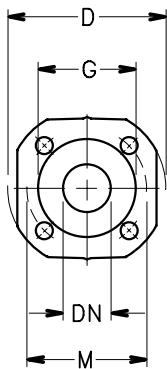
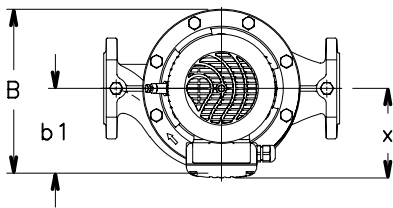
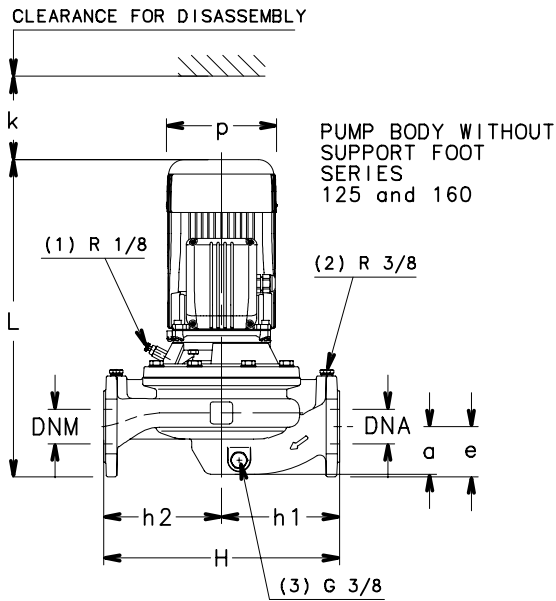

PUMP FLANGES

DN	D	M	G	HOLES		THICKNESS MAX.
				N°	DIA.	
40	150	110	88	4	18	18
50	165	125	102	4	18	20
65	185	145	122	4	18	20
80	200	160	138	8	18	22
100	220	180	158	8	18	22

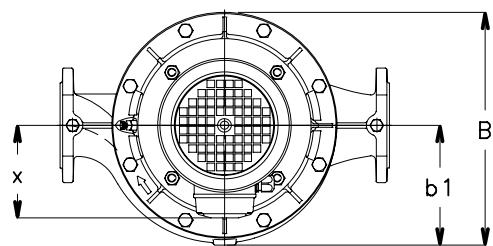
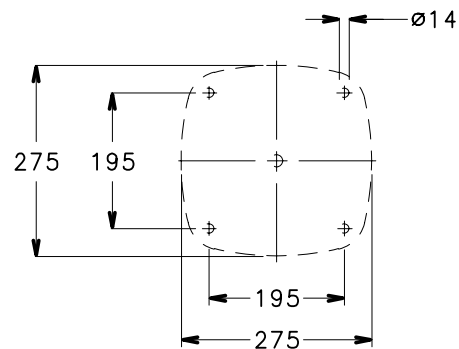
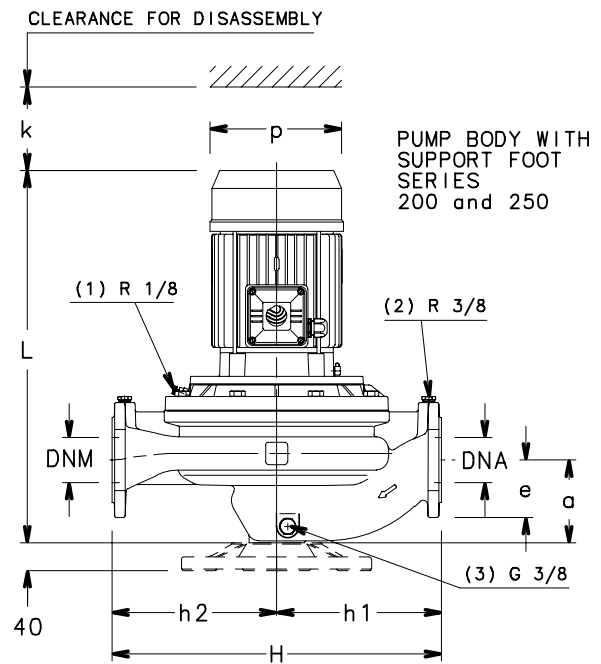

- (1) R 1/8 AIR VALVE
- (2) R 3/8 PRESSURE GAUGE CONNECTOR
- (3) G 3/8 DRAIN

FCE4 SERIES

DIMENSIONS AND WEIGHTS AT 50 Hz

PUMP TYPE	DIMENSIONS (mm)													WEIGHT kg
	DNA	DNM	a	e	h1	h2	x	b1	p	B	H max	L	k	
FCE4 40-125/02A/A	40	40	70	70	160	160	121	116	140	235	320	416	86	24
FCE4 40-125/02/A	40	40	70	70	160	160	121	116	140	235	320	416	86	24
FCE4 40-160/02/A	40	40	70	70	160	160	121	116	140	235	320	416	86	25
FCE4 40-160/03/A	40	40	70	70	160	160	121	116	140	235	320	416	86	26
FCE4 40-200/05/A	40	40	95	65	220	220	129	163	155	325	440	458	98	44
FCE4 40-200/07/C	40	40	95	65	220	220	128	163	159	325	440	426	98	45
FCE4 40-250/11/P	40	40	95	65	220	220	134	163	174	325	440	493	98	64
FCE4 40-250/15/P	40	40	95	65	220	220	134	163	174	325	440	493	98	65
FCE4 50-125/02/A	50	50	69	73	170	170	121	122	140	236	340	425	88	28
FCE4 50-125/03/A	50	50	69	73	170	170	121	122	140	236	340	425	88	29
FCE4 50-160/05/A	50	50	69	73	170	170	129	122	155	243	340	457	88	31
FCE4 50-200/07/C	50	50	110	73	220	220	128	163	159	326	440	455	100	54
FCE4 50-200/11/P	50	50	110	73	220	220	134	163	174	326	440	522	100	63
FCE4 50-250/15/P	50	50	110	73	220	220	134	163	174	326	440	522	100	66
FCE4 50-250/22/P	50	50	110	73	220	220	168	163	214	331	440	546	100	72
FCE4 65-125/03/A	65	65	77	83	170	170	121	137	140	274	340	444	92	38
FCE4 65-125/05/A	65	65	77	83	170	170	129	137	155	274	340	476	92	42
FCE4 65-160/07/C	65	65	77	83	170	170	128	137	159	274	340	444	92	47
FCE4 65-160/11/P	65	65	77	83	170	170	134	137	174	274	340	511	92	54
FCE4 65-200/15/P	65	65	119	83	237,5	237,5	134	172	174	335	475	527	104	69
FCE4 65-250/22/P	65	65	119	83	237,5	237,5	168	172	214	335	475	551	104	80
FCE4 65-250/30/P	65	65	119	83	237,5	237,5	168	172	214	335	475	582	104	82
FCE4 80-125/07/C	80	80	90	90	175	185	128	148	159	287	360	478	102	51
FCE4 80-125/11/P	80	80	90	90	175	185	134	148	174	287	360	545	102	59
FCE4 80-200/15/P	80	80	130	90	250	250	134	184	174	347	500	554	112	81
FCE4 80-200/22/P	80	80	130	90	250	250	168	184	214	347	500	578	112	87
FCE4 80-200/30/P	80	80	130	90	250	250	168	184	214	347	500	609	112	91
FCE4 80-250/40/P	80	80	130	90	250	250	168	184	214	347	500	654	112	117
FCE4 80-250/55/P	80	80	130	90	250	250	191	184	256	354	500	661	112	125
FCE4 100-160/15/P	100	100	105	105	225	225	134	172	174	311	450	570	117	74
FCE4 100-200/22/P	100	100	140	105	275	275	168	196	214	362	550	599	129	99
FCE4 100-200/30/P	100	100	140	105	225	275	168	196	214	362	550	630	129	101
FCE4 100-250/40/P	100	100	140	105	275	275	168	196	214	362	550	675	129	125
FCE4 100-250/55/P	100	100	140	105	275	275	191	196	256	362	550	682	129	131
FCE4 100-250/75/P	100	100	140	105	275	275	191	196	256	362	550	682	129	141

fc_fce4-4p50-en_g_td

FCS SERIES DIMENSIONS AND WEIGHTS AT 50 Hz

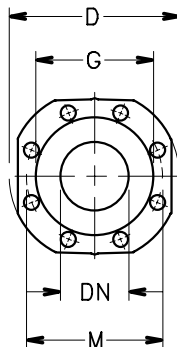
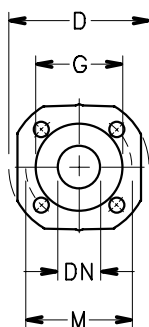
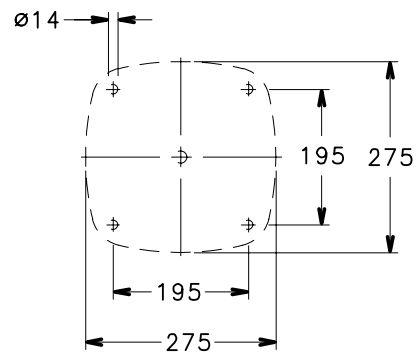
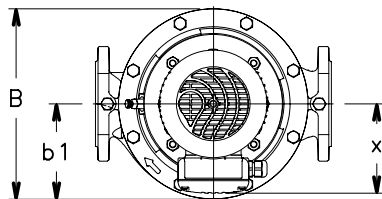
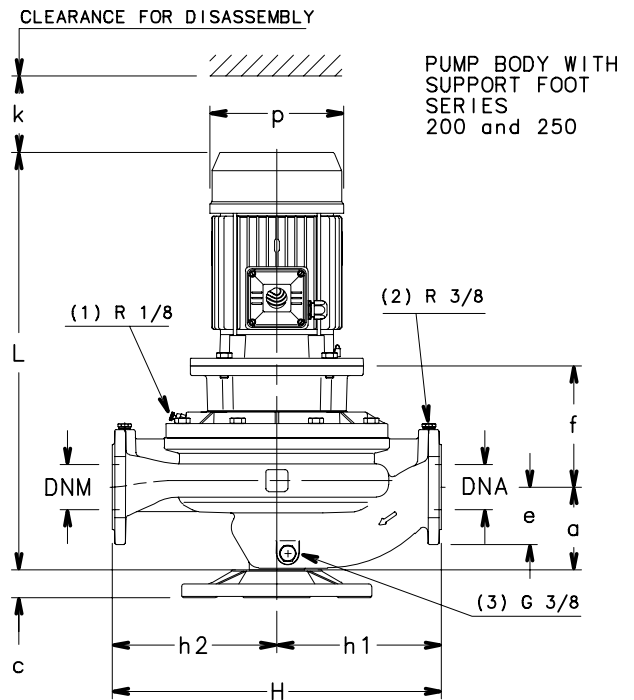
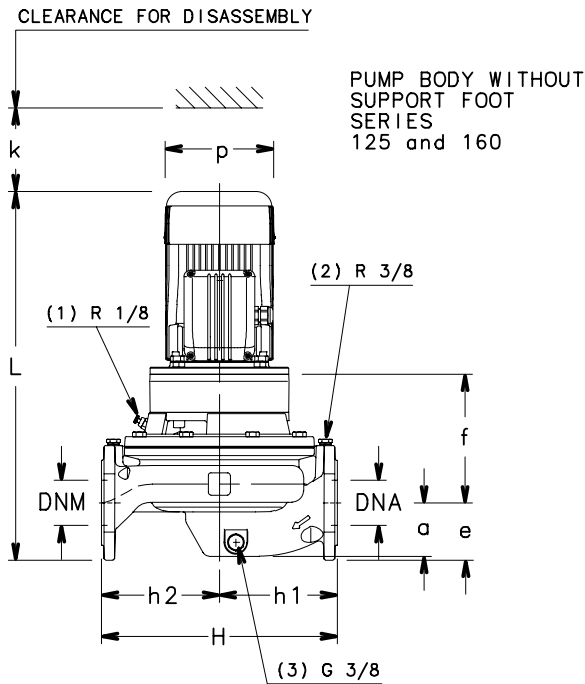

PUMP FLANGES

DN	D	M	G	HOLES		THICKNESS MAX.
				N°	DIA.	
40	150	110	88	4	18	18
50	165	125	102	4	18	20
65	185	145	122	4	18	20
80	200	160	138	8	18	22
100	220	180	158	8	18	22

- (1) R 1/8 AIR VALVE
- (2) R 3/8 PRESSURE GAUGE CONNECTOR
- (3) G 3/8 DRAIN

FCS SERIES

DIMENSIONS AND WEIGHTS AT 50 Hz

PUMP TYPE	DIMENSIONS (mm)														WEIGHT kg
	DNA	DNM	a	e	f	h1	h2	x	b1	p	B	H max	L	k	
FCS 40-125/07/D	40	40	70	70	170	160	160	129	116	155	243	320	503	86	32
FCS 40-125/11/D	40	40	70	70	170	160	160	129	116	155	243	320	503	86	33
FCS 40-160/15/D	40	40	70	70	170	160	160	129	116	155	243	320	503	86	34
FCS 40-160/22/C	40	40	70	70	170	160	160	134	116	174	248	320	538	86	39
FCS 40-200/30/P	40	40	95	65	165	220	220	134	163	174	325	440	558	98	69
FCS 40-200/40/P	40	40	95	65	165	220	220	154	163	197	325	440	579	98	75
FCS 40-200/55/P	40	40	95	65	192	220	220	168	163	214	330	440	662	98	88
FCS 40-250/75/P	40	40	95	65	192	220	220	191	163	256	353	440	654	98	106
FCS 40-250/110/P	40	40	95	65	222	220	220	191	163	256	353	440	745	98	120
FCS 50-125/11/D	50	50	69	73	176	170	170	129	122	155	243	340	512	88	37
FCS 50-125/15/D	50	50	69	73	176	170	170	129	122	155	243	340	512	88	38
FCS 50-160/22/C	50	50	69	73	176	170	170	134	122	174	248	340	547	88	50
FCS 50-160/30/P	50	50	69	73	186	170	170	134	122	174	248	340	557	88	51
FCS 50-160/40/P	50	50	69	73	186	170	170	154	122	197	268	340	578	88	58
FCS 50-200/55/P	50	50	110	73	206	220	220	168	163	214	331	440	691	100	91
FCS 50-200/75/P	50	50	110	73	206	220	220	191	163	256	354	440	683	100	108
FCS 50-250/110A/P	50	50	110	73	236	220	220	191	163	256	354	440	774	100	115
FCS 50-250/110/P	50	50	110	73	236	220	220	191	163	256	354	440	774	100	115
FCS 50-250/150/P	50	50	110	73	236	220	220	240	163	313	403	440	840	100	125
FCS 65-125/22/C	65	65	77	83	185	170	170	134	137	174	274	340	566	92	69
FCS 65-125/30/P	65	65	77	83	195	170	170	134	137	174	274	340	576	92	62
FCS 65-125/40/P	65	65	77	83	195	170	170	154	137	197	291	340	597	92	67
FCS 65-160/55/P	65	65	77	83	222	170	170	168	137	214	305	340	680	92	80
FCS 65-160/75/P	65	65	77	83	222	170	170	191	137	256	328	340	672	92	95
FCS 65-200/110A/P	65	65	119	83	232	237,5	237,5	191	172	256	354	475	779	104	133
FCS 65-200/110/P	65	65	119	83	232	237,5	237,5	191	172	256	354	475	779	104	133
FCS 65-250/150/P	65	65	119	83	232	237,5	237,5	240	172	313	403	475	845	104	134
FCS 65-250/185/P	65	65	119	83	232	237,5	237,5	240	172	313	403	475	845	104	144
FCS 65-250/220/P	65	65	119	83	232	237,5	237,5	240	172	313	403	475	845	104	154
FCS 80-125/30/P	80	80	90	90	222	175	185	134	148	174	287	360	610	102	82
FCS 80-125/40/P	80	80	90	90	222	175	185	154	148	197	293	360	631	102	83
FCS 80-125/55/P	80	80	90	90	249	175	185	168	148	214	307	360	714	102	86
FCS 80-160/75/P	80	80	90	90	249	175	185	191	148	256	330	360	706	102	102
FCS 80-200/110/P	80	80	130	90	248	250	250	191	184	256	354	500	806	112	130
FCS 80-200/150/P	80	80	130	90	248	250	250	240	184	313	403	500	872	112	140
FCS 80-200/185/P	80	80	130	90	248	250	250	240	184	313	403	500	872	112	150
FCS 80-200/220/P	80	80	130	90	248	250	250	240	184	313	403	500	872	112	162
FCS 100-160/110/P	100	100	105	105	289	225	225	191	172	256	330	450	822	117	135
FCS 100-200/185/P	100	100	140	105	259	275	275	240	196	313	406	550	893	129	190
FCS 100-200/220/P	100	100	140	105	259	275	275	240	196	313	406	550	893	129	202

fc_fcs-2p50-en_g_td

FCS4 SERIES DIMENSIONS AND WEIGHTS AT 50 Hz

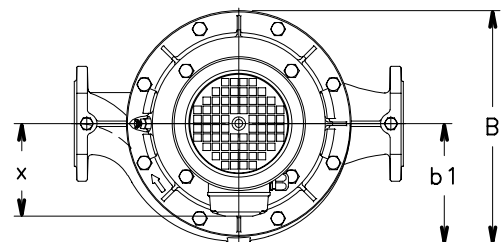
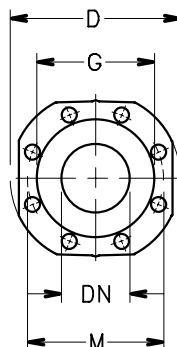
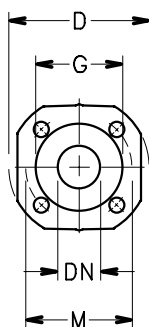
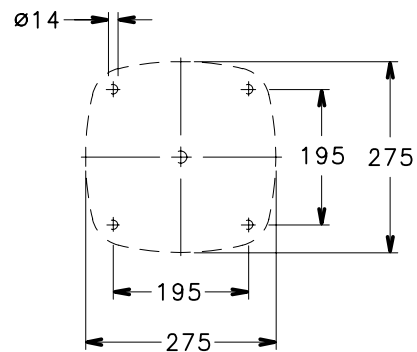
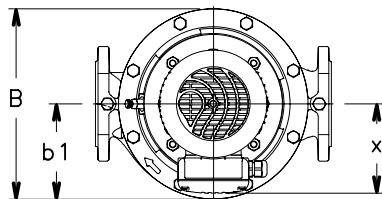
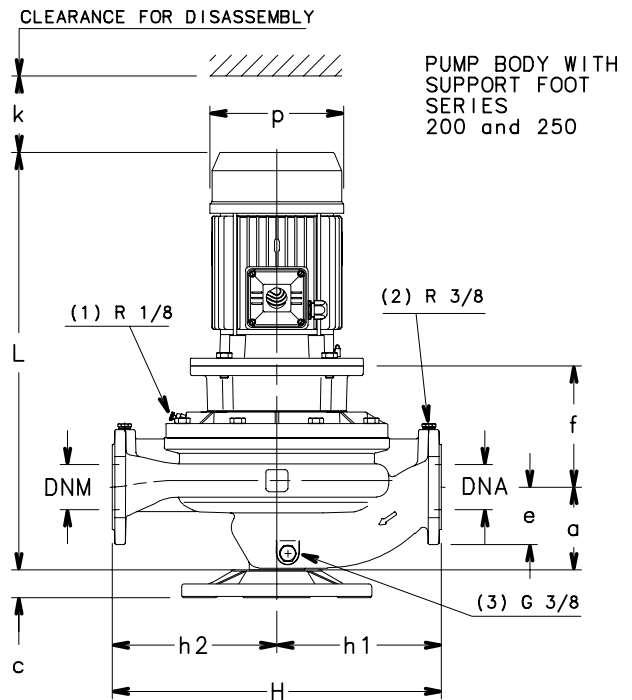
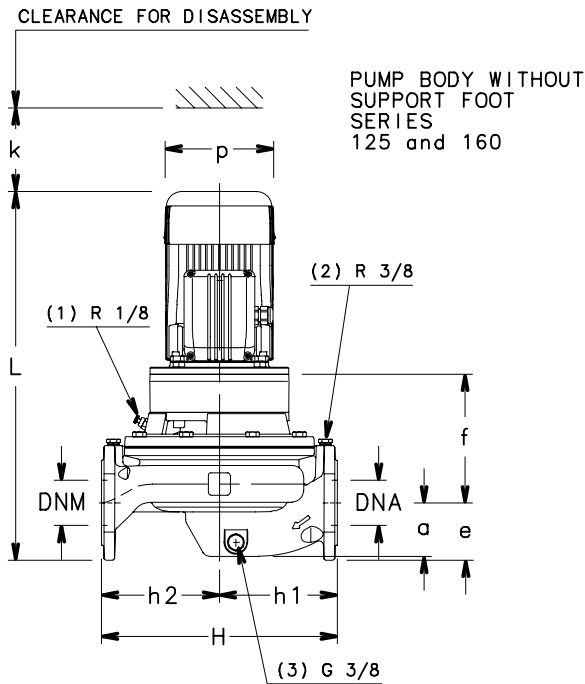

PUMP FLANGES

DN	D	M	G	HOLES		THICKNESS MAX.
				N°	DIA.	
40	150	110	88	4	18	18
50	165	125	102	4	18	20
65	185	145	122	4	18	20
80	200	160	138	8	18	22
100	220	180	158	8	18	22

- (1) R 1/8 AIR VALVE
- (2) R 3/8 PRESSURE GAUGE CONNECTOR
- (3) G 3/8 DRAIN

FCS4 SERIES

DIMENSIONS AND WEIGHTS AT 50 Hz

PUMP TYPE	DIMENSIONS (mm)														WEIGHT kg
	DNA	DNM	a	e	f	h1	h2	x	b1	p	B	H max	L	k	
FCS4 40-200/05/A	40	40	95	65	155	220	220	129	163	155	325	440	513	98	56
FCS4 40-200/07/C	40	40	95	65	155	220	220	128	163	159	325	440	481	98	60
FCS4 40-250/11/P	40	40	95	65	155	220	220	134	163	174	325	440	548	98	67
FCS4 40-250/15/P	40	40	95	65	155	220	220	134	163	174	325	440	548	98	69
FCS4 50-200/07/C	50	50	110	73	169	220	220	128	163	159	326	440	510	100	63
FCS4 50-200/11/P	50	50	110	73	169	220	220	134	163	174	326	440	577	100	72
FCS4 50-250/15/P	50	50	110	73	169	220	220	134	163	174	326	440	577	100	73
FCS4 50-250/22/P	50	50	110	73	179	220	220	168	163	214	331	440	611	100	78
FCS4 65-160/07/C	65	65	77	83	185	170	170	128	137	159	274	340	499	92	49
FCS4 65-160/11/P	65	65	77	83	185	170	170	134	137	174	274	340	566	92	55
FCS4 65-200/15/P	65	65	119	83	165	237,5	237,5	134	172	174	335	475	582	104	72
FCS4 65-250/22/P	65	65	119	83	175	237,5	237,5	168	172	214	335	475	616	104	84
FCS4 65-250/30/P	65	65	119	83	175	237,5	237,5	168	172	214	335	475	647	104	87
FCS4 80-125/07/C	80	80	90	90	212	175	185	128	148	159	287	360	533	102	55
FCS4 80-125/11/P	80	80	90	90	212	175	185	134	148	174	287	360	600	102	66
FCS4 80-200/15/P	80	80	130	90	181	250	250	134	184	174	347	500	609	112	92
FCS4 80-200/22/P	80	80	130	90	191	250	250	168	184	214	347	500	643	112	95
FCS4 80-200/30/P	80	80	130	90	191	250	250	168	184	214	347	500	674	112	97
FCS4 80-250/40/P	80	80	130	90	191	250	250	168	184	214	347	500	719	112	125
FCS4 80-250/55/P	80	80	130	90	218	250	250	191	184	256	354	500	753	112	129
FCS4 100-160/15/P	100	100	105	105	221	225	225	134	172	174	311	450	625	117	78
FCS4 100-200/22/P	100	100	140	105	202	275	275	168	196	214	362	550	664	129	85
FCS4 100-200/30/P	100	100	140	105	202	225	275	168	196	214	362	550	695	129	88
FCS4 100-250/40/P	100	100	140	105	202	275	275	168	196	214	362	550	740	129	140
FCS4 100-250/55/P	100	100	140	105	229	275	275	191	196	256	362	550	774	129	142
FCS4 100-250/75/P	100	100	140	105	229	275	275	191	196	256	362	550	774	129	147

fc_fcs4-4p50-en_g_td

**FCS4 (125÷150) SERIES
DIMENSIONS AND WEIGHTS AT 50 Hz**

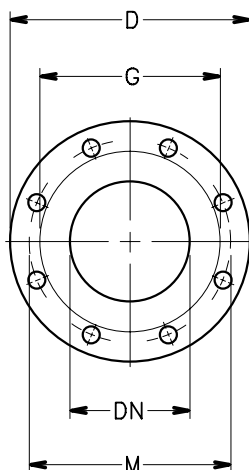
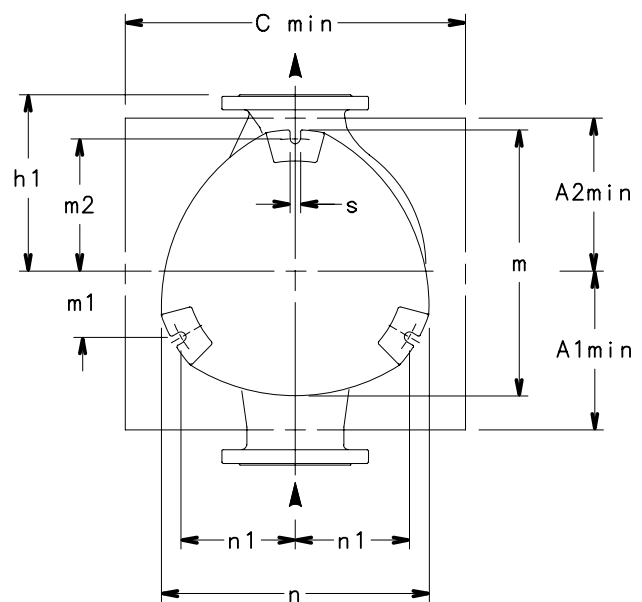
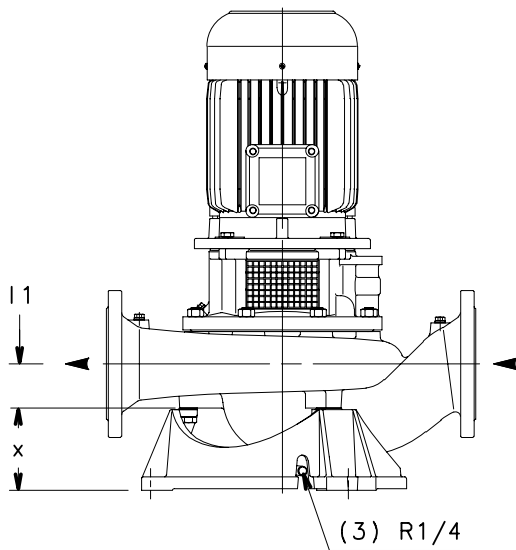
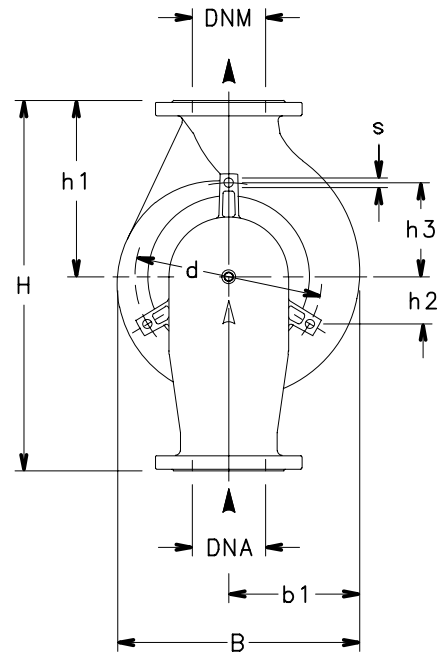
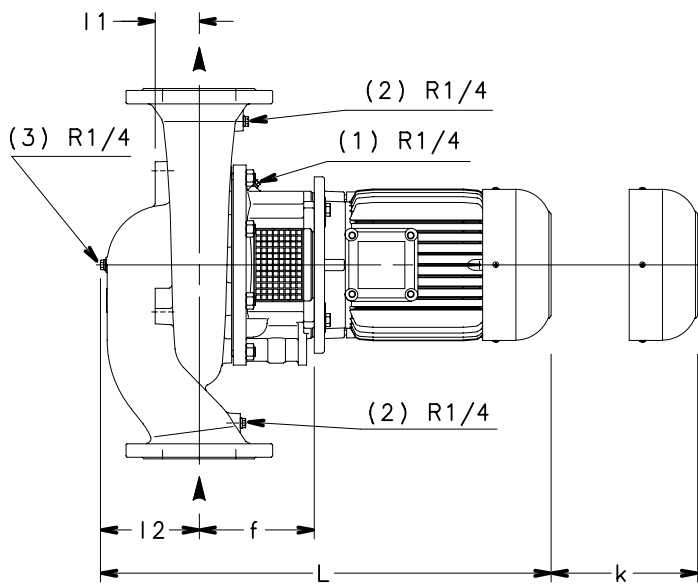

- (1) R 1/4 AIR VALVE
- (2) R 1/4 PRESSURE GAUGE CONNECTOR
- (3) R 1/4 DRAIN

PUMP FLANGES

DN	D	M	G	HOLES		THICKNESS
				N°	DIA.	MAX.
125	250	210	188	8	18	26
150	285	240	212	8	23	26

04852D-EN_A_DD

FCS4 (125÷150) SERIES

DIMENSIONS AND WEIGHTS AT 50 Hz

PUMP TYPE	DIMENSIONS (mm) PUMP														WEIGHT kg
	DNA	DNM	b1	d	f	h1	h2	h3	l1	l2	B	H max	L	k	
FCS4 125-160/30/P	125	125	234	274	196	315	68	137	85	161	418	630	710	143	132
FCS4 125-200/40/P	125	125	202	274	196	290	68	137	80	164	378	620	758	153	133
FCS4 125-200/55/P	125	125	202	274	196	290	68	137	80	164	378	620	765	153	154
FCS4 125-250/75/P	125	125	220	320	196	300	80	160	75	168	422	630	769	150	167
FCS4 125-250/110/P	125	125	220	320	226	300	80	160	75	168	422	630	888	150	231
FCS4 125-315/150/P	125	125	262	320	226	350	80	160	130	229	503	775	948	160	298
FCS4 125-315/185/C	125	125	262	320	226	350	80	160	130	229	503	775	1009	160	334
FCS4 125-315/220/C	125	125	262	320	226	350	80	160	130	229	503	775	1047	160	356
FCS4 150-200/55/P	150	150	260	320	211	340	80	160	90	178	468	720	794	160	126
FCS4 150-200/75/P	150	150	260	320	211	340	80	160	90	178	468	720	794	160	177
FCS4 150-250/110/P	150	150	276	320	226	365	80	160	85	188	504	755	908	158	255
FCS4 150-250/150/P	150	150	276	320	226	365	80	160	85	188	504	755	908	158	268
FCS4 150-250/185/C	150	150	276	320	226	365	80	160	85	188	504	755	968	158	294

PUMP TYPE	DIMENSIONS (mm) SUPPORT FOOT										
	A1	A2	C	m	m1	m2	n	n1	s	x	
FCS4 125-160/30/P	230	250	480	388	96	192	389	166	M16	120	
FCS4 125-200/40/P	230	250	480	388	96	192	389	166	M16	120	
FCS4 125-200/55/P	230	250	480	388	96	192	389	166	M16	120	
FCS4 125-250/75/P	270	300	580	453	112	225	457	195	M16	140	
FCS4 125-250/110/P	270	300	580	453	112	225	457	195	M16	140	
FCS4 125-315/150/P	270	300	580	453	112	225	457	195	M16	140	
FCS4 125-315/185/C	270	300	580	453	112	225	457	195	M16	140	
FCS4 125-315/220/C	270	300	580	453	112	225	457	195	M16	140	
FCS4 150-200/55/P	270	300	580	453	112	225	457	195	M16	140	
FCS4 150-200/75/P	270	300	580	453	112	225	457	195	M16	140	
FCS4 150-250/110/P	270	300	580	453	112	225	457	195	M16	140	
FCS4 150-250/150/P	270	300	580	453	112	225	457	195	M16	140	
FCS4 150-250/185/C	270	300	580	453	112	225	457	195	M16	140	

lmr_fcs4-4p50-en_e_td

FCTE SERIES DIMENSIONS AND WEIGHTS AT 50 Hz

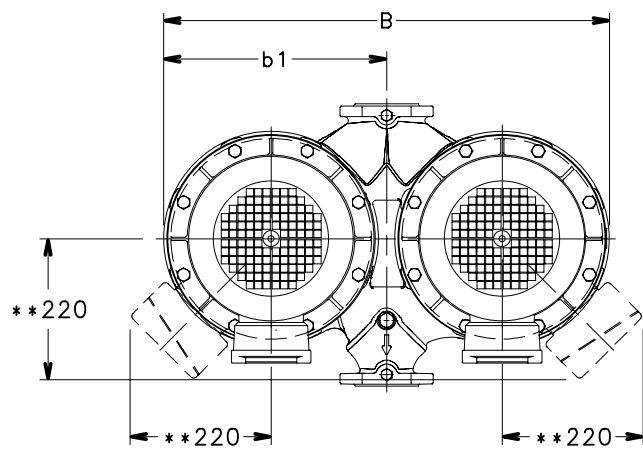
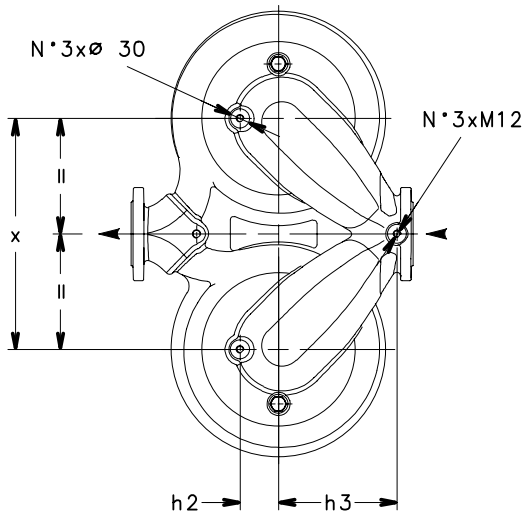
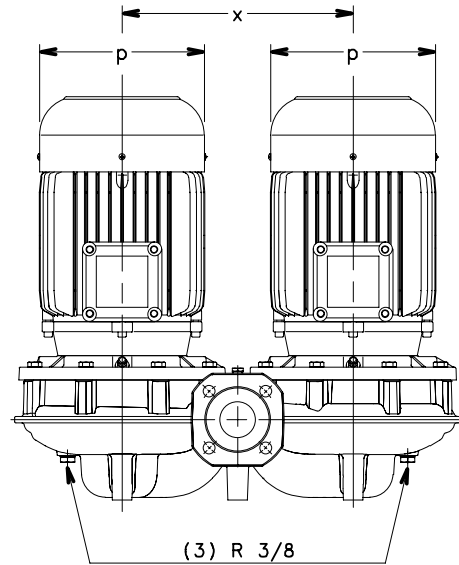
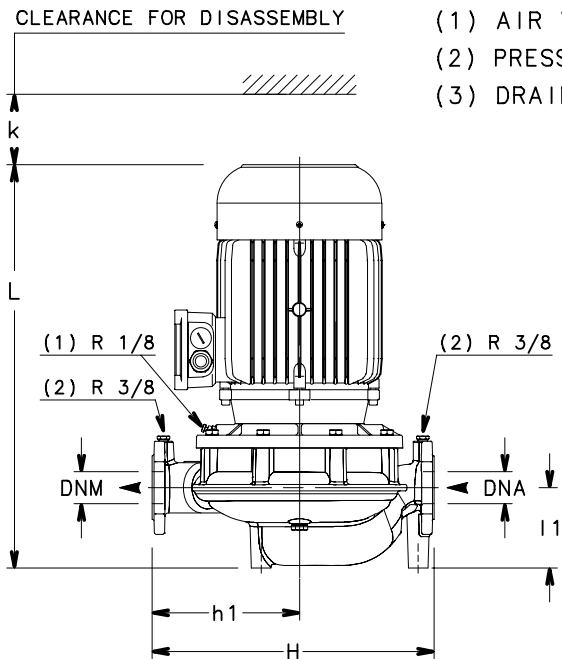

** ONLY FOR MODELS WITH
15-18.5-22 kW MOTORS

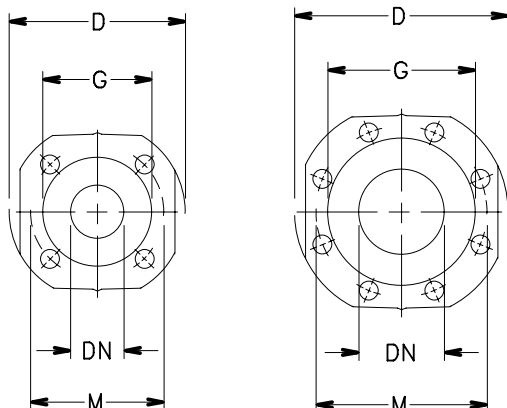

PUMP FLANGES

DN	D	M	G	HOLES		MAX. THICKNESS
				N°	DIA.	
40	150	110	88	4	18	18
50	165	125	102	4	18	20
65	185	145	122	4	18	20
80	200	160	138	8	18	22
100	220	180	158	8	18	22

FCTE SERIES

DIMENSIONS AND WEIGHTS AT 50 Hz

PUMP TYPE	DIMENSIONS (mm)										WEIGHT			
	DNA	DNM	b1	h1	h2	h3	l1	p	x	B	H	L	k	kg
FCTE 40-125/07/D	40	40	245	170	50	120	89	155	250	490	320	452	90	56
FCTE 40-125/11/D	40	40	245	170	50	120	89	155	250	490	320	452	90	58
FCTE 40-160/15/D	40	40	245	170	50	120	89	155	250	490	320	452	90	60
FCTE 40-160/22/C	40	40	245	170	50	120	89	174	250	490	320	487	90	69
FCTE 40-200/40A/P	40	40	348	220	50	190	97	197	360	695	440	516	101	139
FCTE 40-200/40/P	40	40	348	220	50	190	97	197	360	695	440	516	101	139
FCTE 40-200/55/P	40	40	348	220	50	190	97	214	360	695	440	550	101	141
FCTE 40-250/75/P	40	40	348	220	50	190	97	256	360	695	440	564	101	177
FCTE 40-250/110/P	40	40	348	220	50	190	97	256	360	695	440	602	101	179
FCTE 50-125/11/D	50	50	250	180	55	130	92	155	260	500	340	457	91	57
FCTE 50-125/15/D	50	50	250	180	55	130	92	155	260	500	340	457	91	63
FCTE 50-160/22/C	50	50	250	180	55	130	92	174	260	500	340	492	91	82
FCTE 50-160/30/P	50	50	250	180	55	130	92	174	260	500	340	491	91	85
FCTE 50-160/40/P	50	50	250	180	55	130	92	197	260	500	340	512	91	91
FCTE 50-200/55/P	50	50	348	230	60	185	125	214	360	695	440	578	110	108
FCTE 50-200/75/P	50	50	348	230	60	185	125	256	360	695	440	592	110	140
FCTE 50-250/92/P	50	50	348	230	60	185	125	256	360	695	440	630	110	198
FCTE 50-250/110/P	50	50	348	230	60	185	125	256	360	695	440	630	110	210
FCTE 50-250/150/P	50	50	348	230	60	185	125	313	360	695	440	719	110	226
FCTE 65-125/22/C	65	65	297	185	55	125	108	174	310	593	340	509	96	108
FCTE 65-125/30/P	65	65	297	185	55	125	108	174	310	593	340	509	96	113
FCTE 65-125/40/P	65	65	297	185	55	125	108	197	310	593	340	530	96	121
FCTE 65-160/55/P	65	65	297	185	55	125	108	214	310	593	340	564	96	137
FCTE 65-160/75/P	65	65	297	185	55	125	108	256	310	593	340	578	96	171
FCTE 65-200/92/P	65	65	348	260	59	185	130	256	360	695	475	635	109	202
FCTE 65-200/110/P	65	65	348	260	59	185	130	256	360	695	475	635	109	216
FCTE 65-250/150/P	65	65	348	260	59	185	130	313	360	695	475	724	109	248
FCTE 65-250/185/P	65	65	348	260	59	185	130	313	360	695	475	724	109	252
FCTE 65-250/220/P	65	65	348	260	59	185	130	313	360	695	475	724	109	272
FCTE 80-125/30/P	80	80	304	210	70	110	141	174	320	607	400	548	106	127
FCTE 80-125/40/P	80	80	304	210	70	110	141	197	320	607	400	569	106	133
FCTE 80-125/55/P	80	80	304	210	70	110	141	214	320	607	400	603	106	137
FCTE 80-160/75/P	80	80	304	210	70	110	141	256	320	607	400	617	106	169
FCTE 80-200/110/P	80	80	368	280	80	140	157	256	380	722	500	662	112	231
FCTE 80-200/150/P	80	80	368	280	80	140	157	313	380	722	500	751	112	251
FCTE 80-200/185/P	80	80	368	280	80	140	157	313	380	722	500	751	112	271
FCTE 80-200/220/P	80	80	368	280	80	140	157	313	380	722	500	751	112	295
FCTE 100-160/110/P	100	100	340	270	72	150	175	256	360	670	500	681	118	252
FCTE 100-200/185/P	100	100	408	310	80	150	180	313	410	798	550	774	128	363
FCTE 100-200/220/P	100	100	408	310	80	150	180	313	410	798	550	774	128	387

fct_fcte-2p50-en_d_td

**FCTE4 SERIES
DIMENSIONS AND WEIGHTS AT 50 Hz**

CLEARANCE FOR DISASSEMBLY

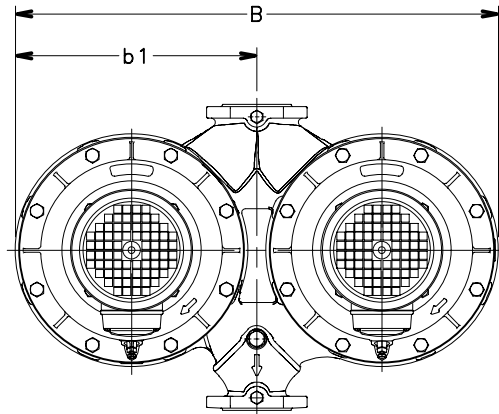
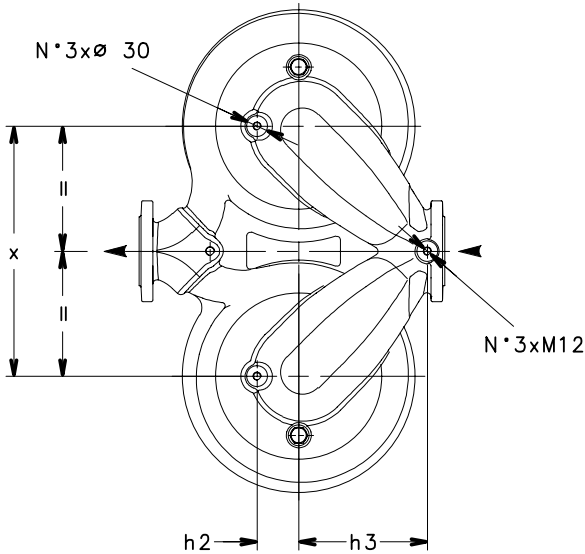
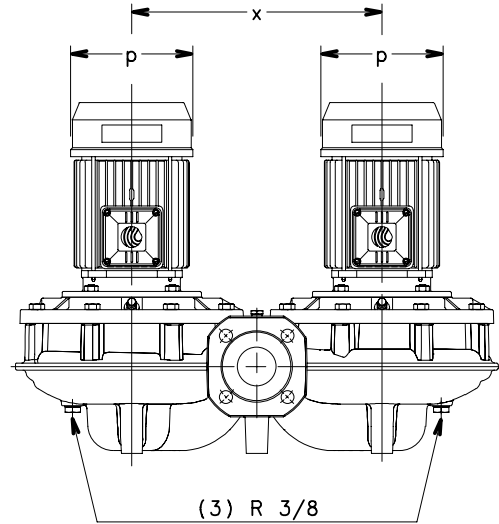
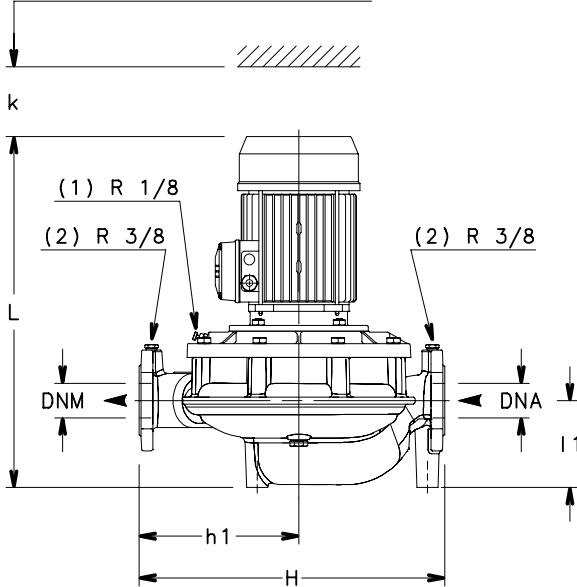

- (1) AIR VALVE
- (2) PRESSURE GAUGE CONNECTOR
- (3) DRAIN

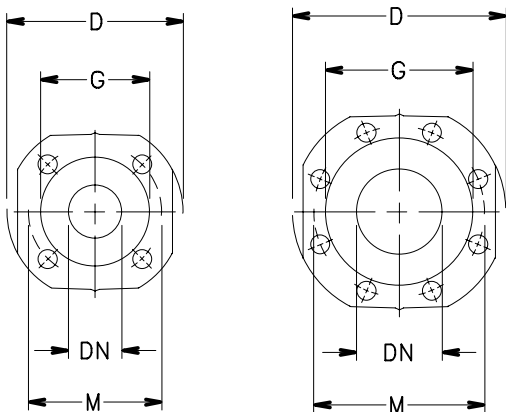

PUMP FLANGES

DN	D	M	G	HOLES		THICKNESS MAX.
				N°	DIA.	
40	150	110	88	4	18	18
50	165	125	102	4	18	20
65	185	145	122	4	18	20
80	200	160	138	8	18	22
100	220	180	158	8	18	22

05205-EN_A_DD

FCTE4 SERIES DIMENSIONS AND WEIGHTS AT 50 Hz

PUMP TYPE	DIMENSIONS (mm)										WEIGHT			
	DNA	DNM	b1	h1	h2	h3	l1	p	x	B	H	L	k	kg
FCTE4 40-125/02A	40	40	245	170	50	120	89	140	250	490	320	420	90	46
FCTE4 40-125/02	40	40	245	170	50	120	89	140	250	490	320	420	90	46
FCTE4 40-160/02	40	40	245	170	50	120	89	140	250	490	320	420	90	48
FCTE4 40-160/03	40	40	245	170	50	120	89	140	250	490	320	420	90	50
FCTE4 40-200/05	40	40	348	220	50	190	97	155	360	695	440	460	101	83
FCTE4 40-200/07/C	40	40	348	220	50	190	97	159	360	695	440	428	101	86
FCTE4 40-250/11/P	40	40	348	220	50	190	97	174	360	695	440	495	101	123
FCTE4 40-250/15/P	40	40	348	220	50	190	97	174	360	695	440	495	101	125
FCTE4 50-125/02	50	50	250	180	55	130	92	140	260	500	340	425	91	49
FCTE4 50-125/03	50	50	250	180	55	130	92	140	260	500	340	425	91	51
FCTE4 50-160/05	50	50	250	180	55	130	92	155	260	500	340	457	91	53
FCTE4 50-200/07/C	50	50	348	230	60	185	125	159	360	695	440	456	110	105
FCTE4 50-200/11/P	50	50	348	230	60	185	125	174	360	695	440	523	110	122
FCTE4 50-250/15/P	50	50	348	230	60	185	125	174	360	695	440	523	110	128
FCTE4 50-250/22/P	50	50	348	230	60	185	125	214	360	695	440	547	110	140
FCTE4 65-125/03	65	65	297	185	55	125	108	140	310	593	340	442	96	75
FCTE4 65-125/05	65	65	297	185	55	125	108	155	310	593	340	474	96	83
FCTE4 65-160/07/C	65	65	297	185	55	125	108	159	310	593	340	442	96	94
FCTE4 65-160/11/P	65	65	297	185	55	125	108	174	310	593	340	509	96	107
FCTE4 65-200/15/P	65	65	348	260	59	185	130	174	360	695	475	528	109	130
FCTE4 65-250/22/P	65	65	348	260	59	185	130	214	360	695	475	552	109	152
FCTE4 65-250/30/P	65	65	348	260	59	185	130	214	360	695	475	583	109	156
FCTE4 80-125/07/C	80	80	304	210	70	110	141	159	320	607	400	481	106	101
FCTE4 80-125/11/P	80	80	304	210	70	110	141	174	320	607	400	548	106	116
FCTE4 80-200/15/P	80	80	368	280	80	140	157	174	380	722	500	555	112	153
FCTE4 80-200/22/P	80	80	368	280	80	140	157	214	380	722	500	579	112	165
FCTE4 80-200/30/P	80	80	368	280	80	140	157	214	380	722	500	610	112	173
FCTE4 80-250/40/P	80	80	368	280	80	140	157	214	380	722	500	655	112	225
FCTE4 80-250/55/P	80	80	368	280	80	140	157	256	380	722	500	662	112	241
FCTE4 100-160/15/P	100	100	340	270	72	150	175	174	360	670	500	574	118	146
FCTE4 100-200/22/P	100	100	408	310	80	150	180	214	410	798	550	602	128	201
FCTE4 100-200/30/P	100	100	408	310	80	150	180	214	410	798	550	633	128	205
FCTE4 100-250/40/P	100	100	408	310	80	150	180	214	410	798	550	678	128	253
FCTE4 100-250/55/P	100	100	408	310	80	150	180	256	410	798	550	685	128	265
FCTE4 100-250/75/P	100	100	408	310	80	150	180	256	410	798	550	685	128	285

ftc_fcte4-4p50-en_d_td

FCTS SERIES DIMENSIONS AND WEIGHTS AT 50 Hz

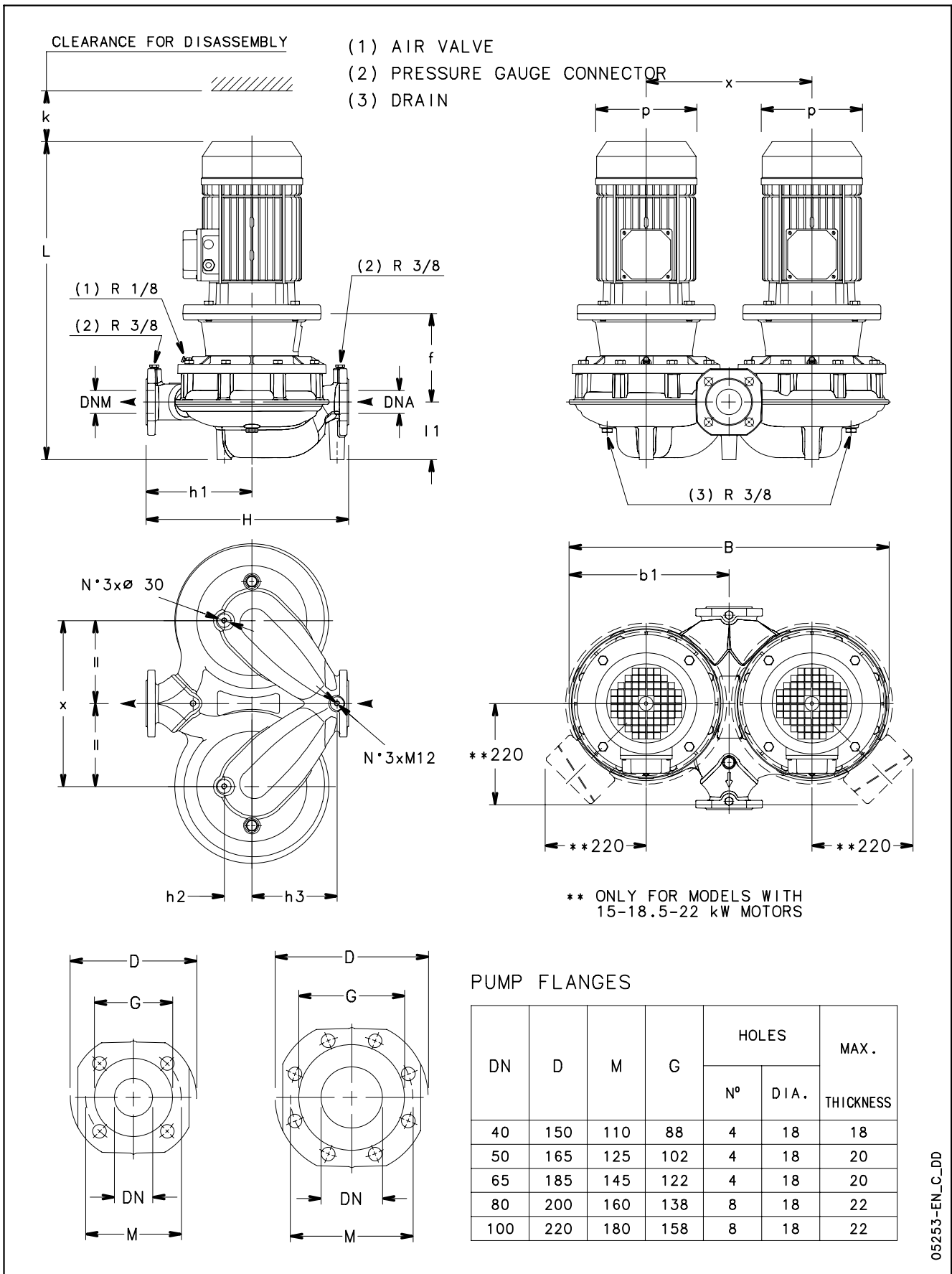

05253-EN_C_DD

FCTS SERIES

DIMENSIONS AND WEIGHTS AT 50 Hz

PUMP TYPE	DIMENSIONS (mm)											WEIGHT			
	DNA	DNM	b1	f	h1	h2	h3	l1	p	x	B	H	L	k	kg
FCTS 40-125/07/D	40	40	245	155	170	50	120	89	155	250	490	320	507	90	62
FCTS 40-125/11/D	40	40	245	155	170	50	120	89	155	250	490	320	507	90	64
FCTS 40-160/15/D	40	40	245	155	170	50	120	89	155	250	490	320	507	90	66
FCTS 40-160/22/C	40	40	245	155	170	50	120	89	174	250	490	320	542	90	77
FCTS 40-200/30/P	40	40	348	165	220	50	190	97	174	360	695	440	560	101	133
FCTS 40-200/40/P	40	40	348	165	220	50	190	97	197	360	695	440	581	101	145
FCTS 40-200/55/P	40	40	348	192	220	50	190	97	214	360	695	440	664	101	171
FCTS 40-250/75/P	40	40	348	192	220	50	190	97	256	360	695	440	656	101	207
FCTS 40-250/110/P	40	40	348	222	220	50	190	97	256	360	695	440	747	101	235
FCTS 50-125/11/D	50	50	250	156	180	55	130	92	155	260	500	340	511	91	67
FCTS 50-125/15/D	50	50	250	156	180	55	130	92	155	260	500	340	511	91	69
FCTS 50-160/22/C	50	50	250	156	180	55	130	92	174	260	500	340	546	91	94
FCTS 50-160/30/P	50	50	250	166	180	55	130	92	174	260	500	340	556	91	95
FCTS 50-160/40/P	50	50	250	166	180	55	130	92	197	260	500	340	577	91	109
FCTS50-200/55/P	50	50	348	192	230	60	185	125	214	360	695	440	692	110	178
FCTS 50-200/75/P	50	50	348	192	230	60	185	125	256	360	695	440	684	110	212
FCTS 50-250/110A/P	50	50	348	222	230	60	185	125	256	360	695	440	775	110	226
FCTS 50-250/110/P	50	50	348	222	230	60	185	125	256	360	695	440	775	110	226
FCTS 50-250/150/P	50	50	348	222	230	60	185	125	313	360	695	440	841	110	246
FCTS 65-125/22/C	65	65	297	158	185	55	125	108	174	310	593	340	564	96	138
FCTS 65-125/30/P	65	65	297	168	185	55	125	108	174	310	593	340	574	96	123
FCTS 65-125/40/P	65	65	297	168	185	55	125	108	197	310	593	340	595	96	133
FCTS 65-160/55/P	65	65	297	195	185	55	125	108	214	310	593	340	678	96	159
FCTS 65-160/75/P	65	65	297	195	185	55	125	108	256	310	593	340	670	96	189
FCTS 65-200/110A/P	65	65	348	222	260	59	185	130	256	360	695	475	780	109	258
FCTS 65-200/110/P	65	65	348	222	260	59	185	130	256	360	695	475	780	109	258
FCTS 65-250/150/P	65	65	348	222	260	59	185	130	313	360	695	475	846	109	260
FCTS 65-250/185/P	65	65	348	222	260	59	185	130	313	360	695	475	846	109	272
FCTS 65-250/220/P	65	65	348	222	260	59	185	130	313	360	695	475	846	109	292
FCTS 80-125/30/P	80	80	304	174	210	70	110	141	174	320	607	400	613	106	162
FCTS 80-125/40/P	80	80	304	174	210	70	110	141	197	320	607	400	634	106	164
FCTS 80-125/55/P	80	80	304	201	210	70	110	141	214	320	607	400	717	106	170
FCTS 80-160/75/P	80	80	304	201	210	70	110	141	256	320	607	400	709	106	202
FCTS 80-200/110/P	80	80	368	222	280	80	140	157	256	380	722	500	807	112	251
FCTS 80-200/150/P	80	80	368	222	280	80	140	157	313	380	722	500	873	112	271
FCTS 80-200/185/P	80	80	368	222	280	80	140	157	313	380	722	500	873	112	291
FCTS 80-200/220/P	80	80	368	222	280	80	140	157	313	380	722	500	873	112	315
FCTS 100-160/110/P	100	100	340	223	270	72	150	175	256	360	670	500	826	118	268
FCTS 100-200/185/P	100	100	408	222	310	80	150	180	313	410	798	550	896	128	384
FCTS 100-200/220/P	100	100	408	222	310	80	150	180	313	410	798	550	896	128	407

fct_fcts-2p50-en_d_td

FCTS4 SERIES
DIMENSIONS AND WEIGHTS AT 50 Hz

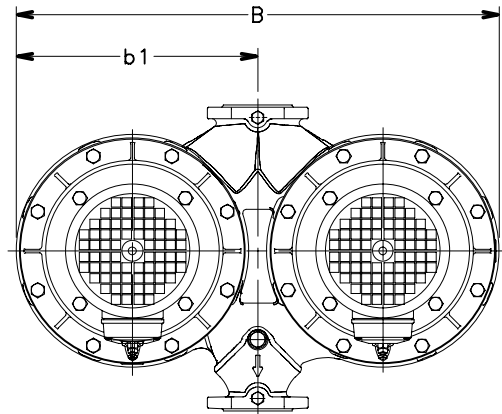
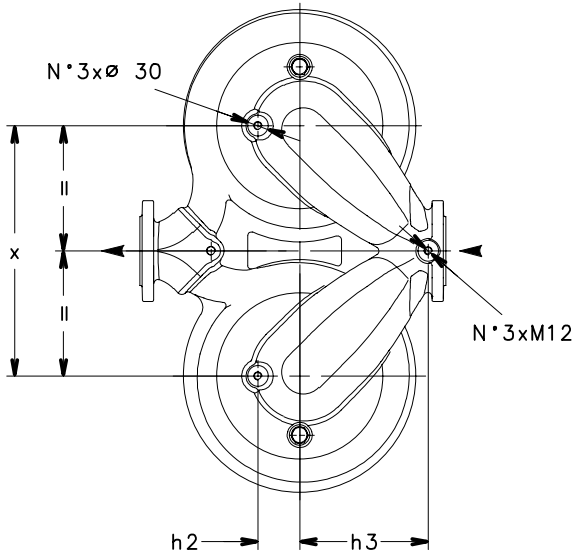
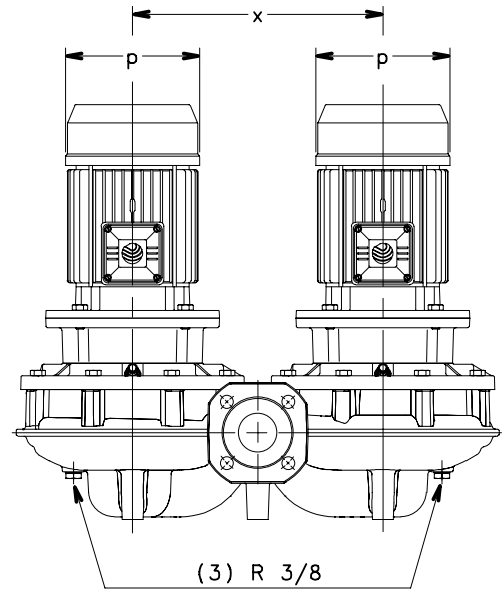
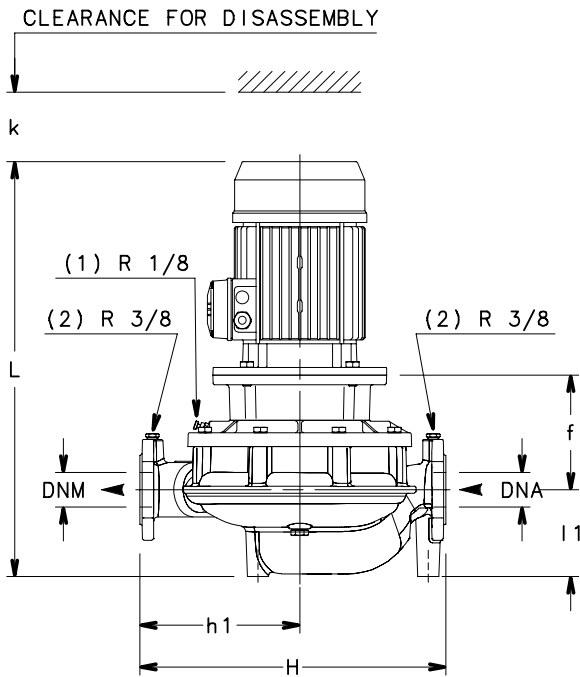

- (1) AIR VALVE
- (2) PRESSURE GAUGE CONNECTOR
- (3) DRAIN

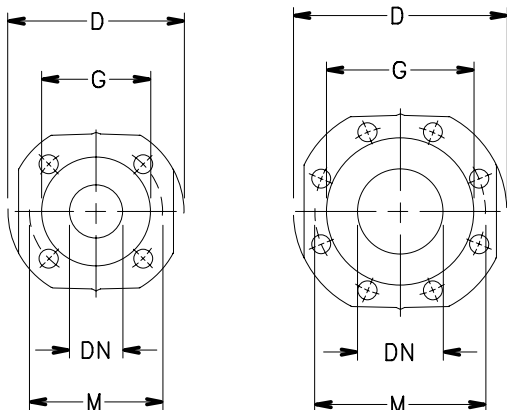

PUMP FLANGES

DN	D	M	G	HOLES		THICKNESS MAX.
				N°	DIA.	
40	150	110	88	4	18	18
50	165	125	102	4	18	20
65	185	145	122	4	18	20
80	200	160	138	8	18	22
100	220	180	158	8	18	22

05254-EN_A_DD

FCTS4 SERIES

DIMENSIONS AND WEIGHTS AT 50 Hz

PUMP TYPE	DIMENSIONS (mm)											WEIGHT			
	DNA	DNM	b1	f	h1	h2	h3	l1	p	x	B	H max	L	k	kg
FCTS4 40-200/05	40	40	348	155	220	50	190	97	155	360	695	440	515	101	107
FCTS4 40-200/07/C	40	40	348	155	220	50	190	97	159	360	695	440	483	101	116
FCTS4 40-250/11/P	40	40	348	155	220	50	190	97	174	360	695	440	550	101	129
FCTS4 40-250/15/P	40	40	348	155	220	50	190	97	174	360	695	440	550	101	133
FCTS4 50-200/07/C	50	50	348	155	230	60	185	125	159	360	695	440	511	110	123
FCTS4 50-200/11/P	50	50	348	155	230	60	185	125	174	360	695	440	578	110	140
FCTS4 50-250/15/P	50	50	348	155	230	60	185	125	174	360	695	440	578	110	142
FCTS4 50-250/22/P	50	50	348	165	230	60	185	125	214	360	695	440	612	110	152
FCTS4 65-160/07/C	65	65	297	158	185	55	125	108	159	310	593	340	497	96	98
FCTS4 65-160/11/P	65	65	297	158	185	55	125	108	174	310	593	340	564	96	109
FCTS4 65-200/15/P	65	65	348	155	260	59	185	130	174	360	695	475	583	109	136
FCTS4 65-250/22/P	65	65	348	165	260	59	185	130	214	360	695	475	617	109	160
FCTS4 65-250/30/P	65	65	348	165	260	59	185	130	214	360	695	475	648	109	166
FCTS4 80-125/07/C	80	80	304	164	210	70	110	141	159	320	607	400	536	106	109
FCTS4 80-125/11/P	80	80	304	164	210	70	110	141	174	320	607	400	603	106	130
FCTS4 80-200/15/P	80	80	368	155	280	80	140	157	174	380	722	500	610	112	175
FCTS4 80-200/22/P	80	80	368	165	280	80	140	157	214	380	722	500	644	112	181
FCTS4 80-200/30/P	80	80	368	165	280	80	140	157	214	380	722	500	675	112	185
FCTS4 80-250/40/P	80	80	368	165	280	80	140	157	214	380	722	500	720	112	241
FCTS4 80-250/55/P	80	80	368	192	280	80	140	157	256	380	722	500	754	112	249
FCTS4 100-160/15/P	100	100	340	156	270	72	150	175	174	360	670	500	629	118	154
FCTS4 100-200/22/P	100	100	408	165	310	80	150	180	214	410	798	550	667	128	173
FCTS4 100-200/30/P	100	100	408	165	310	80	150	180	214	410	798	550	698	128	179
FCTS4 100-250/40/P	100	100	408	165	310	80	150	180	214	410	798	550	743	128	283
FCTS4 100-250/55/P	100	100	408	192	310	80	150	180	256	410	798	550	777	128	287
FCTS4 100-250/75/P	100	100	408	192	310	80	150	180	256	410	798	550	777	128	297

fct_fcts4-4p50-en_e_td

FCTS4 (125÷150) SERIES DIMENSIONS AND WEIGHTS AT 50 Hz

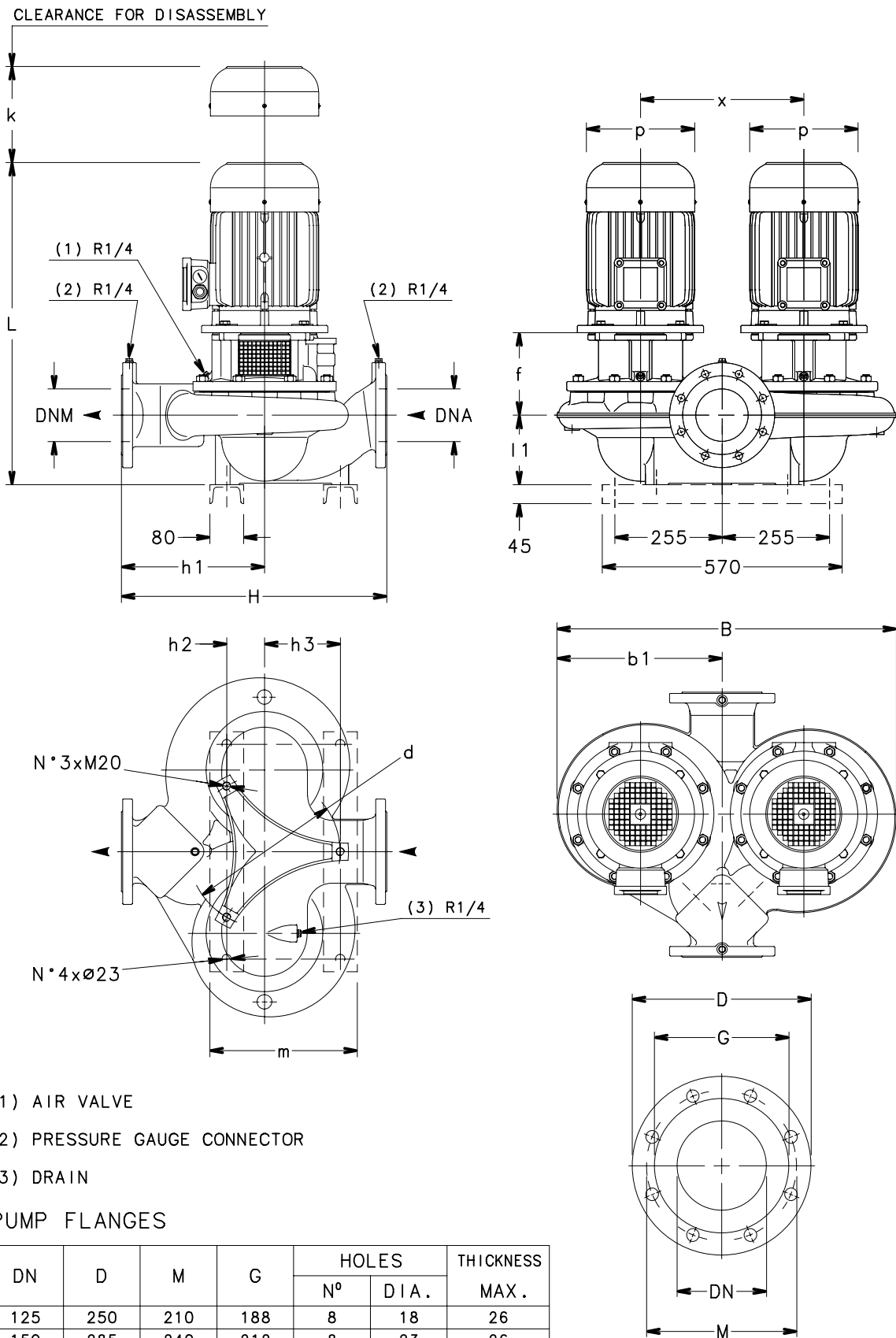

05255_A_DD

FCTS4 (125÷150) SERIES

DIMENSIONS AND WEIGHTS AT 50 Hz

PUMP TYPE	PUMP DIMENSIONS (mm)													WEIGHT			
	DNA	DNM	b1	d	f	h ₁	h ₂	h ₃	l ₁	m	p	x	B	H	L	k	kg
FCTS4 125-160/30/P	125	125	422	360	196	350	90	180	175	350	214	386	800	630	724	143	254
FCTS4 125-200/40/P	125	125	368	360	196	330	90	180	160	350	214	349	716	620	754	153	252
FCTS4 125-200/55/P	125	125	368	360	196	330	90	180	160	350	256	349	716	620	761	153	294
FCTS4 125-250/75/P	125	125	412	360	196	340	90	180	165	350	256	388	805	630	766	150	325
FCTS4 125-250/110/P	125	125	412	360	226	340	90	180	165	350	313	388	805	630	885	150	453
FCTS4 150-200/55/P	150	150	471	460	211	400	115	230	175	425	256	440	900	720	791	160	356
FCTS4 150-200/75/P	150	150	471	460	211	400	115	230	175	425	256	440	900	720	791	160	350
FCTS4 150-250/110/P	150	150	498	460	226	405	115	230	200	425	313	466	963	755	920	158	532
FCTS4 150-250/150/P	150	150	498	460	226	405	115	230	200	425	313	466	963	755	920	158	538
FCTS4 150-250/185/C	150	150	498	460	226	405	115	230	200	425	360	466	963	755	980	158	610

lmz_fcts4-4p50-en_e_td

ACCESSORIES

**FC-FCT SERIES
ROUND THREADED COUNTERFLANGES ACCORDING TO EN 1092-1**

DN	ø C	DIMENSIONS (mm)				HOLES		
		ø A	B	ø D	H	ø F	N°	PN
40	Rp 1½	110	14	150	19	18	4	16
50	Rp 2	125	16	165	24	18	4	16
65	Rp 2½	145	16	185	23	18	4	16
80	Rp 3	160	17	200	27	18	8	16
100	Rp 4	180	18	220	31	18	8	16

fc-fct-ctf-tonde-f-en_a_td

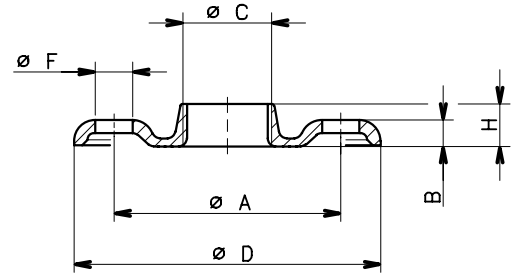

04430_B_DD

**FC-FCT SERIES
ROUND WELD COUNTERFLANGES ACCORDING TO EN 1092-1**

DN	ø C	DIMENSIONS (mm)				HOLES		
		ø A	B	ø D	ø F	N°	PN	
65	77	145	18	185	18	4	16	
80	90	160	20	200	18	8	16	
100	115,5	180	22	220	18	8	16	
125	141,5	210	22	250	18	8	16	
150	170,5	240	24	285	22	8	16	

fc-fct-ctf-tonde-s-en_a_td

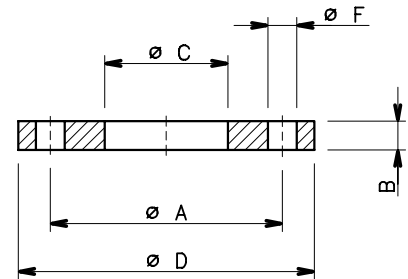

04431_A_DD

**FCT SERIES
BLIND FLANGE KIT**

FLANGE KIT		
PUMP TYPE	CODE	ø D
FCT40-125 / FCT40-160	109393750	225
FCT50-125 / FCT50-160		
FCT65-125 / FCT65-160	109393760	274
FCT80-125 / FCT80-160		
FCT100-160	109393770	322
FCT40-200 / FCT40-250		
FCT50-200 / FCT50-250		
FCT65-200 / FCT65-250		
FCT80-200 / FCT80-250		
FCT100-200 / FCT100-250	109393800	280
FCT125-160 / FCT125-200		
FCT150-200	109393810	305
FCT125-250 / FCT150-250	109393820	350

fct-flangia-cieca-en_a_td

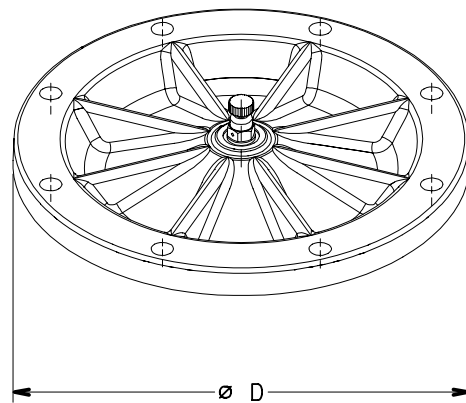

05262_A_DD

**FC SERIES
MOUNTING BASE**

04803B_A_DD

04803_A_DD

**FC (40÷100) SERIES
MOUNTING BASE KIT**

PUMP TYPE
FCE-FCS 40-200, 40-250
FCE-FCS 50-200, 50-250
FCE-FCS 65-200, 65-250
FCE-FCS 80-200, 80-250
FCE-FCS 100-200, 100-250

fc_base-lw-en_c_td

**FC (125÷150) SERIES
MOUNTING BASE KIT**

PUMP TYPE	DIMENSIONS (mm)								
	R	D	D1	D2	H	H1	H2	H3	S
FCS4 125-160, 125-200	273	410	384	274	120	20	14	183	14
FCS4 125-250, 125-315, 150-200, 150-250	333	480	450	320	140	23	15	212	18

fc_base-vo-en_c_td

**FC SERIES
BRACKETS**

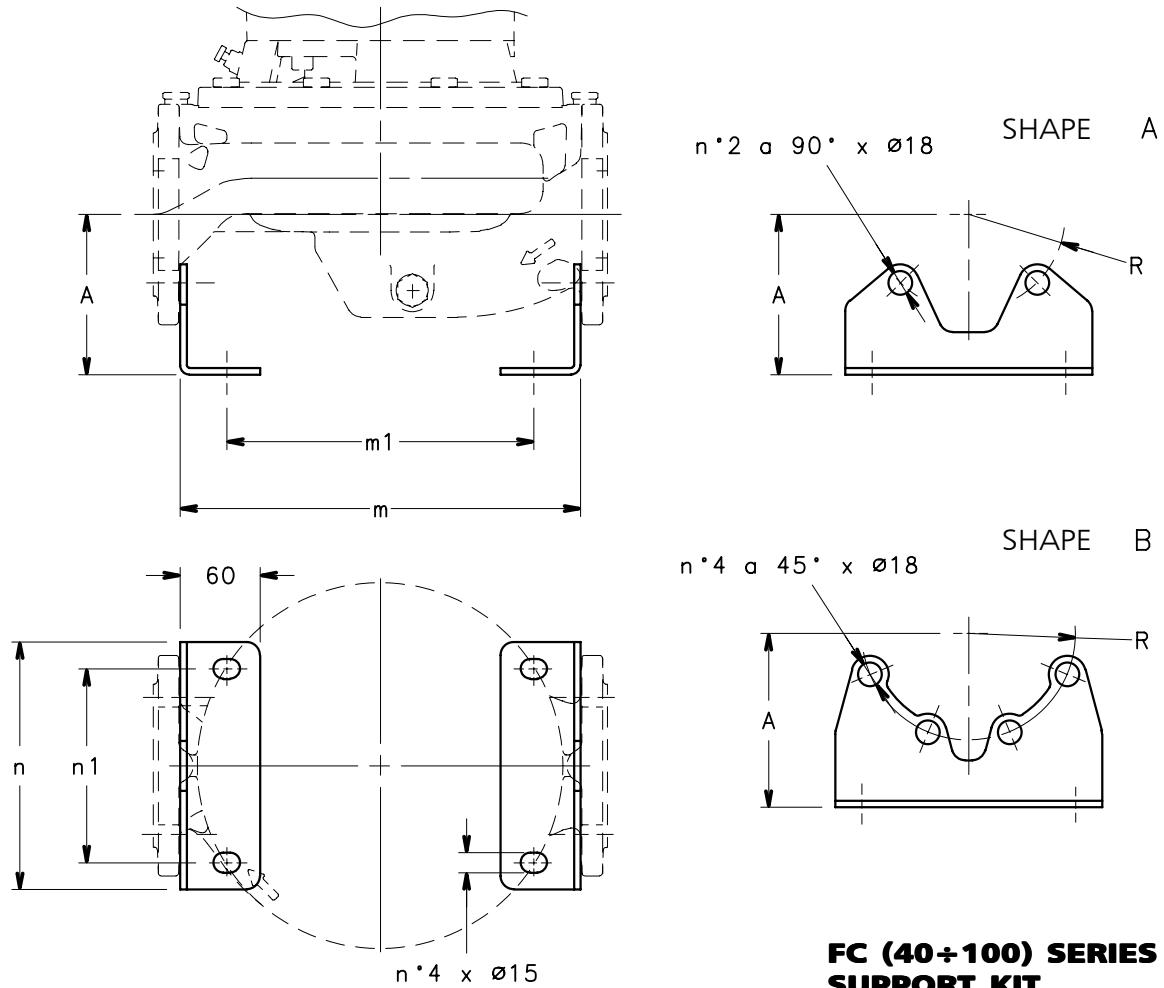

**FC (40+100) SERIES
SUPPORT KIT**

PUMP TYPE		SHAPE	DIMENSIONS (mm)				
			A	m	m1	n	n1
FCE 40-125 / FCE 40-160	FCE4 40-125 / FCE4 40-160	A	100	284	210	150	110
FCS 40-125 / FCS 40-160	FCS4 40-125 / FCS4 40-160						
FCE 40-200 / FCE 40-250	FCE4 40-200 / FCE4 40-250	A	100	404	330	150	110
FCS 40-200 / FCS 40-250	FCS4 40-200 / FCS4 40-250						
FCE 50-125 / FCE 50-160	FCE4 50-125 / FCE4 50-160	A	110	300	230	165	125
FCS 50-125 / FCS 50-160	FCS4 50-125 / FCS4 50-160						
FCE 50-200 / FCE 50-250	FCE4 50-200 / FCE4 50-250	A	110	400	330	165	125
FCS 50-200 / FCS 50-250	FCS4 50-200 / FCS4 50-250						
FCE 65-125 / FCE 65-160	FCE4 65-125 / FCE4 65-160	A	120	300	230	185	145
FCS 65-125 / FCS 65-160	FCS4 65-160						
FCE 65-200 / FCE 65-250	FCE4 65-200 / FCE4 65-250	A	120	435	365	185	145
FCS 65-200 / FCS 65-250	FCS4 65-200 / FCS4 65-250						
FCE 80-125 / FCE 80-160	FCE4 80-125	B	130	316	250	200	160
FCS 80-125 / FCS 80-160	FCS4 80-125						
FCE 80-200	FCE4 80-200 / FCE4 80-250	B	130	456	390	200	160
FCS 80-200	FCS4 80-200 / FCS4 80-250						
FCE 100-160	FCE4 100-160	B	140	402	330	220	180
FCS 100-160	FCS4 100-160						
FCE 100-200	FCE4 100-200 / FCE4 100-250	B	140	502	430	220	180
FCS 100-200	FCS4 100-200 / FCS4 100-250						

fc_staffe-en_a_td

04855_A_DD

FCT (40÷100) SERIES MOUNTING BASE KIT

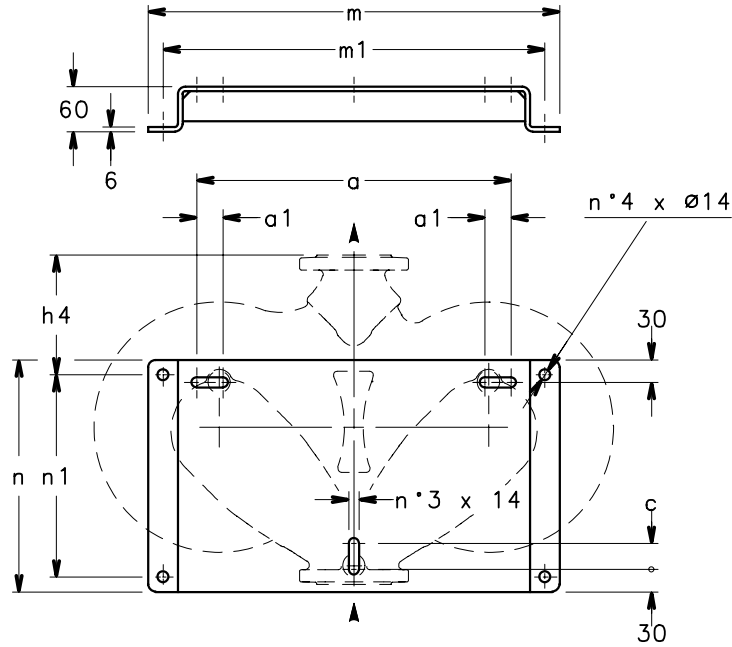

PUMP SIZE	DIMENSIONS (mm)							
	a	a1	c	h4	m	m1	n	n1
40-125 / 40-160	330	45	25	110	460	420	250	210
50-125 / 50-160	330	45	25	115	460	420	250	210
65-125 / 65-160	330	45	25	120	460	420	250	210
80-125 / 80-160	330	45	25	130	460	420	250	210
100-160	420	35	35	188	550	510	310	270
40-200 / 40-250	420	35	35	160	550	510	310	270
50-200 / 50-250	420	35	35	160	550	510	310	270
65-200 / 65-250	420	35	35	191	550	510	310	270
80-200 / 80-250	420	35	35	190	550	510	310	270
100-200 / 100-250	420	35	35	220	550	510	310	270

fct-piede-en_a_td

05260_A_DD

FCT (125÷150) SERIES MOUNTING BASE KIT

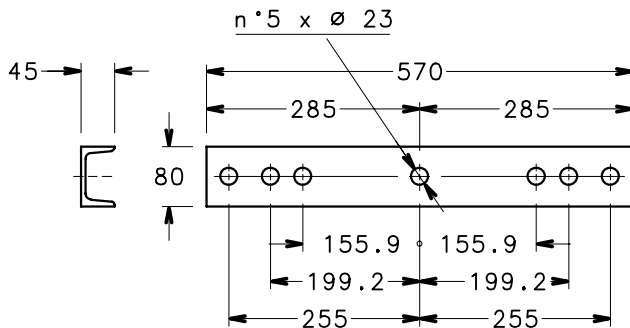

PUMP TYPE	DIMENSIONS (mm)		
	h4	h5	m
FCTS4 125-160	260	270	350
FCTS4 125-200	240	270	350
FCTS4 125-250	250	270	350
FCTS4 150-200	285	345	425
FCTS4 150-250	290	345	425

lmz-fcts4-piede-en_b_td

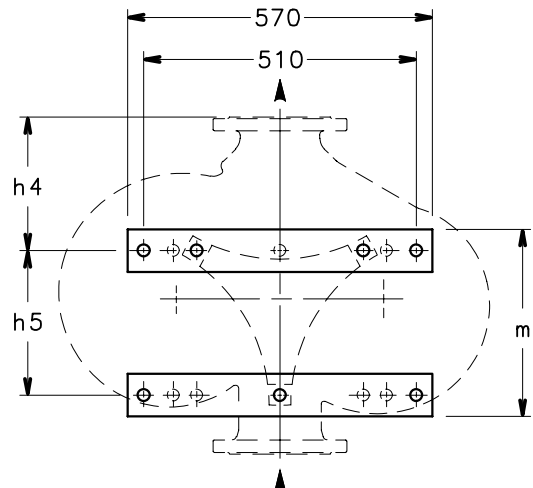

05261_A_DD

TECHNICAL APPENDIX

TYPICAL APPLICATIONS OF FC, FCT SERIES ELECTRIC PUMPS:

Heating, Ventilating &

Air Conditioning (HVAC):

Condensate return
Air scrubbers
Water re-circulation
Cooling towers
Cooling systems
Temperature control
Chillers
Induction heating
Heat exchangers
Water heating
Booster packagers

Graphics:

Film washing
Cooling of presses

Waste Management:

Waste treatment
Pollution control

Agriculture:

Irrigation
Greenhouses
Cotton humidifiers

Laundry:

Commercial washing

NPSH

The minimum operating values that can be reached at the pump suction end are limited by the onset of cavitation.

Cavitation is the formation of vapour-filled cavities within liquids where the pressure is locally reduced to a critical value, or where the local pressure is equal to, or just below the vapour pressure of the liquid.

The vapour-filled cavities flow with the current and when they reach a higher pressure area the vapour contained in the cavities condenses. The cavities collide, generating pressure waves that are transmitted to the walls. These, being subjected to stress cycles, gradually become deformed and yield due to fatigue. This phenomenon, characterized by a metallic noise produced by the hammering on the pipe walls, is called incipient cavitation.

The damage caused by cavitation may be magnified by electrochemical corrosion and a local rise in temperature due to the plastic deformation of the walls. The materials that offer the highest resistance to heat and corrosion are alloy steels, especially austenitic steel. The conditions that trigger cavitation may be assessed by calculating the total net suction head, referred to in technical literature with the acronym NPSH (Net Positive Suction Head).

The NPSH represents the total energy (expressed in m.) of the liquid measured at suction under conditions of incipient cavitation, excluding the vapour pressure (expressed in m.) that the liquid has at the pump inlet.

To find the static height h_z at which to install the machine under safe conditions, the following formula must be verified:

$$h_p + h_z \geq (\text{NPSH}_r + 0.5) + h_f + h_{pv} \quad \textcircled{1}$$

where:

- h_p** is the absolute pressure applied to the free liquid surface in the suction tank, expressed in m. of liquid; h_p is the quotient between the barometric pressure and the specific weight of the liquid.
- h_z** is the suction lift between the pump axis and the free liquid surface in the suction tank, expressed in m.; h_z is negative when the liquid level is lower than the pump axis.
- h_f** is the flow resistance in the suction line and its accessories, such as: fittings, foot valve, gate valve, elbows, etc.
- h_{pv}** is the vapour pressure of the liquid at the operating temperature, expressed in m. of liquid. h_{pv} is the quotient between the Pv vapour pressure and the liquid's specific weight.
- 0,5** is the safety factor.

The maximum possible suction head for installation depends on the value of the atmospheric pressure (i.e. the elevation above sea level at which the pump is installed) and the temperature of the liquid.

To help the user, with reference to water temperature (4° C) and to the elevation above sea level, the following tables show the drop in hydraulic pressure head in relation to the elevation above sea level, and the suction loss in relation to temperature.

Water temperature (°C)	20	40	60	80	90	110	120
Suction loss (m)	0,2	0,7	2,0	5,0	7,4	15,4	21,5

Elevation above sea level (m)	500	1000	1500	2000	2500	3000
Suction loss (m)	0,55	1,1	1,65	2,2	2,75	3,3

Friction loss is shown in the tables at pages 127-128 of this catalogue. To reduce it to a minimum, especially in cases of high suction head (over 4-5 m.) or within the operating limits with high flow rates, we recommend using a suction line having a larger diameter than that of the pump's suction port. It is always a good idea to position the pump as close as possible to the liquid to be pumped.

Make the following calculation:

Liquid: water at ~15°C $\gamma = 1 \text{ kg/dm}^3$

Flow rate required: 30 m³/h

Head for required delivery: 43 m.

Suction lift: 3,5 m.

The selection is an FHE 40-200/75 pump whose NPSH required value is, at 30 m³/h, di 2,5 m.

For water at 15 °C

$$h_p = P_a / \gamma = 10,33\text{m}, h_{pv} = P_v / \gamma = 0,174\text{m} (0,01701 \text{ bar})$$

The H_f flow resistance in the suction line with foot valves is ~ 1,2 m.

By substituting the parameters in formula $\textcircled{1}$ with the numeric values above, we have:

$$10,33 + (-3,5) \geq (2,5 + 0,5) + 1,2 + 0,17$$

from which we have: 6,8 > 4,4

The relation is therefore verified.

TECHNICAL APPENDIX VAPOUR PRESSURE PS VAPOUR PRESSURE AND ρ DENSITY OF WATER TABLE

t °C	T K	ps bar	ρ kg/dm ³	t °C	T K	ps bar	ρ kg/dm ³	t °C	T K	ps bar	ρ kg/dm ³
0	273,15	0,00611	0,9998	55	328,15	0,15741	0,9857	120	393,15	1,9854	0,9429
1	274,15	0,00657	0,9999	56	329,15	0,16511	0,9852	122	395,15	2,1145	0,9412
2	275,15	0,00706	0,9999	57	330,15	0,17313	0,9846	124	397,15	2,2504	0,9396
3	276,15	0,00758	0,9999	58	331,15	0,18147	0,9842	126	399,15	2,3933	0,9379
4	277,15	0,00813	1,0000	59	332,15	0,19016	0,9837	128	401,15	2,5435	0,9362
5	278,15	0,00872	1,0000	60	333,15	0,1992	0,9832	130	403,15	2,7013	0,9346
6	279,15	0,00935	1,0000	61	334,15	0,2086	0,9826	132	405,15	2,867	0,9328
7	280,15	0,01001	0,9999	62	335,15	0,2184	0,9821	134	407,15	3,041	0,9311
8	281,15	0,01072	0,9999	63	336,15	0,2286	0,9816	136	409,15	3,223	0,9294
9	282,15	0,01147	0,9998	64	337,15	0,2391	0,9811	138	411,15	3,414	0,9276
10	283,15	0,01227	0,9997	65	338,15	0,2501	0,9805	140	413,15	3,614	0,9258
11	284,15	0,01312	0,9997	66	339,15	0,2615	0,9799	145	418,15	4,155	0,9214
12	285,15	0,01401	0,9996	67	340,15	0,2733	0,9793	155	428,15	5,433	0,9121
13	286,15	0,01497	0,9994	68	341,15	0,2856	0,9788	160	433,15	6,181	0,9073
14	287,15	0,01597	0,9993	69	342,15	0,2984	0,9782	165	438,15	7,008	0,9024
15	288,15	0,01704	0,9992	70	343,15	0,3116	0,9777	170	443,15	7,920	0,8973
16	289,15	0,01817	0,9990	71	344,15	0,3253	0,9770	175	448,15	8,924	0,8921
17	290,15	0,01936	0,9988	72	345,15	0,3396	0,9765	180	453,15	10,027	0,8869
18	291,15	0,02062	0,9987	73	346,15	0,3543	0,9760	185	458,15	11,233	0,8815
19	292,15	0,02196	0,9985	74	347,15	0,3696	0,9753	190	463,15	12,551	0,8760
20	293,15	0,02337	0,9983	75	348,15	0,3855	0,9748	195	468,15	13,987	0,8704
21	294,15	0,24850	0,9981	76	349,15	0,4019	0,9741	200	473,15	15,550	0,8647
22	295,15	0,02642	0,9978	77	350,15	0,4189	0,9735	205	478,15	17,243	0,8588
23	296,15	0,02808	0,9976	78	351,15	0,4365	0,9729	210	483,15	19,077	0,8528
24	297,15	0,02982	0,9974	79	352,15	0,4547	0,9723	215	488,15	21,060	0,8467
25	298,15	0,03166	0,9971	80	353,15	0,4736	0,9716	220	493,15	23,198	0,8403
26	299,15	0,03360	0,9968	81	354,15	0,4931	0,9710	225	498,15	25,501	0,8339
27	300,15	0,03564	0,9966	82	355,15	0,5133	0,9704	230	503,15	27,976	0,8273
28	301,15	0,03778	0,9963	83	356,15	0,5342	0,9697	235	508,15	30,632	0,8205
29	302,15	0,04004	0,9960	84	357,15	0,5557	0,9691	240	513,15	33,478	0,8136
30	303,15	0,04241	0,9957	85	358,15	0,5780	0,9684	245	518,15	36,523	0,8065
31	304,15	0,04491	0,9954	86	359,15	0,6011	0,9678	250	523,15	39,776	0,7992
32	305,15	0,04753	0,9951	87	360,15	0,6249	0,9671	255	528,15	43,246	0,7916
33	306,15	0,05029	0,9947	88	361,15	0,6495	0,9665	260	533,15	46,943	0,7839
34	307,15	0,05318	0,9944	89	362,15	0,6749	0,9658	265	538,15	50,877	0,7759
35	308,15	0,05622	0,9940	90	363,15	0,7011	0,9652	270	543,15	55,058	0,7678
36	309,15	0,05940	0,9937	91	364,15	0,7281	0,9644	275	548,15	59,496	0,7593
37	310,15	0,06274	0,9933	92	365,15	0,7561	0,9638	280	553,15	64,202	0,7505
38	311,15	0,06624	0,9930	93	366,15	0,7849	0,9630	285	558,15	69,186	0,7415
39	312,15	0,06991	0,9927	94	367,15	0,8146	0,9624	290	563,15	74,461	0,7321
40	313,15	0,07375	0,9923	95	368,15	0,8453	0,9616	295	568,15	80,037	0,7223
41	314,15	0,07777	0,9919	96	369,15	0,8769	0,9610	300	573,15	85,927	0,7122
42	315,15	0,08198	0,9915	97	370,15	0,9094	0,9602	305	578,15	92,144	0,7017
43	316,15	0,09639	0,9911	98	371,15	0,9430	0,9596	310	583,15	98,70	0,6906
44	317,15	0,09100	0,9907	99	372,15	0,9776	0,9586	315	588,15	105,61	0,6791
45	318,15	0,09582	0,9902	100	373,15	1,0133	0,9581	320	593,15	112,89	0,6669
46	319,15	0,10086	0,9898	102	375,15	1,0878	0,9567	325	598,15	120,56	0,6541
47	320,15	0,10612	0,9894	104	377,15	1,1668	0,9552	330	603,15	128,63	0,6404
48	321,15	0,11162	0,9889	106	379,15	1,2504	0,9537	340	613,15	146,05	0,6102
49	322,15	0,11736	0,9884	108	381,15	1,3390	0,9522	350	623,15	165,35	0,5743
50	323,15	0,12335	0,9880	110	383,15	1,4327	0,9507	360	633,15	186,75	0,5275
51	324,15	0,12961	0,9876	112	385,15	1,5316	0,9491	370	643,15	210,54	0,4518
52	325,15	0,13613	0,9871	114	387,15	1,6362	0,9476	374,15	647,30	221,20	0,3154
53	326,15	0,14293	0,9862	116	389,15	1,7465	0,9460				
54	327,15	0,15002	0,9862	118	391,15	1,8628	0,9445				

G-at_nps_h_a_sc

TABLE OF FLOW RESISTANCE IN 100 m OF STRAIGHT CAST IRON PIPELINE (HAZEN-WILLIAMS FORMULA C=100)

FLOW RATE		NOMINAL DIAMETER in mm and INCHES																	
m ³ /h	l/min	15	20	25	32	40	50	65	80	100	125	150	175	200	250	300	350	400	
		1/2"	3/4"	1"	1 1/4"	1 1/2"	2	2 1/2"	3"	4"	5"	6"	7"	8"	10"	12"	14"	16"	
0,6	10	v 0,94	v 0,53	v 0,34	v 0,21	v 0,13													
		hr 16	hr 3,94	hr 1,33	hr 0,40	hr 0,13													
0,9	15	v 1,42	v 0,80	v 0,51	v 0,31	v 0,20													
		hr 33,9	hr 8,35	hr 2,82	hr 0,85	hr 0,29													
1,2	20	v 1,89	v 1,06	v 0,68	v 0,41	v 0,27	v 0,17												
		hr 57,7	hr 14,21	hr 4,79	hr 1,44	hr 0,49	hr 0,16												
1,5	25	v 2,36	v 1,33	v 0,85	v 0,52	v 0,33	v 0,21												
		hr 87,2	hr 21,5	hr 7,24	hr 2,18	hr 0,73	hr 0,25												
1,8	30	v 2,83	v 1,59	v 1,02	v 0,62	v 0,40	v 0,25												
		hr 122	hr 30,1	hr 10,1	hr 3,05	hr 1,03	hr 0,35												
2,1	35	v 3,30	v 1,86	v 1,19	v 0,73	v 0,46	v 0,30												
		hr 162	hr 40,0	hr 13,5	hr 4,06	hr 1,37	hr 0,46												
2,4	40	v 2,12	v 1,36	v 0,83	v 0,53	v 0,34	v 0,20												
		hr 51,2	hr 17,3	hr 5,19	hr 1,75	hr 0,59	hr 0,16												
3	50	v 2,65	v 1,70	v 1,04	v 0,66	v 0,42	v 0,25												
		hr 77,4	hr 26,1	hr 7,85	hr 2,65	hr 0,89	hr 0,25												
3,6	60	v 3,18	v 2,04	v 1,24	v 0,80	v 0,51	v 0,30												
		hr 108	hr 36,6	hr 11,0	hr 3,71	hr 1,25	hr 0,35												
4,2	70	v 3,72	v 2,38	v 1,45	v 0,93	v 0,59	v 0,35												
		hr 144	hr 48,7	hr 14,6	hr 4,93	hr 1,66	hr 0,46												
4,8	80	v 4,25	v 2,72	v 1,66	v 1,06	v 0,68	v 0,40												
		hr 185	hr 62,3	hr 18,7	hr 6,32	hr 2,13	hr 0,59												
5,4	90	v 3,06	v 1,87	v 1,19	v 0,76	v 0,45	v 0,30												
		hr 77,5	hr 23,3	hr 7,85	hr 2,65	hr 0,74	hr 0,27												
6	100	v 3,40	v 2,07	v 1,33	v 0,85	v 0,50	v 0,33												
		hr 94,1	hr 28,3	hr 9,54	hr 3,22	hr 0,90	hr 0,33												
7,5	125	v 4,25	v 2,59	v 1,66	v 1,06	v 0,63	v 0,41												
		hr 142	hr 42,8	hr 14,4	hr 4,86	hr 1,36	hr 0,49												
9	150	v 3,11	v 1,99	v 1,27	v 0,75	v 0,50	v 0,32												
		hr 59,9	hr 20,2	hr 6,82	hr 1,90	hr 0,69	hr 0,23												
10,5	175	v 3,63	v 2,32	v 1,49	v 0,88	v 0,58	v 0,37												
		hr 79,7	hr 26,9	hr 9,07	hr 2,53	hr 0,92	hr 0,31												
12	200	v 4,15	v 2,65	v 1,70	v 1,01	v 0,66	v 0,42												
		hr 102	hr 34,4	hr 11,6	hr 3,23	hr 1,18	hr 0,40												
15	250	v 5,18	v 3,32	v 2,12	v 1,26	v 0,83	v 0,53	v 0,34											
		hr 154	hr 52,0	hr 17,5	hr 4,89	hr 1,78	hr 0,60	hr 0,20											
18	300	v 3,98	v 2,55	v 1,51	v 1,00	v 0,64	v 0,41												
		hr 72,8	hr 24,6	hr 6,85	hr 2,49	hr 0,84	hr 0,28												
24	400	v 5,31	v 3,40	v 2,01	v 1,33	v 0,85	v 0,54	v 0,38											
		hr 124	hr 41,8	hr 11,66	hr 4,24	hr 1,43	hr 0,48	hr 0,20											
30	500	v 6,63	v 4,25	v 2,51	v 1,66	v 1,06	v 0,68	v 0,47											
		hr 187	hr 63,2	hr 17,6	hr 6,41	hr 2,16	hr 0,73	hr 0,30											
36	600	v 5,10	v 3,02	v 1,99	v 1,27	v 0,82	v 0,57	v 0,42											
		hr 88,6	hr 24,7	hr 8,98	hr 3,03	hr 1,02	hr 0,42	hr 0,20											
42	700	v 5,94	v 3,52	v 2,32	v 1,49	v 0,95	v 0,66	v 0,49											
		hr 118	hr 32,8	hr 11,9	hr 4,03	hr 1,36	hr 0,56	hr 0,26											
48	800	v 6,79	v 4,02	v 2,65	v 1,70	v 1,09	v 0,75	v 0,55											
		hr 151	hr 42,0	hr 15,3	hr 5,16	hr 1,74	hr 0,72	hr 0,34											
54	900	v 7,64	v 4,52	v 2,99	v 1,91	v 1,22	v 0,85	v 0,62											
		hr 188	hr 52,3	hr 19,0	hr 6,41	hr 2,16	hr 0,89	hr 0,42											
60	1000	v 5,03	v 3,32	v 2,12	v 1,36	v 0,94	v 0,69	v 0,53											
		hr 63,5	hr 23,1	hr 7,79	hr 2,63	hr 1,08	hr 0,51	hr 0,27											
75	1250	v 6,28	v 4,15	v 2,65	v 1,70	v 1,18	v 0,87	v 0,66											
		hr 96,0	hr 34,9	hr 11,8	hr 3,97	hr 1,63	hr 0,77	hr 0,40											
90	1500	v 7,54	v 4,98	v 3,18	v 2,04	v 1,42	v 1,04	v 0,80											
		hr 134	hr 48,9	hr 16,5	hr 5,57	hr 2,29	hr 1,08	hr 0,56											
105	1750	v 8,79	v 5,81	v 3,72	v 2,38	v 1,65	v 1,21	v 0,93											
		hr 179	hr 65,1	hr 21,9	hr 7,40	hr 3,05	hr 1,44	hr 0,75											
120	2000	v 6,63	v 4,25	v 2,72	v 1,89	v 1,39	v 1,06	v 0,68											
		hr 83,3	hr 28,1	hr 9,48	hr 3,90	hr 1,84	hr 0,96	hr 0,32											
150	2500	v 8,29	v 5,31	v 3,40	v 2,36	v 1,73	v 1,33	v 0,85											
		hr 126	hr 42,5	hr 14,3	hr 5,89	hr 2,78	hr 1,45	hr 0,49											
180	3000	v 6,37	v 4,08	v 2,83	v 2,08	v 1,59	v 1,02	v 0,71											
		hr 59,5	hr 20,1	hr 8,26	hr 3,90	hr 2,03	hr 0,96	hr 0,28											
210	3500	v 7,43	v 4,76	v 3,30	v 2,43	v 1,86	v 1,19	v 0,83											
		hr 79,1	hr 26,7	hr 11,0	hr 5,18	hr 2,71	hr 0,91	hr 0,38											
240	4000	v 8,49	v 5,44	v 3,77	v 2,77	v 2,12	v 1,36	v 0,94											
		hr 101	hr 34,2	hr 14,1	hr 6,64	hr 3,46	hr 1,17	hr 0,48											
300	5000	v 6,79	v 4,72	v 3,47	v 2,65	v 2,05	v 1,70	v 1,18											
		hr 51,6	hr 21,2	hr 10,0	hr 5,23	hr 1,77	hr 0,73	hr 0,27											
360	6000	v 8,15	v 5,66	v 4,16	v 3,18	v 2,47	v 1,42	v 1,02											
		hr 72,3	hr 29,8	hr 14,1	hr 7,33	hr 2,47	hr 1,02	hr 0,34											
420	7000	v 6,61	v 4,85	v 3,72	v 2,83	v 2,16	v 1,65	v 1,21											
		hr 39,6	hr 18,7	hr 9,75	hr 3,29	hr 1,35	hr 0,85	hr 0,32											
480	8000	v 7,55	v 5,55	v 4,25															

FLOW RESISTANCE

TABLE OF FLOW RESISTANCE IN BENDS, VALVES AND GATES

The flow resistance is calculated using the equivalent pipeline length method according to the table below:

ACCESSORY TYPE	DN											
	25	32	40	50	65	80	100	125	150	200	250	300
	Equivalent pipeline length (m)											
45° bend	0,2	0,2	0,4	0,4	0,6	0,6	0,9	1,1	1,5	1,9	2,4	2,8
90° bend	0,4	0,6	0,9	1,1	1,3	1,5	2,1	2,6	3,0	3,9	4,7	5,8
90° smooth bend	0,4	0,4	0,4	0,6	0,9	1,1	1,3	1,7	1,9	2,8	3,4	3,9
Union tee or cross	1,1	1,3	1,7	2,1	2,6	3,2	4,3	5,3	6,4	7,5	10,7	12,8
Gate	-	-	-	0,2	0,2	0,2	0,4	0,4	0,6	0,9	1,1	1,3
Non return valve	1,1	1,5	1,9	2,4	3,0	3,4	4,7	5,9	7,4	9,6	11,8	13,9

G-a-pcv_a_th

The table is valid for the Hazen Williams coefficient $C = 100$ (cast iron pipework). For steel pipework, multiply the values by 1.41. For stainless steel, copper and coated cast iron pipework, multiply the values by 1.85.

When the **equivalent pipeline length** has been determined, the flow resistance is obtained from the table of flow resistance.

The values given are guideline values which are bound to vary slightly according to the model, especially for gate valves and non-return valves, for which it is a good idea to check the values supplied by the manufacturers.

VOLUMETRIC CAPACITY

Litres per minute l/min	Cubic metres per hour m ³ /h	Cubic feet per hour ft ³ /h	Cubic feet per minute ft ³ /min	Imp. gal. per minute Imp. gal./min	US gal. per minute Us gal./min
1,000	0,0600	2,1189	0,0353	0,2200	0,2642
16,6667	1,0000	35,3147	0,5886	3,6662	4,4029
0,4719	0,0283	1,0000	0,0167	0,1038	0,1247
28,3168	1,6990	60,0000	1,0000	6,2288	7,4805
4,5461	0,2728	9,6326	0,1605	1,0000	1,2009
3,7854	0,2271	8,0208	0,1337	0,8327	1,0000

PRESSURE AND HEAD

Newton per square metre N/m ²	kilo Pascal kPa	bar bar	Pound force per square inch psi	metre of water m H ₂ O	millimetre of mercury mm Hg
1,0000	0,0010	1 x 10 ⁻⁵	1.45 x 10 ⁻⁴	1.02 x 10 ⁻⁴	0,0075
1000,0000	1,0000	0,0100	0,1450	0,1020	7,5006
1 x 10 ⁵	100,0000	1,0000	14,5038	10,1972	750,0638
6894,7570	6,8948	0,0689	1,0000	0,7031	51,7151
9806,6500	9,8067	0,0981	1,4223	1,0000	73,5561
133,3220	0,1333	0,0013	0,0193	0,0136	1,0000

LENGTH

millimetre mm	centimetre cm	metre m	inch in	foot ft	yard yd
1,0000	0,1000	0,0010	0,0394	0,0033	0,0011
10,0000	1,0000	0,0100	0,3937	0,0328	0,0109
1000,0000	100,0000	1,0000	39,3701	3,2808	1,0936
25,4000	2,5400	0,0254	1,0000	0,0833	0,0278
304,8000	30,4800	0,3048	12,0000	1,0000	0,3333
914,4000	91,4400	0,9144	36,0000	3,0000	1,0000

VOLUME

cubic metre m ³	litre litro	millilitre ml	imp. Gallon imp. gal.	US gallon US gal.	cubic foot ft ³
1,0000	1000,0000	1 x 10 ⁶	219,9694	264,1720	35,3147
0,0010	1,0000	1000,0000	0,2200	0,2642	0,0353
1 x 10 ⁻⁶	0,0010	1,0000	2.2 x 10 ⁻⁴	2.642 x 10 ⁻⁴	3.53 x 10 ⁻⁵
0,0045	4,5461	4546,0870	1,0000	1,2009	0,1605
0,0038	3,7854	3785,4120	0,8327	1,0000	0,1337
0,0283	28,3168	28316,8466	6,2288	7,4805	1,0000

G-at_pp-en_a_sc

FURTHER PRODUCT SELECTION AND DOCUMENTATION

Xylect

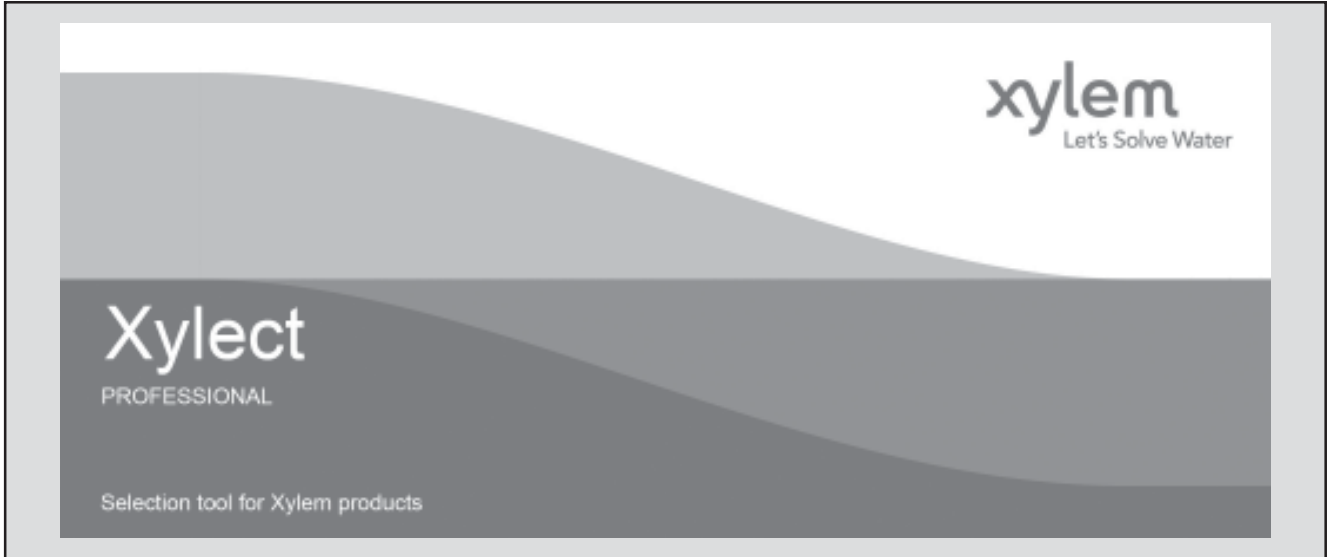

Xylect is pump solution selection software with an extensive online database of product information across the entire Lowara, and Vogel range of pumps and related products, with multiple search options and helpful project management facilities. The system holds up-to-date product information on thousands of products and accessories.

The possibility to search by applications and the detailed information output given makes it easy to make the optimal selection without having detailed knowledge about the Lowara and Vogel products.

The search can be made by:

- Application
- Product type
- Duty point

Xylect gives a detailed output:

- List with search results
- Performance curves (flow, head, power, efficiency, NPSH)
- Motor data
- Dimensional drawings
- Options
- Data sheet printouts
- Document downloads incl dxf files

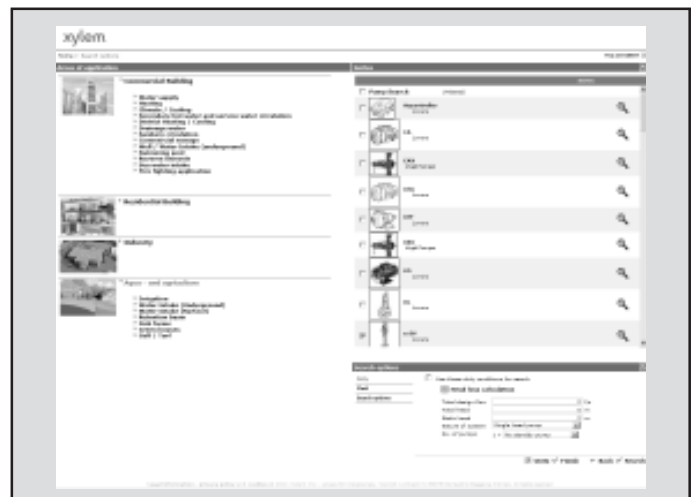

The search by application guides users not familiar with the product range to the right choice.

FURTHER PRODUCT SELECTION AND DOCUMENTATION

Xylect

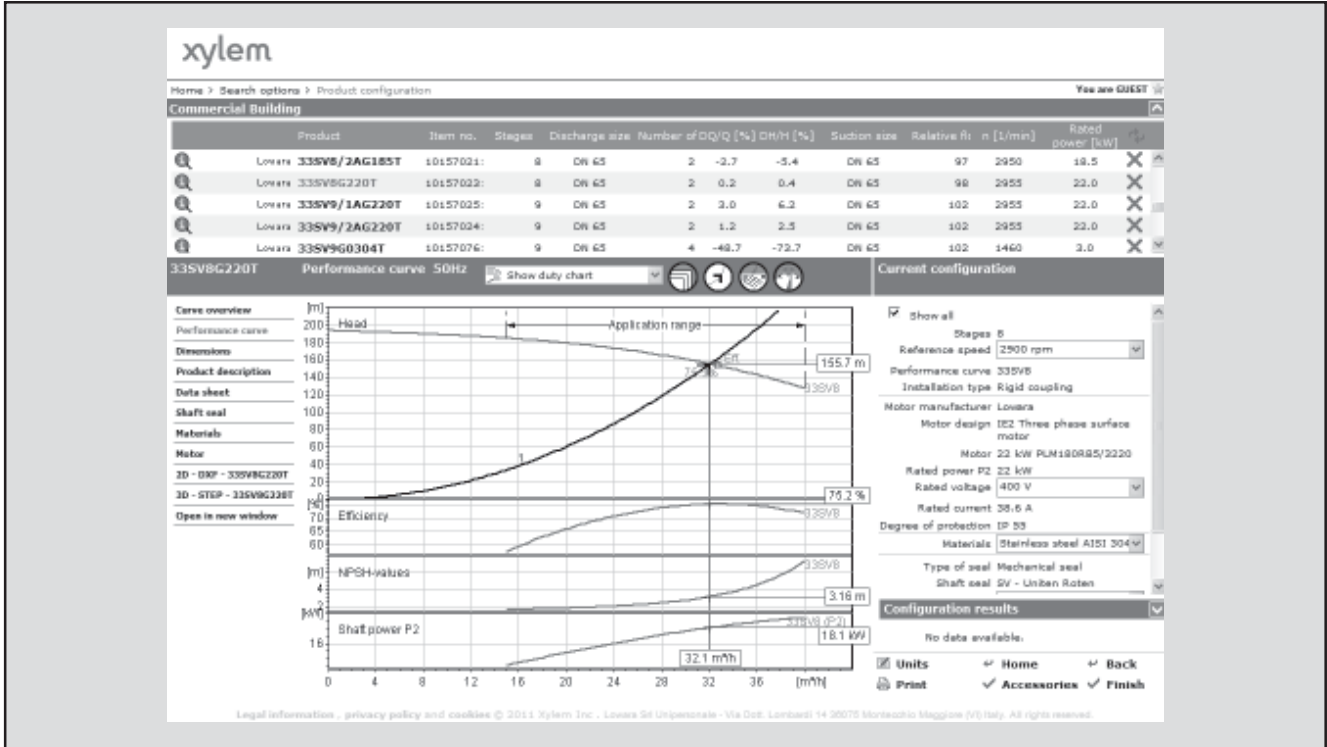

The detailed output makes it easy to select the optimal pump from the given alternatives.

The best way to work with Xylect is to create a personal account. This makes it possible to:

- Set own standard units
- Create and save projects
- Share projects with other Xylect users

Every user have a My Xylect space, where all projects are saved.

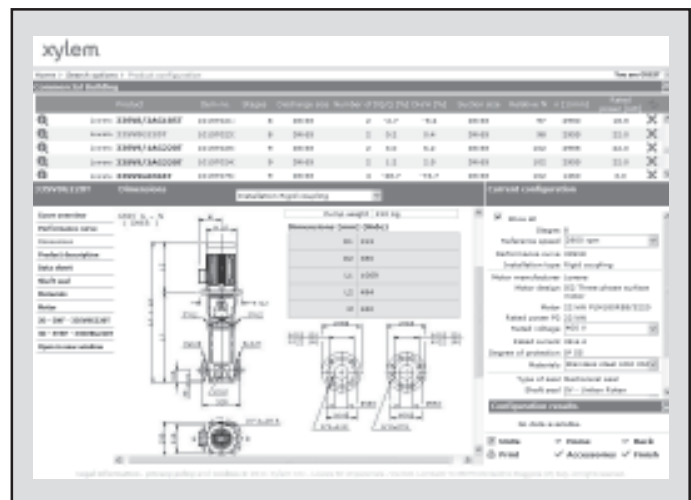

Dimensional drawings appear on the screen and can be downloaded in dxf format.

LENNTECH

info@lennotech.com Tel. +31-152-610-900
www.lennotech.com Fax. +31-152-616-289

Xylem |'zīləm|

- 1) The tissue in plants that brings water upward from the roots;
- 2) a leading global water technology company.

We're 12,000 people unified in a common purpose: creating innovative solutions to meet our world's water needs. Developing new technologies that will improve the way water is used, conserved, and re-used in the future is central to our work. We move, treat, analyze, and return water to the environment, and we help people use water efficiently, in their homes, buildings, factories and farms. In more than 150 countries, we have strong, long-standing relationships with customers who know us for our powerful combination of leading product brands and applications expertise, backed by a legacy of innovation.

LENNTECH

info@lennotech.com Tel. +31-152-610-900

www.lennotech.com Fax. +31-152-616-289

 **LOWARA**
a xylem brand

