

V5016A FLANGED LINEAR VALVE PN16

PRODUCT DATA



GENERAL

These single-seated valves are suitable for use in conjunction with the modulating control of hot / chilled water or steam in closed heating, ventilating, and air conditioning systems. They are designed especially for use in high differential pressure applications (e.g. district heating) and can be operated by linear actuators ML6420/ML6425, ML7420/ML7425, or ML6421/ML7421 or by pneumatic actuators MP953.

FEATURES

- Pressure-balanced plug
- Nodular iron body with flanged end connections
- Low seat leakage rate
- Metal-to-metal seating for long life span
- Self-adjusting packing
- Accurate positioning to ensure state-of-the-art temperature control
- Easy mounting of direct-coupled electric and pneumatic actuators
- Approved according to DIN EN 14597 in DN15...80 in combination with ML6425/ML7425

SPECIFICATIONS

Action	Stem down to close
Nominal pressure rating	PN16
Flow characteristic	Equal percentage
Rangeability	50:1
Leakage rate	≤0.05% of k_{VS} (DN15...80) ≤0.1% of k_{VS} (DN100...150)
Stroke	20 mm (DN15...80) 38 mm (DN100...150)
Valve body	
End connections	Flanged per ISO 7005-2
Material	Nodular iron (GGG40.3)
Dimensions	See Fig. 1 on page 3
Trim	
Seat	Stainless steel
Stem	Stainless steel
Plug	Stainless steel, skirt-guided
Packing	Spring-loaded PTFE cone rings
Medium temperature and pressure	2...180 °C (max. 1600 kPa)
Max. temp. differential	60 K (alternating hot/coldwater)
Medium	water, water-glycol (max. 50%), steam

SIZES AND FLOW CAPACITIES

order number	valve size	k _{vs}
V5016A1010	DN15	0.40
V5016A1028	DN15	0.63
V5016A1036	DN15	1.0
V5016A1044	DN15	1.6
V5016A1051	DN15	2.5
V5016A1069	DN15	4.0
V5016A1077	DN20	6.3
V5016A1085	DN25	10.0
V5016A1093	DN32	16.0
V5016A1101	DN40	25.0
V5016A1119	DN50	40.0
V5016A1127	DN65	63.0
V5016A1135	DN80	100.0
V5016A1143	DN100	160.0
V5016A1150	DN125	250.0
V5016A1168	DN150	360.0

INSTALLATION

- Water should meet VDI 2035 requirements.
- Do not install valve with stem below the horizontal.
- Fluid flow must correspond with the arrow direction on the valve body.
- The installation of a strainer is strongly recommended.

REPAIR PACKING KIT

Part No.: R43176755004 (DN15...80)
R43176755005 (DN100...150)

ACTUATORS

Electric Actuators

600 N (20 mm)	600 N (20 mm), spring return	1800 N (38 mm)
ML6420A	ML6425A,B	ML6421B
ML7420A	ML7425A,B	ML7421B

Pneumatic Actuators

actuator		stroke	acting		positioner
model	size		direct	reverse	
MP953A	5", 8"	20 mm	X		yes
	13"	38 mm			
MP953B	7"	20 mm		X	
MP953C	5", 8"	20 mm	X		no
	13"	38 mm			
MP953D	7"	20 mm		X	

CLOSE-OFF PRESSURE RATINGS (in kPa)

Electric Actuators

actuator			valve size										
model	stroke	force	DN15	DN20	DN25	DN32	DN40	DN50	DN65	DN80	DN100	DN125	DN150
ML6420A, ML6425A,B, ML7420A, ML7425A,B	20 mm	600 N	1600	1600	1600	1600	1600	1600	1600	1600	--	--	--
ML6421B, ML6421B	38 mm	1800 N	--	--	--	--	--	--	--	--	1600	1600	1600

Pneumatic Actuators

actuator			valve size										
model	spring range	air pressure	DN15	DN20	DN25	DN32	DN40	DN50	DN65	DN80	DN100	DN125	DN150
MP953A,C (5")	28...77 kPa (4...11 psi)	115 kPa	1600	1600	1600	1600	1600	1200	--	--	--	--	--
MP953A,C (8")	28...77 kPa (4...11 psi)	115 kPa	1600	1600	1600	1600	1600	1600	1600	1600	--	--	--
MP953B,D (7")	55...90 kPa (8...13 psi)	0 kPa	1600	1600	1600	1600	1600	1600	1600	1600	--	--	--
MP953A,C (13")	28...77 kPa (4...11 psi)	115 kPa	--	--	--	--	--	--	--	--	1600	1600	1600

DIMENSIONS

Valve

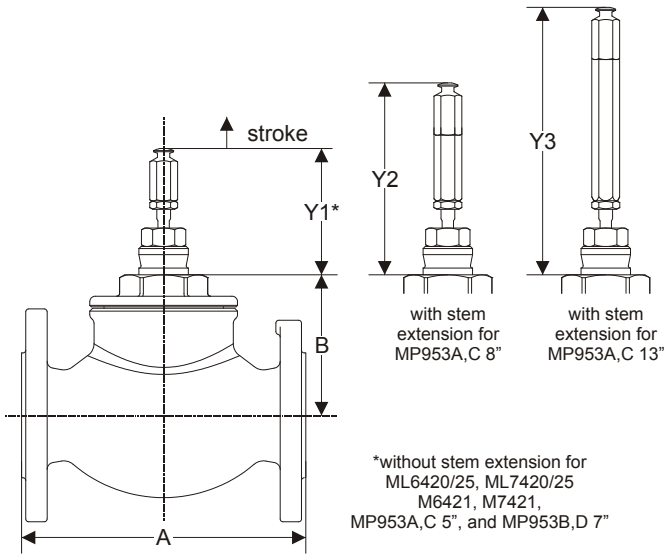

valve size	A	B	Y ₁ *	Y ₂ *	Y ₃ *
DN15	130	95	89	133	--
DN20	150				
DN25	160				
DN32	180	99			
DN40	200				
DN50	230	101			
DN65	290	106			
DN80	310	150	133	--	190
DN100	350				
DN125	400	156			
DN150	480	157			

* = Adjustment dimension. Valve in closed position.

Fig. 1. V5016A with stem extensions (dimensions in mm)

Electric Actuators

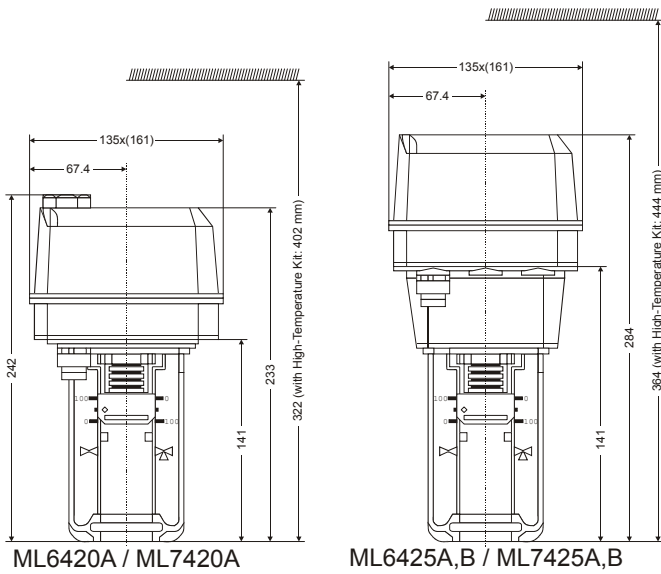

ML6420A / ML7420A

ML6425A,B / ML7425A,B

Fig. 2. ML6420A / ML7420A and ML6425A,B / ML7425A,B

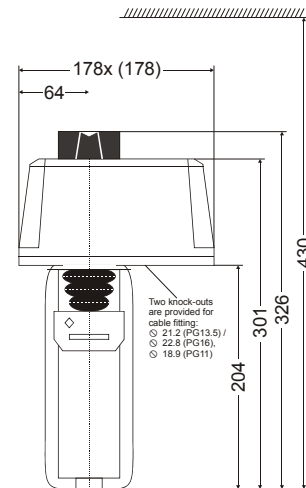

Fig. 3. ML6421B / ML7421B (dimensions in mm)

Pneumatic Actuators

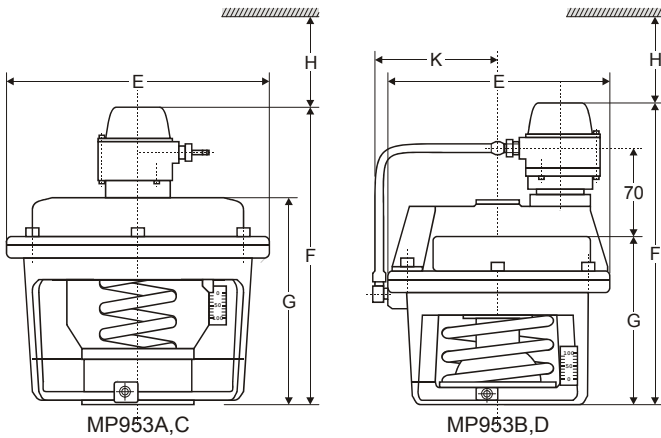

Fig. 4. MP953A,C / MP953B,D (dimensions in mm)

Model	ØE	F	G	H	K
MP953A, 5"	130	192	--	120	--
MP953C, 5"		-	120		
MP953A, 8"	210	237	--	140	--
MP953C, 8"		--	165		
MP953A, 13"	343	327	--	200	--
MP953C, 13"		--	255		
MP953B, 7"	180	242	--	120	107
MP953D, 7"		--	137		--

NOTE: V5016A valves in combination with the following actuators are approved according to DIN EN 14597:

Actuator O.S. No.	DIN Registration No.
ML6425A3006 ML6425A3014 ML7425A6008	1F139/08

Honeywell

Manufactured for and on behalf of the Environmental and Combustion Controls Division of Honeywell Technologies Sàrl, Rolle, Z.A. La Pièce 16, Switzerland by its Authorized Representative:

Automation and Control Solutions

Honeywell GmbH
Böblinger Strasse 17
71101 Schönaich
Germany

Phone: (49) 7031 63701

Fax: (49) 7031 637493

<http://ecc.emea.honeywell.com>

Subject to change without notice. Printed in Germany

EN0B-0440GE51 R0413