



DCV1 Disc Check Valve

Description

The DCV1 disc check valve is of the wafer pattern designed to be sandwiched between flanges. It is suitable for use on a wide range of fluids for applications in process lines, hot water systems, steam and condensate systems etc. Face-to-face dimensions conform to EN 558 part 1, series 49.

As standard it will be supplied with a metal-to-metal seat for use on steam applications. Where it is being used on oil, air, gas and water applications, alternative seat material is available - see 'Optional extras'.

Note: Wafer check valves are not suitable for use where heavily pulsating flow exists, such as close to a compressor

Optional extras

Heavy duty springs

(700 mbar opening pressure, up to DN65) for boiler feed applications.

Viton soft seats for oil, air and gas applications.

EPDM soft seats for water applications.

Standards

This product fully complies with the requirements of the Pressure Equipment Directive (PED).

Standard shut-off

Standard valves conform to EN 12266-1 rate E.

Valves conforming to EN 12266-1 rate D are available on request. Soft seated versions meet EN 12266-1 rate A, providing a differential pressure exists.

Certification

This product is available with a manufacturers Typical Test Report.

Note: All certification/inspection requirements must be stated at the time of order placement.

Sizes and pipe connections

DN15, DN20, DN25, DN32, DN40, DN50, DN65, DN80 and DN100.

Suitable for installation between BS 10 Tables 'E' and 'H', EN 1092 PN6, PN10, PN16, PN25, PN40; JIS 5, JIS 10, JIS 16, and JIS 20 flanges with the following exceptions:

Note 1: DN40, DN50, DN80 and DN100 - will not fit between JIS 5 flanges.

Note 2: DN65 and DN80 - will not fit between BS 10 'E' flanges.

Operation

Disc check valves are opened by the pressure of the fluid and closed by the spring as soon as the flow ceases and before the reverse flow occurs.

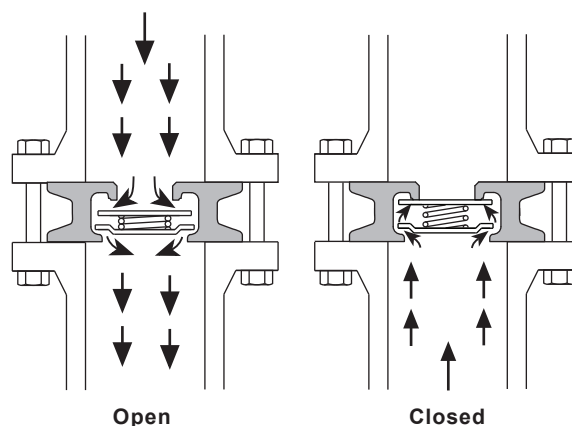
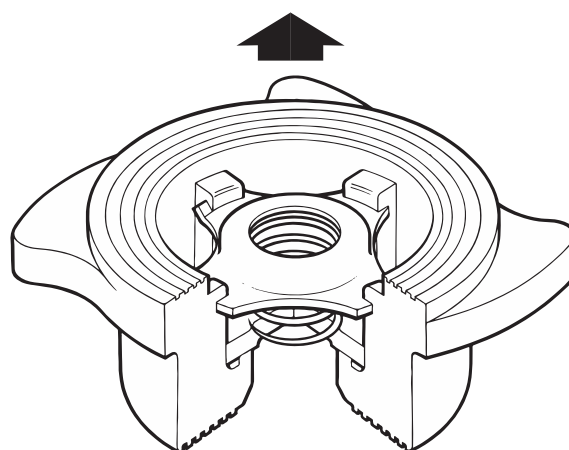

Materials

No.Part	Material	
1 Body	Bronze	WS 2.1050
2 Disc	Austenitic stainless steel	ASTM A276 316
3 Spring retainer	Austenitic stainless steel	BS 1449 316 S11
Standard spring	Austenitic stainless steel	BS 2056 316 S42
4 Heavy duty spring	Austenitic stainless steel	BS 2056 316 S42

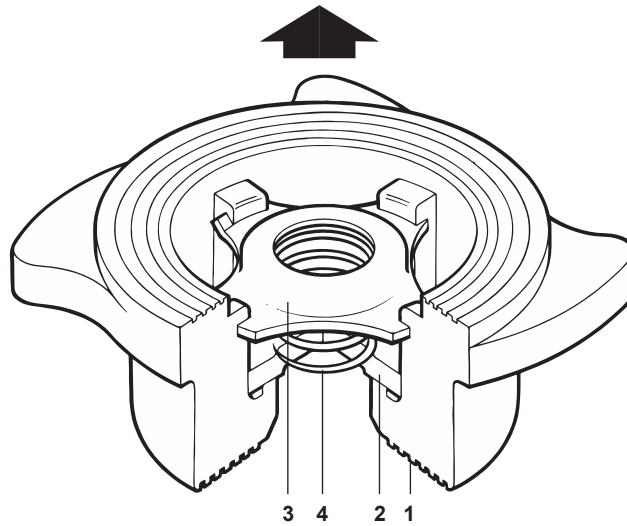

Pressure/temperature limits

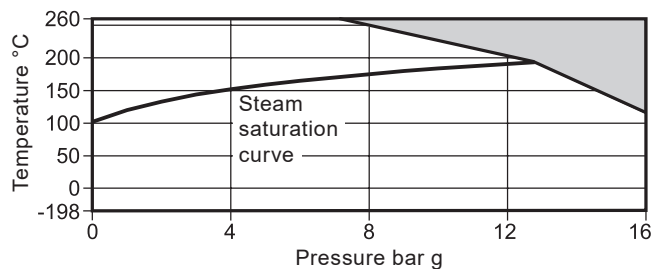

Please note: The figures displayed are only relevant when a metal-to-metal seat is used. If Viton or EPDM seats are used the product is restricted to the limits of the seat material chosen.

Body design conditions for saturated steam service		PN16
PMA	Maximum allowable pressure	16 bar g @ 120 °C
TMA	Maximum allowable temperature	260 °C @ 7 bar g
Minimum allowable temperature		-198 °C
PMO	Maximum operating pressure for saturated steam service	13.2 bar g @ 196 °C
TMO	Maximum operating temperature	260 °C @ 7 bar g
Minimum operating temperature		-198 °C
Note: For lower operating temperatures consult Spirax Sarco		
Temperature limits	Viton seat	-25 °C to +205 °C
	EPDM seat	-40 °C to +120 °C
Designed for a maximum cold hydraulic test pressure of		24 bar g

Dimensions/weights (approximate) in mm and kg

Size	A	B	C	D	E	F	Weight
DN15	60.0	43	38	16.0	29.0	15	0.13
DN20	69.5	53	45	19.0	35.7	20	0.19
DN25	80.5	63	55	22.0	44.0	25	0.32
DN32	90.5	75	68	28.0	54.5	32	0.55
DN40	101.0	85	79	31.5	65.5	40	0.74
DN50	115.0	95	93	40.0	77.0	50	1.25
DN65	142.0	115	113	46.0	97.5	65	1.87
DN80	154.0	133	128	50.0	111.5	80	2.42
DN100	184.0	154	148	60.0	130.0	100	3.81

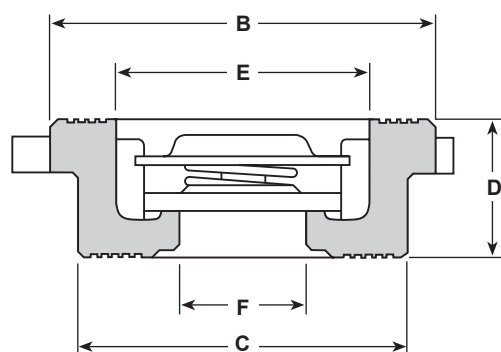
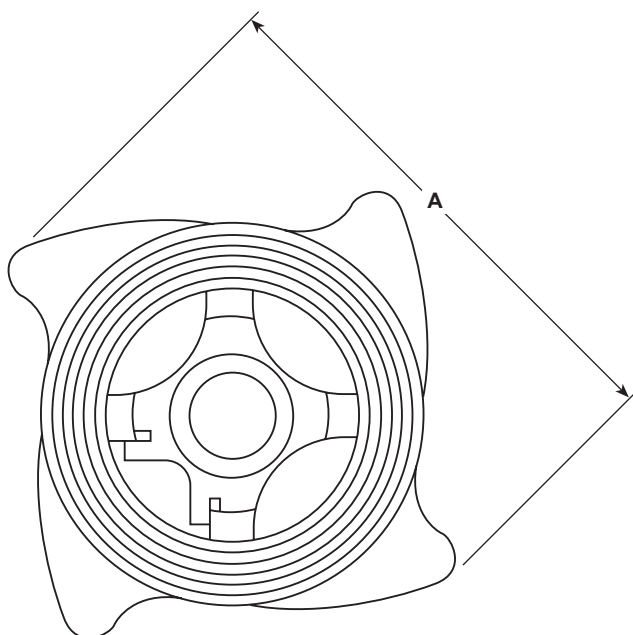

K_v values

DN	15	20	25	32	40	50	65	80	100
K _v	4.4	6.8	10.8	17	26	43	60	80	113

For conversion:

$$C_v \text{ (UK)} = K_v \times 0.963$$

$$C_v \text{ (US)} = K_v \times 1.156$$

Opening pressures in mbar

Differential pressures with zero flow for standard and high temperature springs.

→ Flow direction

DN	15	20	25	32	40	50	65	80	100
↑	25	25	25	27	28	29	30	31	33
→	22.5	22.5	22.5	23.5	24.5	24.5	25	25.5	26.5
↓	20	20	20	20	20	20	20	20	20

Where lowest opening pressures are required, valves without springs can be installed in vertical pipes with bottom-to-top flow.

Without spring

↑	2.5	2.5	2.5	3.5	4	4.5	5	5.5	6.5
---	-----	-----	-----	-----	---	-----	---	-----	-----

Heavy duty springs approximately 700 mbar

Pressure loss diagram

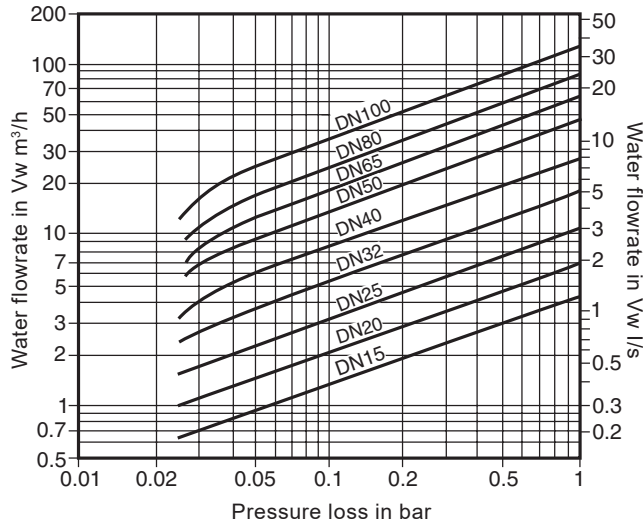

Pressure loss diagram with open valve at 20 °C. The values indicated are applicable to spring loaded valves with horizontal flow. With vertical flow, insignificant deviations occur only within the range of partial opening. The curves given in the chart are valid for water at 20 °C. To determine the pressure for other fluids the equivalent water volume flowrate must be calculated and used in the graph.

$$\dot{V}_w = \sqrt{\frac{\rho}{1000}} \times \dot{V}$$

Where: \dot{V}_w = Equivalent water volume flow in l/s or m³/h

ρ = Density of fluid kg/m³

\dot{V} = Volume of fluid l/s or m³/h

Pressure loss information for steam, compressed air and gases is available from Spirax Sarco.

How to order

Example: 1 off Spirax Sarco DN50, DCV1 bronze disc check valve for fitting between EN 1092 PN25 flanges.

Safety information, installation and maintenance

For full details see the Installation and Maintenance Instructions (IM-S19-04-EN-ISS1) supplied with the product.

DCV disc check valves must be fitted in accordance with the direction of flow arrow indicating correct fluid flow direction. When fitted with a spring they can be installed in any plane. When supplied without a spring they must be fitted in a vertical flow line with the flow from bottom-to-top.

The 'cam' design of the body allows the various flange types to be accommodated. The body is rotated to touch the flange joint bolts ensuring that the valve is centred in the pipeline.

*** Note:** Flanges, bolts (or studs), nuts and joint gaskets are to be provided by the installer. Disc check valves are non-maintainable (no spares are available). Disc check valves are not suitable for use where heavily pulsating flow exists, such as close to a compressor.

Various options are denoted by a marking on the valve body:

'W'	– Without spring	– Standard metal disc
'H'	– Heavy duty spring	– Standard metal disc
'V'	– Standard spring	– Viton soft faced disc
'E'	– Standard spring	– EPDM soft faced disc
'WV'	– Without spring	– Viton soft faced disc
'WE'	– Without spring	– EPDM soft faced disc
'HV'	– Heavy duty spring	– Viton soft faced disc
'HE'	– Heavy duty spring	– EPDM soft faced disc
'T'	– Valves tested to EN 12266-1 Rate D	

No identification indicates a standard spring with a metal disc.

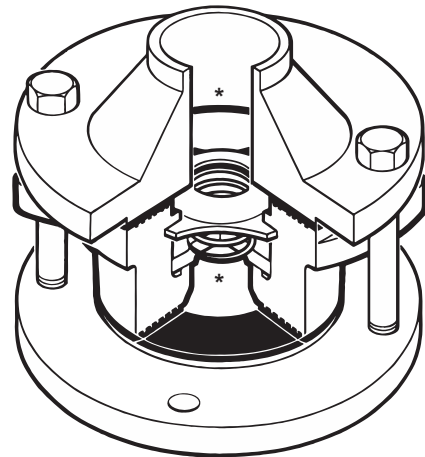

Disposal

If a product which contains a Viton component has been subjected to a temperature approaching 315 °C or higher, then it may have decomposed and formed hydrofluoric acid. Avoid skin contact and inhalation of any fumes as the acid will cause deep skin burns and damage to the respiratory system. Viton must be disposed of in a recognised manner as stated in the Installation and Maintenance Instructions (IM-S19-04-EN-ISS1). No other ecological hazard is anticipated with the disposal of this product providing due care is taken.