

CHECK VALVE TYPE RV



Type RV 10 with a crack device.

TECHNICAL DATA

Nominal diameter:	DN 40 – DN 300
Face-to-face:	EN 558-1 GR 48
Flange accommodation:	DIN 2501 PN10 / 16
Marking:	DIN EN 19
Tightness check:	EN 12266
Temperature range:	-10 °C to +90 °C
Body:	EN-GJL-250 (Grey Cast Iron)
Disc:	rubber coated, EPDM-KTW
Seal for top cover:	EPDM
Screws:	A2
Operating pressure:	max.16 bar, ≥ DN 200 10 bar
Coating:	powder coating RAL 5015, min. 200 µm

MATERIAL SPECIFICATION AND PARTS LIST

Pt.	Description	Material
1	Body	EN-GJL-250
2	Top cover	EN-GJK-250
3	Disc	EPDM-KTW on metal core
4	Discharging screw	Brass
5	Gasket/Sealing	Copper
6	O-Ring	EPDM

FEATURES

- Full passage
- Suitable for potable water and sewage
- Suitable for both horizontal and vertical installation position
- Low-resistance disc suspension
- Absolutely tight at 0,5 bar differential pressure
- Disc: rubber-coated with double-sided sealing surface
- Discharging screw replaceable against crack device

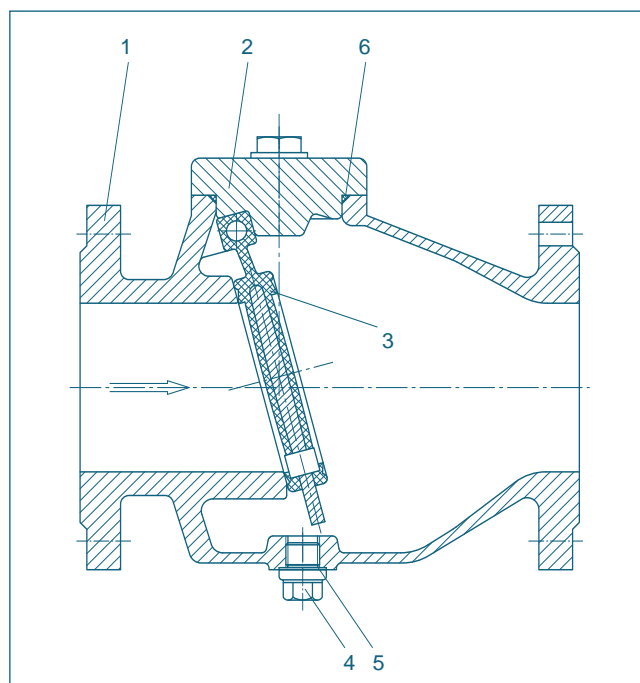

Type RV 20 with discharging screw.

CHECK VALVE TYPE RV

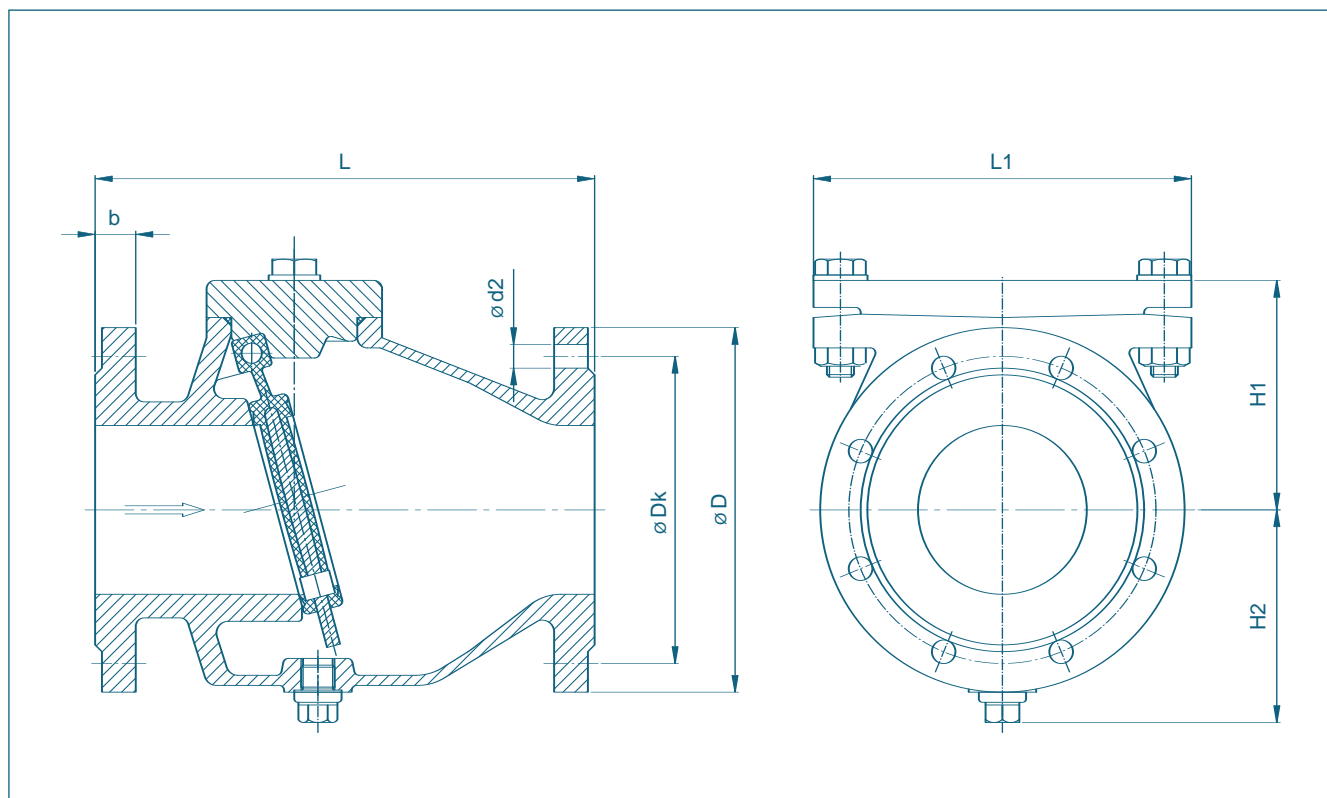

DN [mm]	Size [in]	Dimensions [mm]									Weight [kg]
		L1	H1	H2	L	D	Dk	n	d2	b	
40	1½	164	100	90	180	150	110	4	18	18	9,5
50	2	164	100	90	200	165	125	4	18	20	14,1
65	2½	186	111	98	240	185	145	4	18	20	16,0
80	3	200	125	105	260	200	160	8	18	22	24,0
100	4	225	140	125	300	220	180	8	18	24	29,0
125	5	304	175	157	350	250	210	8	18	26	40,5
150	6	360	205	172	400	285	240	8	22	26	55,0
200	8	400	251	205	500	340	295	8	22	30	101,0
250	10	464	290	230	600	405	350	12	22	32	146,0
300	12	504	312	255	700	455	400	12	22	32	251,0

Subject to change without notice.