

USERS MANUAL

Check valve

zCHE

FIG. 275, 277, 287, 288, 302

Edition: 07/2016

Date: 01.07.2016

CONTENTS

1. Product description
2. Requirement for maintenance staff
3. Transport and storage
4. Function
5. Application
6. Assembly
7. Maintenance
8. Service and repair
9. Reasons of operating disturbances and remedy
10. Valve service discontinuity
11. Warranty terms

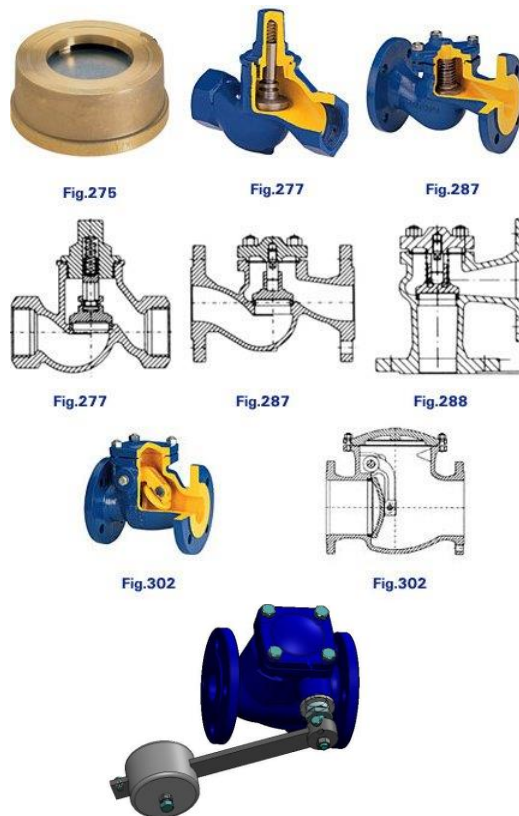

1. PRODUCT DESCRIPTION

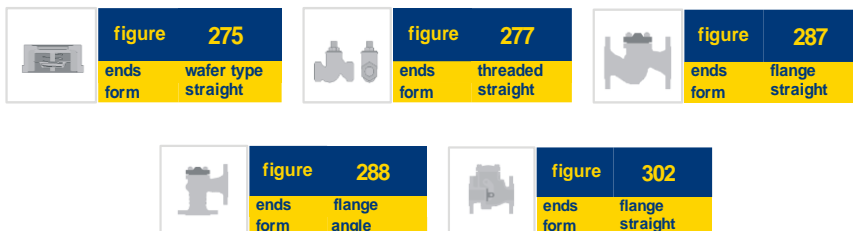

Check valves are provided with casted marking according to requirements of PN-EN19 standard. The marking facilitates technical identification and contains:

- diameter nominal DN (mm),
- pressure nominal PN (bar),
- body and bonnet material marking,
- arrow indicating medium flow direction,
- manufacturer marking,
- heat number,
- CE marking, for valves subjected 2014/68/UE directive. CE marking starts from DN32

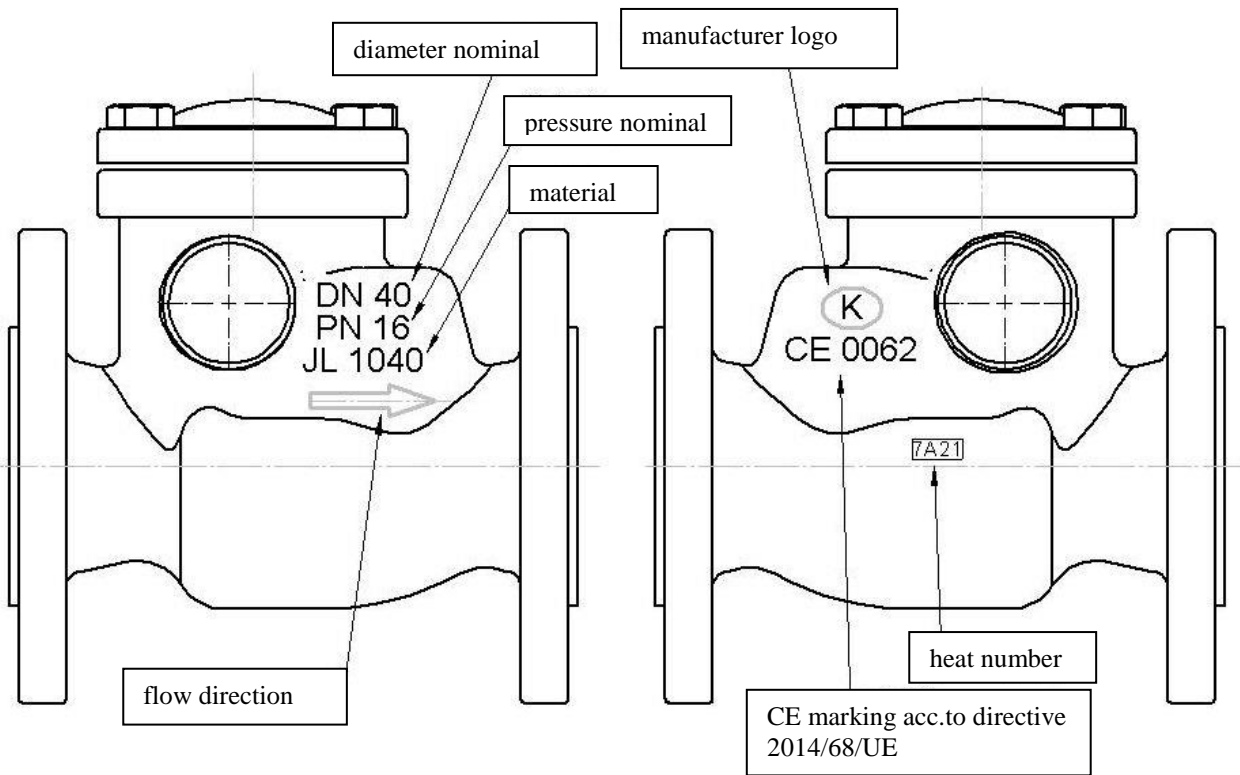

2. REQUIREMENTS FOR MAINTENANCE STAFF

The staff assigned to assembly, operating and maintenance tasks should be qualified to carry out such jobs. During valve operation heat parts of the valve, for example body or bonnet parts could cause burn. If necessary user should place protective shields and warning labels.

3. TRANSPORT AND STORAGE

Transport and storage should be carried out at temperature from -20° to 65°C , and valves should be protected against external forces influence and destruction of painting layer as well. The aim of painting layer is to protect the valves against rust during transport and storage. Valves should be kept at unpolluted rooms and they should be also protected against influence of atmospheric conditions. There should be applied drying agent or heating to damp rooms in order to prevent condensate formation.

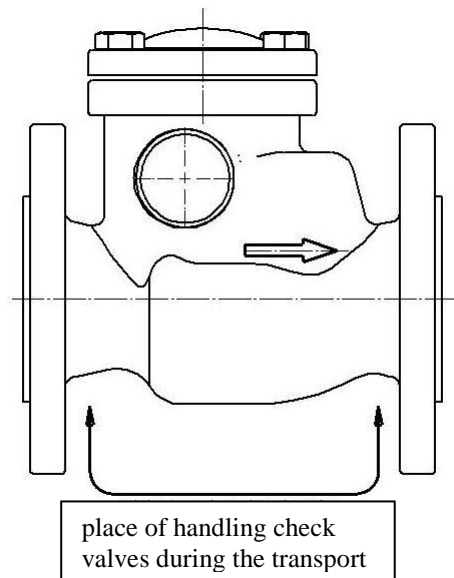
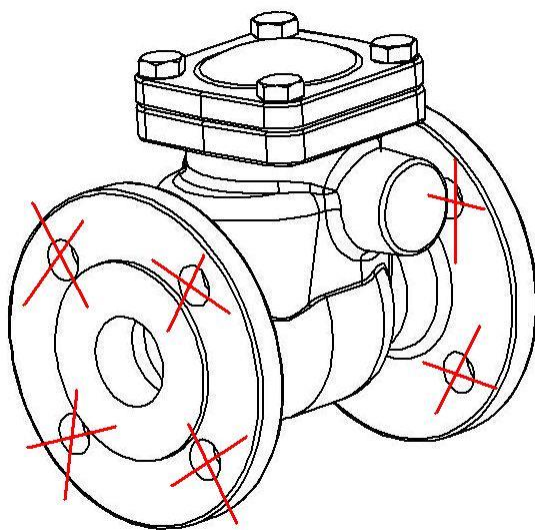

It is not allowed to fit lifting devices to connecting holes

4. FUNCTION

Check valves are designed for one direction flow of the medium and to protect against its back flow. Application range was mentioned at catalogue card. The kind of working medium makes some materials to be use or to be prohibited for use. Valves were designed for normal working conditions. In the case that working conditions exceed these requirements (for example for aggressive or abrasive medium) user should ask manufacturer before placing an order. When selecting the valve for specific medium, "List of Chemical Resistance" can be helpful. It can be found at manufacturer website near catalogue cards. Working pressure should be adapted to maximum medium temperature according to the table as below.

Check valve Fig. 275

Acc to EN 1092-2		Temperature [° C]		
Material	PN	from -10 up to 120	150	200
CuZn39Pb2	16	16 bar	16 bar	13,6 bar

Check valve Fig. 275

Acc to EN 1092-2		Temperature [° C]		
Material	PN	from 20 up to 100	200	300
G-X6CrNiMo 18 10	40	40 bar	35,8 bar	31,6 bar

Check valve Fig. 277

Acc to EN 1092-2		Temperature [° C]			
Material	PN	from -10 up to 120	150	180	200
EN-GJL250	16	16 bar	14,4 bar	13,4 bar	12,8 bar

Check valve Fig. 287, 288,302

Acc to EN 1092-2		Temperature [° C]						
Material	PN	from -10 up to 120	150	180	200	230	250	300
EN-GJL250	16	16 bar	14,4 bar	13,4 bar	12,8 bar	11,8 bar	11,2 bar	9,6 bar

Check valve Fig. 287, 288,302

Acc to EN 1092-2		Temperature [° C]						
Material	PN	from -10 up to 120	150	180	200	230	250	300
EN-GJL250	10	10 bar	9 bar	8,4 bar	8 bar	7,4 bar	7 bar	6 bar



Plant designer is responsible for valve selection suitable for working conditions.

5. APPLICATION

- fig. 275 for hot and cold water, glycol
- fig. 287 for steam and water
- fig. 302 for cold water, industrial technologies, power industry, heat industry, HVAC plants

6. ASSEMBLY

During the assembly of check valves following rules should be observed:

- to evaluate before an assembly if the valves were not damaged during the transport or storage
- to make sure that applied valves are suitable for working conditions and medium used in the plant
- to take off dust caps if the valves are provided with them

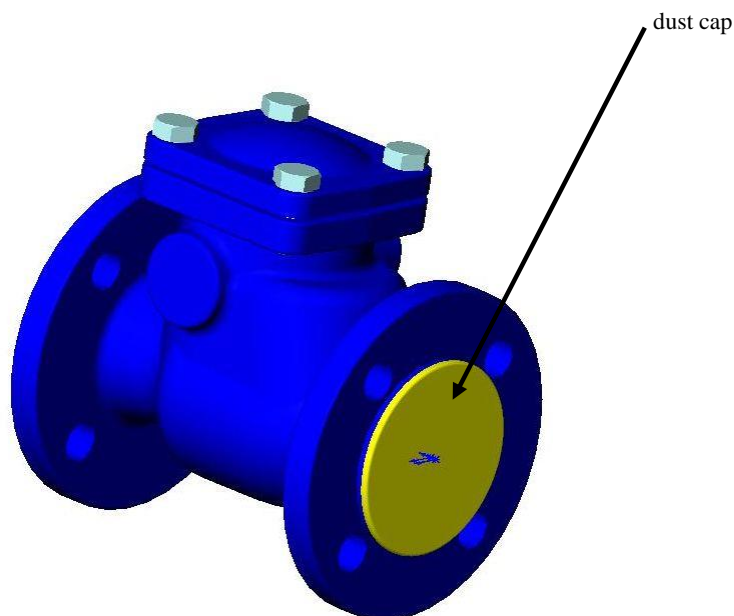

- swing check valves are provided with flap locking device in order to prevent the flap from moving during the transport, take it off from the valve body,
- check if the valve body is free of solid particles,
- steam pipelines should be fitted in such a way to avoid condensate collection
- protect the valves during welding jobs against splinters and used plastics against excessive temperature,,



Pipeline where the valves are fitted should be conducted and assembled in such a way that the valve body is not subjected to bending moment and stretching forces.

Bolted joints on the pipeline must not cause additional stress resulted from excessive tightening, and fastener materials must comply with working conditions of the plant.

- use expansion pipe joints in order to reduce influence of pipeline thermal expansion ,



To assembly the valve in such a way that flow direction comply with an arrow placed on the body.

- wafer type check valves Fig. 275 are assembled between pipeline connecting flanges provided with flat raised face, the connection is tighten by bolts. There is used return spring which enables to fit these valves at any position for horizontal and vertical pipelines as well. These valve are not recommended for use at pulsatory flow plants.

assembly way at the pipeline

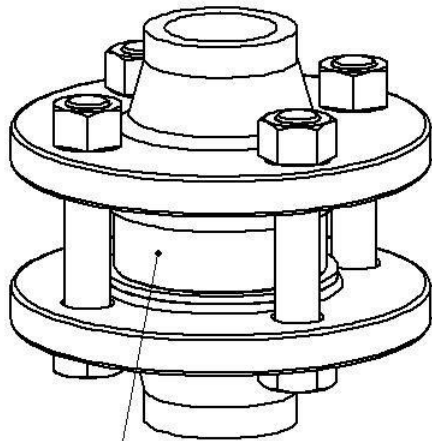

wafer type check valve

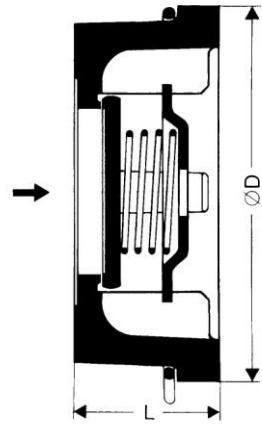

- swing check valves can be assembled at horizontal pipelines (with cover upwards) and vertical pipelines (medium flow must be upwards in this case); pay attention to keep flap rotation axis at horizontal position; valves with lever and counter weight should be assembled at horizontal pipelines only with cover upwards,

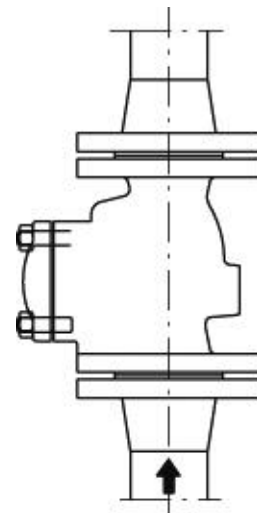
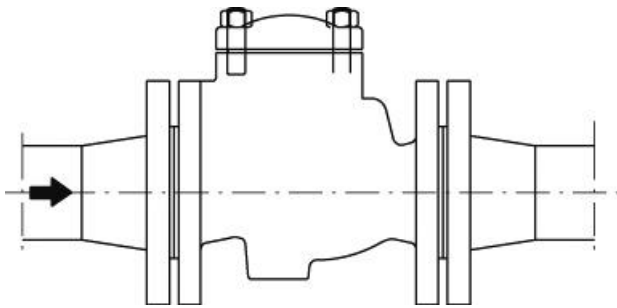

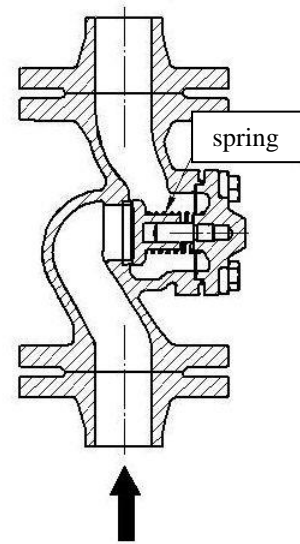
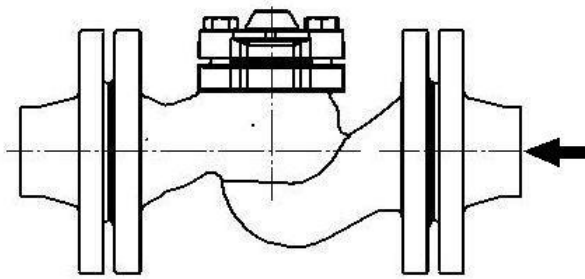

- lift type check valves Fig. 277, 287, 288 should be assembled at horizontal pipelines with cover upwards and in vertical pipelines on condition that valve with a spring will be used.
- before plant startup, especially after repairs carried out, flash out the pipeline
- strainer (wire mesh filter) installed before the valve increases certainty of its correct action

7. MAINTENANCE

During maintenance following rules should be observed :

- startup process – sudden changes of pressure and temperature should be avoided when starting the plant,
- valves work automatically and require no maintenance during operation
- valves Fig.302.11, 302.21, 302.16, 302.26 are provided with lever-counterweight device that aids shut-off movement and increase pressure on sealing surface in close position of the valve; weight position on the lever can be changed within lever length, it enables adjustment of pressure force on sealing surface,



In order to assure safety performance, each valve (especially rarely used) should be surveyed on regular basis. Inspection frequency should be laid down by user, but not less than one time per month.

8. SERVICE AND REPAIR



Before taking up any service jobs make sure that medium supply to the pipeline was cut off, pressure was decreased to ambient pressure, medium was removed from the pipeline and plant was cooled down.

- All service and repair jobs should be carried out by authorized staff using suitable tools and original spare parts.
- Before disassembly of complete valve from the pipeline or before service, the pipeline should be out of operation.
- During service and repair jobs personal health protectives in pursuance of existing threat should be used,
- After valve disassembly it is necessary to replace flange connection gaskets between valve and pipeline,
- Everytime when valve bonnet was disassembled sealing surface should be cleaned. During assembly it should be applied new gasket of the same type as previously used



Precautions should be taken when touching gasket between body and valve cover. The gasket contains stainless steel stripe that may cause injury,

- The bolts should be tighten evenly and crosswise by torque wrench

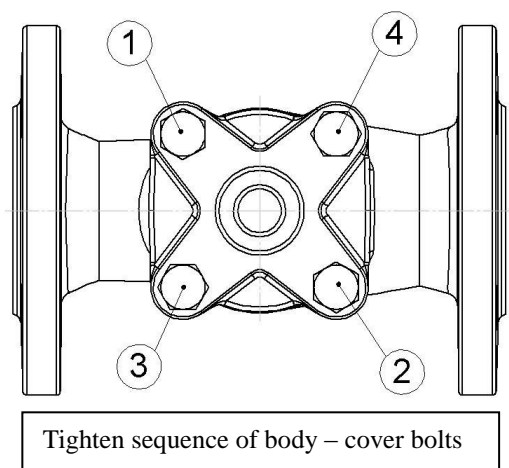

- Tighten torques

Screw	Torque
M8	15-20 Nm
M10	35-40 Nm
M12	65 – 70 Nm
M16	140 -150 Nm
M20	150-200 Nm
M24	350-400 Nm

- before valves re-assembly in the pipeline it is necessary to check valve operation and tightness of all connections. Tightness test should be carried out with water pressure of 1,5 nominal pressure of the valve.

9. REASONS OF OPERATING DISTURBANCES AND REMEDY

- When seeking of valve malfunction reasons safety rules should be strictly obeyed

Fault	Possible reason	Remedy
No flow	Flap locking device (Fig. 302) was not removed from the body	Remove flap locking device
	Flange dust caps were not removed	Remove dust caps on the flanges
Poor flow	Dirty filter before the valve	Clean or replace the screen
	Clogged pipeline	Check the pipeline
Leakage on the counter weight lever shaft	Too much loose on the gland	Tighten the gland untill tightness will be reached
	Damaged packing rings (Fig. 302.11 i 302.21)	Add packing rings and tighten the gland

	Damaged O-rings Fig.302.16 i 302.26	Replace O-rings
Difficult control of counter weight lever shaft	Gland packing tighten too much Fig. 302.11 i 302.21	Slightly slacken gland. Put attention to keep stuffing box tightness
	Dry shaft	Grease the shaft
Shaft leakage	Damaged O-rings Fig. 302.86	Replace O-rings
Seat leakage	Damaged seat, disc or flap	Replace the valve and contact supplier or manufacturer
	Medium polluted with solid particles	Clean the valve. Fit a strainer before the valve
	Wrong assembly of disc valve without spring Fig. 277, 287 i 288	Fit the valve properly or replace with valve with spring
	Damaged rubber sealing of the flap Fig. 302.06 , 302.16 i 302.26	Replace rubber sealing
Noisy valve operation	Heavy turbulent flow	Check the design once again, make necessary amendments, apply flow throttling
	Valve fitted too close the pump or after pipe elbow	
	Lack of expansion pipe joints or lack of straight pipelines to stabilize the flow before and after the valve	
	Valve size DN is not matched up with medium flow rate	Match up suitable valve size DN, apply flow throttling
Broken connecting flange	Bolts tighten unevenly	Replace the valve with new one

10. VALVE SERVICE DISCONTINUITY

All obsolete and dismantled valves must not be disposed with household waste. ZETKAMA valves are made of materials which can be re-used and should be delivered to designated recycling centres.

11. WARRANTY TERMS

- ZETKAMA grants quality warranty with assurance for proper operation of its products, providing that assembly of them is done according to the users manual and they are operated according to technical conditions and parameters described in ZETKAMA's catalogue cards. Warranty period is 18 months starting from assembly date, however not longer than 24 months from the sales date.

- warranty claim does not cover assembly of foreign parts and design changes done by user as well as natural wear.

- immediately after detection the user should inform ZETKAMA about hidden defects of the product

- a claim should be prepared in written form.

Address for correspondence :

ZETKAMA Sp. z o.o.
ul. 3 Maja 12
57-410 Ścinawka Średnia

Phone +48 74 86 52 111
Fax +48 74 86 52 101
Website: www.zetkama.com