

# Data sheet

## FVR, FVR-D Strainers

### Description

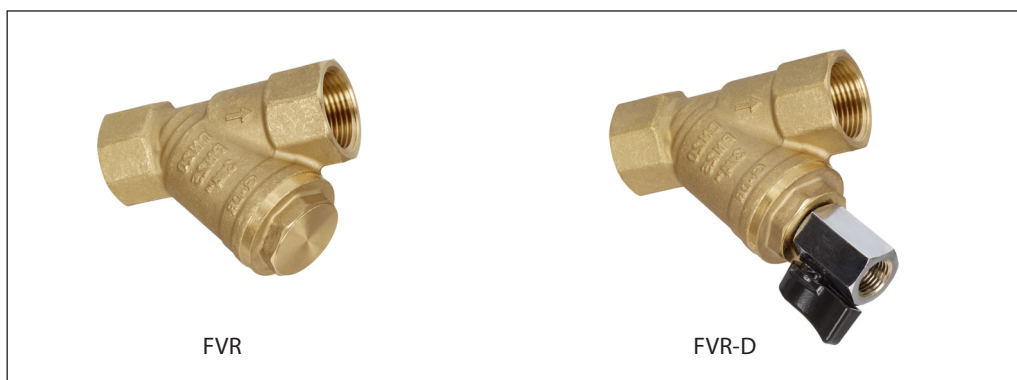

FV strainer is used in heating and hot-water service systems to protect the fittings. The strainer filter traps foreign matters in the pipe water like welding beads, swarf, sand, etc. FV must be fitted in the system flow to protect the fittings from external foreign matters. FV must also be fitted ahead of sensitive components like meters, pumps, control valves to protect against internal foreign matters.

#### Features:

- Replaceable filter
- Version with draining ball valve (FVR-D)

#### Main data:

- DN 10-50
- $k_{vs}$  3-36 m<sup>3</sup>/h
- PN 25
- Temperature: -10 ... 130 °C
- Medium: Circulation water / glycolic water up to 50 %
- Min. storage and transport temperature: -40 °C
- Threaded connection

### Ordering

Picture	DN (mm)	$k_{vs}$ (m <sup>3</sup> /h)	FVR Code No.	FVR-D Code No.
	10	3	065B8234	-
	15	4,5	065B8235	065B8241
	20	7,9	065B8236	065B8242
	25	11,2	065B8237	065B8243
	32	17	065B8238	065B8244
	40	24,5	065B8239	065B8245
	50	36	065B8240	065B8246

#### Spare parts - Screen

Picture	DN (mm)	FVR, FVR-D Code no.
	10	065B8247
	15	
	20	065B8248
	25	065B8249
	32	065B8250
	40	065B8251
	50	065B8252

#### Accessories - Ball valve

Picture	DN (mm)	FVR-D Code no.
	10	065B8254
	15	
	20	
	25	
	32	
	40	
	50	

Ordering

<b>Nominal diameter</b>	<b>DN</b>	<b>10</b>	<b>15</b>	<b>20</b>	<b>25</b>	<b>32</b>	<b>40</b>	<b>50</b>
Value <sub>kvs</sub>	m <sup>3</sup> /h	3	4,5	7,9	11,2	17	24,5	36
Nominal pressure	PN	25						
Medium	Circulation water, glycolic water up to 50%							
Medium pH	Min. 7, Max. 10							
Medium temperature	°C	0 ... 130						
Mesh size	µm	500						
Number of meshes	n/cm <sup>2</sup>	50						
Connection	Internal thread Rp							
<b>Materials</b>								
Body (strainer)	Dezincification free brass							
Plug (strainer)	Dezincification free brass							
Screen	Stainless steel							
O-ring	EPDM							
Body (ball valve)	Brass							

Applications

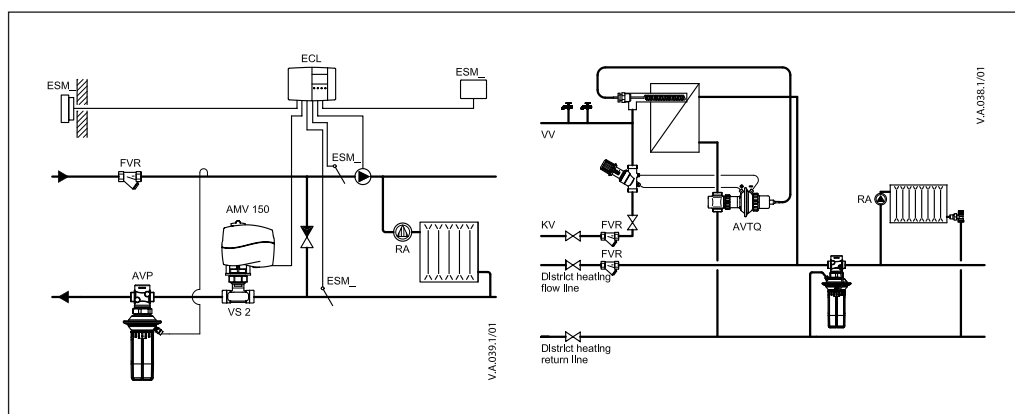

Installation positions

The medium flow direction must correspond to an arrow on the strainer body.

Strainers are to be installed in horizontal position with mesh bonnet directed downwards. Vertical position is also allowed (be aware - when medium flows upwards strainer retains all foreign particles but is not able to collect them).

Sufficient space to pull out the mesh for replacement and cleaning must be ensured.

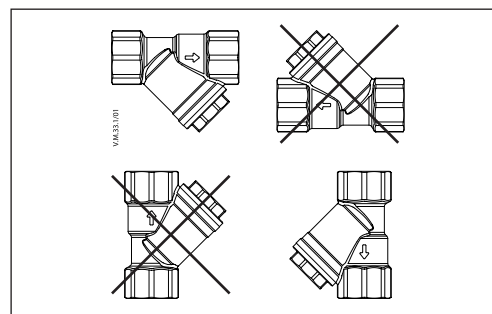

Pressure temperature diagram

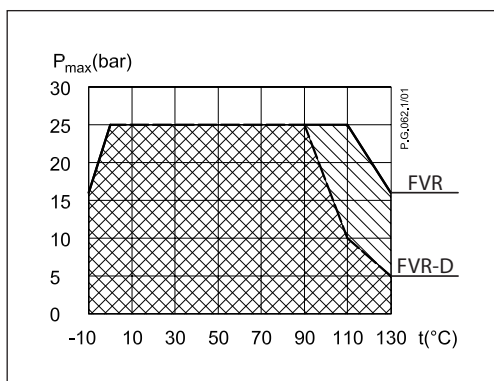

Sizing - Headloss chart

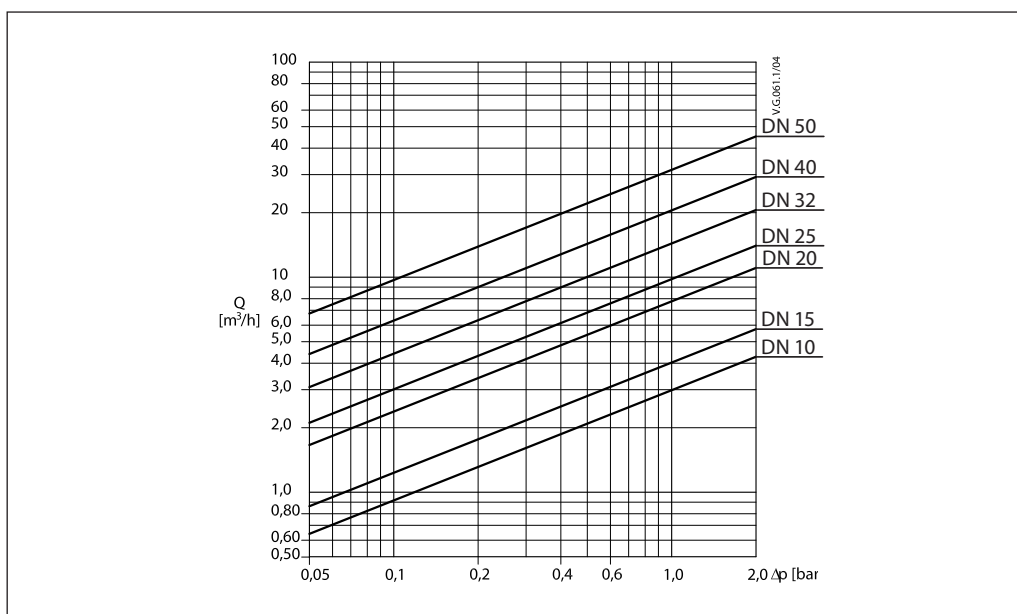

Design

1. Valve body
2. Screen
3. O-ring
4. Plug
5. Draining ball valve

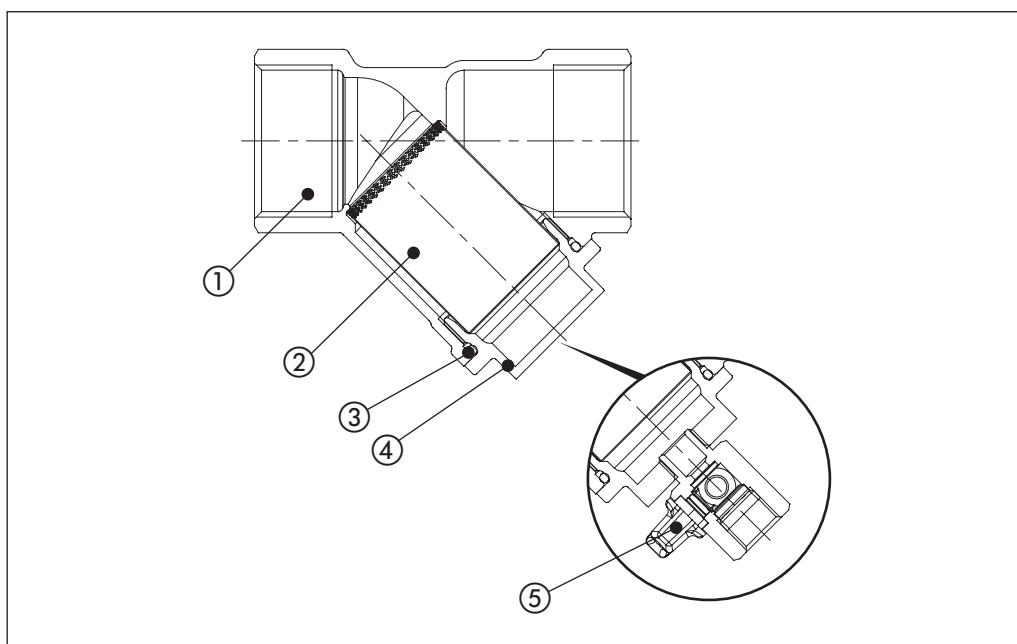

Dimensions

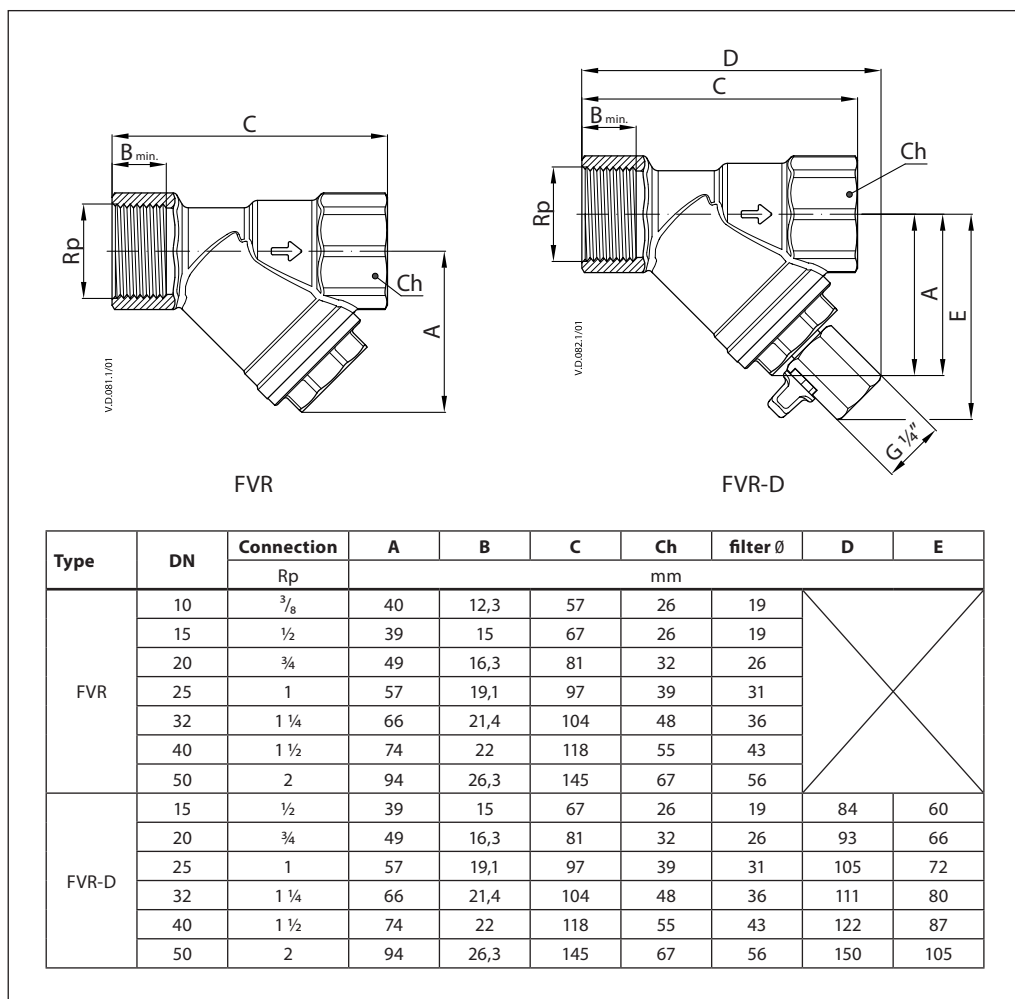

Danfoss can accept no responsibility for possible errors in catalogues, brochures and other printed material. Danfoss reserves the right to alter its products without notice. This also applies to products already on order provided that such alterations can be made without consequential changes being necessary in specifications already agreed. All trademarks in this material are property of the respective companies. Danfoss and the Danfoss logotype are trademarks of Danfoss A/S. All rights reserved.