

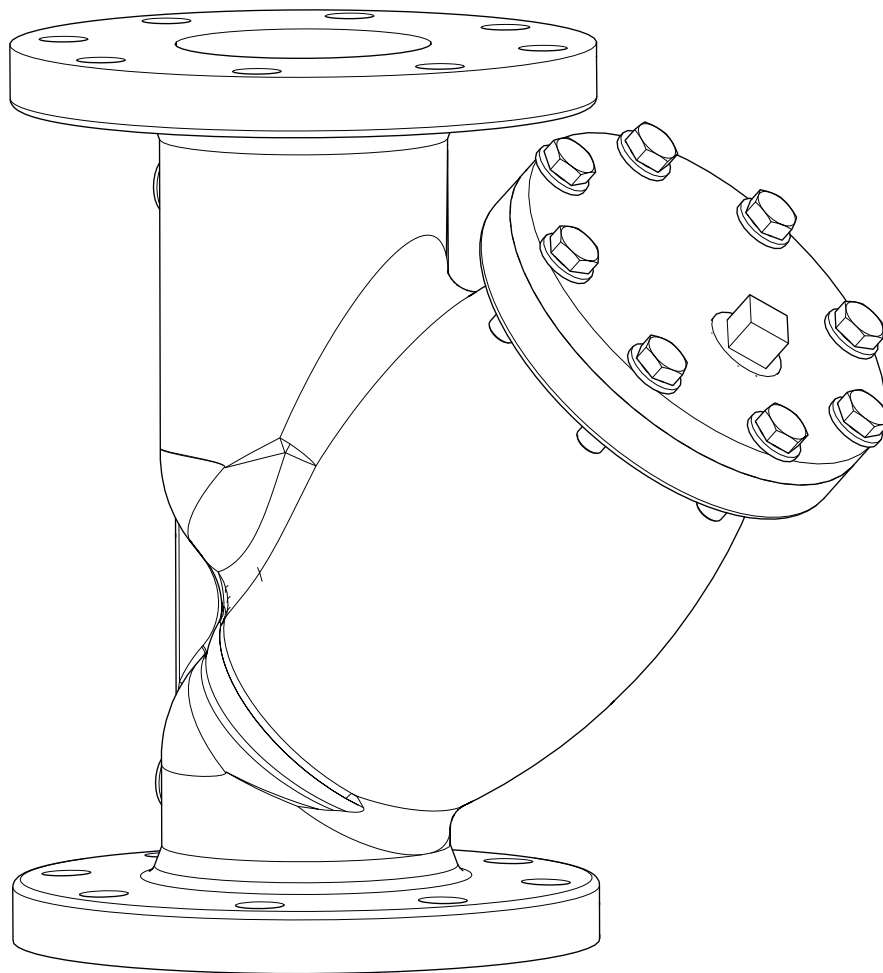

Strainer (flanged model) PN 16
DN15 - DN300
Operating instructions



Contents

	Page
1. General information	4
1.1 Validity of the operating instruction.....	4
1.2 Extent of supply	4
1.3 Contact.....	4
1.4 Declaration of conformity	4
1.5 Used symbols.....	4
2. Safety-related information.....	5
2.1 Correct use.....	5
2.2 Warnings	5
2.3 Safety notes	5
2.3.1 Danger caused by inadequately qualified personnel	5
2.3.2 Risk of injury from heavy product	5
2.3.3 Risk of injury from pressurised components.....	5
2.3.4 Risk of injury from hot or cold components and surfaces	6
2.3.5 Risk of injury in case of improper work.....	6
2.3.6 Availability of the operating instructions	6
3. Technical description	6
3.1 Construction.....	6
3.2 Functional description.....	6
3.3 Technical data	7
4. Accessories and spare parts.....	8
5. Transport and storage.....	8
6. Installation.....	8
7. Commissioning.....	9
8. Maintenance	9
9. Removal and disposal.....	9
10. Appendix	10

1. General information

The original operating instructions were drafted in German.

The operating instructions in other languages have been translated from German.

1.1 Validity of the operating instruction

These operating instructions are valid for the strainer (flanged model) PN 16.

DN	Item no.
15	112 20 45
20	112 20 46
25	112 20 47
32	112 20 48
40	112 20 49
50	112 20 50
65	112 20 51
80	112 20 52
100	112 20 53
125	112 20 54
150	112 20 55
200	112 20 56
250	112 20 57
300	112 20 58

1.2 Extent of supply

Please check your delivery for any damage caused during transit and for completeness.

Items included in the delivery:

- Strainer PN 16
- Safety and installation advice

1.3 Contact

Contact address

OVENTROP GmbH & Co. KG
 Paul-Oventrop-Straße 1
 59939 Olsberg
 GERMANY

www.omentrop.com

Technical services





Phone: +49 (0) 29 62 82-234

1.4 Declaration of conformity

Oventrop GmbH & Co. KG hereby declares that this product complies with the basic requirements and other relevant provisions of the EC Directives concerned.

The declaration of conformity can be obtained from the manufacturer.

1.5 Used symbols

	Highlights important information and further explanations.
	Action required
	List
1.	Fixed order. Steps 1 to X.
2.	
	Result of action

2. Safety-related information

2.1 Correct use

Operating safety is only guaranteed if the product is used correctly.

Oventrop strainers are used in central heating and cooling systems and industrial plants with closed circuits which are operated with non-aggressive and harmless fluids

Any other use of the product will be considered incorrect use.

Claims of any kind against the manufacturer and/or its authorised representatives due to damage caused by incorrect use will not be accepted.

Observance of the operating instructions is part of compliance with correct use.

2.2 Warnings

Each warning contains the following elements:

Warning symbol	SIGNAL WORD
	Type and source of danger! Possible consequences if the danger occurs or the warning is ignored. ▶ Ways to avoid the danger.

The signal words identify the severity of the danger arising from a situation.

	DANGER
	Indicates an imminent danger with high risk. The situation will lead to death or serious injury if not avoided.

	WARNING
	Indicates a possible danger with moderate risk. The situation may lead to death or serious injury if not avoided.

	CAUTION
	Indicates a possible danger with lower risk. The situation will lead to minor and reversible injury if not avoided.

NOTICE	
	Indicates a situation that may lead to damage to property if not avoided.

2.3 Safety notes

We have developed this product in accordance with current safety requirements.

Please observe the following notes concerning safe use.

2.3.1 Danger caused by inadequately qualified personnel

Any work on this product must only be carried out by qualified tradesmen.

As a result of their professional training and experience as well as their knowledge of the relevant legal regulations, qualified tradesmen are able to carry out any work on the described product professionally.

2.3.2 Risk of injury from heavy product

- ▶ Wear safety shoes during installation.
- ▶ Install the product with the help of several persons, if necessary.
- ▶ Use a suitable hoisting device if necessary.

2.3.3 Risk of injury from pressurised components

- ▶ Only carry out work when the system is depressurised.
- ▶ Observe the permissible operating pressures during operation.

2.3.4 Risk of injury from hot or cold components and surfaces

- ▶ Wear suitable protective clothing to avoid unprotected contact with hot or cold system components and fittings.
- ▶ If necessary, wait until the product has nearly reached the ambient temperature before carrying out work.

2.3.5 Risk of injury in case of improper work

Stored energies, angular components, protrusions and edges both inside and outside the product may cause injuries.

- ▶ Wear suitable protective clothing.
- ▶ Before starting work, make sure that there is enough space.
- ▶ Handle open and sharp-edged components with care.
- ▶ Make sure that the work place is tidy and clean to avoid accidents.

2.3.6 Availability of the operating instructions

Any person working on the product has to read and apply these operating instructions and all other valid documents.

The operating instructions must be available at the installation location of the product.

- ▶ Hand these operating instructions and all other relevant documents (e.g. accessory manuals) over to the user.

3. Technical description

3.1 Construction

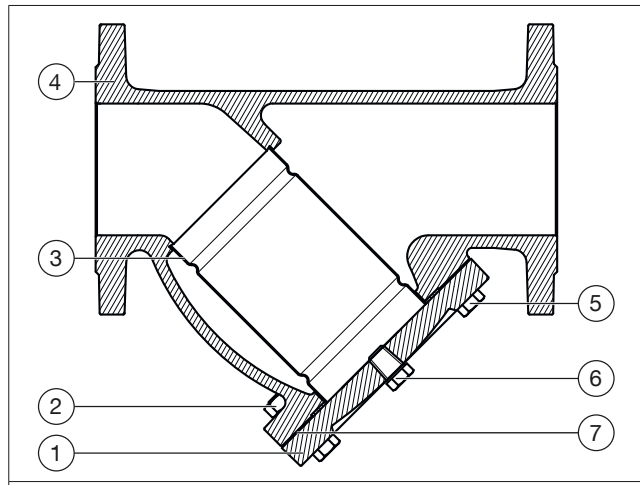

Illust. 1: Construction of the strainer

(1)	Cover
(2)	Nut
(3)	Screen
(4)	Body
(5)	Screw
(6)	Draining screw
(7)	Seal

3.2 Functional description

Oventrop strainers consist of an oblique pattern body with cover and a mounted wire basket.

They are installed in supply and return pipes of central heating and cooling systems in order to collect harmful impurities.

This increases the service life of the control and isolation fittings in the system and prevents the premature breakdown of machines and appliances.

3.3 Technical data

Operating pressure (p_s)	max. 16 bar (PN16)
Operating temperature (t)	0 to 120°C
Fluid	Non-aggressive, harmless fluids (e.g. water or water and glycol mixtures according to VDI 2035/ÖNORM 5195)
Flanged connections	According to DIN EN 1092-2 PN16

Materials	
Body, cover	Cast iron (EN GJL-250, DIN EN 1561)
Wire basket	Corrosion-resistant steel
Seal	asbestos-free

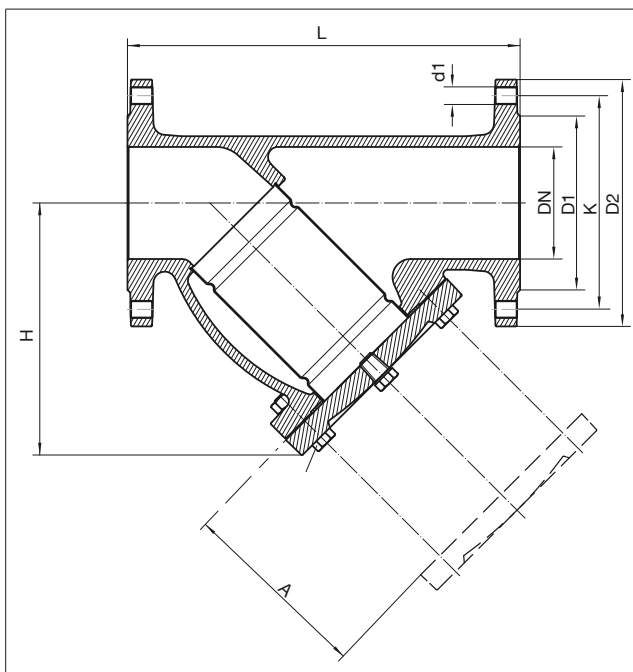

Illust. 2: Dimensions

	Item no. 1122045	Item no. 1122046	Item no. 1122047
H	85	90	95
L	130	150	160
DN	15	20	25
D1	46	56	65
K	65	75	85
D2	95	105	115
A	70	70	70
n x d1	4x14	4x14	4x14
Weight (kg)	3	4	5
Screen aperture width	1	1	1
k _{VS} value	7	10	15

	Item no. 1122048	Item no. 1122049	Item no. 1122050
H	105	120	148
L	180	200	230
DN	32	40	50
D1	76	84	99
K	100	110	125
D2	140	150	165
A	80	100	115
n x d1	4x19	4x19	4x19
Weight (kg)	7	8	11
Screen aperture width	1	1.5	1.5
k _{VS} value	21	39	60

	Item no. 1122051	Item no. 1122052	Item no. 1122053
H	193	205	245
L	290	310	350
DN	65	80	100
D1	118	132	156
K	145	160	180
D2	185	200	220
A	155	160	180
n x d1	4x19	8x19	8x19
Weight (kg)	16	18	27
Screen aperture width	1.5	1.5	1.5
k _{VS} value	105	140	225

	Item no. 1122054	Item no. 1122055	Item no. 1122056
H	295	325	390
L	400	480	600
DN	125	150	200
D1	184	212	266
K	210	240	295
D2	250	285	340
A	230	235	320
n x d1	8x19	8x23	12x23
Weight (kg)	38	47	85
Screen aperture width	1.5	1.5	2
k _{VS} value	340	405	715

	Item no. 1122057	Item no. 1122058	
H	460	500	
L	730	850	
DN	250	300	
D1	319	370	
K	355	410	
D2	405	460	
A	365	415	
n x d1	12x28	12x28	
Weight (kg)	145	200	
Screen aperture width	2	2	
k _{VS} value	1355	1890	

4. Accessories and spare parts

Wire basket and blind flange ring gasket

Accessories	Item no.
DN 15/20	1122085
DN 25	1122087
DN 32	1122088
DN 40	1122089
DN 50	1122090
DN 65	1122091
DN 80	1122092
DN 100	1122093
DN 125	1122094
DN 150	1122095
DN 200	1122096
DN 250	1122097
DN 300	1122098

5. Transport and storage

Temperature range	-20 °C to +55 °C
Relative air humidity	Max. 95 %
Particles	Store dry and free from dust
Mechanical influences	Protected from mechanical agitation
Weather influences	Do not store outdoors
	Protect from direct sunlight
Chemical influences	Do not store together with aggressive fluids

6. Installation

	<ul style="list-style-type: none"> - We recommend installing an Oventrop strainer in every pipe. - You can install the strainer both vertically and horizontally. <ul style="list-style-type: none"> ▶ Make sure that the product and the pipe-work are free from impurities. ▶ Observe the direction of flow. ▶ When installing vertically, make sure that the wire basket is facing downwards in order to collect the impurities. ▶ Install the product free from tension. ▶ Ensure that the area in front of the cover remains unobstructed (see dimension A in Illust. 2 auf Seite 7).
---	--

 WARNING	
	<p>Risk of injury from heavy product</p> <ul style="list-style-type: none"> ▶ Wear safety shoes during installation. ▶ Install the product with the help of several persons, if necessary. ▶ Use a suitable hoisting device if necessary.

 WARNING	
	<p>Risk of injury from pressurised components</p> <p>Fluids escaping under pressure may lead to injuries.</p> <ul style="list-style-type: none"> ▶ Only carry out work when the system is depressurised. ▶ When retrofitting an existing system: drain the system or close the supply pipes of the section of the system and depressurise it. ▶ Wear safety goggles.

 CAUTION
<p>Risk of injury from hot or cold components and surfaces</p> <ul style="list-style-type: none"> ▶ Wear suitable protective clothing to avoid unprotected contact with hot or cold system components and fittings. ▶ If necessary, wait until the product has nearly reached the ambient temperature before carrying out work.

1. Remove the adhesive foil on the flanges.
2. Align the strainer exactly with the adjoining flanges. Fully use the sealing surface.
3. Tighten the flange screws by hand.
4. Tighten the flange screws crosswise.

7. Commissioning

- ▶ Before commissioning, fill and bleed the installation, with due consideration of the permissible operating pressures.
- ▶ After installation, check all installation points for leaks.

8. Maintenance

 WARNING
<p>Risk of injury from pressurised components</p> <p>Fluids escaping under pressure may lead to injuries.</p> <ul style="list-style-type: none"> ▶ Only carry out work when the system is depressurised. ▶ Wear safety goggles.

 CAUTION
<p>Risk of injury from hot or cold components and surfaces</p> <ul style="list-style-type: none"> ▶ Wear suitable protective clothing to avoid unprotected contact with hot or cold system components and fittings. ▶ If necessary, wait until the product has nearly reached the ambient temperature before carrying out work.

- ▶ Unscrew the cover (see position 1 in Illust. 1 auf Seite 6) in order to clean the wire basket.

	<p>The cleaning interval for the wire basket is dependent on the degree of contamination of the fluid being used.</p>
---	---

9. Removal and disposal

 WARNING
<p>Risk of injury from pressurised components</p> <p>Fluids escaping under pressure may lead to injuries.</p> <ul style="list-style-type: none"> ▶ Only carry out work when the system is depressurised. ▶ Wear safety goggles.

 CAUTION
<p>Risk of injury from hot or cold components and surfaces</p> <ul style="list-style-type: none"> ▶ Wear suitable protective clothing to avoid unprotected contact with hot or cold system components and fittings. ▶ If necessary, wait until the product has nearly reached the ambient temperature before carrying out work.

NOTICE
<p>Risk of environmental pollution!</p> <p>Incorrect disposal (for instance with standard waste) may lead to environmental damage.</p> <ul style="list-style-type: none"> ▶ Dispose of packaging material in an environmentally friendly manner. ▶ Dispose of the components appropriately.

If no return or disposal agreement has been made, dispose of the product yourself.

- ▶ If possible, recycle the components.
- ▶ Dispose of components which cannot be recycled according to local regulations.

10. Appendix

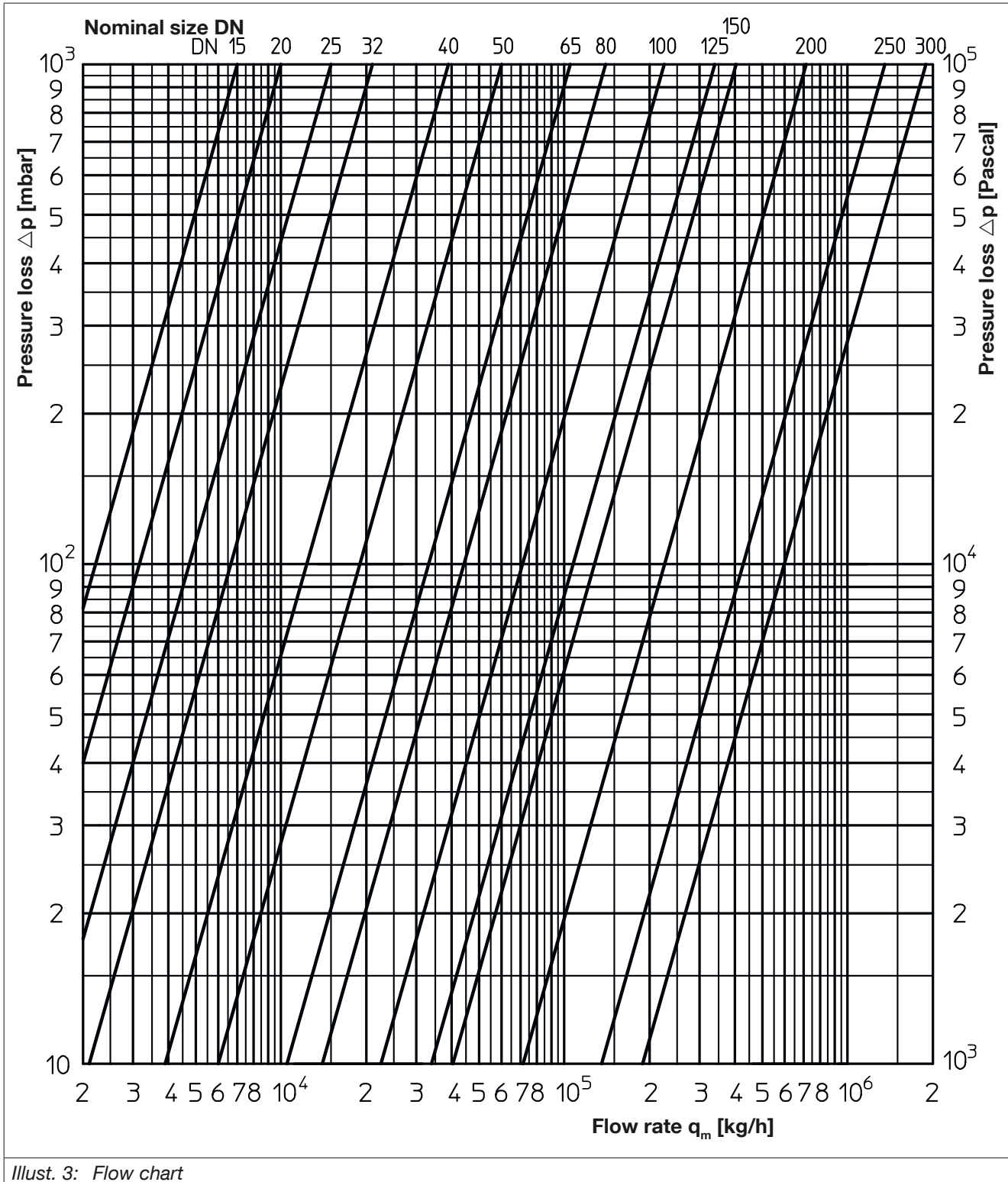

Illust. 3: Flow chart

