

Flanged model

☑ Dimension

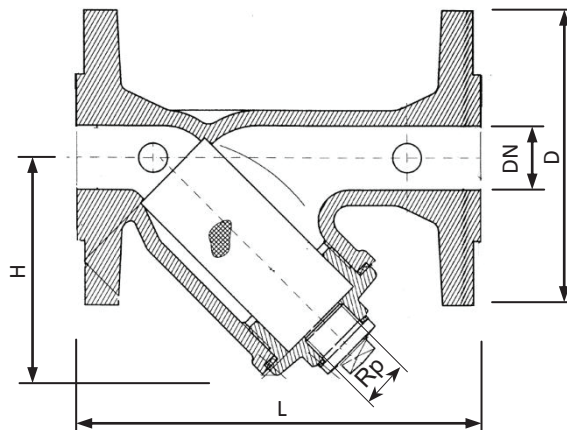

Order number	DN	PN [bar]	D [mm]	L [mm]	H [mm]	Kvs [m ³ /h]	Mass [kg]	Rp ["]
1 4111 83	25	16	115	160	85	12,8	4	1/2
1 4111 84	32	16	140	180	105	25,1	5,8	1/2
1 4111 85	40	16	150	200	140	34,3	7,6	3/4

☑ Materials

Body	grey cast iron EN GJL- 250, painted blue
Flange	EN1092-2, ISO 7005-2
Mesh	expanded metal, rhombic decoration, Stainless steel 1.4301, DN25 - DN50, Mesh size 0,75mm DN65 - DN80, Mesh size 1,25mm
Sealings	Graphite Cardboard, asbestos free

☑ Technical Data

Max. operating pressure	16 bar
Max. operating temperature	130°C
Heating water quality according ÖNORM H5195 or VDI-Standard 2035.	
The use of ethylene or propylene glycol in a mixing ratio 25- 50% is allowed.	

☑ Application

Strainers are installed in pipes to protect the finely machined valve seats from particles. Field of application are building services, such as in heating or chilled water units for air conditioning in buildings. EPDM Sealings can be destroyed by organic hydrocarbons, which are occurring in natural gas or mineral oil.

☑ Installation and maintenance

A horizontal or vertical installation is possible taking into account the flow direction. The screening space should face down. The strainer can be removed and cleaned by opening the locking screw. Drain the system before opening the locking screw. Reassemble in reverse order. Damage to the sealings have to be avoided. For service it is recommended to install isolators before and after the strainer.

☑ Spare Parts

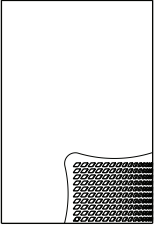
Illustration	Description	Item number	Suitable with
	Mesh 0,75mm	1 6386 23	1 4111 83
		1 6386 24	1 4111 84
		1 6386 25	1 4111 85
		1 6386 26	1 4111 86
	Mesh 1,25mm	1 6386 27	1 4111 87
		1 6386 28	1 4111 88

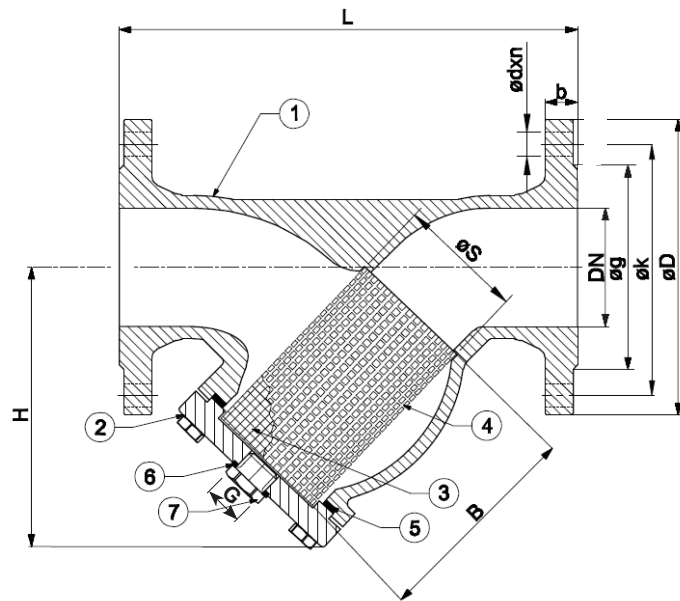
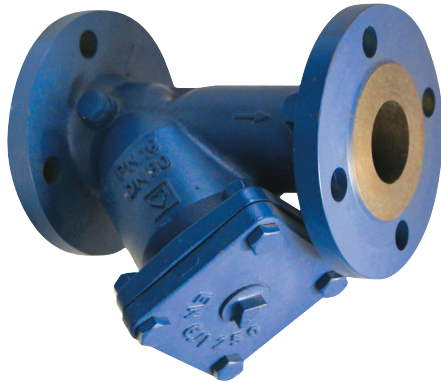
☑ Dimensions

Order number	DN [mm/"]	L [mm]	H [mm]	H _{max} [mm]	B [mm]	S [mm]	D [mm]	k [mm]	g [mm]	b [mm]	d [mm]	n [mm]	G [°]	Mass [kg]	Mesh [μm]
4 4111 80	50 2"	230	145	260	98	55	165	125	99	20	19	4	3/4	10,5	2000
4 4111 81	65 2-1/2"	290	165	333	132	78	185	145	118	20	19	4	3/4	16	2000
4 4111 82	80 3"	310	175	363	149	87	200	160	132	22	19	8	3/4	21,5	2000
4 4111 83	100 4"	350	236	454	192	109	220	180	156	24	19	8	3/4	28,5	2000
4 4111 84	125 5"	400	267	510	227	135	250	210	184	26	19	8	3/4	39	4000
4 4111 85	150 6"	480	298	579	244	160	285	240	211	26	23	8	3/4	52,5	4000
4 4111 86	200 8"	600	340	657	313	210	340	295	266	30	23	12	3/4	89,5	5000
4 4111 87	250 10"	730	390	875	394	258	405	355	319	32	28	12	1 1/4	149	5000
4 4111 88	300 12"	850	440	960	434	308	460	410	370	32	28	12	1 1/4	228	6000
4 4111 89	350 14"	980	520	1160	630	365	520	470	429	36	28	16	1 1/4	340	6000
4 4111 90	400 16"	1100	630	1329	645	410	580	525	480	38	31	16	1 1/4	505	6000
4 4111 92	500 20"	1250	900	1750	720	495	715	650	609	31.5	34	20	2	610	6000

☑ Specification

Temperature range: -10°C ... +120°C
 Pressure rate: PN16
 Flange Dimensions according to EN1092-2

For hot and cold water systems for fluids excluding acid and flammable fluids. Heating water quality according ÖNORM H5195 or VDI-Standard 2035. The use of ethylene or propylene glycol in a mixing ratio 25- 50% is allowed.

Materials

Body (1)	DN 50 - DN300: grey cast iron EN - GJL-250, painted blue DN350 - DN500: spheroidal graphite iron EN - GJS-400-15, painted blue
Bonnet (2)	DN 50 - DN300: grey cast iron EN - GJL-250, painted blue DN350 - DN500: spheroidal graphite iron EN - GJS-400-15, painted blue
Filter (3)	Stainless steel AISI 304
Reinforcing frame (4)	Stainless steel
Gasket (5)	Klingerit
Plug gasket (6)	Copper
Plug (7)	St37

 kvs values

DN	Kvs
50	51
65	70
80	114
100	197
125	271
150	349
200	449
250	994
300	1396
350	2461
400	3645
500	5675

 Pressure loss calculation

The pressure loss in the valve can be calculated with below given formula.

$$1. \quad h_v = \frac{\zeta * w^2}{2g} \quad 2. \quad \Delta p = \zeta \frac{\rho * w^2}{2}$$

h_v	pressure loss (m)
Δp	pressure loss (Pa)
w	flow rate (m/s)
ζ	pressure loss coefficient
ρ	density (kg/m ³)
g	9,81 m/s ²

DN	50	...	400
ζ		~ 2,8	

 Spare Parts

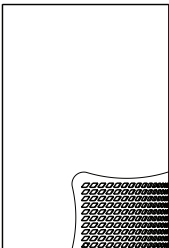
Illustration	Description	Item number	DN	Suitable with
	Mesh 2 mm	1 6387 60	50	4 4111 80
	Mesh 2 mm	1 6387 61	65	4 4111 81
	Mesh 2 mm	1 6387 62	80	4 4111 82
	Mesh 2 mm	1 6387 63	100	4 4111 83
	Mesh 4 mm	1 6387 64	125	4 4111 84
	Mesh 4 mm	1 6387 65	150	4 4111 85
	Mesh 5 mm	1 6387 66	200	4 4111 86
	Mesh 5 mm	1 6387 67	250	4 4111 87
	Mesh 6 mm	1 6387 68	300	4 4111 88
	Mesh 6 mm	1 6387 69	350	4 4111 89
Mesh 6 mm	1 6387 70	400	4 4111 90	

Please note: All specifications and information within this document are reflecting the information available at the time of going to print and meant for informational purpose only. Herz Armaturen reserves the right to modify and change products as well as its technical specifications and/or its function according to technological progress and requirements. All diagrams are indicative in nature and do not to be complete. It is understood that all images of Herz products are symbolic representations and therefore may visually differ from the actual product. Colours may differ due to printing technology used. In case of any further questions don't hesitate to contact your closest HERZ Branch-Office.

HERZ - Strainer	with female thread
Order No: 2662	DN 15 - DN50

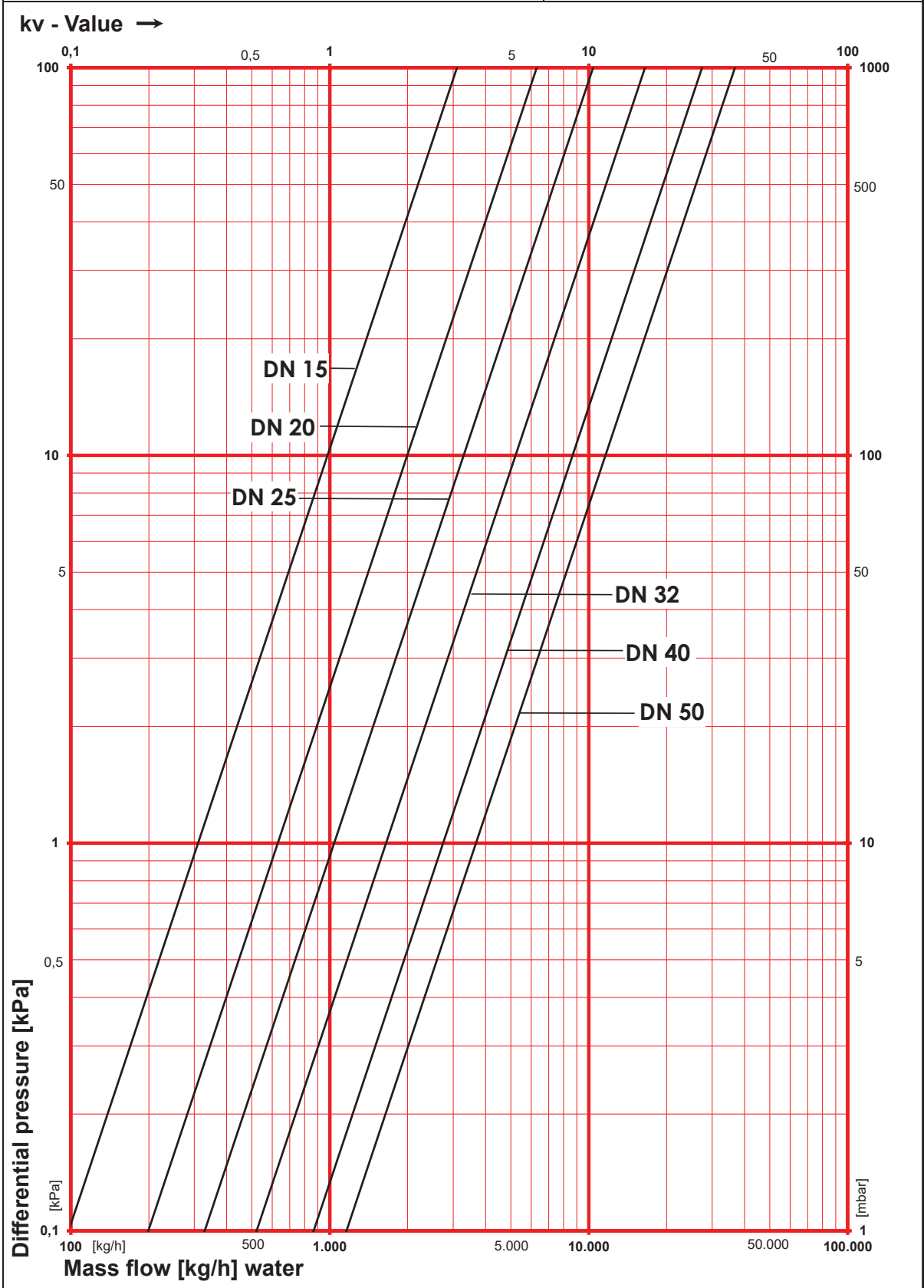

HERZ - Strainer	with female thread
Order No: 4111	DN 32 - DN80

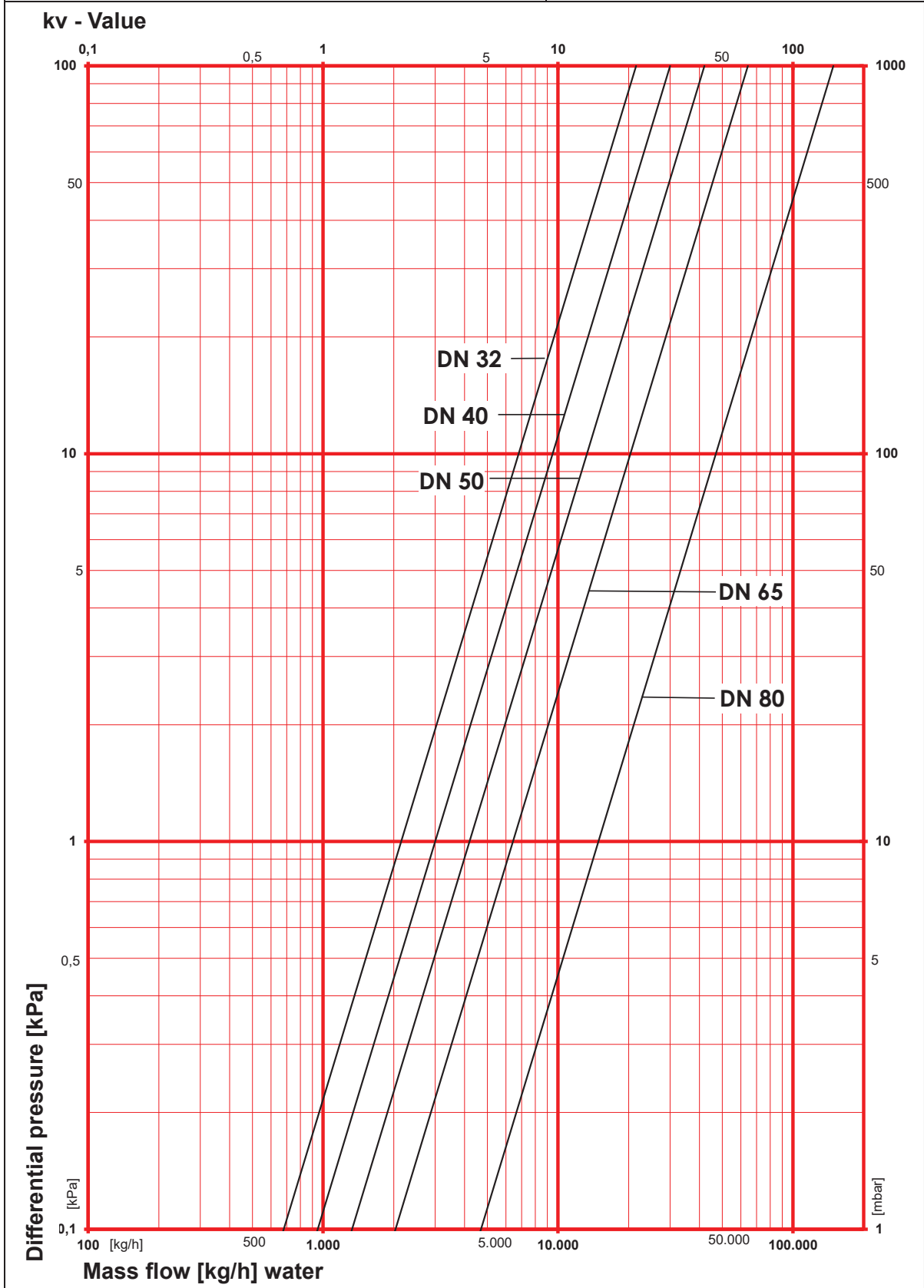

HERZ - Strainer	with male thread
Order No: 1 4111 2X	DN15 - DN32

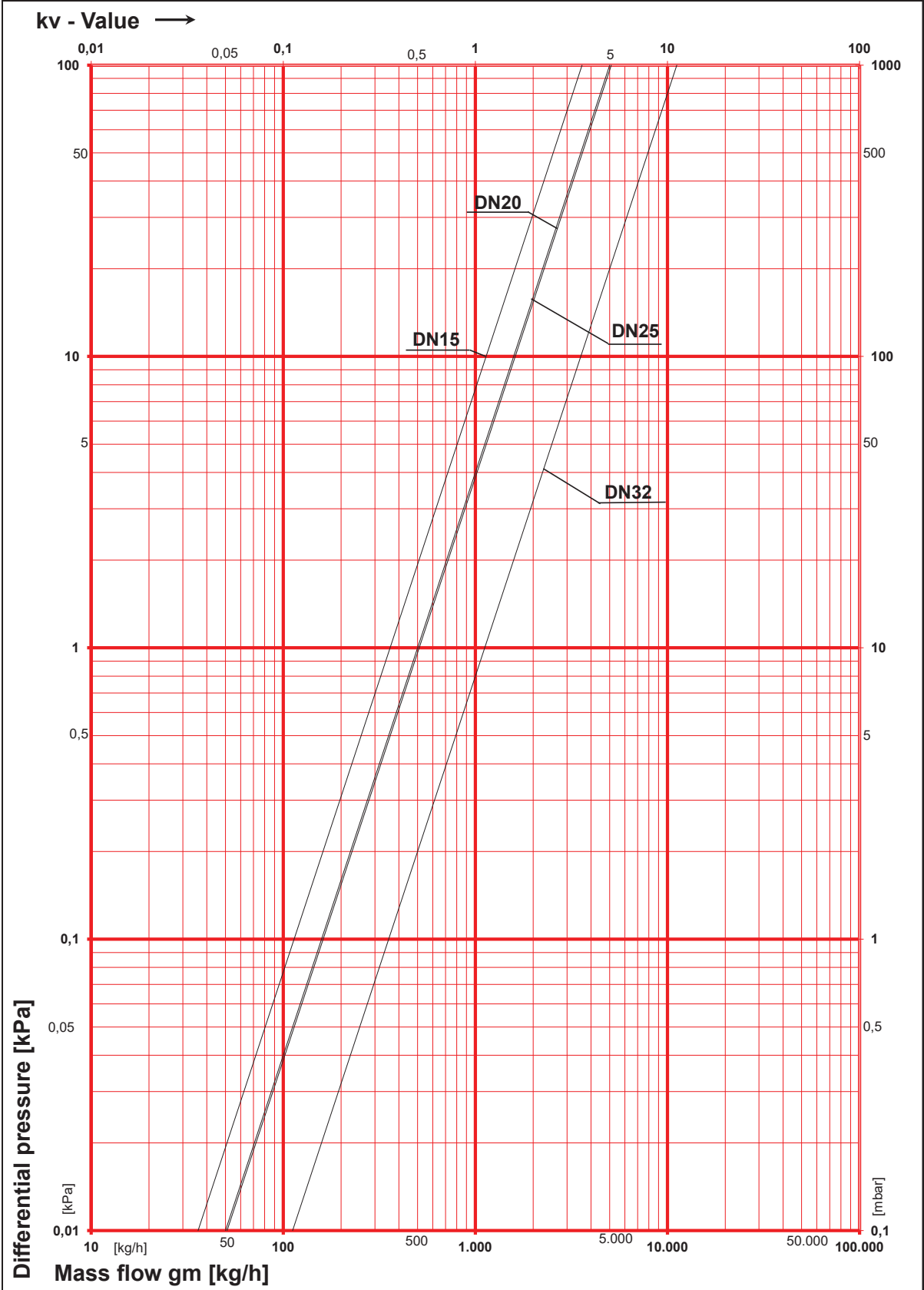

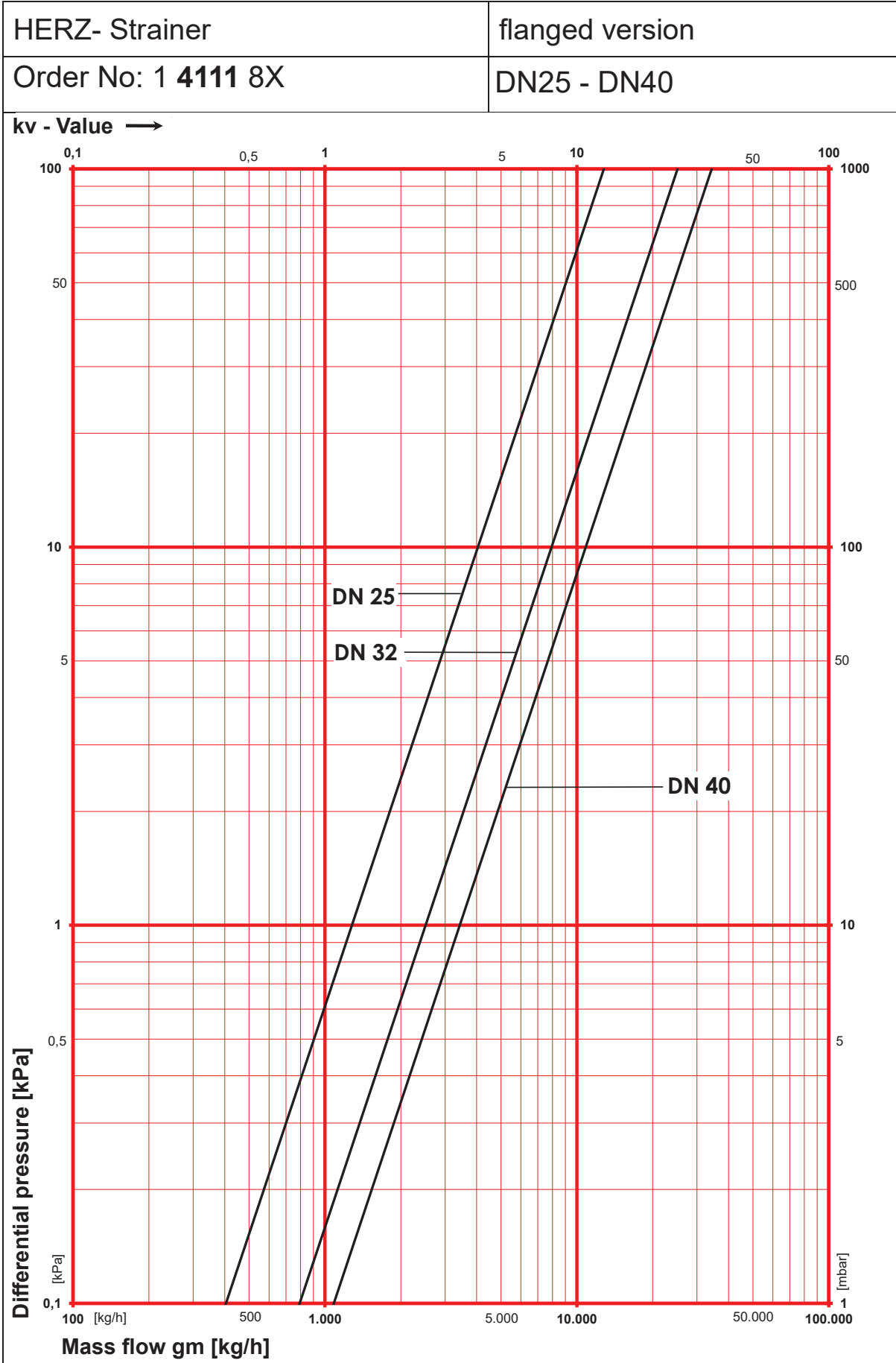

HERZ- Strainer

flanged version

Order No: 4 4111 8X

DN50 - DN500

