

# Installation and service instructions for contractors

**VIESSMANN**

## **Vitocell 300-V/-W**

### **Type EVIB-A+**

160 and 200 l

### **Type EVIB-A**

160 to 300 l

### **Type EVIA-A**

500 l

DHW cylinder with internal indirect coil

## **VITOCCELL 300-V/-W**



### Safety instructions

-  Please follow these safety instructions closely to prevent accidents and material losses.

### Safety instructions explained

-  **Danger**  
This symbol warns against the risk of injury.

**Note**  
*Details identified by the word "Note" contain additional information.*

-  **Please note**  
This symbol warns against the risk of material losses and environmental pollution.

### Target group

These instructions are exclusively intended for qualified contractors.

- Work on electrical equipment may only be carried out by a qualified electrician.
- The system must be commissioned by the system installer or a qualified person authorised by the installer.

### Regulations to be observed

- National installation regulations
- Statutory regulations for the prevention of accidents
- Statutory regulations for environmental protection
- Codes of practice of the relevant trade associations
- Relevant country-specific safety regulations

### Working on the system

- Isolate the system from the power supply (e.g. by removing the separate fuse or by means of a mains isolator) and check that it is no longer live.
- Safeguard the system against reconnection.

-  **Danger**  
Hot surfaces can cause burns.
- Before maintenance and service work, switch OFF the appliance and let it cool down.
  - Never touch the hot surfaces of uninsulated pipes and fittings.

-  **Please note**  
Electronic assemblies can be damaged by electrostatic discharge. Prior to commencing any work, touch earthed objects such as heating or water pipes to discharge static loads.

**Safety instructions** (cont.)**Danger**

Floors that are wet or damp with water or glycol based liquids can cause injury due to slipping and falling.

- Keep the floor clean and dry during installation and maintenance work.
- Wear non-slip shoes.

**Danger**

Broken-off fragments of insulation material can cause death by suffocation if inhaled or swallowed.

- Do not let children play in the installation room.
- Keep the installation room clean after installation and maintenance work.

---

**Repair work****Please note**

Repairing components that fulfil a safety function can compromise the safe operation of the system. Replace faulty components only with genuine Viessmann spare parts.

---

**Auxiliary components, spare and wearing parts****Please note**









Spare and wearing parts that have not been tested together with the system can compromise its function. Installing non-authorized components and making non-approved modifications or conversions can compromise safety and may invalidate our warranty. For replacements, use only original spare parts supplied or approved by Viessmann.

1.	<b>Information</b>	Disposal of packaging .....	5
		Symbols .....	5
		Intended use .....	5
		Product information .....	6
		■ System examples .....	6
		■ Maintenance parts and spare parts .....	6
		Inspection and maintenance .....	6
2.	<b>Preparing for installation</b>	Unpacking and handling (160, 200 and 300 l) .....	7
		Connections .....	8
		Information on siting .....	8
		■ Siting a DHW cylinder with an immersion heater EHE .....	9
3.	<b>Installation sequence</b>	160 to 300 l capacity .....	10
		■ Fitting the cylinder temperature sensor and thermometer sensor (if supplied) .....	10
		■ Attach the cover and cap, affix the type plate .....	11
		500 l capacity .....	12
		■ Siting the DHW cylinder and fitting the thermal insulation mat at the bottom .....	12
		■ Fitting the thermometer sensor (if supplied) and cylinder temperature sensor .....	13
		■ Fitting the thermal insulation jacket .....	14
		■ Fitting the cover strips .....	15
		■ Fitting the cover .....	16
		Connections on the heating water side .....	16
		Connections on the DHW side .....	17
		■ Safety valve .....	18
		Connecting the DHW circulation pipe for cylinder banks .....	18
		■ In conjunction with boilers or district heating systems <b>without</b> heating water return temperature limiting facility and a DHW circulation pipe .....	19
		■ In conjunction with district heating systems <b>with</b> a return temperature limiting facility on the heating water side and/or in conjunction with several DHW circulation pipes .....	19
		Connecting the equipotential bonding .....	20
4.	<b>Commissioning, inspection, maintenance</b>	Steps - commissioning, inspection and maintenance .....	21
5.	<b>Commissioning/service reports</b>	.....	26
6.	<b>Specification</b>	.....	27
7.	<b>Disposal</b>	Final decommissioning and disposal .....	29
8.	<b>Certificates</b>	Declaration of conformity .....	30
9.	<b>Keyword index</b>	.....	31







## Disposal of packaging

Please dispose of packaging waste in line with statutory regulations.

## Symbols

Symbol	Meaning
	Reference to other document containing further information
	Step in a diagram: The numbers correspond to the order in which the steps are carried out.
	Warning of material losses and environmental pollution
	Live electrical area
	Pay particular attention.
	<ul style="list-style-type: none"> <li>Component must audibly click into place. or</li> <li>Acoustic signal</li> </ul>
	<ul style="list-style-type: none"> <li>Fit new component. or</li> <li>In conjunction with a tool: Clean the surface.</li> </ul>
	Dispose of component correctly.
	Dispose of component at a suitable collection point. Do <b>not</b> dispose of component in domestic waste.

The steps in connection with commissioning, inspection and maintenance are found in the "Commissioning, inspection and maintenance" section and identified as follows:

Symbol	Meaning
	Steps required during commissioning
	Not required during commissioning
	Steps required during inspection
	Not required during inspection
	Steps required during maintenance
	Not required during maintenance

## Intended use

The appliance is only intended to be installed and operated in sealed unvented systems that comply with EN 12828 / DIN 1988, or solar thermal systems that comply with EN 12977, with due attention paid to the associated installation, service and operating instructions. DHW cylinders are only designed to store and heat water of potable water quality. Heating water buffer cylinders are only designed to hold fill water of potable water quality. Only operate solar collectors with the heat transfer medium approved by the manufacturer.

Intended use presupposes that a fixed installation in conjunction with permissible, system-specific components has been carried out.

Commercial or industrial usage for a purpose other than heating the building or DHW shall be deemed inappropriate.

Any usage beyond this must be approved by the manufacturer for the individual case.

## Information

### Intended use (cont.)

Incorrect usage or operation of the appliance (e.g. the appliance being opened by the system user) is prohibited and results in an exclusion of liability.

Incorrect usage also occurs if the components in the system are modified from their intended use (e.g. through direct DHW heating in the collector).

Adhere to statutory regulations, especially concerning the hygiene of potable water.

### Product information

#### Vitocell 300-V/-W, type EVIB-A+, EVIB-A and EVIA-A

Stainless steel DHW cylinder with internal indirect coil for DHW heating in conjunction with floorstanding and wall mounted boilers

- The use of an immersion heater EHE is possible for 300 and 500 l cylinder capacities.
- Suitable for systems to DIN 1988, EN 12828 and DIN 4753

#### Capacities:

- Type EVIB-A+: 160 and 200 l
- Type EVIB-A: 160, 200 and 300 l
- Type EVIA-A: 500 l

#### Colours:

- Vitocell 300-V, Vitosilver, Vitoppearlwhite and Vitographite
- Vitocell 300-W, Vitoppearlwhite

### System examples

Available system examples: See [www.viessmann-schemes.com](http://www.viessmann-schemes.com).

### Maintenance parts and spare parts

Maintenance parts and spare parts can be identified and ordered directly online.

#### Viessmann Partnership

Login:  
<https://shop.viessmann.com/>



#### Viessmann spare part app

[www.viessmann.com/etapp](http://www.viessmann.com/etapp)



### Inspection and maintenance

DIN 1988 requires a visual inspection and (if necessary) cleaning no later than 2 years after the cylinder has been commissioned, and thereafter according to requirements.

Unpacking and handling (160, 200 and 300 l)

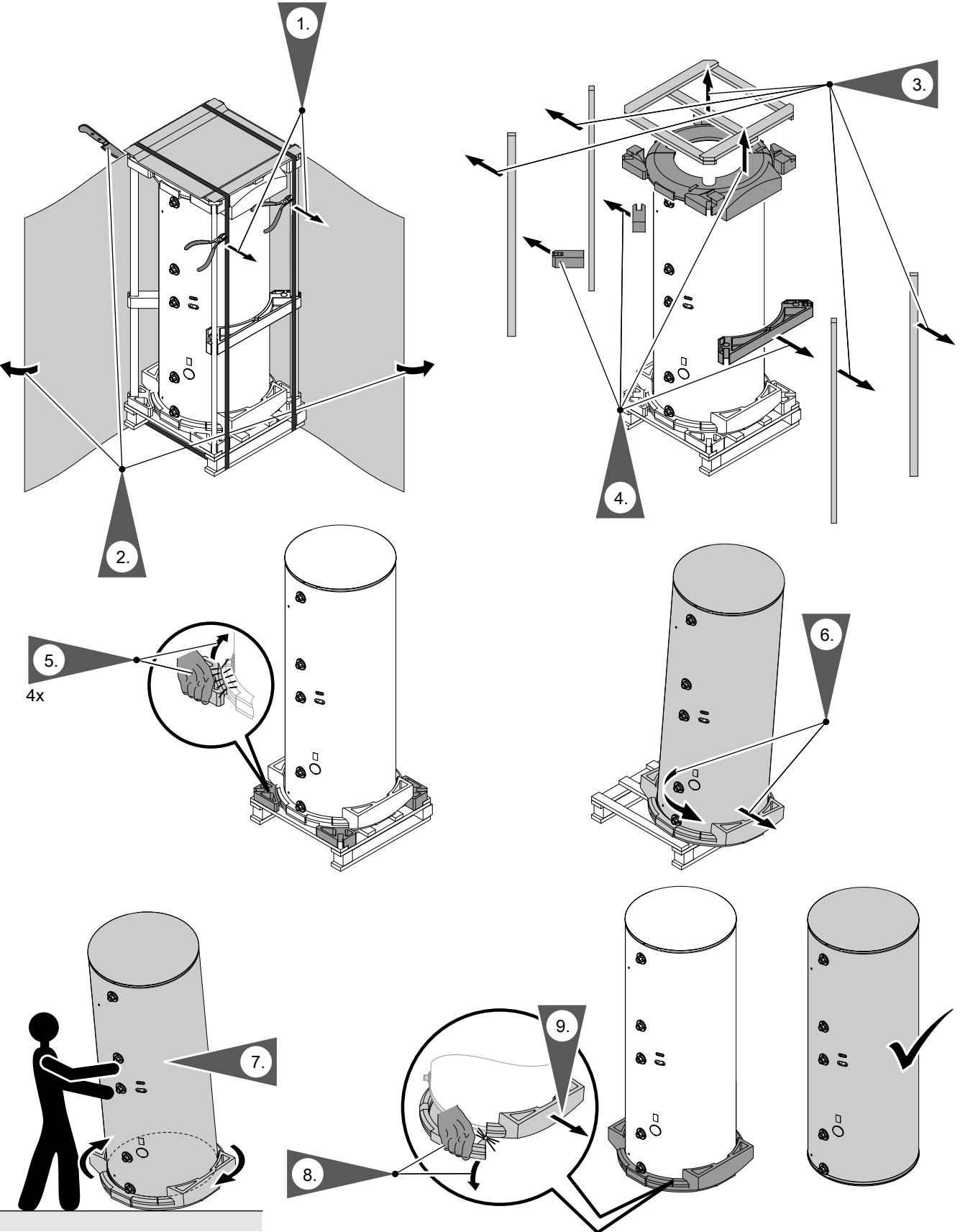

Fig. 1

Installation

**Connections**

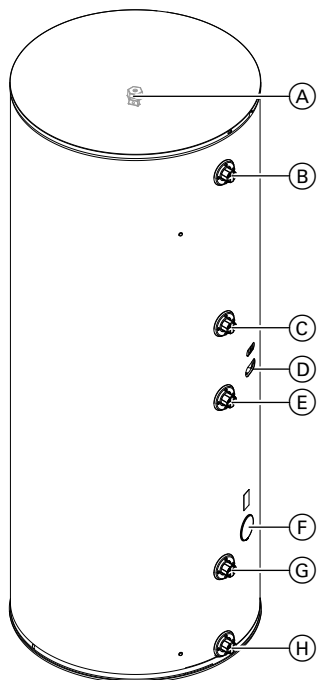

Fig. 2 160, 200 and 300 l capacity

- (A) High limit safety cut-out (if installed), below the thermal insulation
- (B) DHW
- (C) DHW circulation
- (D) Clamping device for cylinder temperature sensor
- (E) Heating water flow
- (F) Injection process plug for insulating foam (do not use, keep closed)
- (G) Heating water return
- (H) Cold water

500 l

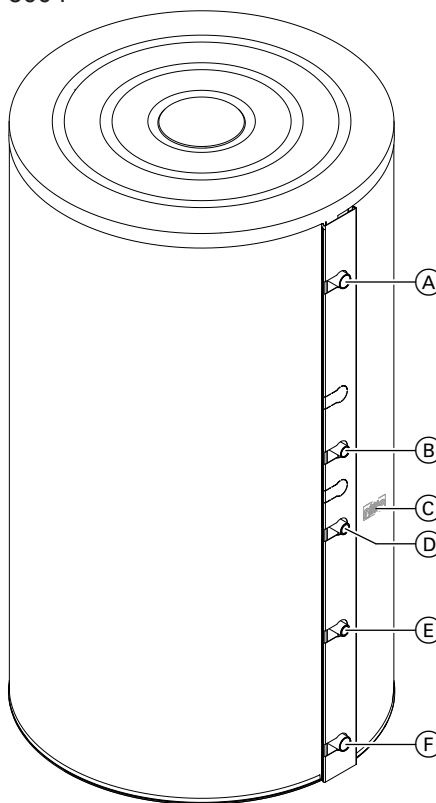

Fig. 3

- (A) DHW
- (B) DHW circulation
- (C) Clamp (behind the thermal insulation) for cylinder temperature sensor or temperature controller
- (D) Heating water flow
- (E) Heating water return
- (F) Cold water

**Information on siting**

**! Please note**  
The thermal insulation must not come into contact with naked flames.  
Exercise caution when welding and brazing.

**! Please note**  
To prevent material damage, site the DHW cylinder in a room free from the risk of frost and draughts.  
Alternatively, drain the DHW cylinder when not in use and there is a risk of frost.

Use the adjustable feet to level the DHW cylinder.

**Note**  
Only use one or two of the adjustable feet to level the DHW cylinder. At least one of the adjustable feet must remain fully screwed in.

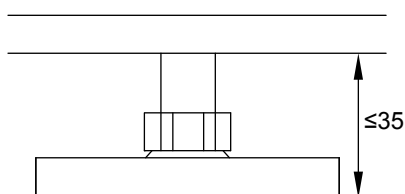

Fig. 4

**Do not extend the adjustable feet beyond a total length of 35 mm.**



**Information on siting** (cont.)

**Siting a DHW cylinder with an immersion heater EHE**

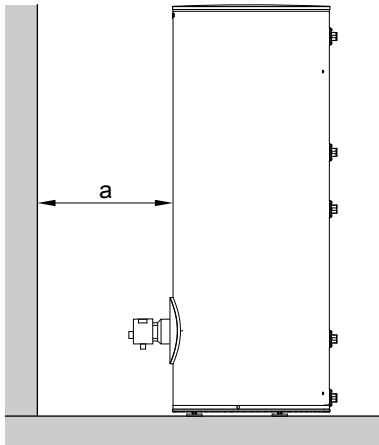

Fig. 5 Example: 300 l capacity



Immersion heater EHE installation instructions

Maintain the minimum clearance.

Cylinder capacity in l	Dim. a in mm
300	min. 730
500	min. 670

**Note**

*The unheated length of any threaded immersion heater installed on site must be at least 100 mm.*

Fitting the cylinder temperature sensor and thermometer sensor (if supplied)

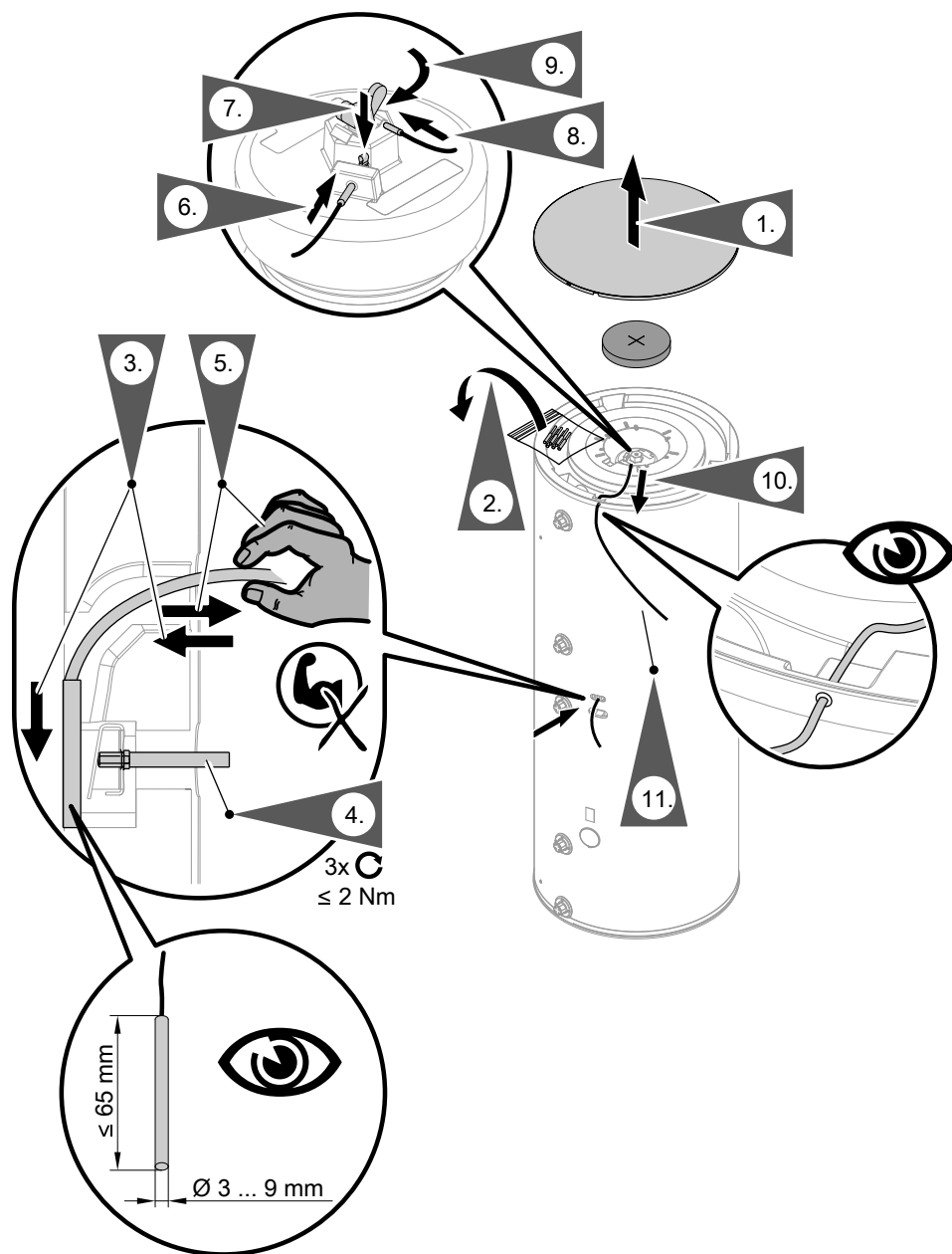

Fig. 6

3. Insert the cylinder temperature sensor as far as it will go into the opening of the clamping device.
4. Hand-tighten the cylinder temperature sensor with the screw provided. When doing so, hold the cylinder temperature sensor in place in the sensor clamp until the screw is screwed in.



**Please note**

Overtightening the fixing screw may damage the cylinder temperature sensor.  
Torque: Max. 2 Nm

5. Pull gently on the lead from the cylinder temperature sensor to check that it is securely fitted in the clamping device.

6. Insert the upper thermometer sensor as far as it will go into the hole in the cylinder cap.
7. Use clips to secure the thermometer sensor against being pulled out.
8. Insert the sensor of the high limit safety cut-out into the hole next to the wing screw.
9. Tighten the wing screw.
10. Guide the thermometer lead through the groove in the thermal insulation and the hole in the sheet steel casing.

160 to 300 l capacity (cont.)

11. Secure the thermometer (accessory) to the wall.

 Installation instructions for wall thermometer

Attach the cover and cap, affix the type plate

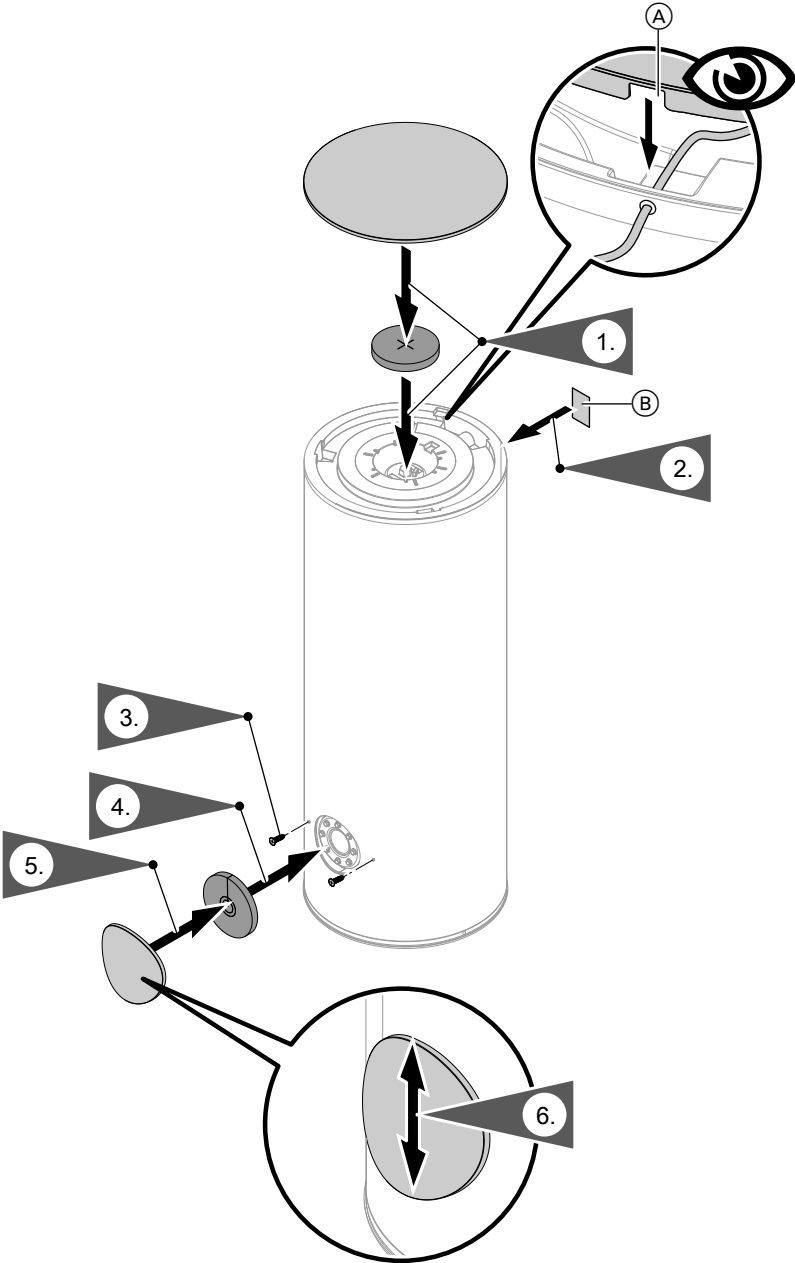

Fig. 7

- (A) Recess in top cover for thermometer cable
- (B) Type plate

Siting the DHW cylinder and fitting the thermal insulation mat at the bottom

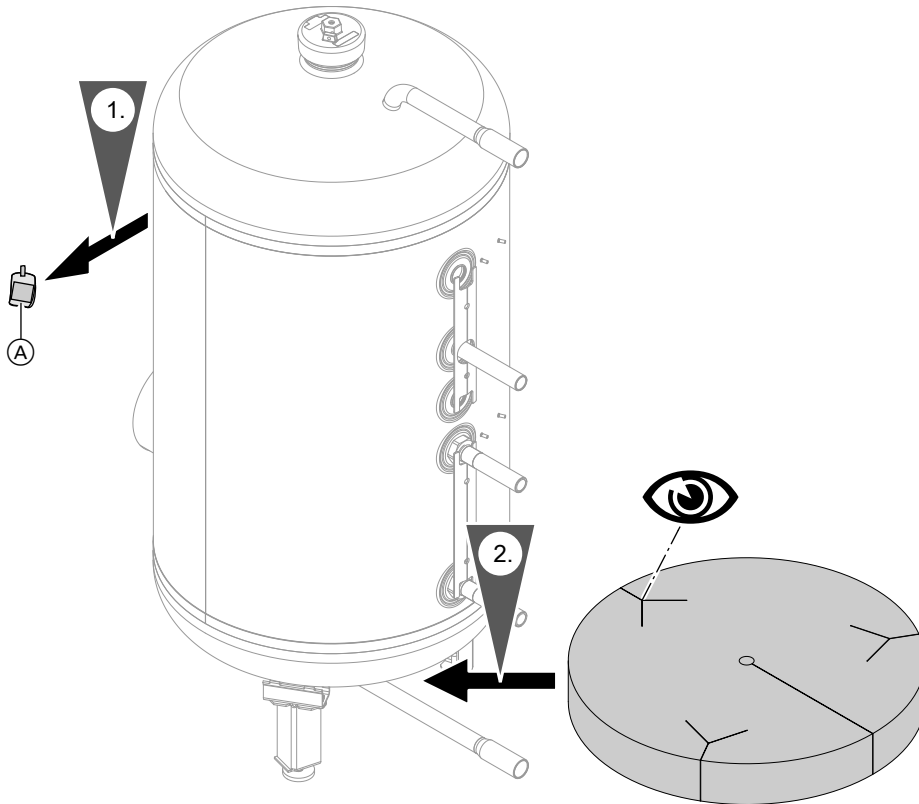

Fig. 8

(A) Type plate

**Note**

Only use one or two of the adjustable feet to level the DHW cylinder. At least one of the adjustable feet must remain fully screwed in.

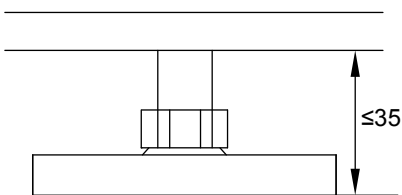

Fig. 9

Do **not** extend the adjustable feet beyond a total length of 35 mm.

## 500 l capacity (cont.)

## Fitting the thermometer sensor (if supplied) and cylinder temperature sensor

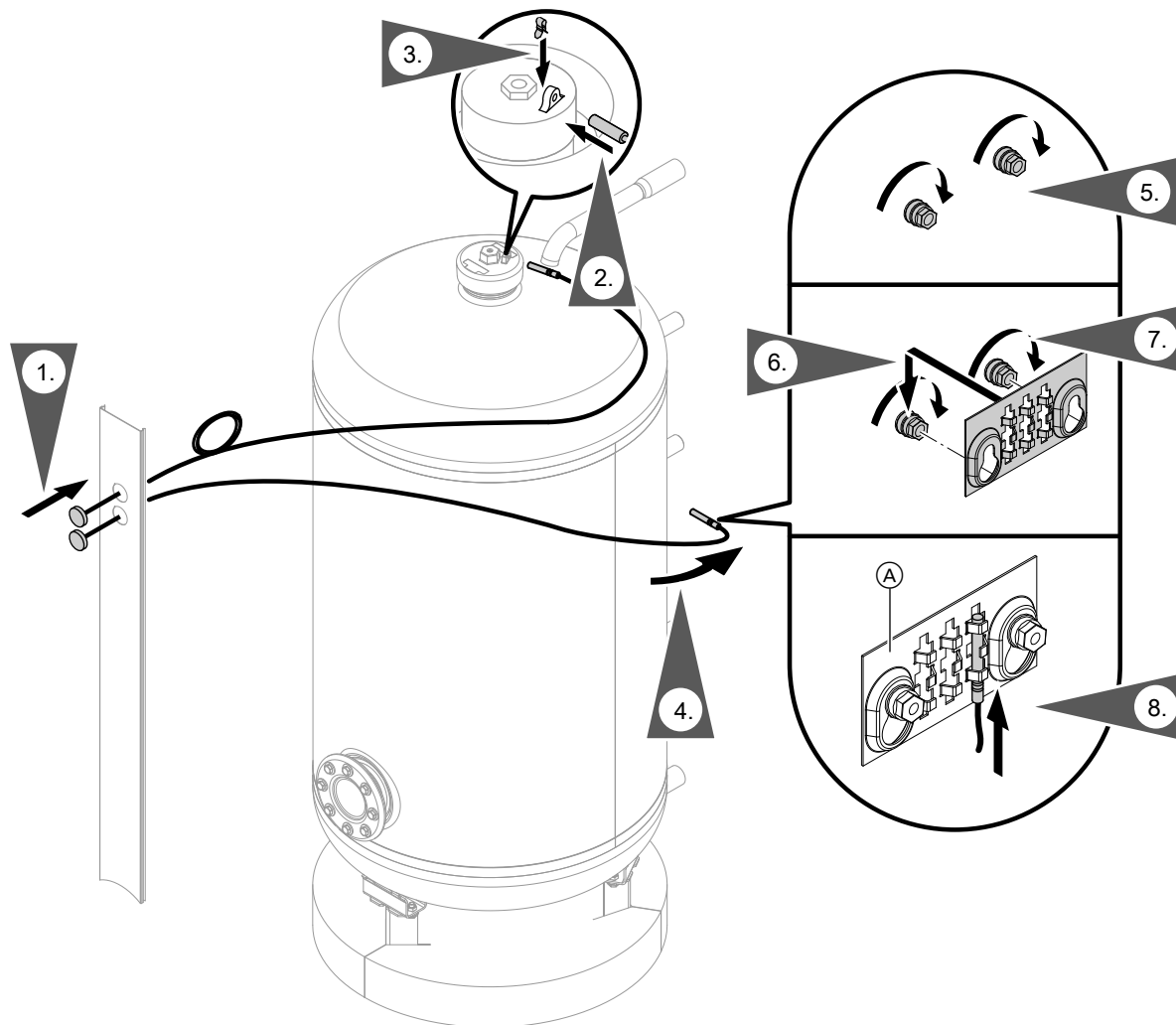

Fig. 10

1. Guide the thermometer sensor through the cover strip. Insert the thermometer.
- Note**  
The cover strip is held in its vertical position by the straight capillaries. This is necessary for the rest of the installation.
2. Insert the upper thermometer sensor as far as it will go into the hole in the cylinder cap.
  3. Use clips to secure the thermometer sensor against being pulled out.
  4. Route the bottom thermometer sensor capillaries to the back of the cylinder body.
  5. Screw the nuts onto the threaded studs. Do not tighten.
  6. Slot the clamping devices onto the threaded studs and align.
  7. Tighten the nuts.
  8. Depending on where the sensor is being fitted: Insert the **thermometer sensors** and **cylinder temperature sensor** into clamp (A) as far as they will go.
- Note**
- **Never wrap insulating tape around the sensors.**
  - **When the thermal insulation is being fitted, the cylinder temperature sensor leads are routed outwards through the apertures (slots) in the rear cover strip.**

Fitting the thermal insulation jacket

**Note**

- Ensure that no fleece remnants enter the DHW cylinder through the cylinder connections.
- 2 people are required for the following work.

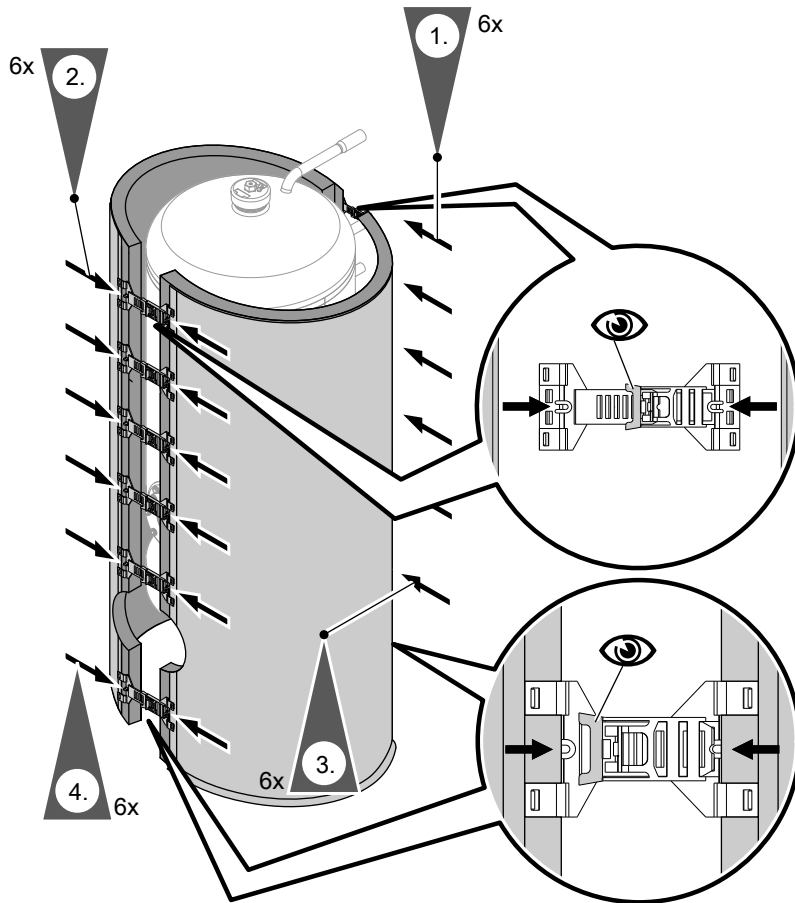

Fig. 11

1. At the back of the cylinder: Attach 6 clip fasteners to the edges of the right and left sections of the thermal insulation jacket. Place the thermal insulation jacket around the cylinder body.
3. Push the clip fasteners at the back of the cylinder as close together as possible.

**Note**

Leave the clip fasteners in the first notch.

2. At the front of the cylinder: Attach 6 clip fasteners to the edges of the right and left sections of the thermal insulation jacket.
4. Push the clip fasteners at the front of the cylinder as close together as possible.

## 500 l capacity (cont.)

## Fitting the cover strips

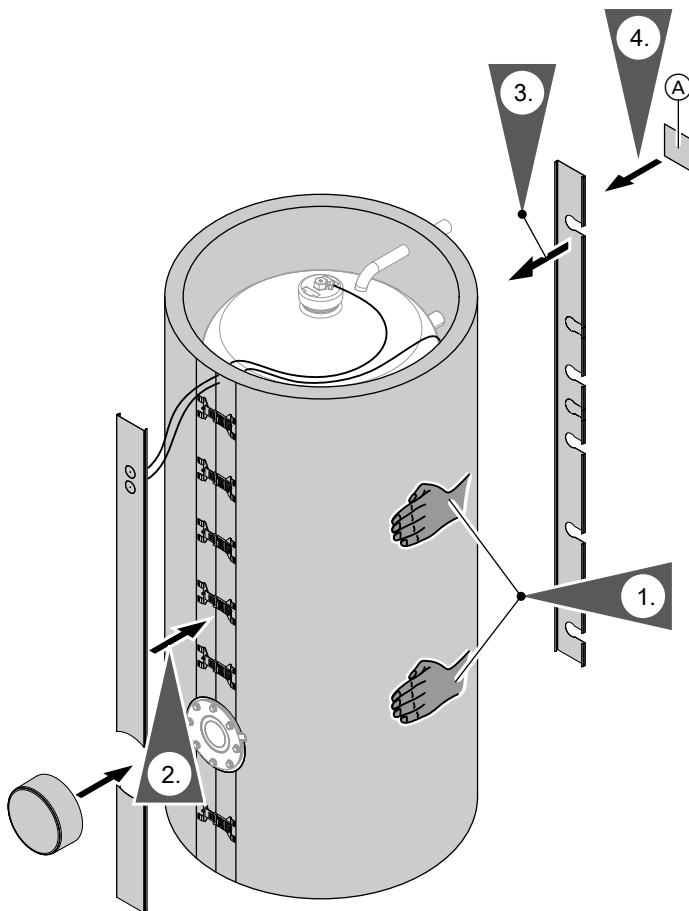

Fig. 12

(A) DHW cylinder type plate

1. Fit the thermal insulation jacket evenly around the cylinder body by patting it.
2. Mount the front cover strip and flange cover.
3. Fit the back cover strip.
4. Affix the type plate.

### Fitting the cover

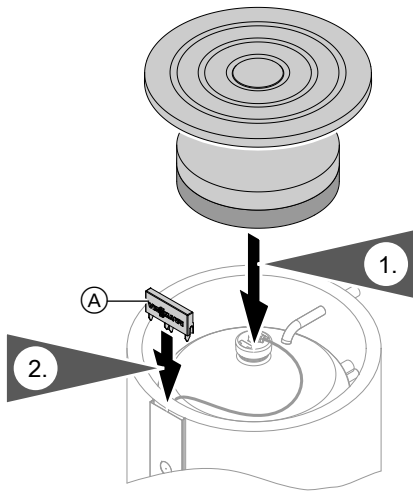

Fig. 13

Ⓐ Cap with Viessmann logo

#### Note

The soft side of the thermal insulation must rest against the cylinder body.

### Connections on the heating water side

- Connect all pipework with detachable fittings.
- Seal any connections that are not required with red brass caps.
- Adjust the temperature controller and high limit safety cut-out so that the DHW temperature in the DHW cylinder does not exceed 95 °C.

#### ! Please note

- The internal indirect coil is installed with gaskets.
  - Temperatures > 150 °C at the connections will damage the gaskets. Maintain a safe distance when soldering and welding.
  - Realigning the connector will damage the gaskets.

Permissible heating water flow temperature	
▪ Heating water side	160 °C
Permissible operating pressure	
▪ Heating water side	10 bar 1 MPa
▪ DHW side	10 bar 1 MPa
Test pressure	
▪ Heating water side	16 bar 1.6 MPa
▪ DHW side	16 bar 1.6 MPa
Permissible DHW temperature	95 °C



## Connections on the heating water side (cont.)

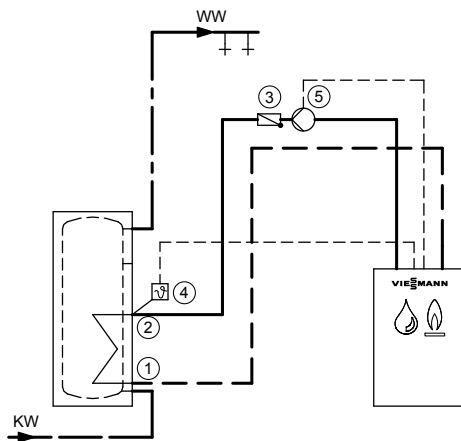

Fig. 14

- ① Heating water return
- ② Heating water flow
- ③ Spring-loaded check valve
- ④ Cylinder temperature sensor or temperature controller and high limit safety cut-out (if required)

- ⑤ Circulation pump
- KW Cold water
- WW DHW

1. For heating water flow temperatures in excess of 95 °C and cylinder capacity of 300 l: Remove the pipe collars from the pipe outlets on the heating water side.

**Note**

Pipe collars have l.h. threads.

2. Install the heat supply control unit.

3. Install the flow line with a rise and fit an air vent valve at the highest point.
4. Only for heating water flow temperatures in excess of 110 °C:  
If the system does not already have one, also install a type-tested high limit safety cut-out. For this, use a temperature limiter and high limit safety cut-out (TR/STB).

## Connections on the DHW side

- For connections on the DHW side, observe DIN 1988 and DIN 4753.  
Ⓢ: SVGW regulations.
- Connect all pipework with detachable fittings.
- Seal any connections that are not required with red brass caps.
- Equip the DHW circulation pipe with a DHW circulation pump and a check valve.
- Connection of the DHW circulation pump:
  - Connection to the boiler control unit if it is equipped with a DHW circulation pump connection.
  - Connection with a time switch if no DHW circulation pump connection is available on the boiler control unit.
  - Connection via time switch.
- Always install cylinder banks with connected DHW circulation.

**Please note**

The internal indirect coil is installed with gaskets.

- Temperatures > 150 °C at the connections will damage the gaskets.  
Maintain a safe distance when soldering and welding.
- Realigning the connector will damage the gaskets.

## Connections on the DHW side (cont.)

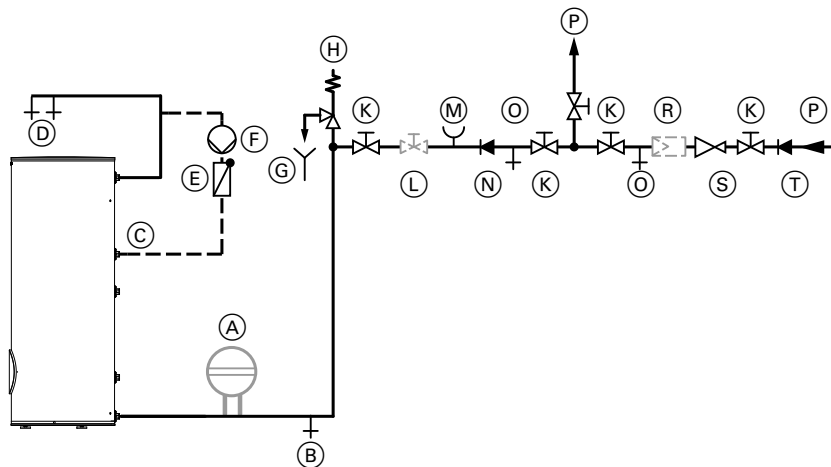

Fig. 15 Example: 300 l capacity

- |   |                                     |
|---|-------------------------------------|
| (A) Diaphragm expansion vessel          | (L) Flow regulating valve           |
| (B) Drain                               | (M) Pressure gauge connector        |
| (C) DHW circulation pipe                | (N) Non-return valve                |
| (D) DHW                                 | (O) Drain                           |
| (E) Spring-loaded check valve           | (P) Cold water                      |
| (F) DHW circulation pump                | (R) Drinking water filter           |
| (G) Visible discharge pipe outlet point | (S) Pressure reducer                |
| (H) Safety valve                        | (T) Non-return valve/pipe separator |
| (K) Shut-off valve                      |                                     |

## Safety valve

The system must be equipped with a type-tested diaphragm safety valve as protection against overpressure.

Permissible operating pressure: 10 bar (1 MPa).

The connection diameter of the safety valve must be as follows:

- Up to 200 l capacity  
min. R ½ (DN 15),  
max. heat input 75 kW
- Between 200 and 1000 l capacity  
min. R ¾ (DN 20),  
max. heat input 150 kW
- Between 1000 and 5000 l capacity  
min. R 1 (DN 25),  
max. heat input 250 kW

Select a safety valve with a higher rating if the heat input of the DHW cylinder is greater than the maximum heat input assigned to the capacity. (See DIN 4753-1, issue 3/88, section 6.3.1).

Install the safety valve in the cold water line. It must not be able to be isolated from the DHW cylinder or the cylinder bank. There must be no constrictions in the pipework between the safety valve and the DHW cylinder.

Never seal off the safety valve discharge pipe. The overpressure can damage the system. Ensure that any expelled water is safely and visibly drained into a drainage system. Position a sign close to the safety valve discharge pipe, or ideally on the safety valve itself, with the following inscription:

"For safety reasons, water may be discharged from the discharge pipe during heating! Do not seal off!"

Recommendation: Install the safety valve above the top edge of the DHW cylinder. Then the DHW cylinder will not need to be drained when working on the safety valve.

## Connecting the DHW circulation pipe for cylinder banks

### Note

Always install cylinder banks with connected DHW circulation.

Connecting the DHW circulation pipe for... (cont.)

Notes on the diagrams below

- Headers (D) for DHW must be approved for drinking water.
- Install the temperature controller in the final cylinder, as viewed from the heating water flow.
- The "DHW" connection can, contrary to the diagrams, also be connected on the same side as the heating water flow, and the "cold water" connection can be implemented on the same side as the heating water return. This ensures that every cylinder is heated and that water is drawn off from every cylinder equally.

In conjunction with boilers or district heating systems without heating water return temperature limiting facility and a DHW circulation pipe

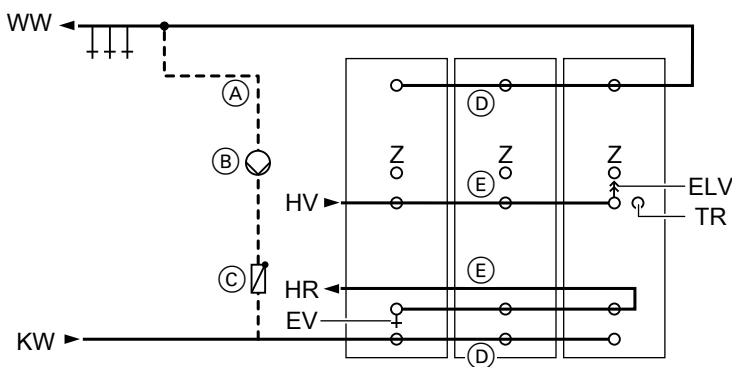

Fig. 16

- |  |                           |
|--|---------------------------|
| (A) DHW circulation pipe                     | HR Heating water return   |
| (B) DHW circulation pump                     | HV Heating water flow     |
| (C) Spring-loaded check valve                | KW Cold water             |
| (D) Header on the DHW side (stainless steel) | WW DHW                    |
| (E) Header on the heating water side (steel) | TR Temperature controller |
| ELV Air vent valve                           | Z DHW circulation         |
| EV Drain valve                               |                           |

In conjunction with district heating systems with a return temperature limiting facility on the heating water side and/or in conjunction with several DHW circulation pipes

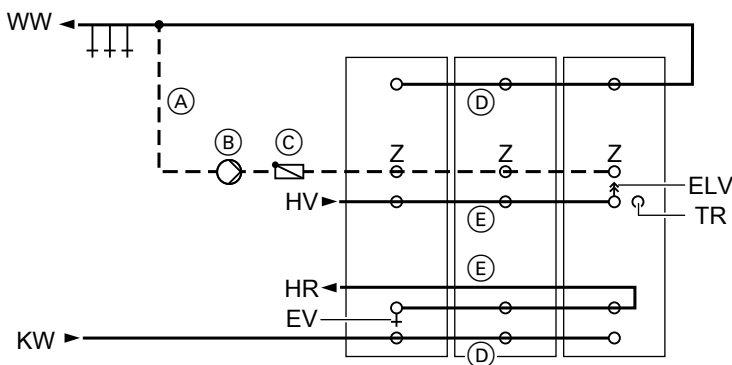

Fig. 17

- |  |                         |
|--|-------------------------|
| (A) DHW circulation pipe                     | ELV Air vent valve      |
| (B) DHW circulation pump                     | EV Drain valve          |
| (C) Spring-loaded check valve                | HR Heating water return |
| (D) Header on the DHW side (stainless steel) | HV Heating water flow   |
| (E) Header on the heating water side (steel) | KW Cold water           |

## Installation sequence

### Connecting the DHW circulation pipe for... (cont.)

WW DHW  
TR Temperature controller  
Z DHW circulation

### Connecting the equipotential bonding

Connect the equipotential bonding in accordance with TAR medium voltage VDE-AR-N-4100 of the local power supply utility and VDE regulations.

**CH:** Connect the equipotential bonding in accordance with the technical requirements stipulated by the local power supply utility and SEV regulations.



**Steps - commissioning, inspection and maintenance**

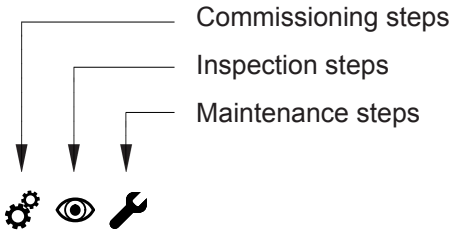

Page

<ul style="list-style-type: none"> <li>•</li> <li>•</li> <li>•</li> <li>•</li> <li>•</li> </ul>	<ul style="list-style-type: none"> <li>•</li> <li>•</li> <li>•</li> <li>•</li> <li>•</li> </ul>	<ul style="list-style-type: none"> <li>•</li> <li>•</li> <li>•</li> <li>•</li> <li>•</li> </ul>	<ul style="list-style-type: none"> <li><b>1. Filling the DHW cylinder..... 22</b></li> <li><b>2. Shutting down the system</b></li> <li><b>3. Checking the safety valve function</b></li> <li><b>4. Cleaning the inside of the DHW cylinder..... 22</b></li> <li><b>5. Reassembling the DHW cylinder..... 24</b></li> <li><b>6. Checking the connections on the water side for tightness</b></li> </ul>
---	---	---	--



   **Filling the DHW cylinder**

1. Fill the DHW cylinder on the DHW side.

**Note**

*If the DHW cylinder is pressurised, tighten the flange cover with a torque of 40 Nm.  
The cylinder cap does **not** need to be retightened.*

2. Check the fittings on the heating water and DHW sides for leaks and tighten if required.

3. Check the function of the safety valves according to the manufacturer's instructions.

   **Shutting down the system**

   **Checking the safety valve function**

   **Cleaning the inside of the DHW cylinder**

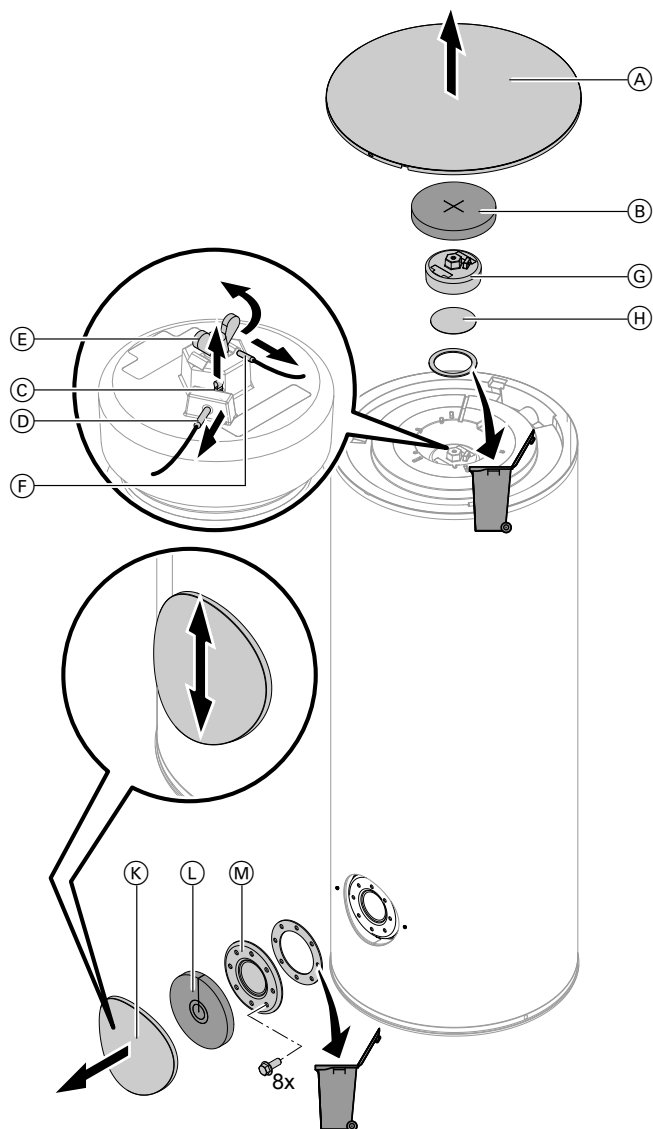

Fig. 18 160 to 300 l capacity

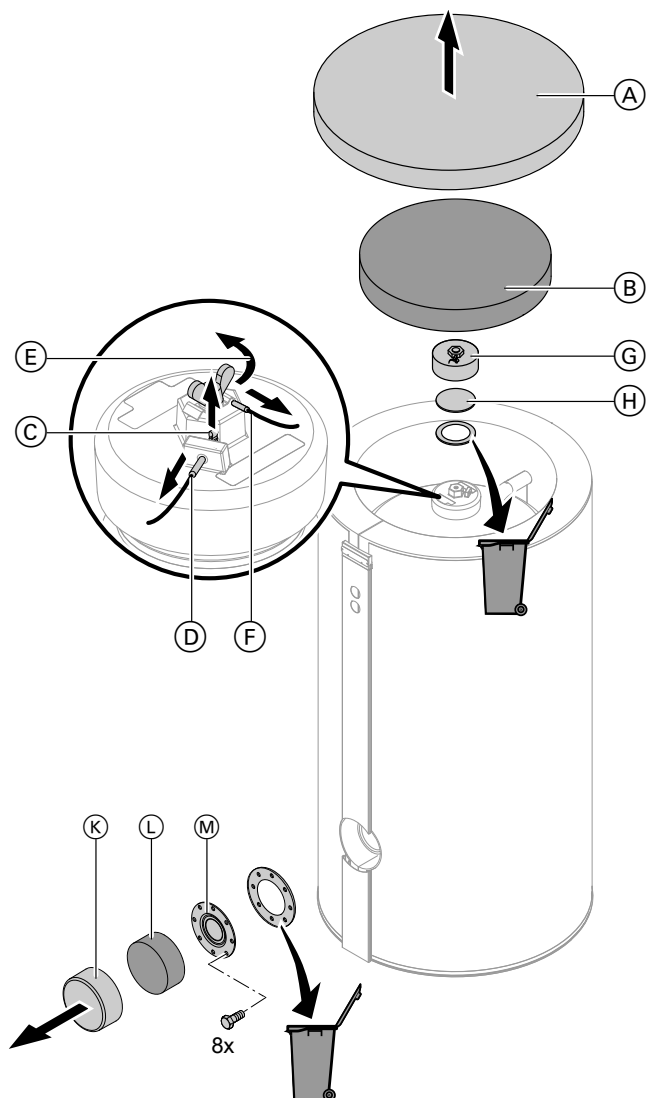

Fig. 19 500 l capacity

1. Remove cover (A) and thermal insulation (B).



## Cleaning the inside of the DHW cylinder (cont.)

2. If present, remove spring clip (C). Pull out thermometer sensor (D).
3. Undo wing nut (E). Pull out the sensor for high limit safety cut-out (F).
4. Remove cylinder cap (G) and stainless steel circular blank (H).
5. Drain the DHW cylinder on the DHW side.
6. Remove cap (K), thermal insulation (L) and flange cover (M).
7. Disconnect the DHW cylinder from the pipework to prevent cleaning agents and contaminants from entering the pipework.
8. **!** **Please note**  
Pointed, sharp and hard objects can damage the interior of the cylinder.  
Only use plastic tools to clean the interior.

Remove loose deposits with a high pressure cleaner or manually.

9. **!** **Danger**  
Cleaning agent residues can lead to **poisoning**.  
Observe the cleaning agent manufacturer's instructions.

**!** **Please note**  
Cleaning agents containing hydrochloric acid can damage the inside of the cylinder.  
Never use cleaning agents containing hydrochloric acid.

Use a chemical cleaning agent to remove hard deposits that cannot be removed with a high pressure cleaner.

10. **Fully** drain all cleaning agent.
11. Flush the DHW cylinder **thoroughly** after cleaning.





## Reassembling the DHW cylinder

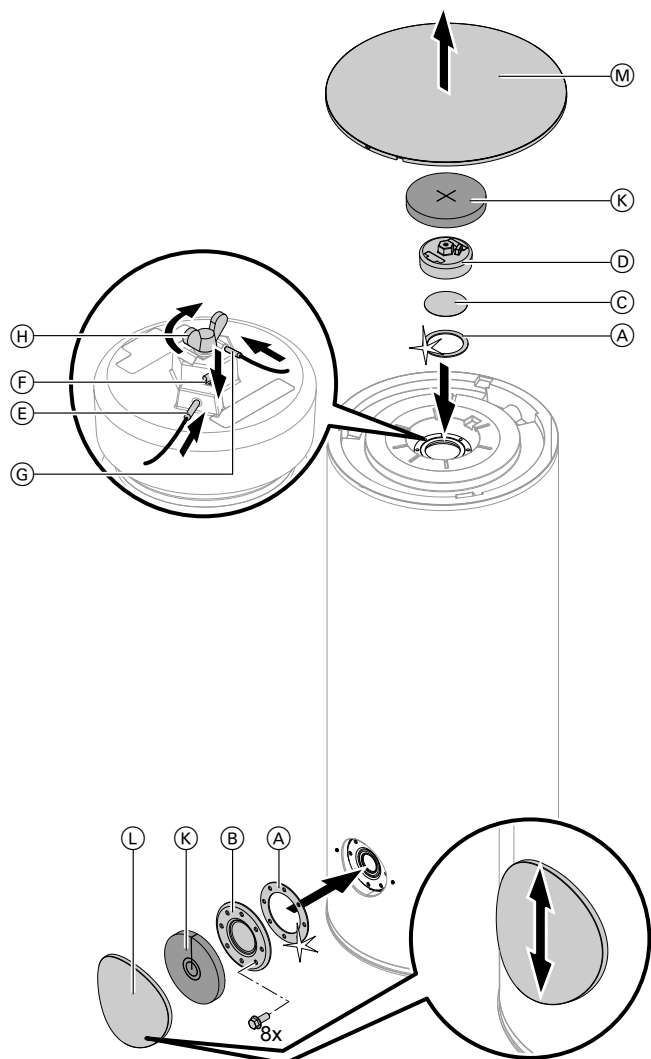

Fig. 20 160 to 300 l capacity

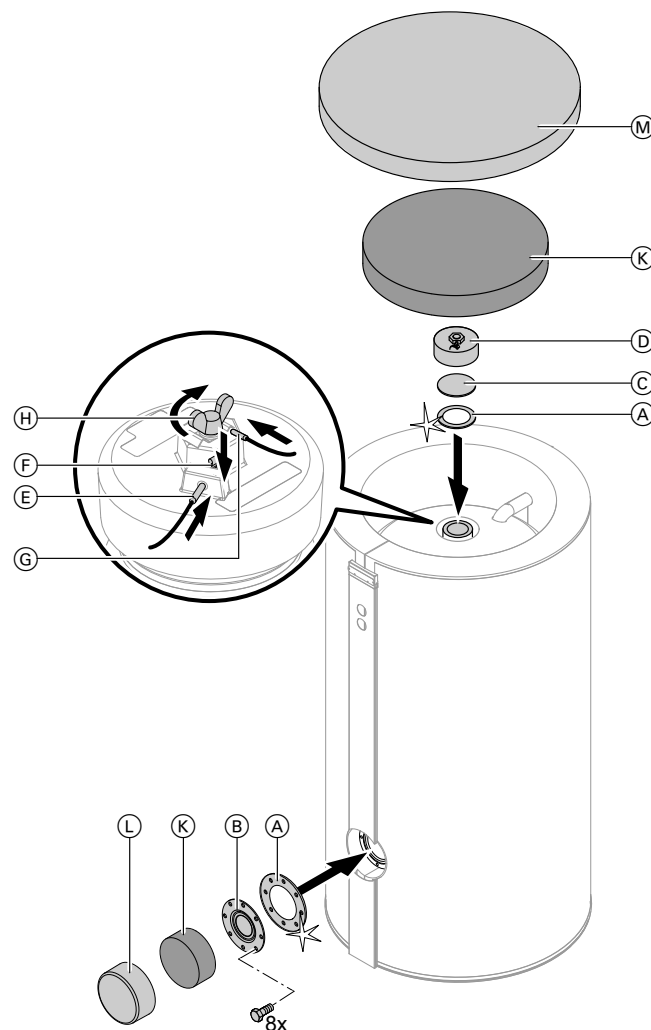

Fig. 21 500 l capacity

1. Reconnect the DHW cylinder to the pipework.
2. Insert **new** gaskets (A).
3. Fit flange cover (B).  
Max. torque: 40 Nm
4. Refit stainless steel circular blank (C) and cylinder cap (D).  
Max. torque: 160 Nm
5. Fill the DHW cylinder on the DHW side.
6. Retighten all flange covers (B).  
Max. torque: 40 Nm
7. If present, insert thermometer sensor (E) and secure with spring clip (F).
8. Insert high limit safety cut-out sensor (G) and secure with wing nut (H).
9. Fit thermal insulation (K), cap (L) and cover (M).





**Checking the connections on the water side for tightness**



Commissioning/service reports

**Commissioning/service reports**

	<b>Commissioning</b>	<b>Maintenance/service</b>	<b>Maintenance/service</b>
Date:			
By:			

	<b>Maintenance/service</b>	<b>Maintenance/service</b>	<b>Maintenance/service</b>
Date:			
By:			

	<b>Maintenance/service</b>	<b>Maintenance/service</b>	<b>Maintenance/service</b>
Date:			
By:			

	<b>Maintenance/service</b>	<b>Maintenance/service</b>	<b>Maintenance/service</b>
Date:			
By:			

	<b>Maintenance/service</b>	<b>Maintenance/service</b>	<b>Maintenance/service</b>
Date:			
By:			

## Specification

## Vitocell 300-V/-W, type EVIB-A+, EVIB-A and EVIA-A

Type		EVIB-A+		EVIB-A			EVIA-A
<b>Cylinder capacity</b> (AT: Actual water capacity)	l	160	200	160	200	300	500
<b>Heating water capacity</b>	l	7.4		7.4		11.0	12.9
<b>Gross volume</b>	l	167.4	207.4	167.4	207.4	311.0	512.9
<b>DIN registration number</b>		Applied for					9W71-10MC /E
<b>Continuous output</b> at heating water flow rate stated below							
▪ For DHW heating from <b>10 to 45 °C</b> and the following <b>heating water</b> flow temperatures							
	90 °C	kW		46	46	61	69
		l/h		1127	1127	1501	1688
	80 °C	kW		38	38	51	58
		l/h		939	939	1252	1414
	70 °C	kW		30	30	41	46
		l/h		747	747	998	1128
	60 °C	kW		22	22	30	34
		l/h		547	547	733	830
	50 °C	kW		13	13	18	20
		l/h		322	322	434	491
▪ For DHW heating from <b>10 to 60 °C</b> and the following <b>heating water</b> flow temperatures							
	90 °C	kW		39	39	52	59
		l/h		668	668	894	1011
	80 °C	kW		31	31	41	46
		l/h		527	527	706	799
	70 °C	kW		22	22	29	33
		l/h		372	372	501	568
<b>Heating water flow rate</b> for the stated continuous outputs	m <sup>3</sup> /h	3.0		3.0		3.0	3.0
<b>Standby heat loss</b>	kWh/ 24 h	0.71	0.75	0.98	1.04	1.18	1.37
<b>Permissible temperatures</b>							
▪ Heating water side	°C	160	160	160	160	160	160
▪ DHW side	°C	95	95	95	95	95	95
<b>Permissible operating pressure</b>							
▪ Heating water side	bar	10	10	10	10	10	10
	MPa	1	1	1	1	1	1
▪ DHW side	bar	10	10	10	10	10	10
	MPa	1	1	1	1	1	1

## Specification

### Specification (cont.)

Type		EVIB-A+		EVIB-A			EVIA-A
<b>Cylinder capacity</b> (AT: Actual water capacity)	l	160	200	160	200	300	500
<b>Dimensions</b>							
Length a (Ø)							
▪ Incl. thermal insulation	mm	634	634	634	634	668	1022
▪ Excl. thermal insulation	mm	—	—	—	—	—	715
Width b							
▪ Incl. thermal insulation	mm	661	661	661	661	706	1084
▪ Excl. thermal insulation	mm	—	—	—	—	—	954
Height c							
▪ Incl. thermal insulation	mm	1190	1410	1190	1410	1740	1852
▪ Excl. thermal insulation	mm	—	—	—	—	—	1667
Height when tilted							
▪ Incl. thermal insulation	mm	1323	1520	1323	1520	1840	—
▪ Excl. thermal insulation	mm	—	—	—	—	—	1690
<b>Total weight</b> incl. thermal insulation	kg	57	65	57	65	92	110
<b>Heating surface</b>	m <sup>2</sup>	1.0		1.0		1.5	1.7
<b>Connections</b> (male thread)							
Heating water flow and return	R	1		1		1	1
Cold water, DHW	R	¾		¾		1	1¼
DHW circulation	R	¾		¾		1	1
<b>Energy efficiency class</b>		A+		A		A	A
<b>Colour of the Vitocell 300-V</b>							
▪ Vitosilver		X	X	X	X	X	X
▪ Vitoppearlwhite		—	—	—	—	—	X
▪ Vitographite		—	—	X	X	—	—
<b>Colour of the Vitocell 300-W</b>							
▪ Vitoppearlwhite		X	X	X	X	X	—

### Specification for immersion heater EHE in conjunction with Vitocell 300-V/-W

Type		EVIB-A	EVIA-A
<b>Cylinder capacity</b>	l	300	500
<b>Content that can be heated by the immersion heater EHE</b>	l	256	390
<b>Width</b> incl. immersion heater EHE	mm	830	1103
<b>Minimum wall clearance</b> for installation of the immersion heater EHE	mm	730	670
<b>Heat-up time</b> from 10 to 60 °C with immersion heater EHE:			
▪ 2 kW	h	7.3	11.4
▪ 4 kW	h	3.6	5.7
▪ 6 kW	h	2.4	3.8

### Specification – immersion heater EHE

<b>Output range</b>	kW	Max. 6		
<b>Rated consumption</b> standard mode/quick heat-up	kW	2	4	6
<b>Rated voltage</b>		3/N/PE 400 V/50 Hz		
<b>Rated current</b>	A	8.7	17.4	8.7
<b>Weight</b>	kg	2	2	2
<b>IP rating</b>		IP 45		

## Final decommissioning and disposal

Viessmann products can be recycled. Components and substances from the system are not part of ordinary domestic waste.

For decommissioning, isolate the system from the power supply and allow components to cool down where appropriate.  
All components must be disposed of correctly.

## Certificates

### Declaration of conformity

We, Viessmann Climate Solutions SE, D-35108 Allendorf, declare as sole responsible body that the named product complies with the European directives and supplementary national requirements in terms of its design and operational characteristics.

Using the serial number, the Declaration of Conformity can be found on the following website:  
**[www.viessmann.co.uk/eu-conformity](http://www.viessmann.co.uk/eu-conformity)**

**Keyword index**

<b>C</b>		<b>P</b>	
Connections.....	8	Product information.....	6
Cylinder temperature sensor.....	10, 13		
<b>D</b>		<b>S</b>	
DHW connections.....	17	Safety valve.....	18
		Siting.....	8
		Specification.....	27
<b>H</b>		<b>T</b>	
Heating water side connection.....	16	Thermal insulation.....	14
		Thermometer sensor.....	10, 13
<b>I</b>			
Intended use.....	5		

Viessmann Climate Solutions SE  
35108 Allendorf / Germany  
Telephone: +49 6452 70-0  
Fax: +49 6452 70-2780  
[www.viessmann.com](http://www.viessmann.com)



Viessmann Limited  
Hortonwood 30, Telford  
Shropshire, TF1 7YP, GB  
Telephone: +44 1952 675000  
Fax: +44 1952 675040  
E-mail: [info-uk@viessmann.com](mailto:info-uk@viessmann.com)

6173387 Subject to technical modifications.