

Technical guide



DHW heating

Central DHW heating

- With Viessmann DHW cylinders
- With Viessmann cylinder loading system
- With Viessmann freshwater module

Index

1. Sizing systems for DHW heating	1.1 Principles	4
	■ General	4
	■ Irregular DHW demand	4
	■ Constant DHW demand	4
	■ High DHW demand	4
	■ Heating systems with special requirements for return temperatures	4
	■ Calculation program	4
	■ Hydraulic connection	4
2. Product information	2.1 Product description	5
	■ Vitocell 100-H, type CHA/CHAA	5
	■ Vitocell 300-H, type EHA/EHAA	5
	■ Vitocell 100-V, type CVA/CVAA/CVAB/CVAB-A	5
	■ Vitocell 100-V, type CVWB/CVWC	5
	■ Vitocell 300-V, type EVIB-A/EVIA-A/EVIB-A+	6
	■ Vitocell 100-W, type CUGB/CUGB-A	6
	■ Vitocell 100-L, type CVL/CVLA and Vitotrans 222	6
	■ Vitocell 100-B, type CVB/CVBB/CVBC	6
	■ Vitocell 100-U, type CVUD/CVUD-A	6
	■ Vitocell 300-B, type EVBA-A/EVBB-A	7
	■ Vitocell 320-M, type SVHA and Vitocell 340-M, type SVKA, SVKC and Vitocell 360-M, type SVSB	7
	■ Vitotrans 353 (freshwater module)	7
	2.2 Overview of product features	8
	2.3 Intended use of Viessmann cylinders and Vitotrans	8
3. Selecting the cylinder type	3.1 Selection according to N_L factor	9
	■ General information	9
	■ DHW cylinder selection	9
	■ Selection diagrams, cylinder loading system Vitocell 100-L, type CVLA, with Vitotrans 222	13
	3.2 Selection according to continuous output	14
4. Sizing	4.1 Sizing according to peak draw-off rate and DIN 4708-2	15
	■ Application	15
	■ Calculating the heat demand for DHW heating in residential buildings	15
	■ Calculating the applicable draw-off demand per draw-off point to be considered	16
	■ Calculating the demand factor N	16
	■ Boiler supplement Z_K	18
	■ Calculating the heat demand for DHW heating in commercial enterprises	19
	■ Calculating the heat demand for DHW heating in hotels, guest houses and residential homes	19
	■ Calculating the heat demand for DHW heating in commercial saunas	20
	■ Calculating the heat demand for DHW heating for sports halls	21
	4.2 Sizing according to peak flow rate with reference to DIN 1988-300	23
	■ Application	23
	■ Calculating the DHW demand	23
	■ Calculating the required buffer volume	24
	4.3 Sizing according to continuous output	25
	■ Application	25
	■ Determining the required DHW cylinder, example 1 (with constant flow temperatures)	25
	■ Determining the required DHW cylinder, example 2 (with a fixed heat generator temperature differential)	25
5. Cylinder loading systems — Vitocell 100-L with Vitotrans 222	5.1 Applications and advantages	28
	5.2 Function description of the cylinder loading system	29
	■ Operation with modulating flow temperature	29
	■ Operation with constant flow temperature	29
	■ Operation with a heat pump in conjunction with a heating lance for DHW heating	30
	5.3 General formulas for calculating the cylinder loading system	32
	■ Calculation based on water volume	32
	■ Calculation based on heat volume	32
	5.4 Sample calculation	33
	■ Calculation of the cylinder size based on water volume	33
	■ Calculation of the cylinder size based on heat volume	33
6. Installation — DHW cylinders	6.1 Connection on the DHW side	34

	■ General information	34
	■ Vitocell 100-H and Vitocell 300-H	35
	■ Vitocell 100-V and Vitocell 300-V	35
	■ Cylinder banks with Vitocell 300-H	36
	■ Vitotrans 222 (accessories) in conjunction with a Vitocell 100-L	37
6.2	DHW circulation pipes	38
6.3	Preventing corrosion damage	39
	■ Interaction between water and materials	39
	■ Water temperature	39
	■ Introduction of dirt	39
	■ Pipework	39
	■ DHW cylinders made from stainless steel	40
	■ DHW cylinders made from steel with Ceraprotect enamel coating and cathodic corrosion protection	40
	■ Plate heat exchangers made from stainless steel, copper brazed	40
	■ Note	41
7.	Appendix	
7.1	Questionnaire regarding the sizing of DHW cylinders	42
	■ DHW cylinders in DHW heating systems	42
7.2	Checklist for heat exchanger enquiries/sizing	44
	■ Intended use: Water/water	44
7.3	Checklist for heat exchanger enquiries/sizing	45
	■ Intended use: Steam/water	45
8.	Keyword index	46

Sizing systems for DHW heating

1.1 Principles

General

When sizing DHW heating systems, 2 main principles must be taken into consideration: For hygiene reasons, size the volume of the DHW heating system so that it is as small as possible. However, for reasons of convenience, it should be as large as required. This means that the system must be designed as accurately as possible.

In practice, various approaches are taken:

- For residential buildings, sizing is often carried out to **DIN 4708 Part 2**. Taking into account the sanitary amenities of the individual apartments/residential units, the number of occupants/users and utilisation factors, the demand factor N can be determined.
- Systems operating according to the instantaneous water heater principle, e.g. freshwater modules, may also be sized according to peak flow rate (max. flow rate) with reference to DIN 1988-300.

Irregular DHW demand

Examples:

- Schools
- Trading estates
- Hotels
- Sports complexes with shower units

For buildings with irregular DHW demand, sizing is frequently carried out based on the **peak output**/max. draw-off rate over 10 minutes. The DHW heating system should not be oversized, but at the same time, it is also essential to consider the heat-up time for the DHW cylinder until the next peak in demand occurs. The available heating and transfer output must be enough to ensure that the DHW can be adequately heated in the time between the peaks in demand.

Constant DHW demand

Examples:

- Food processing plants
- Swimming baths

For applications with a constant DHW demand, the DHW heating system is sized based on the constant demand of the consumer (continuous output). The size of the heat exchanger and the available heating output are crucial factors.

High DHW demand

Example:

- Cylinder loading systems

For extremely high DHW demand, the DHW heating system is sized according to both the peak output and the continuous output.

Heating systems with special requirements for return temperatures

Example:

- District heating systems

If special consideration must be given to the return temperatures of the heating system, it is practical to size it according to the **continuous output**.

Calculation program

See <https://cylinder-planner.ca.viessmann.com>.

Hydraulic connection

The following are important for safe and reliable operation of the DHW heating system:

- Sizing of the DHW cylinder
- Hydraulic connection of the DHW cylinder
- Overall system operation

Regulations and directives to be specifically observed:

- DVGW Code of Practice W 551
- TRWI (DIN 1988)
- Valid Drinking Water Ordinance [Germany] (TrinkwV)
- Directive 98/83/EC of the Council of the European Union

The following are important for hygienic operation of the DHW heating system:

- Correct operating temperature
- Design of the DHW circulation pipe
- Connection of the DHW circulation pipe to the DHW cylinder

Product information

2.1 Product description

Vitocell 100-H, type CHA/CHAA

130, 160 and 200 l capacity, horizontal, enamelled, internal indirect coil

Horizontal DHW cylinder with internal indirect coil.

Cylinder and internal indirect coil made from steel, corrosion protection through Ceraprotect enamel coating and protective magnesium anode.

The DHW cylinders feature all-round thermal insulation and are enclosed within an epoxy-coated sheet steel casing.

Colour

- Vitosilver:
Type CHA 130, 160, 200 l
- Vitographite:
Type CHAA 130, 160, 200 l

Vitocell 300-H, type EHA/EHAA

160, 200, 350 and 500 l capacity, horizontal, made from stainless steel, internal indirect coil

Horizontal DHW cylinder made from stainless steel with internal indirect coil.

The DHW cylinders feature all-round thermal insulation and are enclosed within an epoxy-coated sheet steel casing.

Colour

- Vitosilver:
Type EHA 160, 200, 350, 500 l
- Vitographite:
Type EHAA 160, 200 l

Cylinder banks

The Vitocell 300-H with 350 and 500 l capacity can be combined on site with manifolds for the heating water and DHW sides to form cylinder banks (700 l, 1000 l, 1500 l).

Vitocell 100-V, type CVA/CVAA/CVAB/CVAB-A

160, 200, 300, 500, 750 and 950 l capacity, vertical, enamelled, internal indirect coil

Vertical DHW cylinder with internal indirect coil.

Cylinder and internal indirect coil made from steel, corrosion protection through Ceraprotect enamel coating and protective magnesium anode.

The DHW cylinders feature all-round thermal insulation.

- **160, 200 and 300 l**
With epoxy-coated sheet steel casing
- **500, 750 and 950 l**
The removable thermal insulation is supplied separately.

Colour

- Vitosilver:
Type CVAA 160, 200, 750, 950 l
Type CVAB-A 160, 200 l
Type CVAB 300 l
Type CVA 500 l
- Vitopearlwhite:
Type CVAA/CVAB-A 160, 200 l
Type CVAB 300 l
Type CVA 500 l
- Vitographite:
Type CVAA 160, 200 l

Cylinder banks

The Vitocell 100-V with 300 and 500 l capacity can be combined with manifolds for the heating water and DHW sides (accessories) to form cylinder banks.

Vitocell 100-V, type CVWB/CVWC

200, 250, 300, 390 and 500 l capacity, vertical, enamelled, internal indirect coil

Vertical DHW cylinder with large internal indirect coil, especially for DHW heating in conjunction with heat pumps.

Cylinder and internal indirect coil made from steel, corrosion protection through Ceraprotect enamel coating and protective magnesium anode.

The DHW cylinders feature all-round thermal insulation.

- **200, 250 and 300 l**
With epoxy-coated sheet steel casing
- **390 and 500 l**
The removable thermal insulation is supplied separately.

Colour

- Vitopearlwhite:
Type CVWC 200, 250, 300 l
Type CVWB 390, 500 l

Vitocell 300-V, type EVIB-A/EVIA-A/EVIB-A+

160, 200, 300 and 500 l capacity, vertical, made from stainless steel, internal indirect coil

Vertical DHW cylinder made from stainless steel with internal indirect coil.

The DHW cylinders feature all-round thermal insulation.

■ 160, 200 and 300 l

With epoxy-coated sheet steel casing

■ 500 l

The removable thermal insulation is supplied separately.

Colour

■ Vitosilver:

Type EVIB-A 160, 200, 300 l

Type EVIB-A+ 160, 200 l

Type EVIA-A 500 l

■ Vitoppearlwhite:

Type EVIB-A 160, 200, 300 l

Type EVIB-A+ 160, 200 l

Type EVIA-A 500 l

■ Vitographite:

Type EVIB-A 160, 200 l

Cylinder banks

The Vitocell 300-V with 300 and 500 l capacity can be combined with manifolds for the heating water and DHW sides (accessories) to form cylinder banks.

Vitocell 100-W, type CUGB/CUGB-A

120 and 150 l capacity, vertical, enamelled, internal indirect coil

Vertical DHW cylinder with internal indirect coil especially for installation below a wall mounted gas boiler. Cylinder and internal indirect coil made from steel, corrosion protection through Ceraprotect enamel coating and protective magnesium anode.

The DHW cylinders feature all-round thermal insulation and are enclosed within an epoxy-coated sheet steel casing.

Colour

■ Vitoppearlwhite:

Type CUGB and CUGB-A 120, 150 l

Vitocell 100-L, type CVL/CVLA and Vitotrans 222

500, 750 and 950 l capacity, cylinder loading system, enamelled

Vertical DHW cylinder for connecting an external heat exchanger set.

Steel loading cylinder, Ceraprotect enamel coating and protective magnesium anode for anti-corrosion protection.

The loading cylinders feature all-round thermal insulation. The removable thermal insulation is supplied separately.

Colour

■ Vitosilver:

Type CVL 500, 1500, 2000 l

Vitotrans 222

Heat exchanger set comprising plate heat exchanger with thermal insulation, cylinder loading pump, heating water pump and line regulating valve.

Vitocell 100-B, type CVB/CVBB/CVBC

300, 400, 500, 750 and 950 l capacity, vertical, enamelled, for solar DHW heating

Vertical DHW cylinder with 2 internal indirect coils for dual mode DHW heating.

Cylinder and internal indirect coil made from steel, corrosion protection through Ceraprotect enamel coating and protective magnesium anode.

The DHW cylinders feature all-round thermal insulation.

■ 300 l

With epoxy-coated sheet steel casing

■ 400, 500, 750 and 950 l

The removable thermal insulation is supplied separately.

Colour

■ Vitosilver:

Type CVBC 300 l

■ Vitoppearlwhite:

Type CVBC 300 l

Type CVB 400, 500 l

Type CVBB 750, 950 l

Vitocell 100-U, type CVUD/CVUD-A

300 l capacity, vertical, enamelled, for solar DHW heating

Vertical DHW cylinder with 2 internal indirect coils for dual mode DHW heating.

Cylinder and internal indirect coil made from steel, corrosion protection through Ceraprotect enamel coating and protective magnesium anode.

The DHW cylinders feature all-round thermal insulation and are enclosed within an epoxy-coated sheet steel casing.

■ Type CVUD

With fitted Solar-Divicon and Vitosolic 100 solar control unit, type SD1, or electronics module SDIO/SM1A

■ Type CVUD-A

With fitted Solar-Divicon and electronics module SDIO/SM1A

Product information (cont.)

Colour

- Vitosilver:
Type CVUD 300 I
- Vitopearlwhite:
Type CVUD 300 I
Type CVUD-A 300 I

Vitocell 300-B, type EVBA-A/EVBB-A

300, 500 l capacity, vertical, made of stainless steel, for solar DHW heating

Vertical DHW cylinder made of stainless steel, with 2 internal indirect coils for dual mode DHW heating.

The DHW cylinders feature all-round thermal insulation.

- 300 l
With epoxy-coated sheet steel casing
- 500 l
The removable thermal insulation is supplied separately.

Colour

- Vitosilver:
Type EVBB-A 300 I
- Vitopearlwhite:
Type EVBB-A 300 I
Type EVBA-A 500 I

Vitocell 320-M, type SVHA and Vitocell 340-M, type SVKA, SVKC and Vitocell 360-M, type SVSB

400, 750, 910 and 950 l capacity

Multi mode heating water buffer cylinder for hygienic DHW heating in continuous operation with internal indirect coil made from a high alloy corrugated stainless steel pipe.

The DHW cylinders feature all-round thermal insulation. The removable thermal insulation is supplied separately.

Vitocell 320-M:

- Without solar indirect coil

Vitocell 340-M:

- With a solar indirect coil for solar DHW heating and central heating backup

Vitocell 360-M:

- With a solar indirect coil for solar DHW heating and central heating backup
- With stratification system for stratification of solar heat in relation to temperature.

Colour

- Vitosilver:
Type SVKC 750, 950 I
Type SVSB 750, 950 I
- Vitopearlwhite:
Type SVKA 400 I
Type SVKC 750, 950 I
Type SVSB 750, 950 I
Type SVHA 750, 910 I
- Vitographite:
Type SVKA 400 I
Type SVKC 750, 950 I
Type SVSB 750, 950 I
Type SVHA 750, 910 I

Vitotrans 353 (freshwater module)

Draw-off rate 25 l/min, 48 l/min, 68 l/min

Note

Draw-off rate in line with SPF test procedure, performance factor 1 (PF 1): See Vitotrans 353 datasheet.

Freshwater module for hygienic DHW heating in accordance with the instantaneous water heating principle.

Available for wall mounting as type PBSA, PBMA/PBMA-S and PBLA/PBLA-S or as type PZSA and PZMA/PZMA-S for installation on heating water buffer cylinders Vitocell 100-E, Vitocell 120-E, Vitocell 140-E and Vitocell 160-E.

- Freshwater modules of the type for installation on the heating water buffer cylinder include a DHW circulation pump and a diverter valve for directed return stratification (also available for wall mounting as an option).
- All pumps are highly efficient.
- With types PBMA/PBMA-S (48 l/min) and PBLA/PBLA-S (68 l/min), cascades with up to 4 identical modules are possible.
- Types PBMA-S, PBLA-S and PZMA-S are equipped with a stainless steel brazed heat exchanger.

2.2 Overview of product features

Cylinders	Type	Nominal capacity in l		Material			Version		Heat exchanger	
		From	To	Stainless steel	Enamel- led	Steel (buffer)	Horizontal	Vertical	Quantity	Sep. DHW coil
Vitocell 100-H	CHA CHAA	130	200		X		X		1	
Vitocell 300-H	EHA EHAA	160	500	X			X		1	
Vitocell 100-V	CVA CVAA CVAB CVAB-A	160	950		X			X	1	
Vitocell 100-V	CVWB CVWC	200	500		X			X	1	
Vitocell 300-V	EVIA-A EVIB-A EVIB-A+	160	500	X				X	1	
Vitocell 100-W	CUGB CUGB-A	120	150		X			X	1	
Vitocell 100-L	CVL CVLA	500	950		X			X		
Vitocell 100-B	CVB CVBB CVBC	300	950		X			X	2	
Vitocell 100-U	CVUD CVUD-A	300	300		X			X	2	
Vitocell 300-B	EVBA-A EVBB-A	300	500	X				X	2	
Vitocell 320-M	SVHA	750	910	X		X		X		X
Vitocell 340-M	SVKA	400	400	X		X		X	1	X
	SVKC	750	950	X		X		X	1	X
Vitocell 360-M	SVSB	750	950	X		X		X	1	X

2.3 Intended use of Viessmann cylinders and Vitotrans

The appliance is intended to be installed and operated only in sealed unvented systems that comply with EN 12828 / DIN 1988, or solar thermal systems that comply with EN 12977, with due attention paid to the associated installation, service and operating instructions. DHW cylinders are designed to store and heat only water of potable quality. Heating water buffer cylinders are designed to hold only water of potable quality.

The Vitotrans 353 is intended exclusively for potable water quality according to our specifications in the Viessmann brochure "TopTechnik Vitotrans 353 freshwater modules".

Intended use presupposes that a fixed installation in conjunction with permissible, system-specific components has been carried out.

Commercial or industrial usage for purposes other than heating a building or DHW shall be deemed inappropriate.

Any usage beyond this must be approved by the manufacturer in each individual case.

Incorrect usage or operation of the appliance (e.g. the appliance being opened by the system user) is prohibited and results in an exclusion of liability.

Incorrect usage also applies if components in the system are modified from their intended use (e.g. through direct DHW heating in the collector).

Adhere to statutory regulations, especially concerning the hygiene of potable water.

Selecting the cylinder type

3.1 Selection according to N_L factor

General information

The detailed specification and performance parameters for the DHW cylinder can be found in the datasheets. The following tables help with initial selection.

DHW cylinder selection

The calculated demand factor N (see page 14 onwards) is used to select the performance factor N_L of the DHW cylinder ($N_L \geq N$), which can be found in the 1st column of the following selection diagrams. DHW cylinders that have a corresponding performance factor are marked grey.

Example:

DHW heating in a two-family house in conjunction with a solar thermal system

Demand factor $N = 2.3$ ①

Selection: Vitocell 100-B, 400 l ② (from Vitocell 100 selection diagram) or Vitocell 300-B, 300 l ② (from Vitocell 300 selection diagram)

In the top line, the flow temperature of 70 °C ③ required for this output can now be read for Vitocell 100-B, 400 l with a performance factor $N_L = 2.5$ or of 90 °C ③ for Vitocell 300-B, 300 l with a performance factor $N_L = 2.4$.

The selection of the DHW cylinder should be checked using the specification in the datasheet.

Vitocell 100 selection diagram — Part 1

N_L	Vitocell 100-H 130 to 200 l			Vitocell 100-V 160 to 500 l			Vitocell 100-B 300 to 950 l Upper indirect coil			Vitocell 100-U 300 l Upper indirect coil		
	70 °C	80 °C	90 °C	70 °C	80 °C	90 °C	70 °C	80 °C	90 °C	70 °C	80 °C	90 °C
							③					
1.0	130 l						↑					
1.2		130 l										
1.4			130 l				300 l			300 l		
1.6	160 l							300 l	300 l		300 l	300 l
1.8												
2.0		160 l										
2.2			160 l	CVAA 160 l								
2.3 ①	—	—	—	—	—	—	②					
2.4	200 l				CVAA 160 l		400 l					
2.6						CVAA 160 l						
2.8												
3.0								400 l	400 l			
3.2												
3.4		200 l		CVAA 200 l								
3.6			200 l									
3.8					CVAA 200 l							
4.0						CVAA 200 l						
4.2												
4.4												
4.6												
4.8												
5.0							500 l					
5.2												
5.4												
5.6												
5.8												
6.0								500 l	500 l			
6.2												
6.4												
6.6												
6.8												

① to ③ Selection example

Selecting the cylinder type (cont.)

Vitocell 100 selection diagram — Part 2

N _L	Vitocell 100-H			Vitocell 100-V			Vitocell 100-B			Vitocell 100-U		
	130 to 200 l			160 to 500 l			300 to 950 l			300 l		
	70 °C	80 °C	90 °C	70 °C	80 °C	90 °C	Upper indirect coil			Upper indirect coil		
							70 °C	80 °C	90 °C	70 °C	80 °C	90 °C
7.0							750 l					
7.2												
7.4												
7.5												
7.6												
7.8												
8.0								750 l	750 l			
8.2												
8.4												
8.5												
8.6				CVAB								
				300 l								
8.8												
9.0												
9.2					CVAB							
					300 l							
9.4												
9.5												
9.6						CVAB						
						300 l						
9.8												
10.0							950 l					
11.0								950 l	950 l			
11.3												
12.0												
12.6												
13.0												
13.3												
14.0												
14.9												
15.0												
16.0				CVA								
				500 l								
16.5												
17.0												
18.0												
19.0					CVA							
					500 l							
20.0												
21.0						CVA						
						500 l						

3

Selecting the cylinder type (cont.)

Vitocell 100 selection diagram — Part 3

N _L	Vitocell 100-H			Vitocell 100-V 750 to 950 l			Vitocell 100-B			Vitocell 100-U		
	70 °C	80 °C	90 °C	70 °C	80 °C	90 °C	70 °C	80 °C	90 °C	70 °C	80 °C	90 °C
22.0												
23.0												
24.0												
25.0				CVAA 750 l								
26.0												
27.0												
28.0												
29.0												
30.0												
31.0												
32.0					CVAA 750 l							
33.0												
34.0												
35.0												
36.0												
37.0												
38.0						CVAA 750 l						
39.0				CVAA 950 l								
40.0												
41.0												
42.0					CVAA 950 l							
43.0												
44.0						CVAA 950 l						

Selecting the cylinder type (cont.)

Vitocell 300 selection diagram

N _L	Vitocell 300-H 160 to 500 l			Vitocell 300-V 160 to 500 l			Vitocell 300-B 300 and 500 l Upper indirect coil		
	70 °C	80 °C	90 °C	70 °C	80 °C	90 °C	70 °C	80 °C	90 °C
1.0									③ ↑
1.2									
1.4									
1.6									
1.8	160 l								
2.0							300 l		
2.2		160 l		160 l				300 l	
2.3 ①	—	—	—	—	—	—	—	—	②
2.4			160 l						300 l
2.6									
2.8									
3.0					160 l				
3.2									
3.4	200 l					160 l			
3.6									
3.8									
4.0									
4.2									
4.4									
4.6				200 l					
4.8									
5.0		200 l							
5.2									
5.4									
5.6					200 l				
5.8									
6.0							500 l		
6.2									
6.4									
6.6			200 l			200 l		500 l	
6.8									
7.0									500 l
∴									
9.5				300 l					
9.6									
9.8									
10.0	350 l				300 l	300 l			
11.0									
12.0		350 l	350 l						
13.0									
14.0									
15.0									
16.0									
17.0				500 l					
18.0									
19.0	500 l				500 l				
20.0									
21.0						500 l			
22.0		500 l							
23.0									
24.0			500 l						

① to ③ Selection example

Selecting the cylinder type (cont.)

Selection diagrams, cylinder loading system Vitocell 100-L, type CVLA, with Vitotrans 222

Performance factor N_L

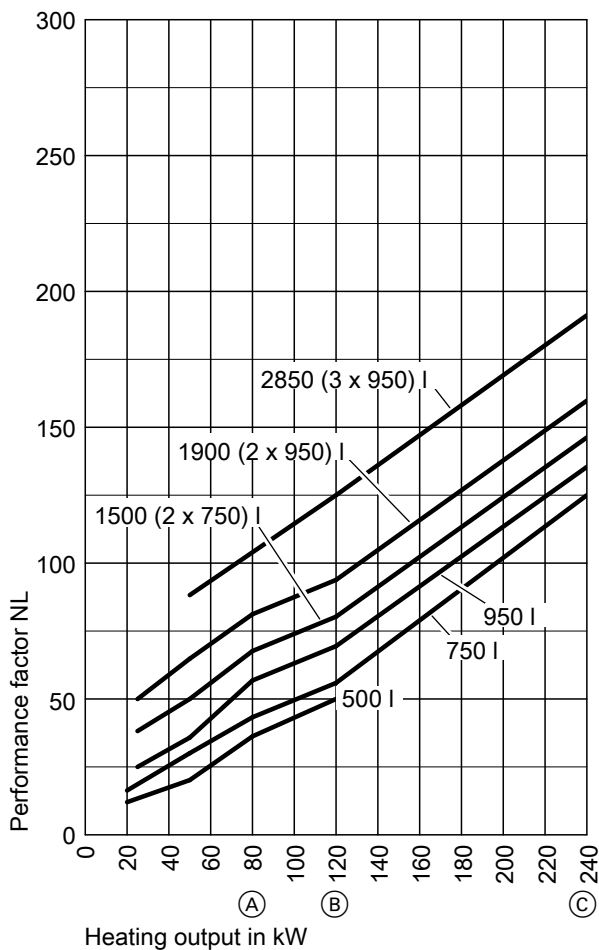

- (A) Vitotrans 222, up to 80 kW
- (B) Vitotrans 222, up to 120 kW
- (C) Vitotrans 222, up to 240 kW

Information on performance factor N_L

The performance factor N_L depends on the cylinder storage temperature T_{cyl} .

Standard values

- $T_{cyl} = 60\text{ °C} \rightarrow 1.0 \times N_L$
- $T_{cyl} = 55\text{ °C} \rightarrow 0.75 \times N_L$
- $T_{cyl} = 50\text{ °C} \rightarrow 0.55 \times N_L$
- $T_{cyl} = 45\text{ °C} \rightarrow 0.3 \times N_L$

Peak output (over 10 minutes)

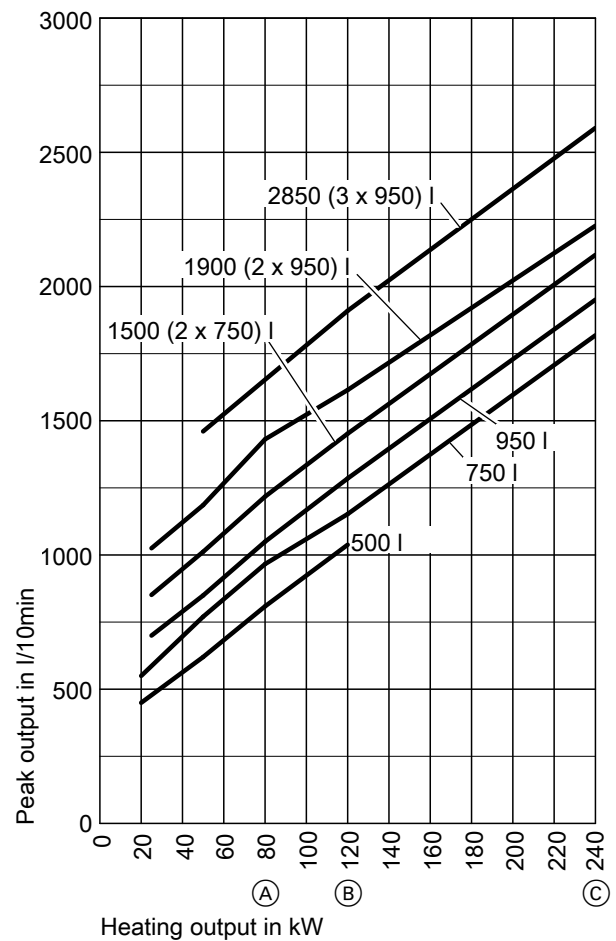

- (A) Vitotrans 222, up to 80 kW
- (B) Vitotrans 222, up to 120 kW
- (C) Vitotrans 222, up to 240 kW

Information regarding peak output

The peak output during a 10 minute period depends on the cylinder storage temperature T_{cyl} .

Standard values

- $T_{cyl} = 60\text{ °C} \rightarrow 1.0 \times \text{peak output}$
- $T_{cyl} = 55\text{ °C} \rightarrow 0.75 \times \text{peak output}$
- $T_{cyl} = 50\text{ °C} \rightarrow 0.55 \times \text{peak output}$
- $T_{cyl} = 45\text{ °C} \rightarrow 0.3 \times \text{peak output}$

Selecting the cylinder type (cont.)

3.2 Selection according to continuous output

In accordance with the required heating from 10 to 45 °C or from 10 to 60 °C and the planned flow temperature, the relevant column in the following selection table is selected. The required continuous output (see page 24 onwards) is found in the column and the cylinder type in the 1st column is read off.

Example:

DHW heating from 10 to 60 °C, flow temperature 70 °C ①
 Required continuous output: 20 kW ②, enamelled DHW cylinder, adjacent in the 1st column ③: Vitocell 100-V, 200 l or Vitocell 100-V, 300 l

The most suitable DHW cylinder is now selected based on the specification and the continuous output diagrams in the Vitocell data-sheets.

Note

The stated continuous output is only achieved if the rated boiler heating output is greater than the continuous output.
 When engineering systems with the specified or calculated continuous output, factor in a matching circulation pump.

Selection according to continuous output

Appliance	Type	Capacity	Continuous output in kW for DHW heating From 10 to 60 °C			Continuous output in kW for DHW heating From 10 to 45 °C				
			90 °C	80 °C	70 °C ①	90 °C	80 °C	70 °C	60 °C	50 °C
Horizontal DHW cylinders										
Vitocell 100-H	CHA	130 l	27	20	14	28	23	19	14	—
	CHAA	160 l	32	24	17	33	28	22	16	—
		200 l	38	29	19	42	32	26	18	—
Vitocell 300-H	EHA	160 l	28	23	15	32	28	20	14	—
	EHAA	200 l	33	25	17	41	30	23	16	—
	EHA	350 l	70	51	34	80	64	47	33	—
		500 l	82	62	39	97	76	55	38	—
DHW cylinders for wall mounted boilers										
Vitocell 100-W	CUGB	120 l	—	—	—	—	24	—	—	—
	CUGB-A	150 l	—	—	—	—	24	—	—	—
Vertical DHW cylinders										
Vitocell 100-V	CVAA	160 l	36	28	19	40	32	25	17	9
	CVAB-A	200 l	36	28	19	40	32	25	17	9
		③								
	CVAB	300 l	45	34	23	53	44	33	23	18
	CVA	500 l	53	44	33	70	58	45	32	24
	CVAA	750 l	94	75	54	109	91	73	54	33
Vitocell 300-V	EVIB-A	160 l	39	31	22	46	38	30	22	13
	EVIB-A+	200 l	39	31	22	46	38	30	22	13
	EVIB-A	300 l	52	41	29	61	51	41	30	18
	EVIA-A	500 l	59	46	33	69	58	46	34	20
Dual mode DHW cylinders (upper indirect coil)										
Vitocell 100-U	CVUD	300 l	23	20	15	31	26	20	15	11
	CVUD-A									
Vitocell 100-B	CVBC	300 l	23	20	15	31	26	20	15	11
	CVB	400 l	36	27	18	42	33	25	17	10
		500 l	36	30	22	47	40	30	22	16
	CVBB	750 l	59	49	37	76	63	49	35	26
		950 l	67	56	42	90	75	58	41	31
Vitocell 300-B	EVBB-A	300 l	36	29	20	43	35	28	20	12
	EVBA-A	500 l	49	38	27	57	48	38	28	16
Freshwater module										
Vitrans 353	PBSA		108	88	65	81	81	81	61	39
	PZSA									
	PBMA/PBMA-S		195	164	127	146	146	146	117	79
	PZMA/PZMA-S									
	PBLA/PBLA-S		277	233	181	203	203	203	166	113

① - ③ Selection example

Note

For more values, see the "Vitrans 353" datasheet.

4.1 Sizing according to peak draw-off rate and DIN 4708-2

Application

For residential buildings, the DHW demand is calculated based on the demand factor N . The calculations are set out in DIN 4708-2 and described below. Based on the demand factor N , a DHW cylinder with a corresponding performance factor N_L is then selected ($N_L \geq N$).

The performance factor N_L of a DHW cylinder can also be expressed as the peak output over 10 minutes. Systems for DHW heating are sized according to this "peak draw-off rate" if a specific volume of DHW has to be provided for a short period of time, after which a longer period of time is available to reheat the cylinder again. This may occur, e.g. in commercial enterprises or schools (intermittent operation). The 10-minute peak output is determined almost exclusively by the volume of water stored (cylinder capacity).

The performance factor N_L and the maximum continuous output of the DHW cylinders is given in the tables on page 9 onwards. For the detailed specifications, performance characteristics and continuous output diagrams, see the datasheet for the relevant DHW cylinder.

Calculation program

DHW cylinders can also be sized with the aid of the calculation program: See <https://cylinder-planner.ca.viessmann.com>.

Calculating the heat demand for DHW heating in residential buildings

This calculation is based on DIN 4708 "Central heat-water-installations" Part 2.

DIN 4708 is the basis for the standard calculation of the heat demand for central DHW heating systems in residential buildings. For the purposes of calculating the heat demand, a standard residential unit is defined as follows:

The standard residential unit is a dwelling based on statistical values, for which the demand factor $N = 1$ is as follows:

- Room factor $r = 4$ rooms
- Occupancy factor $p = 3.5$ people
- Draw-off demand $w_v = 5820$ Wh/draw-off volume for a bath

The following information is required to calculate the demand

- a) All sanitary equipment on all floors, e.g. from the building design drawing or details supplied by architect or client
- b) Number of living spaces (number of rooms) without ancillary rooms such as kitchen, hallway, bathroom and storage room, e.g. from the building design drawing or details supplied by architect or client
- c) Number of people per residential unit (occupancy factor)
If the number of occupants for each residential unit cannot be ascertained, a statistical occupancy factor p can be calculated on the basis of the room factor r for the residential unit concerned using table 1.

Table 1

Room factor r	Occupancy factor p
1.0	2.0 ^{*1}
1.5	2.0 ^{*1}
2.0	2.0 ^{*1}
2.5	2.3
3.0	2.7
3.5	3.1
4.0	3.5
4.5	3.9
5.0	4.3
5.5	4.6
6.0	5.0
6.5	5.4
7.0	5.6

Establishing the number of draw-off points to be taken into account when calculating the demand

The number of draw-off points must be taken into account when calculating the overall demand. This varies according to the specifications of the residential unit (basic or deluxe) and can be derived from tables 2 or 3.

Calculating the occupancy factor p

If the number of people per residential unit cannot be ascertained, this table can be used to calculate the occupancy factor p .

Table 2 – Residential unit with standard equipment level

Existing amenities per residential unit		Take into account when calculating the demand
Room	Equipment	
Bathroom	1 bath 140 l (according to table 4, no. 1, on page 16)	1 bath 140 l (according to table 4, no. 1, on page 16)
	or 1 shower cubicle with/without mixer tap and standard shower head	
	1 washbasin	Not taken into account
Kitchen	1 kitchen sink	Not taken into account

*1 If the residential building concerned mainly comprises residential units with 1 and 2 main rooms, increase the occupancy factor p by a factor of 0.5.

Sizing (cont.)

Table 3 – Residential unit with deluxe equipment level

Existing amenities per residential unit		Take into account when calculating the demand
Room	Equipment	
Bathroom	Bath ^{*2}	As existing, according to table 4, no. 2 to 4
	Shower cubicle ^{*2}	As existing, incl. any additional facilities according to table 4, no. 6 or 7, if arranged to permit simultaneous use ^{*3}
	Washbasin ^{*2}	Not taken into account
	Bidet	Not taken into account
Kitchen	1 kitchen sink	Not taken into account
Guest room	Bath	Per guest room: As existing, according to table 4, no. 1 to 4, with 50 % of the draw-off demand w_v
	or Shower cubicle	As existing, incl. possible additional equipment as per table 4, no. 5 to 7, with 100 % of the draw-off demand w_v
	Washbasin	At 100 % of the draw-off demand w_v according to table 4 ^{*4}
	Bidet	At 100 % of the draw-off demand w_v according to table 4 ^{*4}

Calculating the applicable draw-off demand per draw-off point to be considered

Take the respective draw-off demand w_v for the draw-off points included in the calculation of the demand factor N from table 4.

Table 4 – Draw-off demand w_v

No.	Sanitary equipment or draw-off point	DIN code	Draw-off volume per use or useful capacity in l	Draw-off demand w_v per use in Wh
1	Bath	NB1	140	5820
2	Bath	NB2	160	6510
3	Small bath and sit bath	KB	120	4890
4	Large bath (1800 mm × 750 mm)	GB	200	8720
5	Shower cubicle ^{*5} with mixer tap and economy shower head	BRS	40 ^{*6}	1630
6	Shower cubicle ^{*5} with mixer tap and standard shower head ^{*7}	BRN	90 ^{*6}	3660
7	Shower cubicle ^{*5} with mixer tap and deluxe shower head ^{*8}	BRL	180 ^{*6}	7320
8	Washbasin	WT	17	700
9	Bidet	BD	20	810
10	Hand basin	HT	9	350
11	Kitchen sink	SP	30	1160

For baths with capacities that vary considerably, apply the draw-off demand w_v in accordance with formula $w_v = c \times V \times \Delta T$ in Wh and use it in the calculation ($\Delta T = 35$ K).

Calculating the demand factor N

In order to establish the heat demand for DHW to all residential units, it is first necessary to convert the data into the heat demand for DHW of the standard residential unit.

The following characteristics of the standard residential unit are agreed:

1. Room factor $r = 4$ rooms
2. Occupancy factor $p = 3.5$ people
3. Draw-off demand $w_v = 5820$ Wh (for one bath)

The heat demand for DHW for the standard residential unit with 3.5 occupants $\times 5820$ Wh = 20370 Wh corresponds to the demand factor $N = 1$

$N =$ total of the heat demand for DHW for all residential units to be supplied with DHW, divided by the heat demand for DHW for the standard residential unit

^{*2} Size different from standard equipment level.

^{*3} If no bath is installed, a bath is assumed instead of a shower cubicle as with the standard equipment (see table 4, no. 1) unless the draw-off demand of the shower cubicle exceeds that of the bath (e.g. deluxe shower).

If several different shower cubicles are installed, at least one bath is assumed for the shower cubicle with the highest draw-off demand.

^{*4} If no bath or shower cubicle is assigned to the guest room.

^{*5} To be included in calculations only if the bath and shower cubicle are spatially separate, i.e. if simultaneous use is possible.

^{*6} Corresponding to 6 minutes in use.

^{*7} Fitting flow rate class A to EN 200.

^{*8} Fitting flow rate class C to EN 200.

Sizing (cont.)

$$N = \frac{\sum(n \cdot p \cdot v \cdot w_v)}{3.5 \cdot 5820}$$

$$= \frac{\sum(n \cdot p \cdot v \cdot w_v)}{20370}$$

- n = Number of similar residential units
 p = Occupancy factor per similar residential unit
 v = Number of similar draw-off points per similar residential unit
 w_v = Draw-off demand in Wh

(n · p · v · w_v) must be calculated for each relevant draw-off point per similar residential unit.

Now use the calculated demand factor N to select the required DHW cylinder at the appropriate heating water flow temperature from the tables on pages 9 and 12. Select a DHW cylinder with an N_L factor at least equal to N.

The demand factor N is identical to the number of standard residential units in the building project.

It does not necessarily correspond to the actual number of residential units.

Example:

For a residential building project, design the DHW system on the basis of demand factor N.

The numbers of similar residential units, the room factor and the equipment level listed in table 5 have been taken from the building plans.

The occupancy factor p was determined using the room factor r and table 1 on page 15.

The number of draw-off points to be used in the design was calculated using table 2 on page 15 and table 3 on page 16.

Table 5

No. of residential units n	Room factor r	Occupancy factor p	Amenities in the residential unit Number, description	Use when calculating the demand No. of draw-off points, description
4	1.5	2.0	1 shower cubicle with standard shower head 1 washbasin in the bathroom 1 sink in the kitchen	As per table 2 on page 15 1 shower cubicle (BRN)
10	3	2.7	1 bath 140 l 1 washbasin in the bathroom 1 sink in the kitchen	As per table 2 on page 15 1 bath (NB1)
2	4	3.5	1 shower cubicle with mixer tap and deluxe shower head 1 shower cubicle with standard shower head (in a physically separate location) 1 washbasin in the bathroom 1 sink in the kitchen	As per table 3 on page 16 1 shower cubicle (BRL)
4	4	3.5	1 bath 160 l 1 shower cubicle with deluxe shower head in a separate room 1 washbasin in the bathroom 1 bidet 1 sink in the kitchen	As per table 3 on page 16 1 bath (NB2) 1 shower cubicle (BRL)
5	5	4.3	1 bath 160 l 1 washbasin in the bathroom 1 bidet 1 bath 140 l, in the guest room 1 washbasin in the guest room 1 sink in the kitchen	As per table 3 on page 16 1 bath (NB2) 1 bath (NB1) with 50 % of the draw-off demand w _v 1 washbasin (WT) 1 bidet (BD)

Form for calculating the heat demand for DHW heating in residential buildings

Calculating the demand of residential units with centralised supply systems

Project no:
Part no:

Calculating the demand factor N for determining the required DHW cylinder size
Project

Occupancy factor p based on statistical values as per table 5, page 17

1	2	3	4	5	6	7	8	9	10	11
Sequential number of residential unit groups	Room factor r	No. of residential units n	Occupancy factor p	n · p	No. of draw-off points to consider (per residential unit)			v · w _v in Wh	n · p · v · w _v in Wh	Comments
					No. of draw-off points v	Short code	Draw-off demand w _v in Wh			
1	1.5	4	2.0	8.0	1	NB1	5820	5820	46560	NB1 for BRN
2	3.0	10	2.7	27.0	1	NB1	5820	5820	157140	
3	4.0	2	3.5	7.0	1	BRL	7320	7320	51240	
					1	BRN	3660	3660	25620	
4	4.0	4	3.5	4.0	1	NB2	6510	6510	91140	
					1	BRL	7320	7320	102480	

Sizing (cont.)

Calculating the demand of residential units with centralised supply systems					Project no: Part no:					
5	5.0	5	4.3	21.5	1	NB2	6510	6510	139965	
					(0.5)	NB1	5820	5820	62565	50 % w _v as per Tab. 3 on page 16

$$\Sigma n_i = 25$$

$$\Sigma (n \cdot p \cdot v \cdot w_v) = 676710 \text{ Wh}$$

$$N = \frac{\Sigma(n \cdot p \cdot v \cdot w_v)}{3.5 \cdot 5820} = \frac{676710}{20370} = 33.2$$

Now use the calculated demand factor $N = 33.2$ to select the required DHW cylinder from the tables in the relevant datasheets at the available heating water flow temperature (e.g. 80 °C) and a cylinder storage temperature of 60 °C. Select a DHW cylinder with an N_L factor at least equal to N .

Note

The performance factor N_L varies subject to the following variables:

- Flow temperature
- Storage temperature
- Available and transferable output

For deviating operating conditions, modify the performance factor N_L from the values shown in the tables in the relevant datasheets.

Possible DHW cylinders:

- From the Vitocell 300-H datasheet:
Vitocell 300-H with 700 l capacity ($N_L = 35$) as cylinder bank comprising 2 × Vitocell 300-H, each with 350 l capacity
- From the Vitocell 300-V datasheet:
Vitocell 300-V with 600 l capacity ($N_L = 34.8$) as cylinder bank comprising 2 × Vitocell 300-V, each with 300 l capacity

Selected DHW cylinder:

2 × Vitocell 300-V, each with 300 l capacity

Boiler supplement Z_K

According to DIN 4708-2 and VDI 3815, the rated heating output of a boiler must be increased by the boiler supplement Z_K to cover the DHW heating demand (see table 6). Observe the explanations in DIN/VDI [or local regulations].

DIN 4708 specifies 3 main demands for the rated heating output of the heat source:

Demand 1

The performance factor must be at least equal to or greater than the demand factor:

$$N_L \geq N$$

Demand 2

Only if the rated boiler heating output \dot{Q}_K or Φ_K is higher or at least equal to the continuous output, can the DHW cylinder deliver the performance factor N_L stated by the manufacturer:

$$\dot{Q}_K \geq \dot{Q}_D \text{ or } \Phi_K \geq \Phi_D$$

Demand 3

Heat generating systems used for both DHW and central heating must cover the additional output Z_K as well as the standard heat load $\Phi_{HL, \text{buil.}}$ EN 12831 (previously DIN 4701):

$$\Phi_K \geq \Phi_{HL, \text{buil.}} + Z_K$$

On the basis of DIN 4708-2, VDI 3815 is used for calculating a supplement to the rated boiler heating output as a function of the demand factor N and a minimum cylinder capacity (see table 6). It has proved successful in practice to take the boiler supplement into account according to the following relations:

$$\Phi_K \geq \Phi_{HL, \text{buil.}} \cdot \phi + Z_K$$

ϕ = Factor for utilisation of building heating (all rooms heated)

Number of residential units per building	ϕ
Up to 20	1
21 to 50	0.9
> 50	0.8

Table 6 – Boiler supplement Z_K

Demand factor N	Boiler supplement Z_K in kW
1	3.1
2	4.7
3	6.2
4	7.7
5	8.9
6	10.2
7	11.4
8	12.6
9	13.8
10	15.1
12	17.3
14	19.5
16	21.7
18	23.9
20	26.1
22	28.2
24	30.4
26	32.4
28	34.6
30	36.6
40	46.7
50	56.7
60	66.6
80	85.9
100	104.9
120	124.0
150	152.0
200	198.4
240	235.2
300	290.0

Note

In buildings with an extremely low heat load $\Phi_{HL, \text{buil.}}$, a check must be carried out to determine whether the output of the heat generator, including supplement Z_K , is sufficient for the selected performance factor. It may be necessary to select a larger DHW cylinder.

Calculating the heat demand for DHW heating in commercial enterprises

1. Demand calculation

Allow for a suitable number of washing facilities (washing/shower units) for the type of business concerned (see the earlier DIN 18228, part 3, page 4).

Per 100 users (numbers in the most numerous shift), the washing facilities listed in table 7 are required.

Table 7 – Standard working conditions^{*9}

Activity	Number of washing facilities per 100 users	Splitting the washing facilities Washing facilities/shower units
Slightly dirty	15	–/–
Moderately dirty	20	2/1
Very dirty	25	1/1

2. Sizing the DHW heating system

The following example is used to illustrate how to size the DHW heating system.

Example:

Number of employees during the most numerous shift:	150 employees
Working pattern:	2-shift operation
Type of activity:	Moderately dirty
Required DHW outlet temperature:	35 to 37 °C
Cylinder storage temperature:	60 °C
Cold water inlet temperature:	10 °C
Heating water flow temperature:	90 °C

Calculating the DHW demand

Table 7 shows that for moderately dirty work, 20 washing facilities are required per 100 employees. The ratio of washbasins to shower units is 2:1.

Therefore, 20 washbasins and 10 shower units are required for 150 employees.

Table 8 – Consumption figures for washing facilities and shower units with a DHW outlet temperature of 35 to 37 °C

Consumption point	DHW volume in l/min	Utilisation time in min	DHW consumption per use in l
Washbasins with tap	5 to 12	3 to 5	30
Washbasins with spray head	3 to 6	3 to 5	15
Circular communal washbasin for 6 people	approx. 20	3 to 5	75
Circular communal washbasin for 10 people	approx. 25	3 to 5	75
Shower unit without changing cubicle	7 to 12	5 to 6 ^{*10}	50
Shower unit with changing cubicle	7 to 12	10 to 15 ^{*11}	80

Assumptions:

The washing facilities (washbasin with spray head) are used by 120 employees (6 times in sequence) and the shower units (showers without changing cubicles) are used by 30 employees (3 times in sequence).

Using table 8, we arrive at the following DHW volume required:

a) DHW demand of the washing facilities: $120 \times 3.5 \text{ l/min} \times 3.5 \text{ min} = 1470 \text{ l}$

b) DHW demand of the showers: $30 \times 10 \text{ l/min} \times 5 \text{ min} = 1500 \text{ l}$

Together, a) and b) result in a total DHW demand of 2970 l at approx. 36 °C water temperature for a utilisation period of approx. 25 minutes.

Conversion to an outlet temperature of 45 °C results in:

$$V_{(45^\circ\text{C})} = V_{(36^\circ\text{C})} \cdot \frac{\Delta T_{(36^\circ\text{C} - 10^\circ\text{C})}}{\Delta T_{(45^\circ\text{C} - 10^\circ\text{C})}}$$

$$= 2970 \cdot \frac{26}{35} = 2206 \text{ l}$$

As 8 hours are available between the shifts for reheating the DHW cylinder, the cylinder volume should be sized for storage purposes. For this, the details for the peak output (10-minute peak output) in the tables in the relevant datasheets for the DHW cylinders are used.

From the corresponding table in the Vitocell 300-V datasheet: For Vitocell 300-V with 500 l capacity and a heating water flow temperature = 90 °C, the peak output is 10/45 °C 634 l/10 min.

Number of DHW cylinders n = calculated total volume/selected peak output (10 min output) of the individual cylinder

$$n = \frac{2206}{634} = 3.5 \text{ pce}$$

Selected DHW cylinder:

4 × Vitocell 300-V, each with 500 l capacity

Calculating the required heating output

7.5 hours are available for heating up the DHW cylinder. This gives a minimum connected load (i.e. boiler heating output) of:

$$\dot{Q}_A = \Phi_A = \frac{c \cdot V \cdot \Delta T_A}{Z_A}$$

$$= \frac{1 \cdot 2000 \cdot 50}{860 \cdot 7.5} = 15.5 \text{ kW}$$

\dot{Q}_A or Φ_A = Minimum connected load for heating the DHW cylinder in kW

V = Selected cylinder volume in l

c = Spec. thermal capacity

$$\left(\frac{1 \text{ kWh}}{860 \text{ l} \cdot \text{K}} \right)$$

ΔT_A = Temperature differential between the cylinder storage temperature and the cold water inlet temperature
(60 °C – 10 °C) = 50 K

Z_A = Heat-up time in h

As an empirical value, a heat-up time of approx. 2 hours is selected. In the above example, this means that the boiler and the circulation pump for cylinder heating (required heating water volume) should be sized for a heat-up rating of approx. 60 kW.

Calculating the heat demand for DHW heating in hotels, guest houses and residential homes

To calculate the DHW demand, it is necessary to establish the points of use in every room.

For this, only consider the largest point of use per single/double room.

^{*9} In businesses with exceptionally dirty working conditions, 25 washing facilities are required per 100 users.

^{*10} Showering time excluding changing.

^{*11} Showering time 5 to 8 min; rest of time for changing.

Sizing (cont.)

Table 9 – Draw-off demand per point of use at a DHW temperature of 45 °C

Point of use	Volume of hot water drawn off per use in l	Draw-off demand $Q_{h \max.}$	
		Per single room in kWh	Per double room in kWh
Bath	170	7.0	10.5
Shower cubicle	70	3.0	4.5
Washbasin	20	0.8	1.2

Calculating the required cylinder capacity

- $Q_{n \max.}$ = Draw-off demand per draw-off point in kWh
 n = Number of rooms with identical draw-off demand
 ϕ_n = Utilisation factor (simultaneity); can be applied conditionally:

Number of rooms	1 to 15	16 to 36	35 to 75	76 to 300
$\phi_n^{*1/2}$	1	0.9 to 0.7	0.7 to 0.6	0.6 to 0.5

- ϕ_2 = Hotel grading factor
 The following factors can be applied to reflect the category of hotel:

Hotel category	Normal	Good	High
ϕ_2	1.0	1.1	1.2

- Z_A = Heat-up time in h
 The heat-up time is subject to the rated heating output available for DHW heating. Subject to the rated boiler heating output, you can select a smaller Z_A value than 2 h.
 Z_B = Duration of the peak DHW demand in h
 Assumption: 1 to 1.5 h
 V = Volume of the DHW cylinder in l
 T_a = Cylinder storage temperature in °C
 T_e = Cold water inlet temperature in °C
 a = 0.8
 This takes into account the heat-up condition of the DHW cylinder.

Example:

Hotel with 50 rooms (30 double rooms and 20 single rooms)

- Amenities of the single rooms:
 - 5 single rooms with bath, shower cubicle and washbasin
 - 10 single rooms with shower cubicle and washbasin
 - 5 single rooms with washbasin
- Amenities of double rooms:
 - 5 double rooms with bath and washbasin
 - 20 double rooms with shower cubicle and washbasin
 - 5 double rooms with washbasin

- Heating water flow temperature = 80 °C
- Required heat-up time of the DHW cylinder 1.5 hours
- Duration of peak demand 1.5 hours

Heat demand for DHW heating

Type of room	Equipment level (draw-off point)	n	$Q_{h \max.}$ in kWh	$n \times Q_{h \max.}$ in kWh
Single room:	Bath	5	7.0	35.00
	Shower cubicle	10	3.0	30.00
	Washbasin	5	0.8	4.00
Double rooms:	Bath	5	10.5	52.50
	Shower cubicle	20	4.5	90.00
	Washbasin	5	1.2	6.00
$\Sigma (n \cdot Q_{h \max.}) = 217.50$				

$$V = \frac{860 \cdot \Sigma(n \cdot Q_{h \max.}) \cdot \phi_n \cdot \phi_2 \cdot Z_A}{(Z_A + Z_B) \cdot (T_a - T_e) \cdot a}$$

$$= \frac{860 \cdot 217.5 \cdot 0.65 \cdot 1 \cdot 1.5}{(1.5 + 1.5) \cdot (60 - 10) \cdot 0.8}$$

$$= 1520 \text{ l}$$

Selected DHW cylinders:

- 3 × Vitocell 300-H, each with 500 l capacity or
- 3 × Vitocell 300-V, each with 500 l capacity

Calculating the required heat-up output

$$\dot{Q} = \Phi = \frac{V \cdot c \cdot (T_a - T_e)}{Z_A}$$

$$= \frac{1500 \cdot (60 - 10)}{860 \cdot 1.5} = 58 \text{ kW}$$

- \dot{Q} or Φ = Heat-up output in kW
 V = Selected capacity in l
 c = Spec. thermal capacity
 $\left(\frac{1 \text{ kWh}}{860 \text{ l} \cdot \text{K}} \right)$

- T_a = Cylinder storage temperature in °C
 T_e = Cold water inlet temperature in °C
 Z_A = Heat-up time in h

The boiler and circulation pump for cylinder heating must be sized accordingly for the required heat up output. To guarantee adequate heating of the building during winter too, this heat volume must be added to the heat load.

Calculating the heat demand for DHW heating in commercial saunas

Assumptions:

- The sauna is used by 15 people/h.
- 5 showers with 12 l/min are available, i.e. the showers are utilised 3 times in a row. A showering time of 5 min results in a DHW demand of 60 l per use.
- The heat load of the building is $\dot{Q}_N = \Phi_{HL \text{ buil.}} = 25 \text{ kW}$.
- Two points must be observed to safeguard adequate DHW heating:
 - a) Adequate cylinder volume (sized according to peak output).
 - b) The boiler must be large enough to cover the DHW heating and \dot{Q}_N .

Regarding a)

- Calculating the cylinder volume:
 - 15 persons @ 60 l = 900 l at 40 °C at the DHW outlet
 - The cylinder storage temperature is 60 °C.
 - As a low temperature boiler is to be installed, the peak output at a heating water flow temperature of 70 °C must be calculated; see tables in the datasheets for the relevant DHW cylinders.
 - Conversion to an outlet temperature of 45 °C results in:

*12 For spa hotels, trade fair hotels or similar installations, select a utilisation factor of $\phi_n = 1$.

Sizing (cont.)

$$V_{(45^{\circ}\text{C})} = V_{(40^{\circ}\text{C})} \cdot \frac{\Delta T_{(40^{\circ}\text{C} - 10^{\circ}\text{C})}}{\Delta T_{(45^{\circ}\text{C} - 10^{\circ}\text{C})}}$$

$$= 900 \cdot \frac{30}{35} = 771 \text{ l}$$

Suggestion: 2 Vitocell 300-V, each with 300 l capacity with a peak output of 408 l per cylinder and 816 l as a cylinder bank (DHW temperature 45 °C).

Regarding b)

Required boiler size

As the showering process repeats hourly, the selected cylinder volume must be heated up within 1 hour. The heat volume required to achieve this is calculated as follows:

$$\dot{Q}_A = \Phi_A = \frac{V_{\text{cyl}} \cdot \Delta T_A \cdot c}{Z_A}$$

$$= \frac{600 \cdot 1 \cdot (60 - 10)}{860 \cdot 1}$$

$$= 34.9 \text{ kW}$$

\dot{Q}_A or Φ_A = Minimum connected load for heating the DHW cylinder in kW

V_{cyl} = Capacity in litres

ΔT_A = Temperature differential between the cylinder storage temperature and the cold water inlet temperature

c = Spec. thermal capacity

$$\left(\frac{1 \text{ kWh}}{860 \text{ l} \cdot \text{K}} \right)$$

Z_A = Heat-up time in h

To guarantee adequate heating of the building during winter too, this heat volume must be added to the heat load. EnEV [Germany] permits this supplement for the following reasons:

1. This is commercial utilisation.
2. There is no output restriction when using a low temperature boiler.

Calculating the heat demand for DHW heating for sports halls

Observe DIN 18032-1, "Sports grounds, sports halls" as a guideline for the sizing, design and installation of the DHW system.

DHW is drawn-off in sports halls in short bursts.

Therefore, when it comes to selecting suitable DHW cylinders, the main criterion is the "Peak draw-off rate" (10-minute peak output). The DHW heating system must be capable of ensuring the DHW delivery over the entire period of use (throughout the year).

The following values are assumed for sizing the DHW heating system:

DHW draw-off temperature:	Max. 40 °C
Water consumption per person \dot{m} :	8 l/min
Shower duration per person t :	4 min
Heat-up time Z_A :	50 min
People per heat-up time and training unit n :	Min. 25 people
Cylinder storage temperature T_a :	60 °C

Example for a simple sports hall:

1. Calculating the required DHW volume:

$$m_{\text{MW}} = t \cdot \dot{m} \cdot n$$

$$= 4 \text{ min/person} \cdot 8 \text{ l/min} \cdot 25 \text{ people}$$

$$= 800 \text{ l DHW volume at } 40^{\circ}\text{C}$$

Selected capacity: 700 l

The selected capacity should roughly correspond to the required DHW volume.

Peak output from the corresponding tables in the datasheets for the relevant DHW cylinders

Conversion to DHW outlet temperature of 40 °C at

$m_{(40^{\circ}\text{C})}$ = Peak output at a DHW outlet temperature of 40 °C

$m_{(45^{\circ}\text{C})}$ = Peak output at a DHW outlet temperature of 45 °C (according to table in DHW cylinder datasheet)

$$m_{(40^{\circ}\text{C})} = m_{(45^{\circ}\text{C})} \cdot \frac{45 - 10}{40 - 10}$$

$$= 2 \cdot 424 \text{ l/10 min}$$

$$= 848 \cdot \frac{35}{30}$$

$$= 989 \text{ l/10 min}$$

Selected DHW cylinders:

2 x Vitocell 300-H, each with 350 l, peak output at 70 °C heating water flow temperature = 989 l at 40 °C

Sizing (cont.)

2. Calculating the required heat-up output for the calculated cylinder volume:

$$\begin{aligned}\dot{Q}_A = \Phi_A &= \frac{V \cdot c \cdot (T_a - T_e)}{Z_A} \\ &= \frac{700 \cdot (60 - 10)}{860 \cdot 0.833} = 49 \text{ kW}\end{aligned}$$

\dot{Q}_A or Φ_A	=	Heat-up output in kW
V	=	Cylinder volume in l
c	=	Spec. thermal capacity $\left(\frac{1 \text{ kWh}}{860 \text{ l} \cdot \text{K}} \right)$
T_a	=	Cylinder storage temperature in °C
T_e	=	Cold water inlet temperature in °C

Size the boiler and circulation pump for cylinder heating according to the required heat-up output.

To guarantee adequate heating of the building during winter too, add this heat amount to the heat load. EnEV [Germany] permits this supplement for the following reasons:

1. This is commercial utilisation.
2. There is no output restriction when using a low temperature boiler.

4.2 Sizing according to peak flow rate with reference to DIN 1988-300

Application

For DHW heating systems operating according to the instantaneous water heating principle, e.g. freshwater modules, the DHW demand can be determined according to the peak flow rate principle. For this, the assumption is made that the peak flow rate to DIN 1988-300 determined for calculating the pipe dimensions for the DHW pipework will also have to be heated by the DHW heating system.

The peak flow rate is the sum of all connected individual consumers (total flow rate), reduced by a simultaneity factor. This is subject to the type of building.

However, to avoid oversizing, the calculated peak flow rate must not be higher than the sum of the two largest individual consumers that may be operating simultaneously. For systems with several independent consumers, e.g. in apartment buildings, also carry out this check with the total flow rate of the respective largest consumer, e.g. of all apartments.

Calculating the DHW demand

This is based on determining the peak flow rate \dot{V}_S to DIN 1988-300.

$$\dot{V}_S = a (\sum \dot{V}_R)^b - c$$

(Valid for \dot{V}_R max. = 500 l/s)

- \dot{V}_S = Peak flow rate
- \dot{V}_R = Total flow rate (sum of calculation flow rate of all consumers)
- a, b, c = Constants subject to building and its type of use (see table 11)

Table 11

Building type	Constants		
	a	b	c
Residential buildings	1.48	0.19	0.94
Hospital ward	0.75	0.44	0.18
Hotel	0.70	0.48	0.13
School	0.91	0.31	0.38
Administration building	0.91	0.31	0.38
Facility for supported living, retirement home	1.48	0.19	0.94
Care home	1.40	0.14	0.92

\dot{V}_R describes the total flow rate of all consumers. The values of the DHW calculation flow rate of individual consumers is added to this. For details of the DHW calculation flow rate, see consumer manufacturers, e.g. tap manufacturer. If no details are available, use values from DIN 1988-300:

Table 12 - Calculation flow rate for the connections on the cold and warm water sides

Mixer taps for type of draw-off point	DN	Calculation flow rate \dot{V}_R
Shower tray	15	0.15 l/s
Bath	15	0.15 l/s
Kitchen sink	15	0.07 l/s
Washbasin	15	0.07 l/s
Bidet	15	0.07 l/s

Example:

Detached house with 2 bathrooms, 1 kitchen with kitchen sink, 1 guest toilet with washbasin

Equipment, bathroom 1: Shower, washbasin

Equipment, bathroom 2: Bath, shower with body showers, 2 washbasins

Assumptions:

A manufacturer datasheet is available for the shower with body shower.

The calculated DHW flow rate is: 20 l/min = 0.33 l/s.

Standard values from Table 12 are used for the remaining consumers.

The total flow rate of the detached house is:

$$\begin{aligned} \dot{V}_R &= \text{Shower } 0.15 \text{ l/s} + \text{washbasin } 0.07 \text{ l/s} + \text{bath } 0.15 \text{ l/s} + \text{shower with body shower } 0.33 \text{ l/s} + 2 \text{ washbasins } 0.07 \text{ l/s} + \text{kitchen sink } 0.07 \text{ l/s} + \text{washbasin } 0.07 \text{ l/s} \\ &= 0.98 \text{ l/s} \end{aligned}$$

To calculate the peak flow rate, factors a, b, c for a residential building are selected from Table 11:

$$\begin{aligned} a &= 1.48 \\ b &= 0.19 \\ c &= 0.94 \end{aligned}$$

Peak flow rate:

$$\begin{aligned} \dot{V}_S &= a (\sum \dot{V}_R)^b - c \\ &= 1.48 \times 0.98^{0.19} - 0.94 \\ &= 0.53 \text{ l/s} \end{aligned}$$

The calculated peak flow rate of 0.53 l/s is greater than the sum of the two simultaneously operating consumers (shower in bathroom 1 = 0.15 l/s and shower with body shower in bathroom 2 = 0.33 l/s) = 0.48 l/s. Therefore, the value of 0.48 l/s is taken as the peak flow rate.

The DHW heating system must heat 0.48 l/s = approx. 29 l/min of DHW from 10 to 60 °C. This results in a transfer rate of approx. 101 kW. Subject to the heating water temperature or heating water storage temperature in the heating water buffer cylinder (assumption: 70 °C) select a Vitotrans 353 freshwater module from the datasheet.

Example: Vitotrans 353, type PZMA/PZMA-S for installation on a Vitocell 100-E buffer cylinder (see Table 13).

Table 13 – Excerpt from datasheet "Vitotrans 353", type PBMA/PBMA-S and PZMA/PZMA-S

Heating water temperature in the heating water buffer cylinder	Set DHW temperature	Max. draw-off rate from Vitotrans 353	Transfer output	Required heating water buffer cylinder volume per l of DHW	At 10 °C cold water inlet temperature: Max. draw-off rate at the mixing valve at				Return temperature to the heating water buffer cylinder
					40 °C	45 °C	50 °C	55 °C	
°C	°C	l/min	kW	l	l/min	l/min	l/min	l/min	°C
70	40	60	125	0.4	—	—	—	—	14
	45	60	146	0.5	70	—	—	—	15
	50	52	144	0.8	68	58	—	—	17
	55	44	137	0.9	65	56	49	—	20
	→ 60	37	127	1.1	60	52	45	40	23

Calculating the required buffer volume

To provide the energy required for DHW heating, a freshwater module is normally connected to a heating water buffer cylinder. The heating water buffer cylinder volume depends on the DHW demand of the installation, the storage temperature in the heating water buffer cylinder and the user behaviour. The following applies:

$$V_P = \dot{V} \times t \times (T_P/T_{WW}) \times s_N$$

V_P = Required minimum volume of the heating water buffer cylinder

\dot{V} = Calculated peak flow rate of the freshwater module

t = Length of time for which the peak flow rate is required. The value can be based on e.g. the time taken to fill the bath, information provided by the user, or the standard value from DIN 4708 (10 min).

(T_P/T_{WW}) = for the temperature spread between heating water buffer cylinder and DHW:

0.5 = when temperature spread is large (e.g. 90/45 °C)

0.7 = when temperature spread is medium (e.g. 70/45 °C)

1.0 = when temperature spread is small (e.g. 55/45 °C)

s_N = Safety factor for consideration of user behaviour:

1 = normal draw-off pauses

2 = short draw-off pauses

3 ... 4 = very short draw-off pauses

Example:

A buffer cylinder is to be selected for the detached house in the example on page 23 (chapter "Calculating the DHW demand").

The peak flow rate is 29 l/min.

The future system user has indicated that they "enjoy long showers". They have indicated a demand duration of 15 min.

For reasons of energy efficiency, the storage temperature in the buffer cylinder should be no more than 70 °C.

The draw-off temperature is 60 °C.

This results in a low temperature spread of 70/60 °C. Therefore the correction factor is 1.

As the future system user has indicated that they "enjoy long showers", short draw-off pauses have been assumed. Therefore, the safety factor s_N is 2.

The minimum buffer volume V_P is therefore:

$$\begin{aligned} V_P &= \dot{V} \times t \times (T_P/T_{WW}) \times s_N \\ &= 29 \text{ l/min} \times 15 \text{ min} \times 1 \times 2 \\ &= 870 \text{ l} \end{aligned}$$

According to the datasheet, a Vitocell 100-E with a volume of 950 l is selected.

4.3 Sizing according to continuous output

Application

Sizing according to continuous output is employed if hot water is to be continuously drawn from the DHW cylinder. This sizing method is therefore mainly used for commercial applications.

Determining the required DHW cylinder, example 1 (with constant flow temperatures)

Requirements:

- Continuous output in l/h or kW
- DHW outlet temperature in °C
- Cold water inlet temperature in °C
- Heating water flow temperature in °C

The DHW cylinder "Specification" is used to determine:

- Capacity and number of DHW cylinders
- Flow rate on the heating water side
- Delivery head of the circulation pump for cylinder heating

The DHW cylinders are sized in the same way.
The following example illustrates the calculation procedure.

Example:

For production purposes, a factory requires 2700 l/h DHW at 60 °C. The boilers deliver a heating water flow temperature of 90 °C. The cold water inlet temperature is 10 °C.

Continuous power	=	2700 l/h
DHW outlet temperature	=	60 °C
Cold water inlet temperature	=	10 °C
Heating water flow temperature	=	90 °C
Required cylinder type	=	Stainless steel, vertical

Calculating the number and size of the DHW cylinders

Procedure:

1. Selection of Vitocell 300-V
2. Refer to the specification for cylinder banks in the Vitocell 300-V datasheet.
3. In the table, find the line for "Continuous output from 10 to 60 °C" and Heating water flow temperature "90 °C".
4. In the column Cylinder capacity = 500 l and Number of cylinders = 3, a continuous output of 3033 l/h is specified.

Selected DHW cylinders:

3 x Vitocell 300-V, each with 500 l capacity
The continuous output of the selected DHW cylinders must be at least equal to the required continuous output.

Calculating heating water flow rate

A heating output of 162 kW is required for the calculated continuous output (see table "Specification" in the datasheet for the DHW cylinder). The required heating water flow rate is stated in the table column for the selected DHW cylinder: 9.0 m³/h, i.e. size the circulation pump for cylinder heating for a heating water flow rate of 9.0 m³/h.

Calculating the pressure drop on the heating water side

The total flow rate of 9.0 m³/h must be taken into account for the heating water flow and return lines (e.g. valves, bends) as well as the boiler when calculating the pressure drop in the complete system.

Where several cylinders are connected in parallel, the total pressure drop is equal to the pressure drop of an individual cylinder. The pressure drop of the DHW cylinder on the heating water side for the head of the circulation pump for cylinder heating is calculated as follows: As the 3 cylinders are connected in parallel, each cylinder has a heating water flow rate of 3.0 m³/h (see following diagram). Refer to the diagram "Pressure drop on the heating water side" in the datasheet for "Vitocell 300-V". For a heating water flow rate of 3000 l/h, read the pressure drop off the straight line of the cylinder with a capacity of 500 l: 90 mbar (9 kPa)

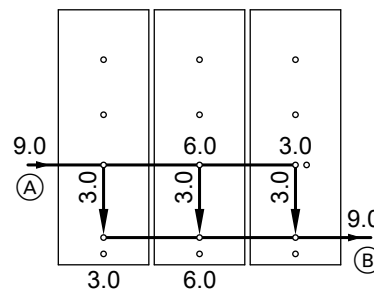

- (A) Heating water flow
- (B) Heating water return

Result:

Total heating water flow rate = 9.0 m³/h
Heating water flow rate per cylinder = 3.0 m³/h
Pressure drop on the heating water side of the DHW cylinder = 90 mbar (9 kPa)

Sizing the circulation pump for cylinder heating

The circulation pump for cylinder heating must therefore deliver a heating water flow rate of 9.0 m³/h and overcome the pressure drop on the heating water side of 90 mbar (9 kPa) for the 3 cylinders, plus the pressure drop of the boiler, the pipework between the cylinders and the boiler, and the individual pressure drop values of fittings and valves.

The following rule of thumb applies: If the available boiler heating output \dot{Q}_K (to DIN 4701) or Φ_K (to EN 12831) is lower than the continuous output \dot{Q}_{cyl} or Φ_{cyl} , it is sufficient to size the circulation pump for cylinder heating to suit the transfer of the boiler heating output. If, on the other hand, the boiler heating output is greater than the continuous output \dot{Q}_{cyl} or Φ_{cyl} , the circulation pump for cylinder heating can be sized to suit the continuous output as a maximum rating.

Determining the required DHW cylinder, example 2 (with a fixed heat generator temperature differential)

Requirements:

- Required continuous output in kW or in l/h (conversion required)
- DHW outlet temperature in °C
- Cold water inlet temperature in °C

- Heating water flow temperature in °C
- Heating water return temperature in °C

Sizing (cont.)

Conversion of continuous output from l/h to kW

$$\begin{aligned} \dot{Q}_{\text{req.}} \text{ or } \Phi_{\text{req.}} &= \text{Continuous output in kW} \\ \dot{m}_{\text{WW}} &= \text{Continuous output in l/h} \\ c &= \text{Spec. thermal capacity} \\ &= \left(\frac{1 \text{ kWh}}{860 \text{ l} \cdot \text{K}} \right) \\ \Delta T_{\text{WW}} &= \text{Temperature differential between DHW outlet} \\ &\text{temperature and cold water inlet temperature in} \\ &\text{K} \\ \dot{Q}_{\text{req.}} \text{ or } \Phi_{\text{req.}} &= \dot{m}_{\text{DHW}} \cdot c \cdot \Delta T_{\text{DHW}} \end{aligned}$$

The number of DHW cylinders required and their required size can be determined using the diagrams for the continuous output of the DHW cylinders concerned.

Example:

$$\begin{aligned} \text{Required continuous output} &= 1700 \text{ l/h} \\ \text{Heating water flow temperature} &= 80 \text{ }^\circ\text{C} \\ \text{Heating water return temperature} &= 60 \text{ }^\circ\text{C} \\ \text{Heating water temperature differential} &= 80 \text{ }^\circ\text{C} - 60 \text{ }^\circ\text{C} = 20 \text{ K} \\ \text{Cold water inlet temperature} &= 10 \text{ }^\circ\text{C} \\ \text{DHW outlet temperature} &= 45 \text{ }^\circ\text{C} \end{aligned}$$

A vertical DHW cylinder has to be used on account of the structural characteristics of the building.

Conversion of continuous output from l/h to kW

$$\begin{aligned} \dot{Q}_{\text{req.}} \text{ or } \Phi_{\text{req.}} &= \dot{m}_{\text{WW}} \cdot c \cdot \Delta T_{\text{WW}} \\ &= 1700 \cdot \frac{1}{860} \cdot (45 - 10) \\ &= 69 \text{ kW} \end{aligned}$$

Calculating the continuous output of the various cylinder sizes

As the method of calculation is the same for all cylinder sizes, the process for calculating the continuous output of the Vitocell 300-V DHW cylinder with 300 l capacity is shown as an example. From point ① (20 K) via point ② (required DHW heating from 10 °C to 45 °C at heating water flow temperature 80 °C) read at point ③: Continuous output of the DHW cylinder 37.5 kW

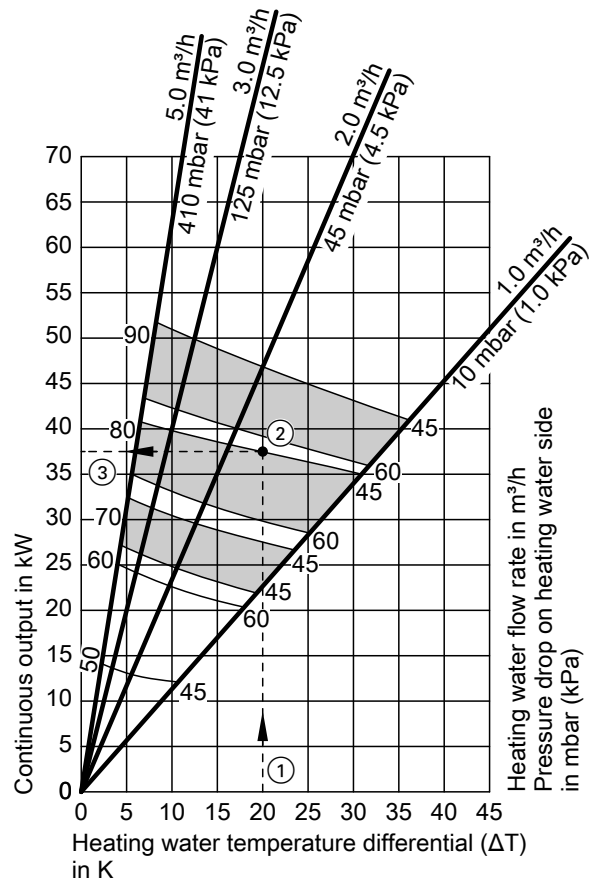

Calculating the required number of DHW cylinders of a given size

$$\begin{aligned} n &= \text{Required number of DHW cylinders} \\ \dot{Q}_{\text{req.}} \text{ or } \Phi_{\text{req.}} &= \text{Required continuous output in kW} \\ \dot{Q}_{\text{cyl.}} \text{ or } \Phi_{\text{cyl.}} &= \text{Continuous output of the selected DHW cylinders} \\ &\text{in kW} \end{aligned}$$

$$\begin{aligned} n &= \frac{\dot{Q}_{\text{req.}}}{\dot{Q}_{\text{cyl.}}} = \frac{\Phi_{\text{req.}}}{\Phi_{\text{cyl.}}} \\ &= \frac{69 \text{ kW}}{37.5 \text{ kW}} = 1.84 \end{aligned}$$

Required number of DHW cylinders = 2

Sizing (cont.)

Calculating the required flow rate on the heating water side

- \dot{m}_{HW} = Flow rate on the heating water side in l/h
 $\dot{Q}_{req.}$ or $\Phi_{req.}$ = Required continuous output in kW
 ΔT_{HW} = Heating water temperature differential in K
 c = Spec. thermal capacity

$$\left(\frac{1 \text{ kWh}}{860 \text{ l} \cdot \text{K}} \right)$$

$$\dot{m}_{HW} = \frac{\dot{Q}_{req.}}{c \cdot \Delta T_{HW}} = \frac{860 \cdot \dot{Q}_{req.}}{\Delta T_{HW}}$$

$$= \frac{\Phi_{req.}}{c \cdot \Delta T_{HW}} = \frac{860 \cdot \Phi_{req.}}{\Delta T_{HW}}$$

$$= \frac{860 \cdot 69}{20}$$

$$= 2967 \text{ l/h (total)}$$

$$= 1484 \text{ l/h (per DHW cylinder)}$$

5.1 Applications and advantages

The Viessmann cylinder loading system is a combination of a Vitocell 100-L DHW cylinder and a modular Vitotrans 222 heat exchanger set.

The cylinder loading system for DHW heating is a preferred choice for the following applications and conditions:

- Heating circuits requiring low return temperatures or where the return temperatures are limited, e.g. for district heating or condensing boilers:
Heating from the heating temperature (10 °C) to the end temperature (60 °C) is achieved in one circulation via the heat exchanger of the Vitotrans 222. This wide temperature spread on the DHW side results in a low return temperature on the heating water side. A low return temperature enables a high condensation rate when utilising condensing technology.
- Large cylinder volumes with offset heating and draw-off times, e.g. where water is drawn off at peak times in schools, sports centres, hospitals, army barracks, council facilities, apartment buildings

- Short-term peak loads, i.e. high draw-off rates and varying reheat times, e.g. DHW heating in swimming pools, sports facilities, industrial enterprises and abattoirs
- Where space is limited, as the cylinder loading system can transfer a high output.

5.2 Function description of the cylinder loading system

Operation with modulating flow temperature

During the heating process (no draw-off), loading pump (R) within the cylinder loading system withdraws cold water (T) from the bottom of DHW cylinder (U); this is then heated in heat exchanger set (C) and resupplied to the top (B) of the DHW cylinder.

To avoid disturbing the thermal stratification layers inside the DHW cylinder, cylinder loading pump (R) will only be switched on if temperature sensor (L) signals that the set temperature has been reached.

The required heat exchanger transfer output is set by line regulating valve (O).

Mixer assembly (accessories) (N) mixes the heating water on the primary side in accordance with the set DHW temperature. A set DHW temperature of max. 60 °C prevents scaling of the plate heat exchanger.

Pasteurisation is feasible in conjunction with Viessmann boilers with the Vitotronic boiler control units or with the Vitotronic 200-H heating circuit control units (accessories).

The base load is covered by the continuous output of the Vitotrans 222.

Any additional hot water demand during peak times is covered by the cylinder volume.

During draw-off and once draw-off has ended, the cylinder volume is reheated to the set temperature via the Vitotrans 222. In the fully heated state (no draw-off), cylinder loading pump (R) and heating circuit pump (E) in the Vitotrans 222 are switched OFF.

Provided the above set heating water and DHW temperatures are observed, the Vitotrans 222 heat exchanger set can be operated up to a total water hardness of 20 °dH (total of alkaline earths 3.6 mol/m³).

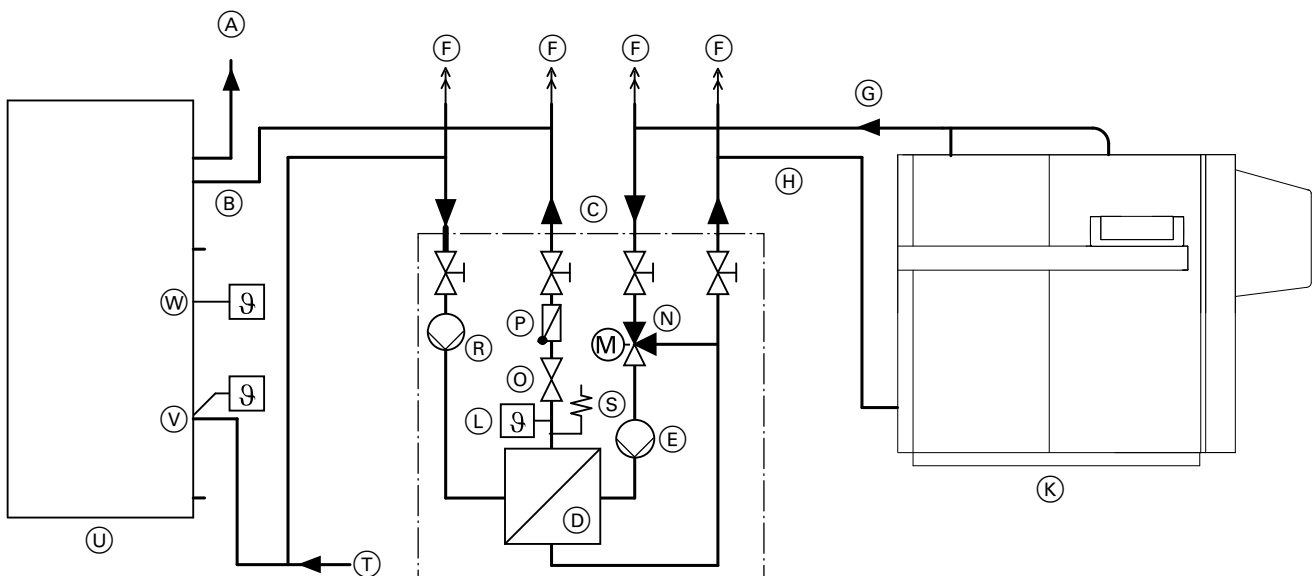

- | | |
|--|--|
| <ul style="list-style-type: none"> (A) DHW (B) DHW inlet from heat exchanger (C) Vitotrans 222 heat exchanger set (D) Plate heat exchanger (E) Heating circuit pump (primary), highly efficient (F) Air vent valve (G) Heating water flow (H) Heating water return (K) Boiler (L) Temperature sensor | <ul style="list-style-type: none"> (N) Mixer assembly (O) Line regulating valve (P) Non-return valve (R) Cylinder loading pump (secondary), highly efficient (S) Safety valve, does not replace the DHW cylinder safety valve to DIN 1988 (T) Shared cold water connection with safety assembly to DIN 1988 (U) Vitocell 100-L, (here: 500 l capacity) (V) Lower cylinder temperature sensor (OFF) (W) Upper cylinder temperature sensor (ON) |
|--|--|

Operation with constant flow temperature

The Vitotrans 222 heat exchanger set is operated without a mixer assembly. Limit the heating water temperature to 75 °C.

The required DHW temperature and transfer output are set by adjusting the circulating volume for the heating process according to the heating output of the heat exchanger at line regulating valve (L).

If the available boiler output is below that of the Vitotrans 222, the setting is done according to the boiler output.

High or medium draw-off rates are covered by the DHW cylinder.

Cold water flows into the DHW cylinder to replace the hot water drawn. If the cold water layer inside the DHW cylinder reaches upper temperature controller (T), the Vitotrans 222 starts.

The base load is covered by the continuous output of the Vitotrans 222. Any additional hot water demand during peak times is covered by the cylinder volume.

Cylinder loading systems — Vitocell 100-L with Vitotrans 222 (cont.)

During draw-off and once draw-off has ended, the cylinder volume is reheated to the set temperature via the Vitotrans 222. In the fully heated state (no draw-off), cylinder loading pump (N) and heating circuit pump (E) in the Vitotrans 222 are switched OFF. Provided the above set heating water and DHW temperatures are observed, the Vitotrans 222 heat exchanger set can be operated up to a total water hardness of 20 °dH (total of alkaline earths 3.6 mol/m³).

Note

The maintenance interval depends on the water hardness, the set DHW temperature and the volume of hot water drawn.

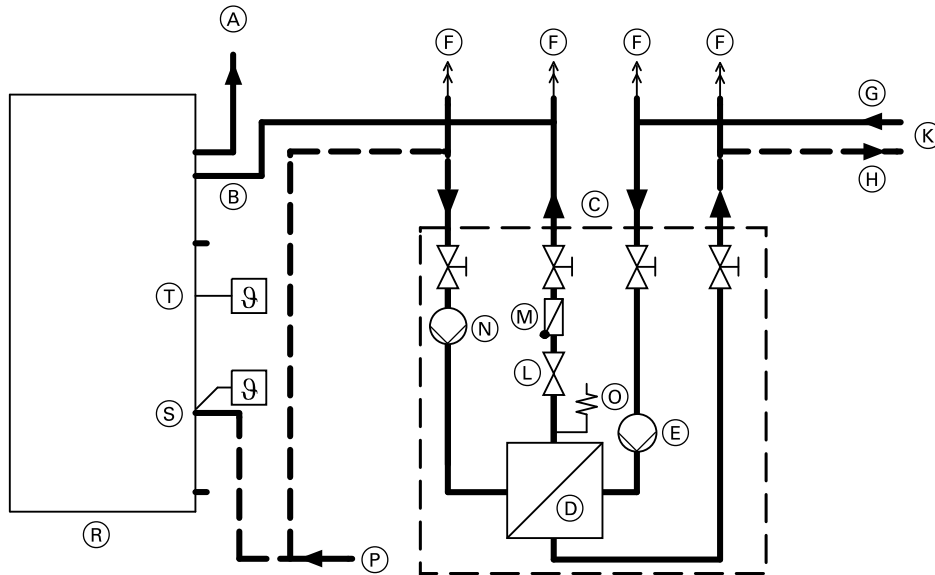

- (A) DHW
- (B) DHW inlet from heat exchanger
- (C) Vitotrans 222 heat exchanger set
- (D) Plate heat exchanger
- (E) Heating circuit pump (primary), highly efficient
- (F) Air vent valve
- (G) Heating water flow
- (H) Heating water return
- (K) Heat source with a constant flow temperature (e.g. district heating, max. 75 °C)
- (L) Line regulating valve
- (M) Non-return valve
- (N) Cylinder loading pump (secondary), highly efficient
- (O) Safety valve
- (P) Shared cold water connection with safety assembly to DIN 1988
- (R) Vitocell 100-L, (here: 500 l capacity)
- (S) Lower temperature controller (OFF)
- (T) Upper temperature controller (ON)

Operation with a heat pump in conjunction with a heating lance for DHW heating

In the cylinder loading system, loading pump (M) withdraws the cold water from the bottom of DHW cylinder (O) during the cylinder heating process (no draw-off). The water is heated in plate heat exchanger (D) and resupplied to the DHW cylinder via heating lance (C) mounted in flange (B). The generously sized outlet apertures in the heating lance result in low flow velocities, which in turn provide a clean temperature stratification inside the DHW cylinder.

Installation of the optional immersion heater EHE (accessories) into the DHW cylinder flange enables DHW heating to be boosted further.

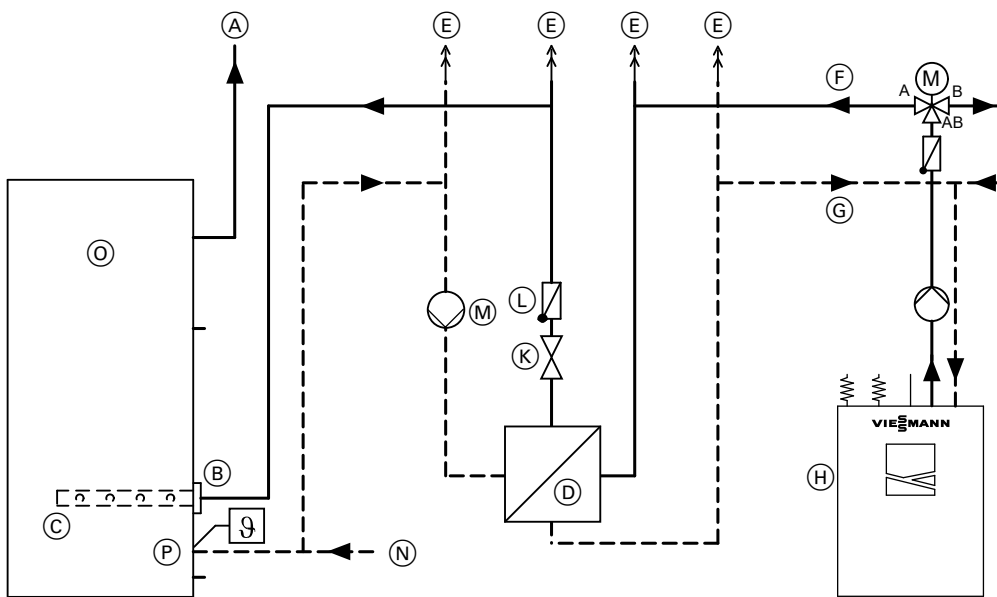

- | | |
|---|--|
| <ul style="list-style-type: none"> (A) DHW (B) DHW inlet from heat exchanger (C) Heating lance (D) Plate heat exchanger (E) Air vent valve (F) Heating water flow from the heat pump (G) Heating water return to the heat pump | <ul style="list-style-type: none"> (H) Heat pump (K) Line regulating valve (L) Non-return valve (M) Cylinder loading pump (N) Shared cold water connection with safety assembly to DIN 1988 (O) Vitocell 100-L (P) Cylinder temperature sensor of the heat pump |
|---|--|

5.3 General formulas for calculating the cylinder loading system

Calculation based on water volume

With reference to EN 12831, $Q = \Phi$ is used for heat volume and $\dot{Q} = L$ for the heating output (continuous output) instead of the values previously used in DIN 4701.

$$V_D = \frac{L \cdot t}{c \cdot \Delta T} \text{ in l}$$

$$V_{\text{ttl.}} = V_D + V_{\text{cyl.}} \text{ in l}$$

$$= n_Z \cdot \dot{V} \cdot t \text{ in l}$$

Calculation based on heat volume

With reference to EN 12831, $Q = \Phi$ is used for heat volume and $\dot{Q} = L$ for the heating output (continuous output) instead of the values previously used in DIN 4701.

$$\Phi_D = L \cdot t \text{ in kWh}$$

$$\Phi_{\text{ttl.}} = V_{\text{ttl.}} \cdot \Delta T \cdot c \text{ in kWh}$$

$$= \Phi_{\text{cyl.}} + \Phi_D \text{ in kWh}$$

$$= V_{\text{ttl.}} \cdot \Delta T \cdot c = \Phi_{\text{cyl.}} + \Phi_D$$

$$\Phi_{\text{cyl.}} = V_{\text{cyl.}} \cdot c \cdot (T_a - T_e) \text{ in kWh}$$

5.4 Sample calculation

A sports centre is equipped with 16 showers which are limited to **15 l/min**.

According to design requirements, **8 showers** are operated simultaneously for up to **30 min** continuously. The drawing temperature should be **40 °C**. A max. of **100 kW boiler output** is available for DHW heating.

$$c = \text{Spec. thermal capacity} \\ \left(\frac{1 \text{ kWh}}{860 \text{ l} \cdot \text{K}} \right)$$

n = Number of DHW cylinders

n_z = Number of draw-off points

Φ_D = Heat volume in kWh available by continuous output

L = Continuous output in kW

Φ_{ttl} = Total heat demand in kWh (for production and demand)

Φ_{cyl} = Usable heat volume of the total cylinder volume in kWh

$\Phi_{\text{cyl. ind.}}$ = Usable heat volume of a single DHW cylinder in kWh

t = Time in h

T_a = Cylinder storage temperature in °C

T_e = Cold water inlet temperature in °C

ΔT = Temperature differential between draw-off temperature and cold water inlet temperature in K

\dot{V} = Draw-off rate per draw-off point in l/h

V_D = DHW heated by continuous output in l

V_{ttl} = Total draw-off volume in l

V_{cyl} = Usable cylinder capacity in l

Calculation of the cylinder size based on water volume

Over a period of 30 min, a total water volume V_{ttl} at a temperature of 40 °C is required.

$$V_{\text{ttl}} = n_z \cdot \dot{V} \cdot t \\ = 8 \text{ showers} \cdot 15 \text{ l/min} \cdot 30 \text{ min} \\ = 3600 \text{ l}$$

Of the 3600 l, the 100 kW connected load can deliver a water volume V_D over a period of 30 min.

$$V_D = \frac{L \cdot t}{c \cdot \Delta T}$$

$$V_D = \frac{100 \text{ kW} \cdot 0.5 \text{ h} \cdot 860 \text{ l} \cdot \text{K}}{1 \text{ kWh} \cdot (40 - 10) \text{ K}} \\ = 1433 \text{ l}$$

This means that the DHW cylinder must make the following water volume available at a temperature of 40 °C:

$$3600 \text{ l} - 1433 \text{ l} = 2167 \text{ l}$$

At a storage temperature of 60 °C, the required cylinder volume V_{cyl} results.

$$V_{\text{cyl}} = \frac{2167 \text{ l} \cdot (40 - 10) \text{ K}}{(60 - 10) \text{ K}} = 1300 \text{ l}$$

The calculated number n of Vitocell 100-L with a volume of 750 l each results from the following:

$$n = \frac{1300 \text{ l}}{750 \text{ l}} = 1.73$$

Selected cylinder loading system:

2 Vitocell 100-L, each with 750 l capacity, and 1 Vitotrans 222 heat exchanger set with a heating output of 120 kW (in accordance with max. available boiler output according to the sample calculation, i.e. 100 kW).

Calculation of the cylinder size based on heat volume

Over a period of 30 min (as per calculation), a total water volume of 3600 l at a temperature of 40 °C is required. This corresponds to a heat volume of Φ_{ttl} .

$$\Phi_{\text{ttl}} = V_{\text{ttl}} \cdot \Delta T \cdot c \\ = 3600 \text{ l} \cdot 30 \text{ K} \cdot \frac{1 \text{ kWh}}{860 \text{ l} \cdot \text{K}} = 126 \text{ kWh}$$

The connected load can, over the drawing period of 30 min, provide a heat volume of Φ_D .

$$\Phi_D = L \cdot t \\ = 100 \text{ kW} \cdot 0.5 \text{ h} = 50 \text{ kWh}$$

This means that the DHW cylinder must store a heat volume of Φ_{cyl} .

$$\Phi_{\text{cyl}} = \Phi_{\text{ttl}} - \Phi_D \\ = 126 \text{ kWh} - 50 \text{ kWh} = 76 \text{ kWh}$$

Each individual Vitocell 100-L DHW cylinder with 750 l cylinder capacity stores the following heat volume $\Phi_{\text{cyl. ind.}}$:

$$\Phi_{\text{cyl. ind.}} = 750 \text{ l} \cdot (60 - 10) \text{ K} \cdot \frac{1 \text{ kWh}}{860 \text{ l} \cdot \text{K}} \\ = 43.6 \text{ kWh}$$

This results in the calculated number of cylinders n .

$$n = \frac{\Phi_{\text{cyl.}}}{\Phi_{\text{cyl. ind.}}} \\ = \frac{76 \text{ kWh}}{43.6 \text{ kWh}} = 1.74$$

Selected cylinder loading system:

2 Vitocell 100-L, each with 750 l cylinder capacity, and 1 Vitotrans 222 heat exchanger set with a heating output of 120 kW (in accordance with max. available boiler output according to the sample calculation, i.e. 100 kW)

6.1 Connection on the DHW side

General information

For connection on the DHW water side: See www.viessmann-schemes.com.

Fittings that are installed in the connection line must conform to DIN 1988 (see diagrams on page 35) and DIN 4753 [or local regulations].

These fittings comprise the following:

- Shut-off valves
- Drain valve
- Pressure reducer
- Safety valve
- Non-return valve
- Pressure gauge
- Flow regulating valve
- Drinking water filter

Pressure reducer (to DIN 1988)

Install this device if the pressure in the pipework at the connection point exceeds 80 % of the safety valve response pressure.

It is advisable to install the pressure reducer immediately downstream of the water meter. This creates nearly the same pressures in the entire DHW system, which is thereby protected against overpressure and water hammer.

According to DIN 4109, the static pressure of the water supply system after distribution over the various floors upstream of the fittings should not be higher than 5 bar (0.5 MPa).

The system must be equipped with a type-tested diaphragm safety valve as protection against overpressure.

Permissible operating pressure: 10 bar (1 MPa).

The connection diameter of the safety valve must be as follows:

- Up to 200 l capacity
 - min. R ½ (DN 15),
 - max. heat input 75 kW
- Between 200 and 1000 l capacity
 - min. R ¾ (DN 20),
 - max. heat input 150 kW
- Between 1000 and 5000 l capacity
 - min. R 1 (DN 25),
 - max. heat input 250 kW

Select a safety valve with a higher rating if the heat input of the DHW cylinder is greater than the maximum heat input assigned to the capacity. (See DIN 4753-1, issue 3/88, section 6.3.1).

Install the safety valve in the cold water line. It must not be able to be isolated from the DHW cylinder or the cylinder bank. There must be no constrictions in the pipework between the safety valve and the DHW cylinder.

Never seal off the safety valve discharge pipe. The overpressure can damage the system. Ensure that any expelled water is safely and visibly drained into a drainage system. Position a sign close to the safety valve discharge pipe, or ideally on the safety valve itself, with the following inscription:

"For safety reasons, water may be discharged from the discharge pipe during heating! Do not seal off!"

Recommendation: Install the safety valve above the top edge of the DHW cylinder. Then the DHW cylinder will not need to be drained when working on the safety valve.

Non-return valve

This prevents system water and heated water from flowing back into the cold water pipe and into the mains water supply.

Pressure gauge

Provide a connection for a pressure gauge.

Flow regulating valve

We recommend that a flow regulating valve is installed and the maximum water flow rate is adjusted in accordance with the 10-minute peak output of the DHW cylinder.

Drinking water filter

Install a drinking water filter in accordance with DIN 1988. The installation of a drinking water filter prevents dirt from being introduced into the drinking water system.

Only for cylinder banks Vitocell 300-H:

With DHW outlet temperatures in excess of 60 °C, the connection line on the DHW side can also be connected in series, in multi cylinder banks.

Installation — DHW cylinders (cont.)

Vitocell 100-H and Vitocell 300-H

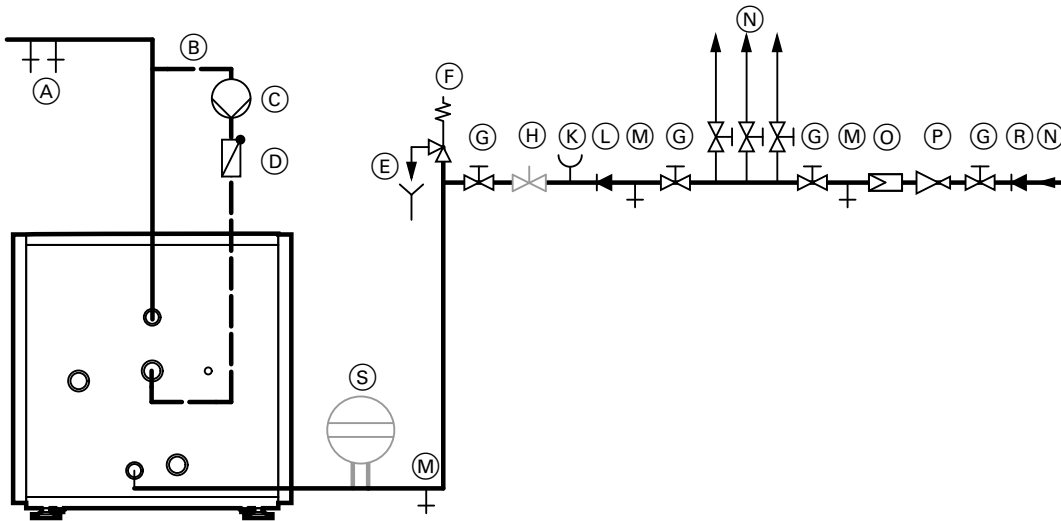

Connection on the DHW side to DIN 1988

- | | |
|---|--|
| (A) DHW | (K) Pressure gauge connector |
| (B) DHW circulation pipe | (L) Non-return valve |
| (C) DHW circulation pump | (M) Drain |
| (D) Spring-loaded check valve | (N) Cold water |
| (E) Visible discharge pipe outlet point | (O) Drinking water filter |
| (F) Safety valve | (P) Pressure reducer DIN 1988-200:2012-05 |
| (G) Shut-off valve | (R) Non-return valve/pipe separator |
| (H) Flow regulating valve | (S) Diaphragm expansion vessel, suitable for potable water |

Vitocell 100-V and Vitocell 300-V

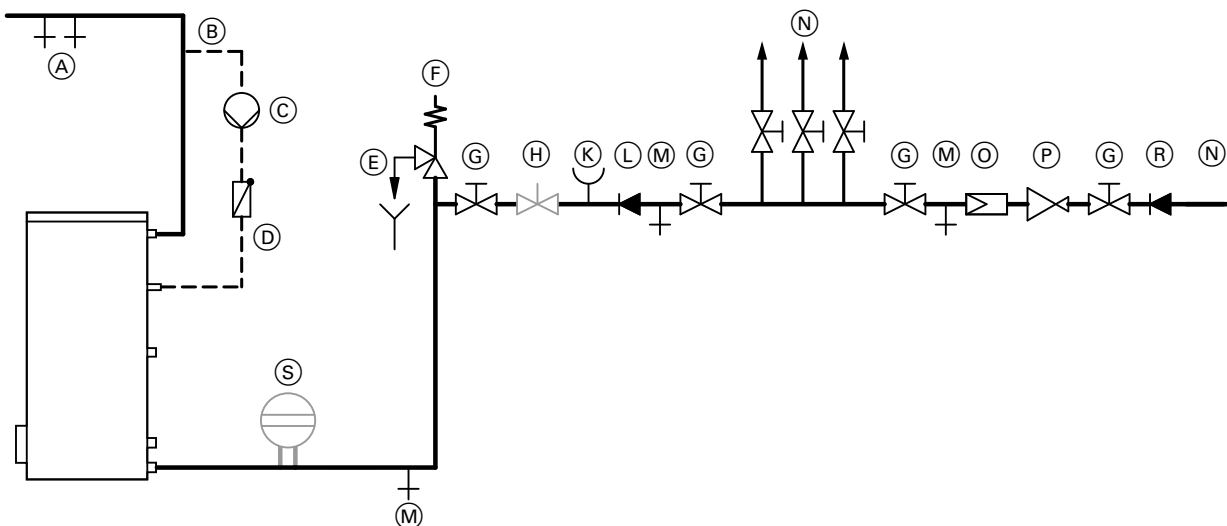

Connection on the DHW according to with DIN 1988

- | | |
|---|---|
| (A) DHW | (H) Flow regulating valve |
| (B) DHW circulation pipe | (K) Pressure gauge connector |
| (C) DHW circulation pump | (L) Non-return valve |
| (D) Spring-loaded check valve | (M) Drain |
| (E) Visible discharge pipe outlet point | (N) Cold water |
| (F) Safety valve | (O) Drinking water filter |
| (G) Shut-off valve | (P) Pressure reducer DIN 1988-200:2012-05 |

5414646

Installation — DHW cylinders (cont.)

- Ⓡ Non-return valve/pipe separator
- Ⓢ Diaphragm expansion vessel, suitable for potable water

Cylinder banks with Vitocell 300-H

Note

- Observe stacking height:
Vitocell 300-H, 350 l: Max. 2 pce
Vitocell 300-H, 500 l: Max. 3 pce
- Observe the cross-sections of DHW connecting pipes.

700 and 1000 l (2 cylinders)

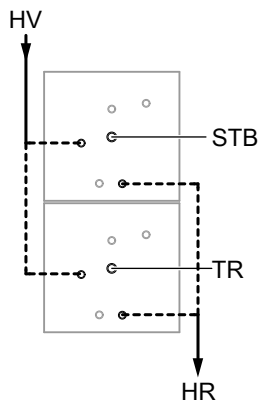

1500 l (3 cylinders)

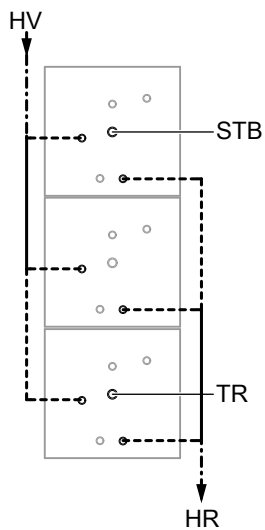

- DN 32
- DN 50
- - - - - DN 80
- DN 100
- - - - - DN 125

2 x 700 l and 2 x 1000 l (2 x 2 cylinders)

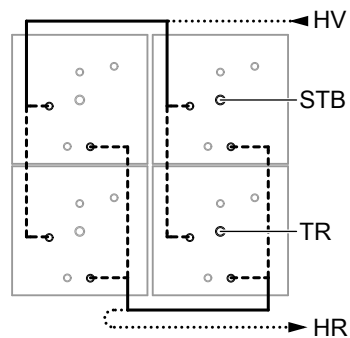

2 x 1500 l (2 x 3 cylinders)

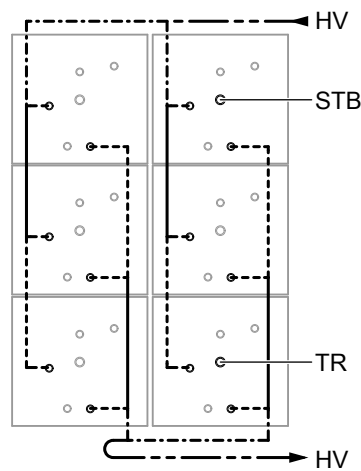

- HR Heating water return
- HV Heating water flow
- STB High limit safety cut-out (if required)
- TR Temperature controller

Installation — DHW cylinders (cont.)

Vitotrans 222 (accessories) in conjunction with a Vitocell 100-L

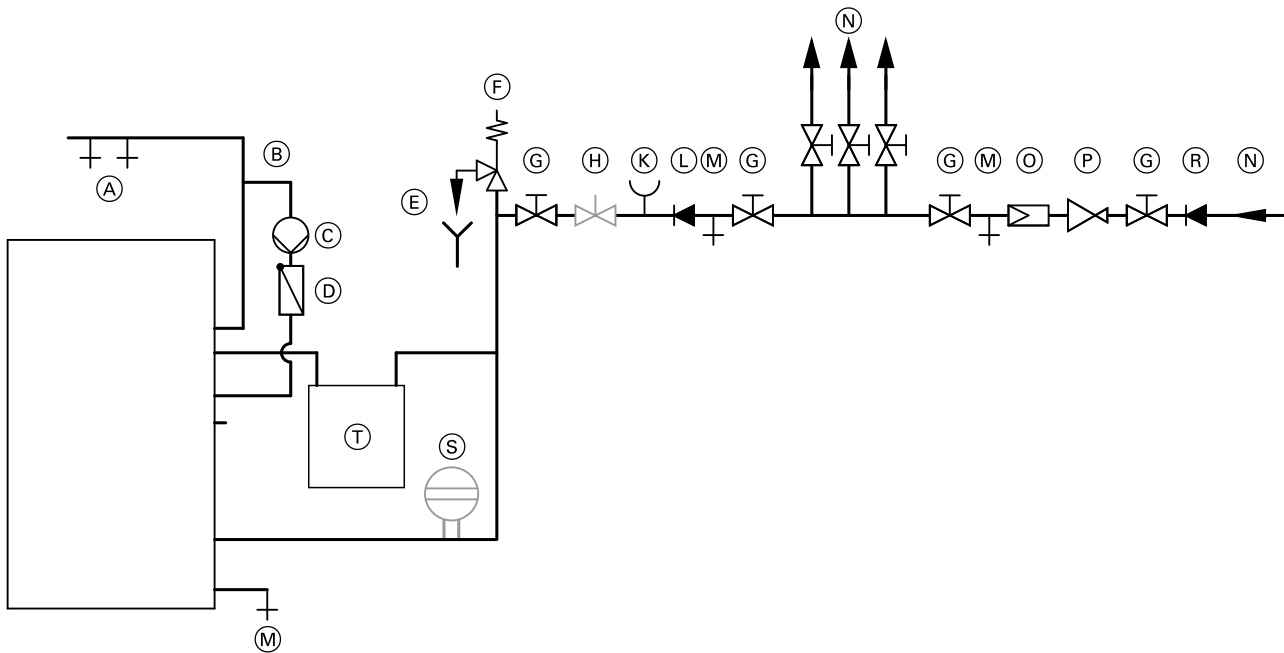

Connection to DIN 1988

- | | |
|---|--|
| (A) Draw-off points (DHW) | (K) Pressure gauge connector |
| (B) DHW circulation pipe | (L) Non-return valve |
| (C) DHW circulation pump | (M) Drain |
| (D) Spring-loaded check valve | (N) Cold water |
| (E) Visible discharge pipe outlet point | (O) Drinking water filter |
| (F) Safety valve | (P) Pressure reducer DIN 1988-200:2012-05 |
| (G) Shut-off valve | (R) Non-return valve/pipe separator |
| (H) Flow regulating valve | (S) Diaphragm expansion vessel, suitable for potable water |
| | (T) Vitotrans 222 |

Installation information

- The pipework downstream of the Vitotrans 222 must **not be made from zinc-plated steel pipes**.
- Establish the cold water connection with a tee with straight flow to the cold water connection of the Vitocell 100-L. Always make the cold water connection to the Vitotrans 222 as a tee branch.
- The safety valve underneath the Vitotrans 222 does not replace the safety valve of the safety assembly to DIN 1988.

6.2 DHW circulation pipes

For reasons of hygiene and convenience, DHW circulation pipes are installed in DHW heating systems. Observe the applicable standards and rules. Always fit DHW circulation pipes or DHW circulation systems with appropriate pumps, hydraulically adjust and thermally insulate them in accordance with the applicable regulations. Take the applicable standards and regulations into account (e.g. DVGW Codes of Practice W551/W553 and DIN 1988/TRWI).

The flow rate of the circulation system is determined according to the scale of the pipework, the thermal insulation and the targeted or required maximum temperature differential between the cylinder outlet (DHW) and the DHW circulation inlet (DHW circulation).

Depending on the type of DHW heating system, there are various connection options for the DHW circulation pipe. Virtually all DHW cylinders are fitted with connections for the DHW circulation pipe in the upper third of the cylinder. The exception to this are DHW heating systems in continuous operation, such as freshwater modules or combi cylinders with an integral DHW indirect coil (Vitocell 320-M/Vitocell 340-M/Vitocell 360-M). They have a "threaded DHW circulation fitting", which means that the DHW circulation line is routed partially into the heat exchanger. If this is not the case, the DHW circulation pipe can also be connected to the cold water inlet of the DHW cylinder.

Connecting to the cold water inlet is also an option for DHW cylinders where, due to the ratio of the draw-off rate and/or the flow rate of DHW circulation to the cylinder volume, continuous mixing of the DHW cylinder content must be expected, e.g. in case of very small DHW cylinders. Connecting to the cold water inlet may also be advisable in the case of extremely high DHW circulation flow rates. In poorly insulated pipework or very widely branched systems in particular, extremely high flow rates may be necessary. It is then important to ensure that high flow velocities cannot lead to any settling inside the DHW cylinder. The resulting mixing in the standby part may lead to extremely long heat-up times and fluctuating outlet temperatures (DHW). In this case too, connecting the DHW circulation pipe to the cold water inlet may be advantageous in terms of the operating characteristics of the DHW heating system.

6.3 Preventing corrosion damage

The corrosion resistance of materials used for heating domestic hot water is critical for their service life.

Natural water reserves are no longer able to cover the demand for drinking water. Acidic and saline water are increasingly used to satisfy this demand. Particularly in the urban areas of industrial nations, water is becoming more and more corrosive.

To size and design systems that meet general and corrosion protection requirements, it is not only essential to select appropriate materials, but also to install the system correctly, taking operating conditions into consideration and performing a professional handover of the final system.

Interaction between water and materials

Materials such as copper are subject to corrosion although this will not necessarily result in damage. Damage due to corrosion only occurs when the metal in the water does not form any protective layers. The interaction between water, substances in the water and the material surface can create protective layers. These protect the metal from further attacks by the water. However, protective layers may also be destroyed by changes in the water quality. In the case of stainless steel, the alloying alone offers protection in the form of a passive layer – no protective layer created through interaction is required here.

Water temperature

Rising standards of living not only result in generally greater demands for water, but specifically also in an increased consumption of heated water.

Generally, in practical applications DHW temperatures are limited to 60 °C. The performance factors for DHW cylinders to DIN 4708 are also determined at 60 °C.

Reasons to limit the DHW temperature to no more than 60 °C:

- Energy saving
- Corrosion characteristics of the materials used
- Scaling characteristics
- Protection against scalding

Introduction of dirt

Solids borne in the water can have a negative influence on water hygiene, as well as trigger corrosion. Some supply pipes transport rust and dirt particles, which are brought into buildings through the water supply. This risk is particularly high where older supply mains are operated with higher flow velocities on account of the additional water demand through new housing estates. Deposits in the mains are dislodged and so introduce dirt into the domestic installation.

It is therefore important to always install a drinking water filter immediately downstream of the water meter in the cold water inlet. This should be cleaned regularly in line with the maintenance instructions issued by the manufacturer. The drinking water filter protects the entire pipework against floating particles. Furthermore, such filters prevent shower heads and taps from becoming clogged up, and keep the solenoid valves of washing machines, dishwashers, etc. working well.

According to current regulations (DIN 1988-200) a filter should **always** be installed immediately downstream of the water meter.

Pipework

Generally, copper and stainless steel are used as metallic pipework material.

Plastic and plastic compound pipework is also used. To ensure that the drinking water installation provides consumers with a trouble-free water supply, only materials and appliances must be used that are designed and built in accordance with accepted engineering standards. For further details see the technical requirements stipulated by DIN or DVGW. The DVGW or DIN/DVGW test mark on approved appliances indicates that the requirements of accepted engineering standards are met.

Within the limits specified by the Drinking Water Ordinance [Germany], drinking water may vary from place to place, subject to supply area or time-dependent fluctuations, such as the use of different wells. In spite of the generally well known application limits of different materials, it is frequently difficult to determine when and under what conditions the relevant material can be used. At this point, the local experience of the installer or water supply utility are highly valuable and should be taken into account.

Even for water that forms protective layers, the protection of new water pipes also essentially depends on the initial runtime following installation. Drinking water filters must be installed right from the start. During commissioning, all contamination caused by the installation work must first be flushed out of the lines. The aforementioned regulations specify the requirements for the flushing process. Flowing water is better at forming a protective layer than standing water: Immediately after the pipework has been filled for the first time, ensure on-going water consumption.

Also ensure that there are no long delays between the initial filling for pressure testing (with filtered water) and final commissioning, as partial filling of the pipes could result in the formation of different protective layers.

Copper pipes

Copper pipes are widely used in domestic installations because of their useful properties. Copper is a material that builds up a protective layer in drinking water and in doing so protects itself against corrosion.

Installation — DHW cylinders (cont.)

The influence that water quality has on the likelihood of corrosion depends on the type of corrosion. Soft water rich in carbonic acid and with a high sulphate content encourages corrosive reactions. During installation, for copper pipes up to and including sizes 28 x 1.5 mm, heat treatment in excess of 400 °C is not permissible. In other words, brazing, hot bending or annealing for swaging or flaring is not permissible.

During commissioning, ensure that the system is adequately flushed, since residual foreign bodies can interfere with the formation of the protective layer. Partial filling, which may occur between the pressure test with water and commissioning as a result of incomplete draining, could lead to the formation of different protective layers or a three-phase transition. This may have a negative influence on the formation of the protective layer.

Flowing water is better at forming a protective layer than standing water.

Observe the maximum permissible flow velocity; see DIN 1988-300. Brass and gunmetal are classed as copper materials. Removal of zinc from brass is rarely observed. Local experience is invaluable.

Rules on protecting copper pipes against corrosion

1. Only install copper pipes with the kind of water that forms protective layers. Expert installation essential
2. Install effective drinking water filters.
3. Use only pipes manufactured according to recognised standards.
4. Commission the system carefully, including adequate flushing.

Stainless steel pipes

On account of its corrosion-specific and hygienic properties, stainless steel is near perfect for contact with drinking water, which is essential for our lives.

DHW cylinders made from stainless steel

Choosing the correct material for DHW cylinders provides greater security against corrosion attack by drinking water.

Viessmann has worked intensively on the development of DHW cylinders. Over many years, a number of materials and measures to guard against corrosion have been impartially researched.

Viessmann DHW cylinders are made from stainless steel material no. 1.4521 and 1.4571, which have stood the test of time over decades.

Stainless steel DHW cylinders from Viessmann are the result of intensive development work, supplemented by practical applications over many years.

Using stainless steel for maximum protection against corrosion is not the only critical factor. It is just as important that the corrosion resistance of the material remains unaffected by all production processes. This requirement results in design and production guidelines that enable the creation of a DHW cylinder that is reliably protected against corrosion and offers a long service life.

For common stainless steels containing molybdenum, application limits concerning permissible substances in water are not specified. Stainless steel is completely neutral in all water with pH values from 4 to 10. However, according to the Drinking Water Ordinance [Germany], the pH value may only be between 6.5 and 9.5.

The application limits defined by the manufacturers with regard to the chloride content must be observed.

Rules for the installation of stainless steel pipes

1. Professional installation, processing/handling appropriate for stainless steel
2. Install effective drinking water filters.
3. Use only pipes manufactured according to recognised standards.
4. Commission the system carefully, including adequate flushing.

Plastic pipes

A large number of pipework systems made from different plastic materials is offered in the drinking water sector, including plastic/metal composite pipes. These materials are subject to different conditions, particularly during installation, which must be taken into consideration. For example, linear expansion, suitability for cold water and/or hot water installations, joining and fixing methods, commissioning conditions and flushing processes. Furthermore, transport and storage conditions must also be taken into account. Always observe the manufacturer's instructions.

Generally, only products with recognised test marks must be used for this, e.g. DVGW test mark. This ensures that the pipes meet the hygiene recommendations for materials in contact with drinking water, as issued by the Plastics Commission of the Federal Department for Health [Germany].

To ensure consistent quality, production processes are largely automated.

The high demands Viessmann makes when selecting materials, coupled with careful manufacture geared to suit stainless steel, have led to the production of several hundred thousand DHW cylinders that perform well even under extreme operating conditions. Stainless steel permits the connection of all pipework materials that are suitable for drinking water without reservation, subject to the application limits prescribed by the water and operating conditions.

Stainless steel DHW cylinders from Viessmann stand out on account of the following characteristics:

- Homogeneous surface
- Hygienic thanks to mirror-finish surfaces
- Bacteria-neutral due to stainless steel
- No sedimentation; resistant surfaces

DHW cylinders made from steel with Ceraprotect enamel coating and cathodic corrosion protection

Ceraprotect enamelling is a coating that is highly resistant to corrosion attack and is made from vitreous material. The walls of the smooth Ceraprotect enamelling resist scale build-up.

In addition, this DHW cylinder is equipped with a protective anode. This is available as a protective magnesium anode or a maintenance-free impressed current anode.

This protective system not only meets but exceeds the requirements of DIN 4753. As a result, this system is suitable for all drinking water with conductivity > 100 µS/cm.

Plate heat exchangers made from stainless steel, copper brazed

Thanks to their efficient heat exchanger surfaces, plate heat exchangers provide hot water on a small footprint and only on demand. The heat exchanger plates are made from material no. 1.4401. This is a stainless steel similar to 1.4571 and 1.4521 commonly used in cylinder manufacture and therefore offers the same favourable properties.

The heat exchanger plates are brazed with copper. As a result, the Drinking Water Ordinance [Germany] as well as the requirements of the familiar DIN standards on working with copper pipes must be observed with regard to water quality and corrosion. For example, the likelihood of corrosion increases with a rising concentration of sulphates or natural carbonic acid.

As a result of the copper braze, the flow rule in connection with galvanised pipes must also be observed.

Installation — DHW cylinders (cont.)

In the case of very hard water with a total hardness level in excess of 20 °dH (total of alkaline earths 3.5 mol/m³), we recommend the installation of DHW cylinders with internal indirect coils. In the case of plate heat exchangers, limescale deposits lead to reduced output and eventually to troublesome flow noise. In extreme cases, the heat exchanger channels can close up completely.

Alternatively, the correct drinking water quality can be ensured by means of a suitable water treatment facility that should be professionally installed and maintained.

Note

The text above makes reference to DIN 1988. DIN 1988 in the form of the "Technical rules for drinking water installations (TRWI)" represents the latest engineering standards. It is split into 5 sections.

Sections of DIN 1988/TRWI

DIN 1988	Technical rules for drinking water installations (TRWI)
Part 100	Protection of drinking water, maintaining drinking water quality, technical rules of the DVGW
Part 200	Installation type A (sealed unvented system) – engineering, components, equipment, materials, technical rules of the DVGW
Part 300	Calculating pipe diameters, technical rules of the DVGW
Part 500	Pressure raising systems with variable speed pumps, technical rules of the DVGW
Part 600	Drinking water installations in conjunction with fire fighting and fire safety systems, technical rules of the DVGW

As the details on "Protection of drinking water, maintaining drinking water quality" provide an assurance of hygiene that is legally binding and in the public interest, you must observe and comply with these associated regulations and guidelines.

We would also draw your attention to the information on electrical safety measures and limiting water hammer. To prevent other kinds of damage, these guidelines also serve to assure further protection against corrosion:

- Since insulation sections are fitted in domestic supply pipes, ensure that the electrical safety measures [earthing] remain effective. Otherwise, electrical potential could build up in parts of the system that channel water and are susceptible to corrosion.
- Limiting water hammer reduces the risk of protective layers that have built up being shaken loose.

7.1 Questionnaire regarding the sizing of DHW cylinders

DHW cylinders in DHW heating systems

1. Address

Name	Required cylinder temperature	°C
Street	Flow temperature of the heat source	°C
Postcode / Town	Spread (Δt)	<input type="checkbox"/> Optimised K
Telephone (for any queries)		
Date	<input type="checkbox"/> Required heating output is calculated with the calculation program: See https://cylinder-planner.ca.viessmann.com .	
Project	<input type="checkbox"/> Max. available heating output	KW

2. Essential details

3. Selection of calculation method

Residential units

Type of residential unit	N_L factor	Quantity
1-2 room studio apartment with shower	0.71	
3-room apartment with standard bath	0.77	
Standard residential unit with standard bath	1.00	
Standard residential unit with deluxe bath	1.12	
Deluxe apartment with standard bath and shower	1.63	
Standard residential unit with guest room	1.89	
Other		

Hotels and guest houses

Equipment	Demand (kWh)	Quantity
Single room with 1 bath and 1 washbasin	7.0	
Single room with 1 shower and 1 washbasin	3.0	
Single room with 1 washbasin	0.8	
Double room with 1 bath and 1 washbasin	10.5	
Double room with 1 shower and 1 washbasin	4.5	
Double room with 1 washbasin	1.2	
Covers	0.6	

Hotel category (star rating)	
Demand period	Hours
Heat-up time	Hours

Catering businesses (e.g. restaurant, canteen, dining hall)

Location of catering facilities	<input type="checkbox"/> Restaurant	<input type="checkbox"/> Canteen	<input type="checkbox"/> Other
Number of covers	Number of draw-off points	DHW demand	l/cover
		Demand period	Hours

Hospitals and clinics

Number of beds	DHW demand (45 °C)	l/bed
Number of additional draw-off events	DHW demand (45 °C)	l/draw-off event
Total number of draw-off points	Demand period	Hours

Shared accommodation (e.g. residential home, army barracks)

Number of occupants	Shower frequency	Number of users/hour and shower
Number of showers	DHW demand (45 °C)	l/shower taken
Number of additional draw-off events	DHW demand	l/draw-off event
Number of additional draw-off events		

Appendix (cont.)

Retirement home, nursing home

Number of beds	DHW demand (45 °C)	l/bed
Number of covers	DHW demand (45 °C)	l/cover
Number of additional draw-off points	Demand period	Hours
Number of draw-off points per room		

Campsite, recreational camp

Number of campers	Shower frequency	Number of users/hour and shower
Number of showers	DHW demand	l/shower taken
Number of additional draw-off points	DHW demand (45 °C)	l/draw-off point

Leisure facilities (e.g. sports hall, swimming pool)

Number of showers	Heat-up time	min
Demand period	min	Shower time
DHW demand/shower (40 °C)	l/min	

Commercial enterprises

Number of employees	Activity	<input type="checkbox"/> Slightly dirty	<input type="checkbox"/> Moderately dirty	<input type="checkbox"/> Very dirty
Consumption point	DHW volume (l/min)	Quantity		
Washbasins with tap	8.50			
Washbasins with spray head	4.50			
Circular communal washbasin for 6 people	20.00			
Circular communal washbasin for 10 people	25.00			
Shower unit without changing cubicle	9.50			
Shower unit with changing cubicle	9.50			
Demand period		Hours		
Heat-up time		Hours		

4. Selected DHW cylinder

Vitocell 100, type:

Vitocell 300, type:

7.2 Checklist for heat exchanger enquiries/sizing

Intended use: Water/water

<input type="checkbox"/>	System separation, underfloor heating system		
<input type="checkbox"/>	System separation, district heating system		
<input type="checkbox"/>	DHW heating		
<input type="checkbox"/>	Other:		
System temperatures			
Primary		Secondary	
Inlet	°C	Inlet	°C
Outlet	°C	Outlet	°C
Output	kW		
Limits (e.g. max.)			
Pressure drop			
Primary	mbar kPa	Secondary	mbar kPa
Limits			
Pressure levels	bar MPa		
Limits			
Temperatures	°C		
Special conditions?			
Specification of heat exchanger type			
<input type="checkbox"/>	System separation, underfloor heating system		
<input type="checkbox"/>	System separation, district heating system		

7.3 Checklist for heat exchanger enquiries/sizing

Intended use: Steam/water

- System separation, district heating system
 Other:

Saturated steam pressure/system temperatures

Primary		Secondary	
Steam pressure	bar	Inlet	°C
	MPa		
Condensate outlet	°C	Outlet	°C
Output	kW		

Limits (e.g. max.)

Primary		Secondary	
Pressure drop	mbar		mbar
	kPa		kPa

Limits

Pressure levels	bar		
	MPa		

Limits

Temperatures	°C		
--------------	----	--	--

Special conditions?

Specification of heat exchanger type

Tubular heat exchanger

- Vertical
 Horizontal (Viessmann only supplies vertical version)

Keyword index

B		S	
Boiler supplement Zk.....	18	Safety valve.....	34
C		Selection diagrams, DHW cylinder.....	9, 10, 12
Calculation of the cylinder loading system.....	32	Selection of DHW cylinder	
Calculation program.....	15	– According to continuous output.....	14
Checklist for heat exchanger enquiries/sizing.....	44	– According to demand factor N.....	9
Circulation pump for cylinder heating, sizing.....	25	Shut-off valves.....	34
Corrosion damage.....	39	Sizing	
Cylinder loading system, calculation.....	32	– According to continuous output.....	25
Cylinder loading system, function description.....	29	– According to peak flow rate.....	23
Cylinder loading systems.....	28	Sizing DHW cylinders.....	15
D		Sizing of DHW cylinders, questionnaire.....	42
Demand factor N, calculating.....	16	V	
DHW circulation pipes.....	38	Vitotrans 353.....	7, 14, 23
DHW connection.....	34		
DHW demand in commercial enterprises.....	19		
DHW demand in commercial saunas.....	20		
DHW demand in hotels, guest houses and residential homes.....	19		
DHW demand in residential buildings.....	15		
DHW demand in sports halls.....	21		
DHW side connection of cylinder banks.....	36		
DHW side connection of the Vitotrans 222.....	37		
DHW side connection to DIN 1988.....	35		
DIN 4708-2.....	15		
Drain valve.....	34		
Draw-off demand.....	16		
Drinking water filter.....	34		
F			
Flow regulating valve.....	34		
Freshwater module.....	7, 14, 23		
H			
Heat demand			
– For DHW in commercial enterprises.....	19		
– For DHW in commercial saunas.....	20		
– For DHW in hotels, guest houses and residential homes.....	19		
– For DHW in residential buildings.....	15		
– For DHW in sports halls.....	21		
Heating output, calculating.....	19		
Heating water flow rate calculation.....	25		
Heating water side, flow rate calculation.....	27		
Heating water side, pressure drop calculation.....	25		
Heat-up output, calculating.....	20, 22		
I			
Installation, DHW cylinders.....	34		
N			
Non-return valve.....	34		
O			
Occupancy factor p, calculating.....	15		
Overview of product features.....	8		
P			
Pressure gauge.....	34		
Pressure reducer.....	34		
Product features, overview.....	8		
Product information.....	5		
Q			
Questionnaire, DHW cylinder sizing.....	42		



Subject to technical modifications.

Viessmann Climate Solutions SE
35108 Allendorf / Germany
Telephone: +49 6452 70-0
Fax: +49 6452 70-2780
www.viessmann.com

Viessmann Limited
Hortonwood 30, Telford
Shropshire, TF1 7YP, GB
Telephone: +44 1952 675000
Fax: +44 1952 675040
E-mail: info-uk@viessmann.com

5414646