

CATALOGUE THERMOHYDRAULICS

STORAGE
HEATING
COOLING
SOLAR

BLADDER AUTOCLAVES FOR SANITARY WATER

MULTI-FUNCTIONAL TANKS

EXPANSION TANKS FOR HEATING

TANKS FOR SOLAR SYSTEMS

PLASTO - POLYETHYLENE STORAGE TANKS
FOR ABOVE GROUND

PLASTO - POLYETHYLENE STORAGE TANKS
FOR UNDERGROUND & WASTEWATER TREATMENT

GALVANIZED/GLASSLINED TANKS

HOT WATER TANKS

ASME TANKS



APPLICATIONS

GLASSLINED CYLINDER FOR HEAT PUMP

BSP

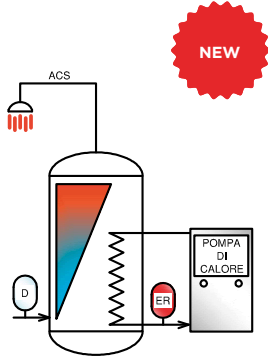

THERMAL FLYWHEEL WITH SINGLE HEAT EXCHANGER

PUFFER S1

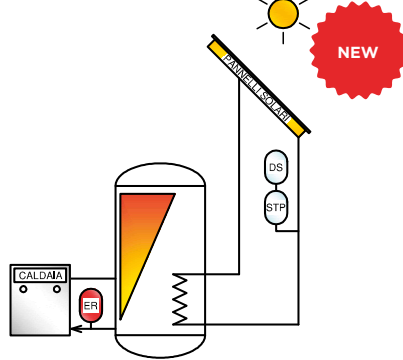

THERMAL FLYWHEEL WITH 2 HEAT EXCHANGERS

PUFFER S2

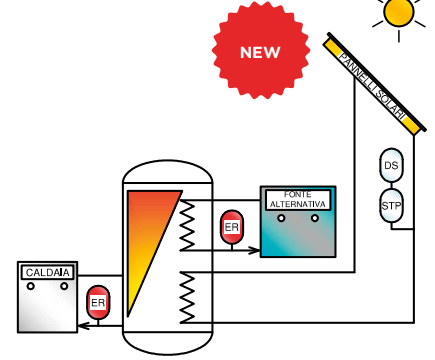

COMBI

CMS - STANDARD

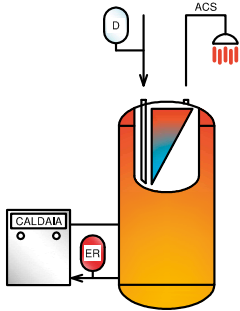

CMP - PLUS

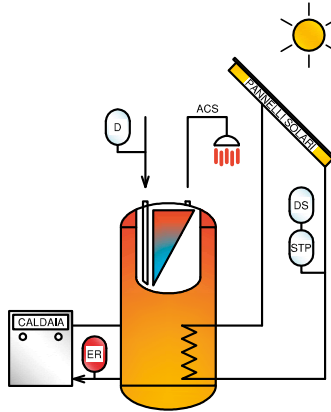

DHW CYLINDER WITH 2 HEAT EXCHANGERS

BST / BXT / BF-2 / BG

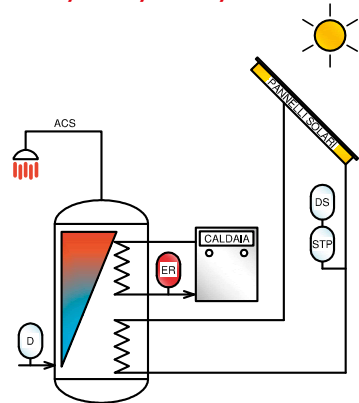

DHW CYLINDER WITH 1 HEAT EXCHANGER

BSH HORIZONTAL

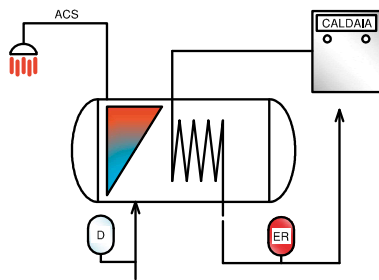

BSV / BSM / BXV / BF-1 / BG

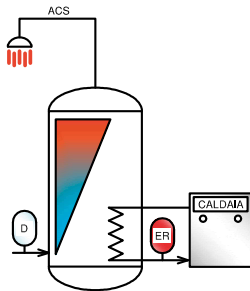

DHW CYLINDER WITH 3 HEAT EXCHANGERS

BF-3 / BG

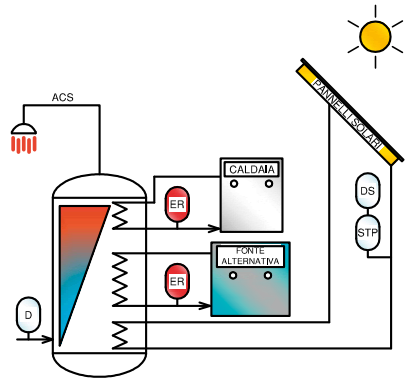

COMBI QUICK

CQS - STANDARD

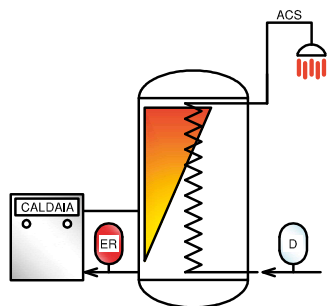

CQP - PLUS

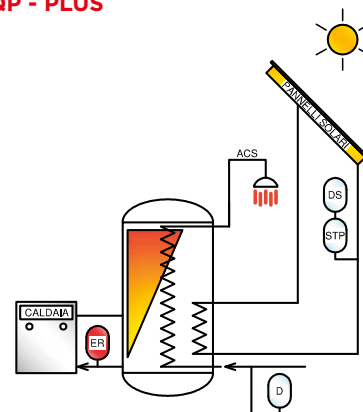

CQT - TWIN

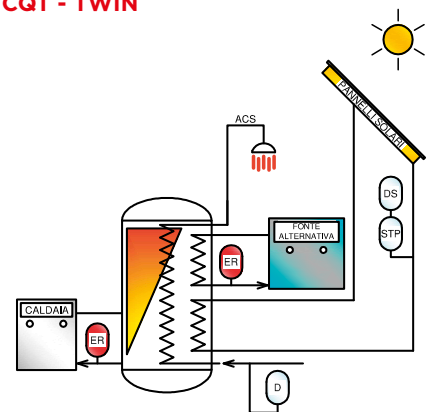



BSM

HIGH PERFORMANCES GLASSLINED CYLINDER

WITH FIXED HEAT EXCHANGER FOR SANITARY HOT WATER (150 - 1000 LITRES)

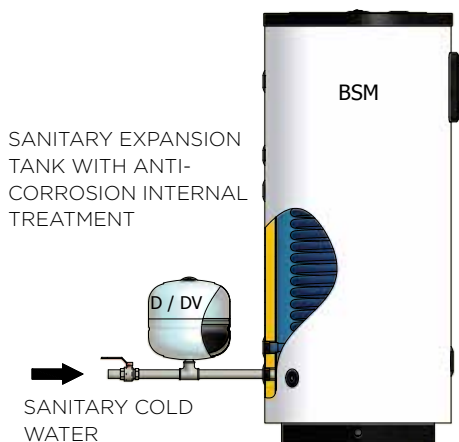

BSM 150 - 200

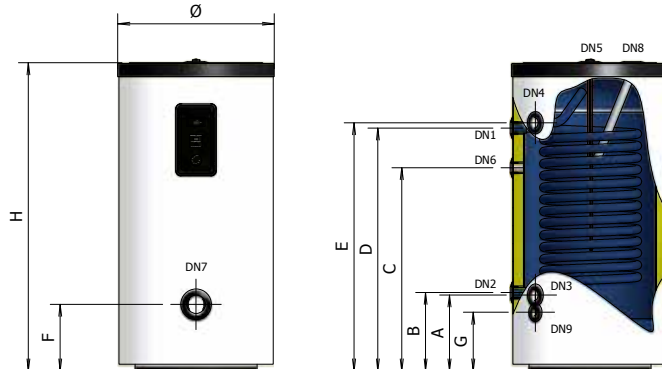

BSM 300 - 1000

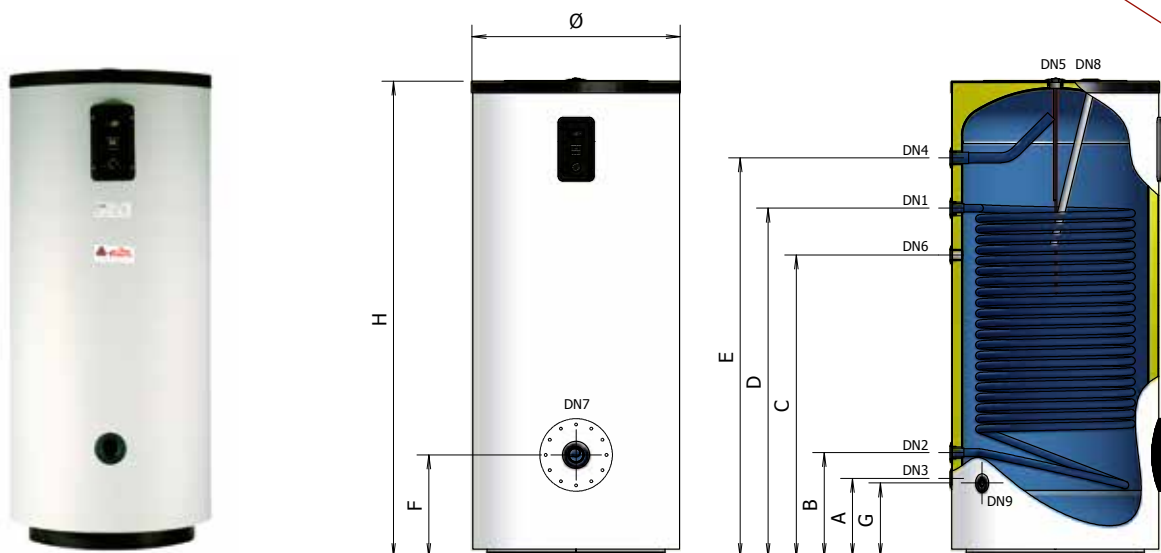

KEYWORD

DN1: Primary fluid inlet, heat exchanger side; **DN2:** Primary fluid outlet, heat exchanger side; **DN3:** Sanitary cold water inlet; **DN4:** Sanitary hot water outlet; **DN5:** Probe (Thermometer, thermostat); **DN6:** Recirculation; **DN7:** Heating element/Visual indicator light; **DN8:** Magnesium anode; **DN9:** Drain



CYLINDER



FOR SANITARY HOT WATER



SUITABLE FOR SOLAR SYSTEMS



ANODE WITH TESTER



INTERNAL, ANTI-CORROSION GLASSLINING TREATMENT



POLYURETHANE INSULATION



THERMOMETER



THERMOSTAT



+ 95°C
CYLINDER
MAX TEMPERATURE



+ 110°C
MAX TEMPERATURE OF
EXCHANGER

P_{MAX} 10 bar
MAX WORKING PRESSURE

P_{SCA} 12 bar
MAX PRESSURE
OF EXCHANGER

WARRANTY: 5 YEARS

REFERENCE STANDARDS

CYLINDER:

2014/68/UE Directive - ART. 4.3, without CE marking
Standard EN 12897:2016

Designed and built in accordance with the requirements of the 2009/125/EC.

Labeling in accordance with the requirements of the 2010/30/EU.

INTERNAL GLASSLINING:

DIN 4753

The glasslining treatment makes the cylinder suitable to contain hot water for sanitary and hygienic use and resistant to corrosive phenomena.

INSULATION:

Expanded polyurethane without CFC and HCFC.



HEAT EXCHANGER:

fixed single tube coil

INSTALLATION:

- traditional boilers (wall-hung and/or floor-standing)
- condensing boilers
- solar thermal systems

DIMENSIONS

MODEL	CODE	ENERGY LABEL		HEAT EXCHANGER 					NOTES
				CL	LITRES	m ²	LITRES		
BSM-150	A3COL43 PGP40	C		150	1,10	7	600	950	
BSM-200	A3COL47 PGP40	C		200	1,60	10	600	1170	
BSM-300	A3COL51 PGP40	C		300	1,90	11	650	1400	
BSM-400	A3COL53 PGP40	D		400	2,10	13	750	1445	
BSM-500	A3COL55 PGP40	D		500	2,70	17	750	1695	
BSM-800	A3COL60 PGP40	/		800	3,50	21	900	1795	
BSM-1000	A3COL62 PGP40	/		1000	4,50	28	900	2045	
BSM-800+FL. (*)	A3C1L60 SWS50	/		800	3,50	21	900	1795	
BSM-1000+FL. (*)	A3C1L62 SWS50	/		1000	4,50	28	900	2045	

(*) Flange version

MODEL	A mm	B mm	C mm	D mm	E mm	F mm	G mm
BSM-150	290	275	590	715	720	250	225
BSM-200	290	300	770	920	940	255	225
BSM-300	260	365	890	1030	1160	310	245
BSM-400	280	385	850	960	1180	330	265
BSM-500	280	385	1000	1140	1430	330	265
BSM-800	340	450	995	1270	1460	440	320
BSM-1000	340	450	1295	1495	1710	440	320
BSM-800+FL.	340	450	995	1270	1460	435	320
BSM-1000+FL.	340	450	1295	1495	1710	435	320

MODEL	ANODE ø x ø conn. x L	DN1	DN2	DN3	DN4	DN5	DN6	DN7	DN8	DN9
BSM-150	32 x 1.1/4" x 350	1"	1"	1"	1"	1"1/4	3/4"	2"	1"1/4	1/2"
BSM-200	32 x 1.1/4" x 350	1"	1"	1"	1"	1"1/4	3/4"	2"	1"1/4	1/2"
BSM-300	32 x 1.1/4" x 550	1"	1"	1"	1"	1"1/4	3/4"	2"	1"1/4	1/2"
BSM-400	32 x 1.1/4" x 550	1"	1"	1"	1"	1"1/4	3/4"	2"	1"1/4	1/2"
BSM-500	32 x 1.1/4" x 700	1"	1"	1"	1"	1"1/4	3/4"	2"	1"1/4	1/2"
BSM-800	32 x 1.1/4" x 700	1"1/4	1"1/4	1"1/4	1"1/4	1"1/4	1"	2"	1"1/4	3/4"
BSM-1000	32 x 1.1/4" x 700	1"1/4	1"1/4	1"1/4	1"1/4	1"1/4	1"	2"	1"1/4	3/4"
BSM-800+FL.	32 x 1.1/4" x 700	1"1/4	1"1/4	1"1/4	1"1/4	1"1/4	1"	Øi 220	1"1/4	3/4"
BSM-1000+FL.	32 x 1.1/4" x 700	1"1/4	1"1/4	1"1/4	1"1/4	1"1/4	1"	Øi 220	1"1/4	3/4"

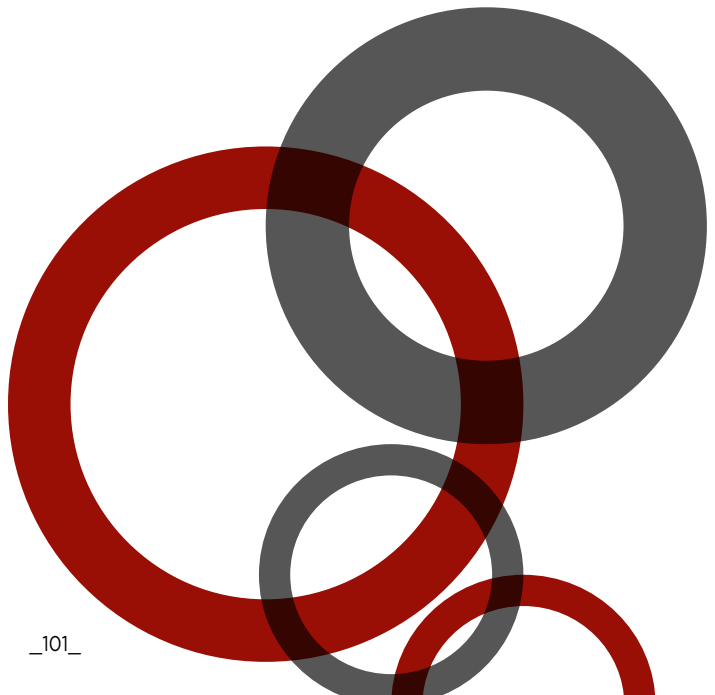

TECHNICAL CHARACTERISTICS

MODEL	MAX WORKING PRESSURE CYLINDER (Secondary circuit)	MAX. WORKING PRESSURE HEAT EXCHANGER (Primary circuit)	HEAT EXCHANGER PRESSURE DROP
BSM 150	10 bar	12 bar	50 mbar
BSM 200			105 mbar
BSM 300			200 mbar
BSM 400			250 mbar
BSM 500			500 mbar
BSM 800			150 mbar
BSM 1000			325 mbar

MODEL	INSULATION TYPE	INSULATION THICKNESS	INSULATION DENSITY	INITIAL THERMAL CONDUCTIVITY	(*) INSULATION THERMAL LOSS	EXTERNAL COVER
BSM 150	95% closed cells rigid expanded polyurethane, CFC - HCFC free	50 mm	40 kg/m ³	23,5 mW/m K	1,752 kWh / 24h	Grey polystyrene RAL 9006
BSM 200					1,992 kWh / 24h	
BSM 300					2,208 kWh / 24h	
BSM 400					2,856 kWh / 24h	
BSM 500					3,192 kWh / 24h	
BSM 800					3,958 kWh / 24h	
BSM 1000					4,449 kWh / 24h	

(*) Thermal loss calculated with an accumulation temperature equal to 65 °C and with an external temperature equal to 20 °C.

STANDARD EQUIPMENT

- Anoder tester
- Thermometer
- Thermostat

SAFETY DEVICES

The cylinders must be protected from the effects of over pressure by installing:

- A **SAFETY VALVE** calibrated to a pressure lower than the max. pressure of the cylinder;
- A **SANITARY EXPANSION TANK** model **ELBI D - DV series**

MODEL	RECOMMENDED SANITARY EXPANSION TANK (mod. ELBI D-DV series)
BSM 150	D - 11
BSM 200	D - 18
BSM 300	D - 24
BSM 400	D - 35
BSM 500	D - 35
BSM 800	DV - 50
BSM 1000	DV - 80

Tank sized using the following parameters: T. accumulation= 85 °C / T. inlet = 15 °C / Pre-charge pressure = 3 bar / Max pressure = 6 bar
The recommended capacity must be verified on the basis of the actual dimensions of the system implemented

MODEL	MAGNESIUM ANODE SUPPLIED	CATHODIC PROTECTION APPLICABLE
BSM 150	1,1/4" x 350 / Cod.8560046	Cathodic protection with cylinders 100/300 l. Code 8560170
BSM 200	1,1/4" x 350 / Cod.8560046	
BSM 300	1,1/4" x 550 / Cod.8560066	
BSM 400	1,1/4" x 550 / Cod.8560066	
BSM 500	1,1/4" x 700 / Cod.8560086	
BSM 800	1,1/4" x 700 / Cod.8560086	Cathodic protection with cylinders 500/1000 l. Code 8560175
BSM 1000	1,1/4" x 700 / Cod.8560086	

THERMAL YIELD

ACCUMULATION AT 60 °C

HEAT EXCHANGER: $T_{inlet} = 80^{\circ}\text{C}$; $\Delta T = 10^{\circ}\text{C}$.

STORAGE WATER HEATER: $T_{inlet} = 15^{\circ}\text{C}$; $T_{accumulation} = 60^{\circ}\text{C}$

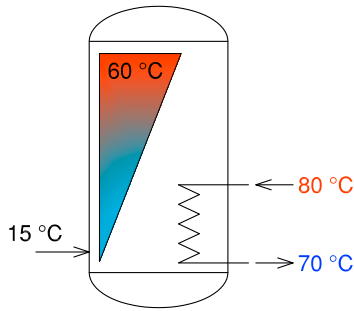

MODEL CYLINDER	THERMAL POWER [kW]	PUMP CAPACITY [l/hour]	HEATING TIME ⁽¹⁾ [min]	PRODUCTION DHW AT 60°C [l/hour]	QUANTITY DHW AT 45°C FOR FIRST 10 min. ⁽²⁾ [l]
BSM 150	22,20	1980	25	425	220
BSM 200	31,90	2800	21	610	265
BSM 300	41,60	3600	21	790	350
BSM 400	44,70	3900	29	860	435
BSM 500	57,40	5000	27	1095	530
BSM 800	70,50	6200	35	1345	750
BSM 1000	93,00	8100	32	1775	940

(1) Time required to bring the temperature of the cylinder from 15 °C to 60 °C

(2) Quantity of DHW (Sanitary Hot Water) at 45°C available in first 10 minutes with accumulation of DHW at 60° C.

ACCUMULATION AT 45 °C

HEAT EXCHANGER: $T_{inlet} = 80^{\circ}\text{C}$; $\Delta T = 10^{\circ}\text{C}$.

STORAGE WATER HEATER: $T_{inlet} = 15^{\circ}\text{C}$; $T_{accumulation} = 45^{\circ}\text{C}$.

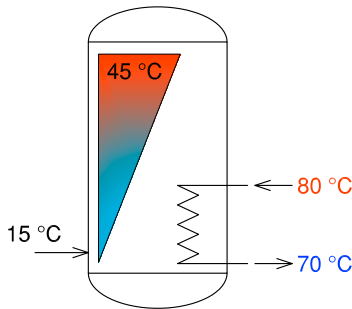

MODEL CYLINDER	THERMAL POWER [kW]	PUMP CAPACITY [l/hour]	HEATING TIME ⁽¹⁾ [min]	PPRODUCTION DHW AT 45°C [l/hour]
BSM 150	27,90	2450	14	798
BSM 200	34,00	2990	14	970
BSM 300	44,50	3910	14	1275
BSM 400	47,80	4200	19	1370
BSM 500	60,50	5320	18	1730
BSM 800	76,50	6700	22	2190
BSM 1000	100,00	8800	20	2860

(1) Time required to bring the temperature of the cylinder from 15 °C to 45 °C

TABLE OF HEATING ELEMENT APPLICABILITY TO CYLINDERS

Heating element model					Water heating time from 15° C to 60 °C (expressed in minutes) <i>The heating times outlined are approximate</i>							
CODE	Power (kW)	Voltage (Volt)	Connection	Length (mm)	BSM-150	BSM-200	BSM-300	BSM-400	BSM-500	BSM-800	BSM-1000	
8601000	1	220 V / MF	G 1.1/4"	295	480 min.	630 min.	960 min.	1270 min.	1580 min.	2520 min.	3150 min.	
8601650	1.65	220 V / MF	G 1.1/4"	450	285 min.	380 min.	580 min.	770 min.	970 min.	1550 min.	1920 min.	
8602000	2	220 V / MF	G 1.1/4"	515	n.a.	n.a.	n.a.	640 min.	800 min.	1270 min.	1580 min.	
8602600	2.6	220 V / MF	G 1.1/4"	675	n.a.	n.a.	n.a.	n.a.	n.a.	980 min.	1230 min.	
8602601	2.6	220 V / MF	G 1.1/4"	360	180 min.	250 min.	370 min.	490 min.	630 min.	980 min.	1230 min.	
8603300	3.3	220 V / MF	G 1.1/4"	825	n.a.	n.a.	n.a.	n.a.	n.a.	n.a.	n.a.	
8603301	3.3	220 V / MF	G 1.1/4"	435	145 min.	200 min.	295 min.	390 min.	490 min.	780 min.	980 min.	
8604001	4	220 V / MF	G 1.1/4"	510	n.a.	n.a.	n.a.	320 min.	410 min.	640 min.	800 min.	
8705000	5	380 V / TF	G 1.1/2"	445	95 min.	140 min.	200 min.	260 min.	330 min.	520 min.	640 min.	
8706000	6	380 V / TF	G 1.1/2"	510	n.a.	n.a.	n.a.	220 min.	280 min.	430 min.	540 min.	
8708000	8	380 V / TF	G 1.1/2"	670	n.a.	n.a.	n.a.	n.a.	n.a.	330 min.	420 min.	
8710000	10	380 V / TF	G 1.1/2"	820	n.a.	n.a.	n.a.	n.a.	n.a.	n.a.	n.a.	
8712000	12	380 V / TF	G 1.1/2"	970	n.a.	n.a.	n.a.	n.a.	n.a.	n.a.	n.a.	

n.a.= Heating element not applicable

SEE TABLE OF SYMBOLS
IN THE SHUTTER OF THE
COVER

