

Planning and Calculation



Planning and Calculation

Selection of the most suitable products for pressure maintenance, degassing and water make-up

Planning and Calculation

Reliable pressurisation and quality water are the basic requirements for a gentle and trouble-free operation of waterborne heating, solar and cooling systems. Our planning and calculation basics support you in choosing the right products, their size and performance.

Table of contents

General Calculations	3
Statico - Expansion vessels with fixed air cushion	8
Quick selection	9
Application examples	11
Simply Compresso - Pressure maintenance systems with compressors	12
Quick selection	13
Application examples	14
Compresso - Pressure maintenance systems with compressors	16
Quick selection	18
Application examples	19
Transfero TV - Pressure maintenance system with pumps	21
Quick selection TV	22
Application examples TV	24
Transfero TVI - Pressure maintenance system with pumps for high pressure demands	25
Quick selection TVI	26
Application examples TVI	27
Aquapresso - Pressure stabilisation for potable water	29
Aquapresso in potable hot water systems	29
Approvals	29
Calculation	30
Quick selection	30
Aquapresso in pressure-boosting systems	30
Aquapresso A...F with bypass	30
Calculation	31
Diagrams	31
Application examples	32
Zeparo Cyclone - Dirt separator with Cyclonic technology	33
Quick selection	34
Application examples	36
Zeparo G-Force - Dirt separator with Cyclonic technology	37
Quick selection	38
Volumes and Flows	39
Application examples	40
Zeparo ZT turnable - Automatic air vents and separators	41
Diagram	41
Application examples	42
Zeparo ZU - Automatic air vents and separators	43
Diagrams	44
Application examples	45
Low-loss headers	46
Zeparo ZIO - Automatic air vents and separators	47
Volumes and Flows	48
Diagrams	48
Application examples	49
Simply Vento - Vacuum degassing system	50
Quick selection, Installation	51
Application examples	52
Vento Connect - Vacuum degassing system	53
Quick selection	54
Application examples	55
Safety technology	56
Application examples	56
Terminology	57

General Calculations

Pressure maintenance for systems TAZ ≤ 110°C

Calculation following EN 12828, SWKI HE301-01*), solar systems ENV 12977-1.
Use HySelect software or contact us for different installations.

General equations

Vs	Water capacity of the system	Heating	Vs = vs · Q	vs	Specific water capacity, table 4.
			Vs= Known	Q	Installed heat capacity
		Cooling	Vs= Known		System design, content calculation
Ve	Expansion volume	EN 12828	Ve = e · (Vs+Vhs)	e, ehs	Expansion coefficient for ts_{max} , table 1
		Cooling	Ve = e · (Vs+Vhs)	e, ehs	Expansion coefficient for ts_{max} , table 1 ⁷⁾
		SWKI HE301-01 heating	Ve = e · Vs · X¹⁾ + ehs · Vhs	e ehs	Expansion coefficient for $(ts_{max} + tr) / 2$, table 1 Expansion coefficient for ts_{max} , table 1
		SWKI HE301-01 cooling	Ve = e · Vs · X¹⁾ + ehs · Vhs	e, ehs	Expansion coefficient for ts_{max} , table 1 ⁷⁾
Vwr	Water reserve	EN 12828, cooling	Vwr ≥ 0,005 · Vs ≥ 3 L		
		SWKI HE301-01	Vwr is considered in Ve with the coefficient X		
p0	Minimum pressure ²⁾ Lower limit value for the pressure maintenance	EN 12828, cooling	p0 = Hst/10 + pv + 0,2 bar ≥ pz	Hst	Static height
		SWKI HE301-01	p0 = Hst/10 + pv + 0,3 bar ≥ pz	pz	Minimum required equipment pressure for pumps or boilers
				pv	Vapour pressure for TAZ > 100°C
pa	Initial pressure Lower threshold for an optimum pressure maintenance		pa ≥ p0 + 0,3 bar		
pe	Final pressure Upper threshold for an optimum pressure maintenance.			psvs dpsvs _c	Response pressure safety valve system Closing pressure tolerance of the safety valve
		EN 12828	pe ≤ psvs - dpsv_c	dpsvs _c = dpsvs _c =	0,5 bar for psvs ≤ 5 bar ⁴⁾ 0,1 · psvs for psvs > 5 bar ⁴⁾
		Cooling, solar	pe ≤ psvs - dpsv_c	dpsvs _c = dpsvs _c =	0,6 bar for psvs ≤ 3 bar ⁴⁾ 0,2 · psvs for psvs > 3 bar ⁴⁾
		SWKI HE301-01 heating	pe ≤ psvs/1.3 pe ≤ psvs/1.15		for psvs ≤ 3 bar ⁴⁾ for psvs > 3 bar ⁴⁾
		SWKI HE301-01 cooling, solar	pe ≤ psvs/1.3 and pe ≤ psvs - 0.6 bar		psvs ⁴⁾
Statico					
PF	Pressure factor		PF = (pe + 1)/(pe - p0)		
VN	Nominal volume of the expansion vessel ⁵⁾	EN 12828, cooling	VN ≥ (Ve + Vwr + 1,1 · Vgsolar⁶⁾ + 2³⁾) · PF	Vgsolar	Collector volume ⁶⁾
		SWKI HE301-01	VN ≥ (Ve + 2 · Vgsolar⁶⁾ + 2³⁾) · PF		

Compresso

pe	Final pressure Upper threshold for an optimum pressure maintenance		pe=pa+0,2		
VN	Nominal volume of the expansion vessel ⁵⁾	EN 12828, cooling	VN ≥ (Ve + Vwr + 1,1 · Vgsolar⁶⁾ + 2³⁾) · 1,1	Vgsolar	Collector volume ⁶⁾
		SWKI HE301-01	VN ≥ (Ve + 2 · Vgsolar⁶⁾ + 2³⁾) · 1,1		
TecBox			Q = f(Hst)	>> Quick selection Compresso	

Transfero

pe	Final pressure Upper threshold for an optimum pressure maintenance.		pe = pa + 0,4		
VN	Nominal volume of the expansion vessel ⁵⁾	EN 12828, cooling	VN ≥ (Ve + Vwr + 1,1 · Vgsolar⁶⁾) · 1,1	Vgsolar	Collector volume ⁶⁾
		SWKI HE301-01	VN ≥ (Ve + 2 · Vgsolar⁶⁾) · 1,1		
TecBox			Q = f(Hst)	>> Quick selection Transfero	

Intermediate vessels ⁵⁾

VN	Nominal volume of the expansion vessel ⁵⁾	EN 12828, cooling	VN ≥ Vs · Δe + 1,1 · Vgsolar ⁶⁾ + 2 ³⁾	Δe Vgsolar	for tr and t _{min} , table 3 Collector volume ⁶⁾
		SWKI HE301-01	VN ≥ Vs · Δe + 2 · Vgsolar ⁶⁾ + 2 ³⁾		

1) Heating, Cooling, Solar: Q ≤ 10 kW: X = 3 | 10 kW < Q ≤ 150 kW: X = (87-0,3 · Q)/28 | Q > 150 kW: X = 1,5

Geothermal probe systems: X = 2,5

2) The formula for minimum pressure p0 applies to the installation of the pressure maintenance on the suction side of the circulation pump. In case of a pressure-side installation p0 is to be increased by the pump pressure Δp.

3) Add 2 litres when a Vento is installed in the system.

4) The safety valves must operate within these limits. Use component tested and certified safety valves of type H and DGH for heating systems, type F for cooling systems, type SOL for Solar systems.

5) Please select a vessel which has an equal or higher nominal content.

6) In solar systems to ENV12977-1: collector volume Vgsolar that can evaporate when not in operation; otherwise Vgsolar = 0.

7) Max. system standstill temperature, usually 40°C for cooling applications and geothermal probes with ground regeneration, 20°C for other geothermal probes

*) SWKI HE301-01: Valid for Switzerland

HySelect calculation software is based on an advanced calculation method and database. Results may vary.

Table 1: e expansion coefficient

t (TAZ, ts _{max} , tr, ts _{min}), °C	20	30	40	50	60	70	80	90	100	105	110
e Water = 0 °C	0,0016	0,0041	0,0077	0,0119	0,0169	0,0226	0,0288	0,0357	0,0433	0,0472	0,0513
e % weight MEG*											
30 % = -14,5 °C	0,0093	0,0129	0,0169	0,0224	0,0286	0,0352	0,0422	0,0497	0,0577	0,0620	0,0663
40 % = -23,9 °C	0,0144	0,0189	0,0240	0,0300	0,0363	0,0432	0,0505	0,0582	0,0663	0,0706	0,0750
50 % = -35,6 °C	0,0198	0,0251	0,0307	0,0370	0,0437	0,0507	0,0581	0,0660	0,0742	0,0786	0,0830
e % weight MPG**											
30 % = -12,9 °C	0,0151	0,0207	0,0267	0,0333	0,0401	0,0476	0,0554	0,0639	0,0727	0,0774	0,0823
40 % = -20,9 °C	0,0211	0,0272	0,0338	0,0408	0,0481	0,0561	0,0644	0,0731	0,0826	0,0873	0,0924
50 % = -33,2 °C	0,0288	0,0355	0,0425	0,0500	0,0577	0,0660	0,0747	0,0839	0,0935	0,0985	0,1036

Table 2: pv vapour over-pressure (bar)

TAZ, °C	105	110
pv Water	0,1948	0,4196
pv % weight MEG*		
30%	0,1793	0,3864
40%	0,1671	0,3601
50%	0,1523	0,3284
pv % weight MPG**		
30%	0,1938	0,4176
40%	0,1938	0,4175
50%	0,1938	0,4174

Table 3: Δe expansion (in chilled water systems when tr < 5°C; in heating systems when tr > 70°C)

tr, °C		-35	-30	-25	-20	-15	-10	-5	0		80	90	100	105	110
Δe Water	= 0 °C	-	-	-	-	-	-	-	-	-	0,0062	0,0131	0,0207	0,0246	0,0287
Δe % weight MEG*															
30 %	= -14,5 °C	-	-	-	-	-	0,0032	0,0023	0,0012	-	0,0070	0,0145	0,0226	0,0269	0,0312
40 %	= -23,9 °C	-	-	-	0,0081	0,0069	0,0055	0,0038	0,0019	-	0,0073	0,0150	0,0231	0,0274	0,0318
50 %	= -35,6 °C	0,0131	0,0121	0,0109	0,0094	0,0076	0,0056	0,0038	0,0019	-	0,0075	0,0154	0,0236	0,0279	0,0324
Δe % weight MPG**															
30 %	= -12,9 °C	-	-	-	-	-	0,0068	0,0045	0,0023	-	0,0078	0,0163	0,0252	0,0298	0,0347
40 %	= -20,9 °C	-	-	-	0,0125	0,0099	0,0077	0,0052	0,0026	-	0,0083	0,0170	0,0265	0,0313	0,0363
50 %	= -33,2 °C	-	0,0187	0,0162	0,0137	0,0111	0,0086	0,0058	0,0029	-	0,0088	0,0179	0,0276	0,0325	0,0376

Table 4: vs approx. water capacity * of central heatings referred to the installed heat capacity Q**

ts _{max} tr	°C	90 70	80 60	70 55	70 50	60 40	50 40	40 30	35 28
Radiators	vs liter/kW	14,0	16,5	20,1	20,6	27,9	36,6	-	-
Flat radiators	vs liter/kW	9,0	10,1	12,1	11,9	15,1	20,1	-	-
Convectors	vs liter/kW	6,5	7,0	8,4	7,9	9,6	13,4	-	-
Air handlers	vs liter/kW	5,8	6,1	7,2	6,6	7,6	10,8	-	-
Floor heating	vs liter/kW	10,3	11,4	13,3	13,1	15,8	20,3	29,1	37,8

*) MEG = Mono-Ethylene Glycol

**) MPG = Mono-Propylene Glycol

***) Water capacity = heat generator + distribution net + heat emitters

Table 5: DNe standard values for expansion pipes with Statico and Compresso *

Length up to approx. 30 m	DNe	20	25	32	40	50	65	80
Heating:								
EN 12828	Q kW	1000	1700	3000	3900	6000	11000	15000
SWKI HE301-01	Q kW	300	600	900	1400	3000	6000	9000
Cooling:								
ts _{max} ≤ 50 °C	Q kW	1600	2700	4800	6300	9600	17600	24100

*) For proper operation of the devices, the specified DNe values cannot fall below.

Table 6: DNe standard values for expansion pipes with Transfero TV_*

	DNe	Hst [m]	DNd	Hst [m]	DNe	Hst [m]	DNd	Hst [m]	DNe	Hst [m]	DNd	Hst [m]
	Length up to approx. 5 m				Length up to approx. 10 m				Length up to approx. 30 m			
TV_4.1	25	all	25	all	25	all	25	all	32	all	32	all
TV_4.1 H	32	all	25	all	32	all	25	all	40	all	32	all
TV_4.2 H	32	all	25	all	50 40	<13 ≥13	25	all	50	all	32	all
TV_6.1	25	all	25	all	25	all	25	all	32	all	32	all
TV_6.1 H	32	all	25	all	40 32	<23 ≥23	25	all	50 40	<26 ≥26	32	all
TV_6.2 H	50 40	<18 ≥18	25	all	50 40	<25 ≥25	25	all	65 50	<22 ≥22	32	all
TV_8.1	25	all	25	all	25	all	25	all	32	all	32	all
TV_8.1 H	32	all	25	all	40 32	<24 ≥24	25	all	50 40	<28 ≥28	32	all
TV_8.2 H	50 40	<27 ≥27	25	all	50 40	<34 ≥34	25	all	65 50	<30 ≥30	32	all
TV_10.1	25	all	25	all	25	all	25	all	32	all	32	all
TV_10.1 H	40 32	<29 ≥29	25	all	40 32	<40 ≥40	25	all	50 40	<45 ≥45	32	all
TV_10.2 H	50 40	<44 ≥44	25	all	50 40	<52 ≥52	25	all	65 50	<48 ≥48	32	all
TV_14.1	25	all	25	all	25	all	25	all	32	all	32	all
TV_14.1 H	32	all	25	all	32	all	25	all	40 32	<80 ≥80	32	all
TV_14.2 H	50 40	<61 ≥61	25	all	50 40	<80 ≥80	25	all	65 50	<70 ≥70	32	all

*) For proper operation of the devices, the specified DNe/DNd values cannot fall below.

TV.1: 1 expansion pipe DNe, 1 connection pipe DNd due to degassing

TV.1 EH, TV.2 EH for $tr < 5^{\circ}\text{C}$ or $tr > 70^{\circ}\text{C}$: 2 expansion pipes DNe, 1 connection pipe DNd due to degassing

TV.1 EH, TV.2 EH for $5^{\circ}\text{C} \leq tr \leq 70^{\circ}\text{C}$: 1 expansion pipes DNe, 1 connection pipe DNd due to degassing

Table 6: DNe standard values for expansion pipes with Transfero TVI_*

		TVI_19.1 H	TVI_19.2 H	TVI_25.1 H	TVI_25.2 H
Length up to approx. 5 m	DNe	32	50/40	32	50/40
	Hst m	all	<128 / ≥ 128	all	< 182 / ≥ 182
	DNd	25	25	25	25
	Hst m	all	all	all	all
Length up to approx. 10 m	DNe	40/32	65/50	40/32	65/50
	Hst m	< 88 / ≥ 88	< 87 / ≥ 87	< 136 / ≥ 136	< 136 / ≥ 136
	DNd	25	25	25	25
	Hst m	all	all	all	all
Length up to approx. 30 m	DNe	50/40	65/50	50/40	65/50
	Hst m	< 101 / ≥ 101	< 134 / ≥ 134	< 150 / ≥ 150	< 188 / ≥ 188
	DNd	32	32	32	32
	Hst m	all	all	all	all

*) For proper operation of the devices, the specified DNe/DNd values cannot fall below.

TVI.1 EH, TVI.2 EH for $tr < 5^{\circ}\text{C}$ or $tr > 70^{\circ}\text{C}$: 2 expansion pipes DNe, 1 connection pipe DNd due to degassing

TVI.1 EH, TVI.2 EH for $5^{\circ}\text{C} \leq tr \leq 70^{\circ}\text{C}$: 1 expansion pipes DNe, 1 connection pipe DNd due to degassing

Table 7: DNe standard values for expansion pipes with Transfero TI *

		TI ..0.2	TI ..1.2	TI ..2.2	TI ..3.2
Length up to approx. 10 m	DNe	50	65	80	100
Length up to approx. 30 m	DNe	65	80	100	125

*) For proper operation of the devices, the specified DNe values cannot fall below.

DNe standard values for connection pipes for Simply Vento, Vento V/VI/Compact *

		Simply Vento	V 2.1	V 4.1	V 6.1	V 8.1	V 10.1	V 14.1	VI 19.1	VI 25.1
Length up to approx. 10 m	DNe	25	25	25	25	25	25	25	25	25
Length up to approx. 20 m	DNe	25	25	25	25	25	25	25	25	25
Length up to approx. 30 m	DNe	32	32	32	32	32	32	32	32	32

*) For proper operation of the devices, the specified DNe values cannot fall below.

Precision pressure maintenance

Air controlled Compresso or water controlled Transfero minimize the pressure variations between p_a and p_e .

Compresso $\pm 0,1$ bar

Transfero $\pm 0,2$ bar

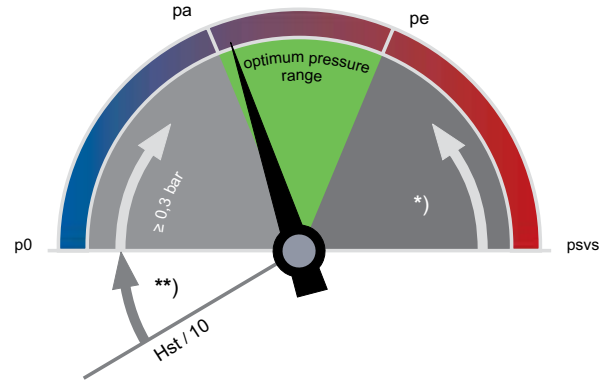

**)

EN 12828, Solar, Cooling: $\geq 0,2$ bar

SWKI HE301-01: $\geq 0,3$ bar

*)

EN 12828: $\geq psvs \cdot 0,9 \geq 0,5$ bar

Solar, Cooling: $\geq psvs \cdot 0,8 \geq 0,6$ bar

SWKI HE301-01 Heating, $psvs \leq 3$ bar: $\geq psvs / 1,3$

SWKI HE301-01 Heating, $psvs > 3$ bar: $\geq psvs / 1,15$

SWKI HE301-01 Cooling: $\geq psvs / 1,3$

p_0 Minimum pressure

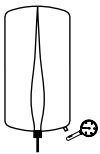

Statico

p_0 is set as pre set pressure on the gas side.

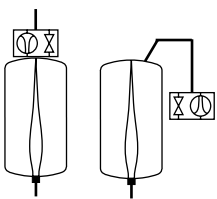

Compresso

p_0 and the switching points are calculated by the BrainCube.

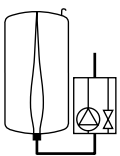

Transfero

p_0 and the switching points are calculated by the BrainCube.

p_a Initial pressure

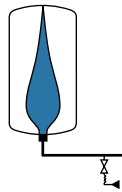

Statico

p_a is the cold fill pressure which determines the water reserve:
 $p_a \geq p_0 + 0,3$ bar;
 water make-up «on»: $p_a - 0,2$ bar.

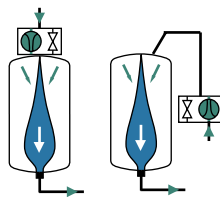

Compresso

If the system pressure is $< p_a$, the compressor starts.
 $p_a = p_0 + 0,3$

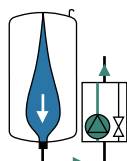

Transfero

If the system pressure is $< p_a$, the pump starts.
 $p_a = p_0 + 0,3$

p_e Final pressure

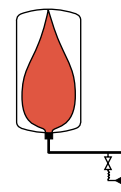

Statico

p_e is reached after heating up to ts_{max} .

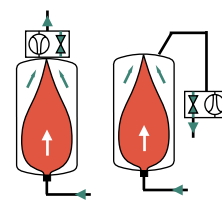

Compresso

If system pressure is $> p_e$ the air relief valve opens.
 $p_e = p_a + 0,2$

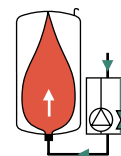

Transfero

If system pressure is $> p_e$, the relief valve opens.
 $p_e = p_a + 0,4$

Statico

The Statico range features pressure expansion vessels with fixed gas charge for heating, solar and cooling water systems. A brilliantly simple design, robust construction and operation without auxiliary power make them among the most sought-after pressure maintenance devices in the lower performance range.



Key features

- > **Airproof butyl bag according to EN 13831**
- > **Wide range of vessel sizes for different system needs**
From 8 L to 5000 L
- > **Brilliantly simple, robust design**
Operation without auxiliary power.
- > **Excellent elasticity**
Thanks to the fixed gas cushion.

Technical description

Applications:

Heating, solar and chilled water systems.

Media:

Non-aggressive and non-toxic system media.
Addition of antifreeze agent up to 50%.

Pressure:

Min. admissible pressure, PSmin: 0 bar
Max. admissible pressure, PS: see Articles

Temperature:

Max. admissible bag temperature, TB: 70 °C

Min. admissible bag temperature, TBmin: 5 °C

For PED purposes:

Max. admissible temperature, TS: 120°C

Min. admissible temperature, TSmin: -10°C

Material:

Steel. Color beryllium.
Lock shield valve DLV: Brass

Transportation and storage:

In frostless, dry places.

Standard:

Constructed according to PED 2014/68/EU.

Warranty:

Statico SD, SU: 5-year warranty for the vessel.

Statico SG: 5-year warranty for the airproof butyl bag.

Function, Equipment, Features

- Airproof butyl bag according to EN 13831 and PNEUMATEX internal standards.
- Airproof butyl bag according to EN 13831, and PNEUMATEX internal standards, exchangeable (SG).
- Feet for upright assembly (SU, SG). Wall bracket for easy assembly (SD).
- Installation with bottom, side or top connection. From 80 litres with bottom or side connection (SD).

Quick selection

Heating systems TAZ ≤ 100°C, without addition of antifreeze, EN 12828.

For exact calculations please use HySelect software.

Q [kW]	psv = 2,5 bar			psv = 3,0 bar			psv = 3,0 bar		
	Hst ≤ 7 m ≥ p0 = 1,0 bar						Hst ≤ 12 m ≥ p0 = 1,5 bar		
	Radiators 90 70	Flat radiators 90 70	Flat radiators 70 50	Radiators 90 70	Flat radiators 90 70	Flat radiators 70 50	Radiators 90 70	Flat radiators 90 70	Flat radiators 70 50
	Nominal volume VN [liter]								
10	25	25	18	25	18	18	35	25	25
15	35	25	25	25	18	18	35	35	25
20	50	35	25	35	25	25	50	35	35
25	50	35	35	50	35	25	80	50	35
30	80	50	35	50	35	35	80	50	50
40	80	50	50	80	50	35	80	80	50
50	140	80	50	80	50	50	140	80	80
60	140	80	80	80	80	50	140	80	80
70	140	80	80	140	80	80	140	140	80
80	140	140	80	140	80	80	200	140	140
90	200	140	140	140	80	80	200	140	140
100	200	140	140	140	140	80	200	140	140
150	300	200	200	200	140	140	300	200	200
200	400	300	200	300	200	200	400	300	300
250	500	300	300	400	300	300	500	400	300
300	500	400	300	400	300	300	600	400	400
400	800	500	400	600	400	300	800	500	500
500	1000	600	500	800	500	400	1000	800	600
600	1000	800	600	800	500	500	1500	800	800
700	1500	800	800	1000	600	600	1500	1000	800
800	1500	1000	800	1500	800	600	1500	1000	1000
900	1500	1000	1000	1500	800	800	2000	1500	1000
1000	2000	1500	1000	1500	1000	800	2000	1500	1500
1500	3000	2000	1500	2000	1500	1500	3000	2000	2000

Example

Q = 200 kW

psv = 3 bar

Hst = 8 m

Radiators 90 | 70 °C

Selected:

Statico SU 300.3

p0 = 1 bar

Reduce the factory set preset pressure from 1,5 bar to 1 bar!

Note for TAZ above 100 °C

Above 100°C the static height Hst decreases in the quick selection table.

TAZ = 105°C: Hst – 2 m

TAZ = 110°C: Hst – 4 m

Pre-set pressure setting p0

$p0 = (Hst/10 + pv) + 0,2$ bar

Recommended: $p0 \geq 1$ bar

Filling pressure, initial pressure

$pa \geq p0 + 0,3$ with cold, but vented system

Equipment

Lock shield valve DLV

Secured lock shield valve with draining for expansion vessels according to EN 12828, DLV 20 up to VN 800 litres, DN 40 for VN 1000 – 5000 litres to be locally supplied.

Expansion pipe

According to table 5.

Pleno

Water make-up as pressure maintenance monitoring device according to EN 12828.

Conditions:

- Pleno PIX without pump: required fresh water pressure: $w \geq p_0 + 1,7 \mid p_w \leq 10 \text{ bar}$,
- Pleno PI 9 with pump: p_a Statico within the working pressure range dpu of the Pleno.

$t_{s_{max}} \mid ^\circ\text{C}$	90	80	70	60	50	40	30	20	10
$Hst_m \mid \text{m}$	15,0	13,4	11,7	10,0	8,4	6,7	5,0	3,3	1,7

Further accessories, product and selection details:

Datasheets *Pleno*, *Vento*, *Zeparo* and *Accessories*.

Installation

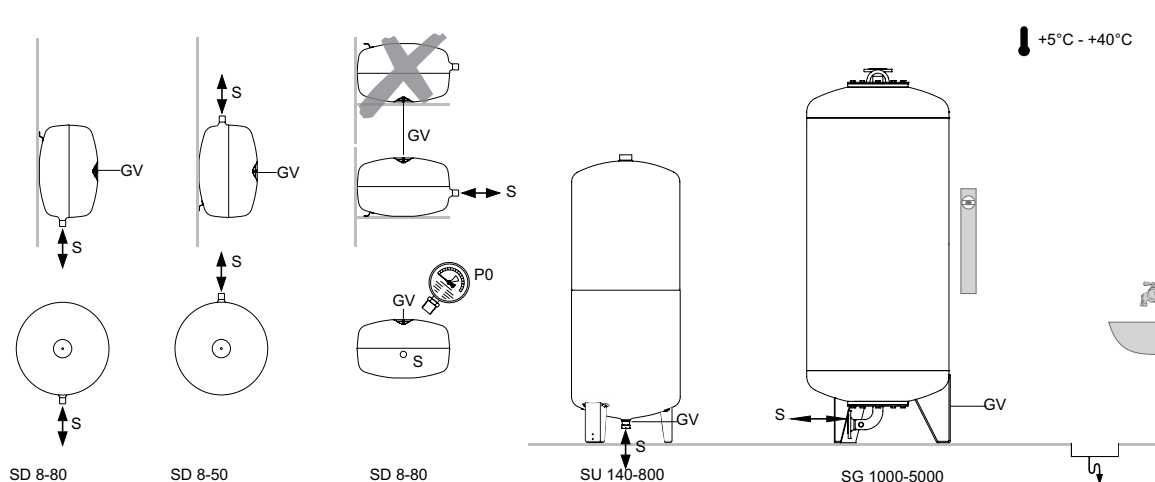

Application examples

Statico SD

For heating systems up to approx. 100 kW

(May require changes to meet local legislation)

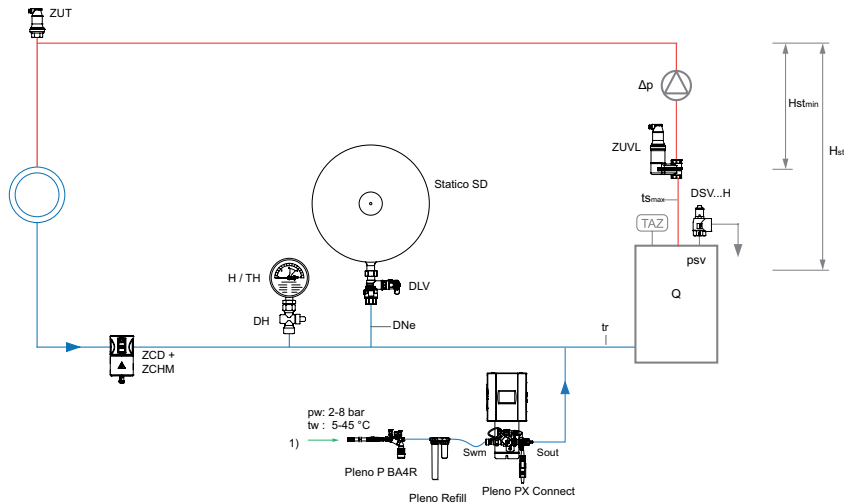

1) Water make-up connection

Pleno PIX water make-up as pressure maintenance monitoring device according to EN 12828.

Zeparo ZUV for the central separation of micro bubbles.

Zeparo Cyclone ZCDM cyclonic dirt separator with thermal insulation shells and magnets for the central capture of sludge and magnetite.

Zeparo ZUT for automatic venting during filling and during draining.

Further accessories, product and selection details: Datasheets Pleno, Zeparo and Accessories.

Statico SU

For heating system up to approx. 700 kW

(May require changes to meet local legislation)

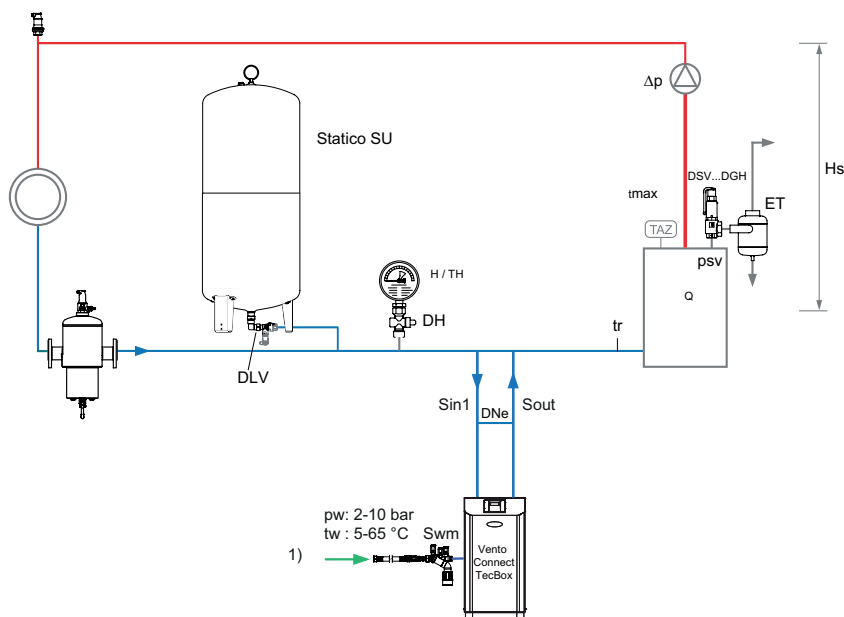

1) Water make-up connection

Vento Connect for the central venting and degassing, with water make-up as pressure maintenance monitoring device according to EN 12828.

Zeparo G-Force for the central separation of sludge.

Zeparo ZUT for automatic venting during filling and during draining.

Further accessories, product and selection details, see: Datasheet Pleno, Zeparo and Accessories.

Simply Compresso

Simply Compresso is a precision pressurisation system with a compressor and integrated expansion vessels for heating, solar and chilled water systems. Especially suitable in situations where extreme compactness, plug&play installation and full pressure control are required. Simply Compresso is the latest addition to the Compresso Connect series intended for 3 bar safety valve installations up to 400 kW in heating capacity. The **BrainCube Connect** control panel ensures a new level of connectivity, enabling communication with the BMS system and other BrainCubes, as well as remote operation of the pressurisation system through live viewing.



Key features

- > **Improved design for easier and more comfortable operation**
Resistant 3.5" TFT illuminated colour touch display. Intuitive and user friendly menu. Web based interface with remote control and live view. BrainCube Connect control panel integrated into TecBox.
- > **Plug & Play installation and start-up**
Getting the Simply Compresso up and running only takes three easy steps.
- > **Pressure maintenance with ECO-night mode**
Keeping compressor runtime to the absolute minimum.
- > **State-of-the-Art Connectivity**
Standard connections (RS485, Ethernet, USB) to BMS and remote devices, saving time during commissioning and maintenance, and allowing for control of the unit.

Technical description – Control unit TecBox

Applications:

Heating, solar and chilled water systems. For systems according to EN 12828, SWKI HE301-01, solar systems according to EN 12976, ENV 12977 with on-site excess temperature protection in case of power blackout.

Pressure:

Min. admissible pressure, PSmin: 0 bar
Max. admissible pressure, PS: 6 bar
Min. operating pressure, dpu min: 0,5 bar
Max. operating pressure, dpu max: 2,5 bar

Temperature:

Max. admissible temperature, TS: 70°C
Min. admissible temperature, TSmin: 5°C

Ambient temperature:

Max. admissible ambient temperature, TA: 40°C
Min. admissible ambient temperature, TAmin: 5°C

Accuracy:

Precision pressure maintenance $\pm 0,1$ bar.

Supply voltage:

1 x 230V (-6% + 10%) / 50/60 Hz

Electric load:

See Articles.

Enclosure class:

IP 22 according to EN 60529

Sound pressure level:

59 dB(A) / 1bar

Mechanical connections:

System connection S: G1/2"
Water make-up inlet Swm: G3/4"

Material:

Main materials include steel, brass, and bronze.

Transportation and storage:

In frostless, dry places.

Standard:

Constructed according to LV-D. 2014/35/EU
EMC-D. 2014/30/EU

Expansion vessel

Primary vessel included in TecBox. For more information see Technical description - Expansion vessels.

Quick selection

Heating systems TAZ ≤ 100°C, without addition of antifreeze

Q [kW]	Static height Hst / m	TecBox and extension vessel			
		Radiators		Flat radiators	
		90 70	70 50	90 70	70 50
Nominal volume VN [liter]					
EN12828					
< 100	18	C 2.1-80	C 2.1-80	C 2.1-80	C 2.1-80
150	18	C 2.1-80 + CD 80E	C 2.1-80 + CD 80E	C 2.1-80	C 2.1-80
200	18	C 2.1-80 + CD 80E	C 2.1-80 + CD 80E	C 2.1-80	C 2.1-80
250	18	C 2.1-80 + CD 80E	C 2.1-80 + CD 80E	C 2.1-80 + CD 80E	C 2.1-80 + CD 80E
300	18	-	-	C 2.1-80 + CD 80E	C 2.1-80 + CD 80E
350	18	-	-	C 2.1-80 + CD 80E	C 2.1-80 + CD 80E
400	16.6	-	-	C 2.1-80 + CD 80E	C 2.1-80 + CD 80E
SWKI HE301-01					
< 100	17	C 2.1-80 + CD 80E	C 2.1-80 + CD 80E	C 2.1-80	C 2.1-80
150	17	C 2.1-80 + CD 80E	C 2.1-80 + CD 80E	C 2.1-80	C 2.1-80
200	17	C 2.1-80 + CD 80E	C 2.1-80 + CD 80E	C 2.1-80 + CD 80E	C 2.1-80 + CD 80E
250	17	-	-	C 2.1-80 + CD 80E	C 2.1-80 + CD 80E
300	17	-	-	C 2.1-80 + CD 80E	C 2.1-80 + CD 80E
350	17	-	-	-	C 2.1-80 + CD 80E
400	15.6	-	-	-	-

Examples

Example EN 12828

Q = 200 kW
Flat radiators 70 | 50 °C
Hst = 15 m
psvs = 3,0 bar

Selected:

TecBox C 2.1-80 S
Extension vessel: not necessary

Check safety valve psvs:

for TAZ = 100 °C
EN 12828: psvs: $15/10 + 0,7 + 0,5 = 2,7 \leq 3,0$ o.k.

Example SWKI HE301-01

Q = 200 kW
Flat radiators 70 | 50 °C
Hst = 15 m
psvs = 3,0 bar

Selected:

TecBox C 2.1-80 S
Extension vessel: CD 80 E

Check safety valve psvs:

for TAZ = 100 °C
SWKI HE301-01: psvs: $(15/10 + 0,8) * 1,3 = 2,99 \leq 3,0$ o.k.

Equipment

Expansion pipes

According to table 5.

Lock shield valve DLV

Included with delivery.

Zeparo

Air vent Zeparo ZUT or ZUP at each high point for venting while filling and/or draining. Separator for dirt and magnetite in each system in the main return to the heat generator. If no central degassing (Vento V Connect) is installed a microbubble separator can be added in the main flow, before the circulation pump where possible.

The static height (Hst_m per the following table) above the microbubble separators must not be exceeded.

ts _{max} °C	90	80	70	60	50	40	30	20	10
Hst _m mWs	15,0	13,4	11,7	10,0	8,4	6,7	5,0	3,3	1,7

Application examples

Simply Compresso C 2.1-80 S

TecBox with one compressor and primary vessel, precision pressure maintenance $\pm 0,1$ bar.

For heating systems without water make-up

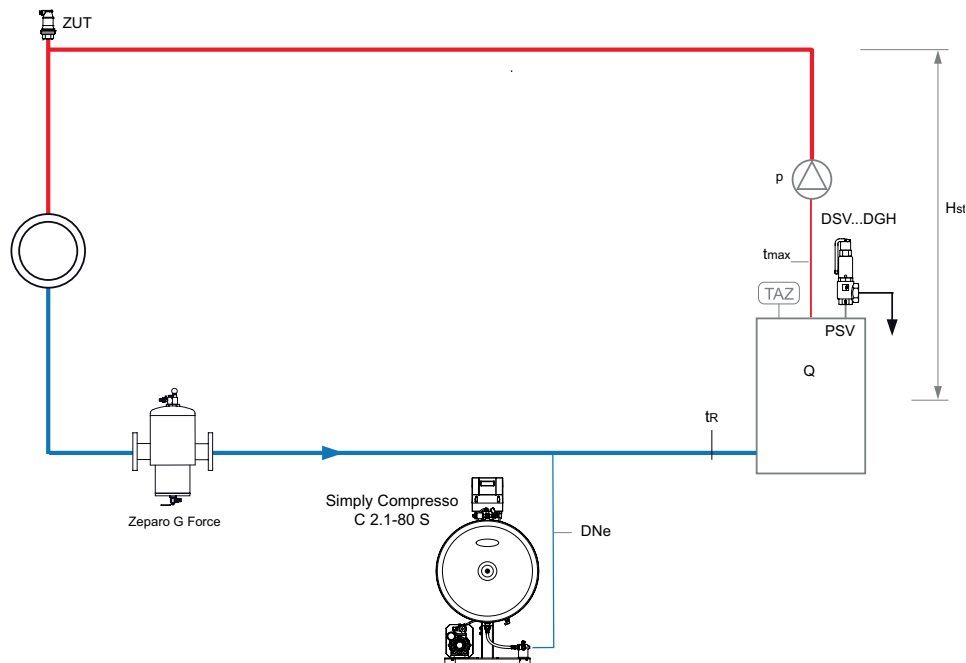

Simply Compresso C 2.1-80 SWM

TecBox with one compressor and primary vessel, precision pressure maintenance $\pm 0,1$ bar, Pleno P BA4R for water make-up and Pleno Refill for water treatment.

For heating systems with water make-up

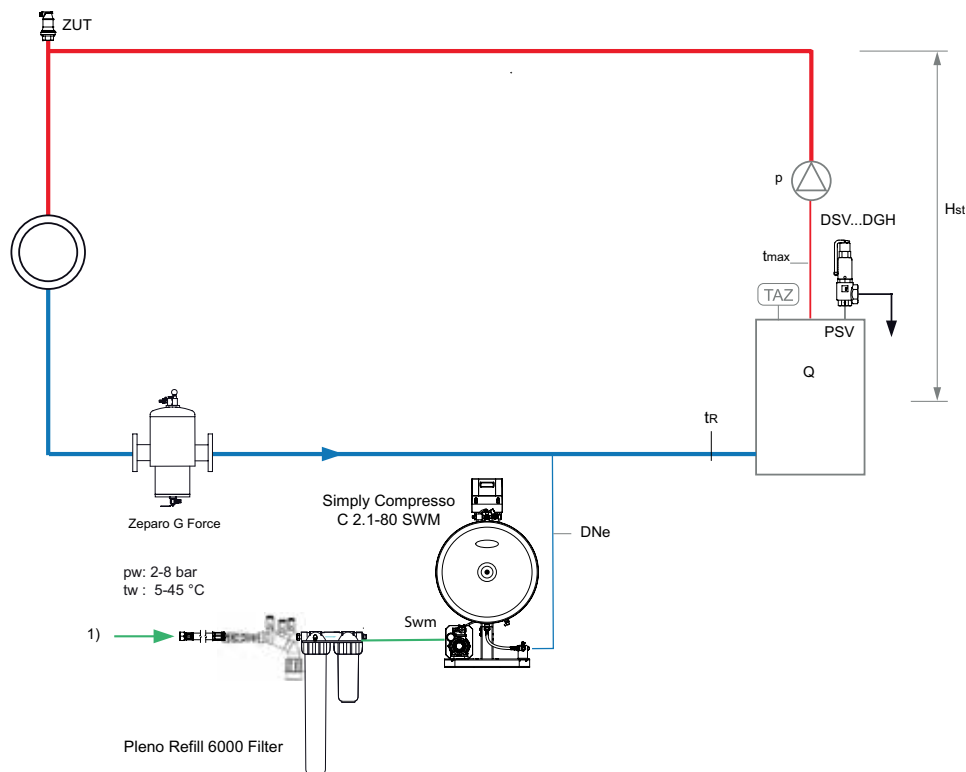

1) Water make-up connection, $p_w \geq p_0 + 1,7 \text{ bar}$ (max. 8 bar)

Zeparo G-Force cyclonic dirt separator with magnet ZGM in the return.

Zeparo ZUT for automatic venting while filling and/or draining.

Further accessories, product and selection details, see: Datasheet *Pleno*, *Zeparo* and *Accessories*.

Installation

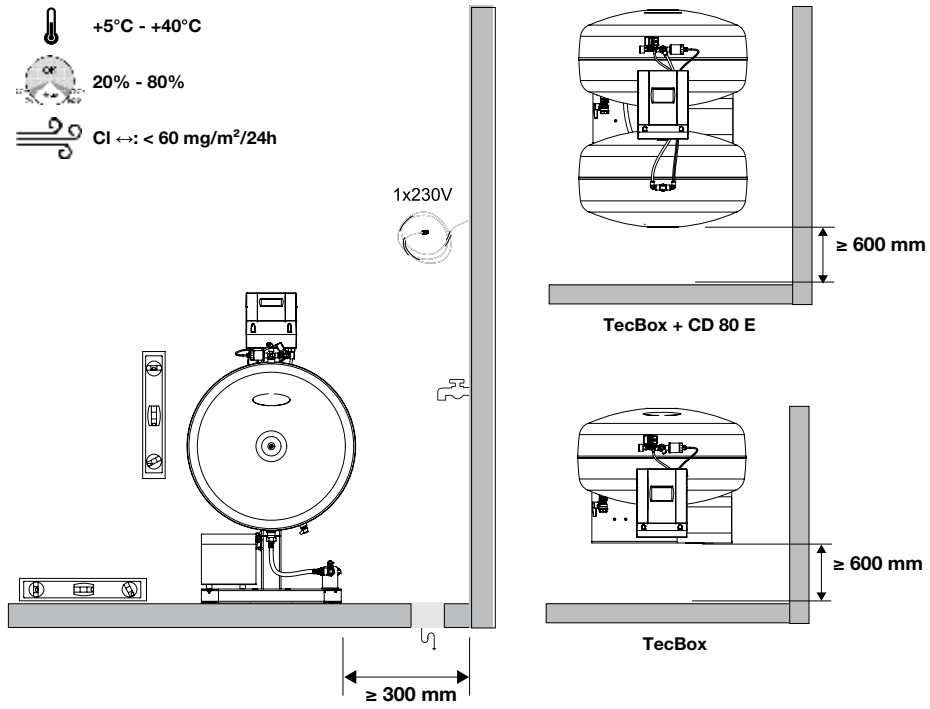

Compresso Connect F

Compresso is a precision pressurisation system with compressors for heating, solar and chilled water systems. It is especially suitable in situations where compactness and precision are required. The system capacity range lies between pressurisation with Statico and Transfero. The new **BrainCube Connect** control panel allows a new level of connectivity, enabling communication with the BMS system, other BrainCubes as well as remote operation of the pressurisation system through live viewing.

Key features

> Improved design for an easier and more comfortable operation

Resistant 3.5" TFT illuminated colour touch display. Intuitive and operation-friendly menu. Web based interface with remote control and live view. BrainCube Connect control panel integrated into TecBox.

> Remote Access and Troubleshooting

Remote access and commissioning support, reducing the need for high skilled staff to perform operations. Quicker response time, reduced repair costs. Data logging for system performance checks.

> State-of-the-Art Connectivity

Standardised connections to BMS and remote devices available (RS485, Ethernet, USB) enabling time savings during set-up and service and unit controllability. Communication with up to 8 BrainCubes in a Master/Slave network.



Technical description – Control unit TecBox

Applications:

Heating, solar and chilled water systems. For systems according to EN 12828, SWKI HE301-01, solar systems according to EN 12976, ENV 12977 with on-site excess temperature protection in case of power blackout.

Pressure:

Min. admissible pressure, PSmin: 0 bar
Max. admissible pressure, PS: see Articles

Temperature:

Max. admissible ambient temperature, TA: 40°C
Min. admissible ambient temperature, T Amin: 5°C

Accuracy:

Precision pressure maintenance $\pm 0,1$ bar.

Supply voltage:

1 x 230V (-6% + 10%), 50/60 Hz

Electric load:

See Articles.

Enclosure class:

IP 22 according to EN 60529

Sound pressure level:

59 dB(A) /1bar

Material:

Main materials include steel, brass and bronze.

Transportation and storing:

In frostless, dry places.

Standard:

Constructed according to LV-D. 2014/35/EU
EMC-D. 2014/30/EU

Compresso Connect

Compresso is a precision pressurisation system with compressors for heating, solar and chilled water systems. It is especially suitable in situations where compactness and precision are required. The system capacity range lies between pressurisation with Statico and Transfero. The new **BrainCube Connect** control panel allows a new level of connectivity, enabling communication with the BMS system, other BrainCubes as well as remote operation of the pressurisation system through live viewing.



Key features

> Improved design for an easier and more comfortable operation

Resistant 3.5" TFT illuminated colour touch display. Intuitive and operation-friendly menu. Web based interface with remote control and live view. BrainCube Connect control panel integrated into TecBox.

> State-of-the-Art Connectivity

Standardised connections to BMS and remote devices available (RS485, Ethernet, USB) enabling time savings during set-up and service and unit controllability. Communication with up to 8 BrainCubes in a Master/Slave network.

> Remote Access and Troubleshooting

Remote access and commissioning support, reducing the need for high skilled staff to perform operations. Quicker response time, reduced repair costs. Data logging for system performance checks.

Technical description – Control unit TecBox

Applications:

Heating, solar and chilled water systems. For systems according to EN 12828, SWKI HE301-01, solar systems according to EN 12976, ENV 12977 with on-site excess temperature protection in case of power blackout.

Pressure:

Min. admissible pressure, PSmin: 0 bar
Max. admissible pressure, PS: see Articles

Temperature:

Max. admissible ambient temperature, TA: 40°C
Min. admissible ambient temperature, TAmin: 5°C

Accuracy:

Precision pressure maintenance $\pm 0,1$ bar.

Supply voltage:

Compresso C10:
1 x 230 V (-6% + 10%), 50/60 Hz
Compresso C15:
1 x 230 V (-6% + 10%), 50 Hz

Electric load:

See Articles.

Enclosure class:

IP 22 according to EN 60529

Silent-run Compressors:

53-62 dB(A) / 1-10 bar

Material:

Main materials include steel, brass, and bronze.

Transportation and storing:

In frostless, dry places.

Standard:

Constructed according to
LV-D. 2014/35/EU
EMC-D. 2014/30/U

Quick selection

Heating systems TAZ ≤ 100°C, without addition of antifreeze, EN 12828.

Q [kW]	TecBox				Primary vessel			
	1 compressor	2 compressors	1 compressor	2 compressors	Radiators		Flat radiators	
	C 10.1	C 10.2	C 15.1	C 15.2	90 70	70 50	90 70	70 50
	Static height Hst **)				Nominal volume VN			
	[m]				[liter]			
≤ 300	47,1	47,1	82,4	82,4	200	200	200	200
400	47,1	47,1	82,4	82,4	300	300	200	200
500	47,1	47,1	82,4	82,4	300	300	200	200
600	46,0	47,1	81,2	82,4	400	400	300	300
700	42,0	47,1	72,8	82,4	500	500	300	300
800	38,5	47,1	66,0	82,4	500	500	400	300
900	35,6	47,1	60,4	82,4	600	600	400	400
1000	33,0	47,1	55,7	82,4	600	600	400	400
1100	30,8	46,7	51,6	82,4	800	800	500	400
1200	28,7	44,3	48,0	82,4	800	800	500	500
1300	26,9	42,1	44,8	82,4	800	800	500	500
1400	25,2	40,2	42,0	78,1	1000	1000	600	500
1500	23,7	38,4	39,5	74,1	1000	1000	600	600
2000	17,6	31,3	29,7	59,0	1500	1500	800	800
2500	13,1	26,3	23,0	48,9	1500	1500	1000	1000
3000	9,6	22,4	18,0	41,5	2000	2000	1500	1500
3500	-	19,3	14,1	35,7	3000	3000	1500	1500
4000	-	16,7	10,9	31,1	3000	3000	2000	1500
4500	-	14,5	8,2	27,3	3000	3000	2000	2000
5000	-	12,6	-	24,1	3000	3000	2000	2000
5500	-	10,9	-	21,3	4000	4000	3000	2000
6000	-	9,4	-	18,8	4000	4000	3000	3000
6500	-	8,0	-	16,7	4000	4000	3000	3000
7000	-	-	-	14,7	5000	5000	3000	3000
8000	-	-	-	11,4	5000	5000	4000	3000
9000	-	-	-	8,6			4000	4000
10000	-	-	-	6,3			4000	4000

**) With SWKI HE301-01 the value decreases with 1m

Example

Q = 700 kW
 Radiators 90 | 70 °C
 TAZ = 100 °C
 Hst = 35 m
 psvs = 6 bar

Selected:
 TecBox C 10.1-6
 Primary vessel CU 500.6

Setting of BrainCube:

Hst = 35 m
 TAZ = 100 °C

Check safety valve psvs:

for TAZ = 100 °C
 EN 12828: psvs: $(35/10 + 0,7) \cdot 1,11 = 4,66 < 6$ o.k.
 SWKI HE301-01: psvs: $(35/10 + 0,8) \cdot 1,15 = 4,95 < 6$ o.k.

Setting values

for TAZ, Hst and psv in the "Parameter" menu of the BrainCube.

			TAZ = 100 °C	TAZ = 105 °C	TAZ = 110 °C
EN 12828	Check psv:	for psv ≤ 5 bar	psv ≥ 0,1 · Hst + 1,2	psv ≥ 0,1 · Hst + 1,4	psv ≥ 0,1 · Hst + 1,6
		for psv > 5 bar	psv ≥ (0,1 · Hst + 0,7) · 1,11	psv ≥ (0,1 · Hst + 0,9) · 1,11	psv ≥ (0,1 · Hst + 1,1) · 1,11
SWKI HE301-01		for psv ≤ 3 bar	psv ≥ (0,1 · Hst + 0,8) · 1,3	psv ≥ (0,1 · Hst + 1,0) · 1,3	psv ≥ (0,1 · Hst + 1,2) · 1,3
		for psv > 3 bar	psv ≥ (0,1 · Hst + 0,8) · 1,15	psv ≥ (0,1 · Hst + 1,0) · 1,15	psv ≥ (0,1 · Hst + 1,2) · 1,15

Application examples

Compresso C 10.1 F Connect

TecBox with 1 compressor on the primary vessel, precision pressure maintenance $\pm 0,1$ bar with Pleno P water make-up

For heating systems up to approx. 2 000 kW

(May require changes to meet local legislation)

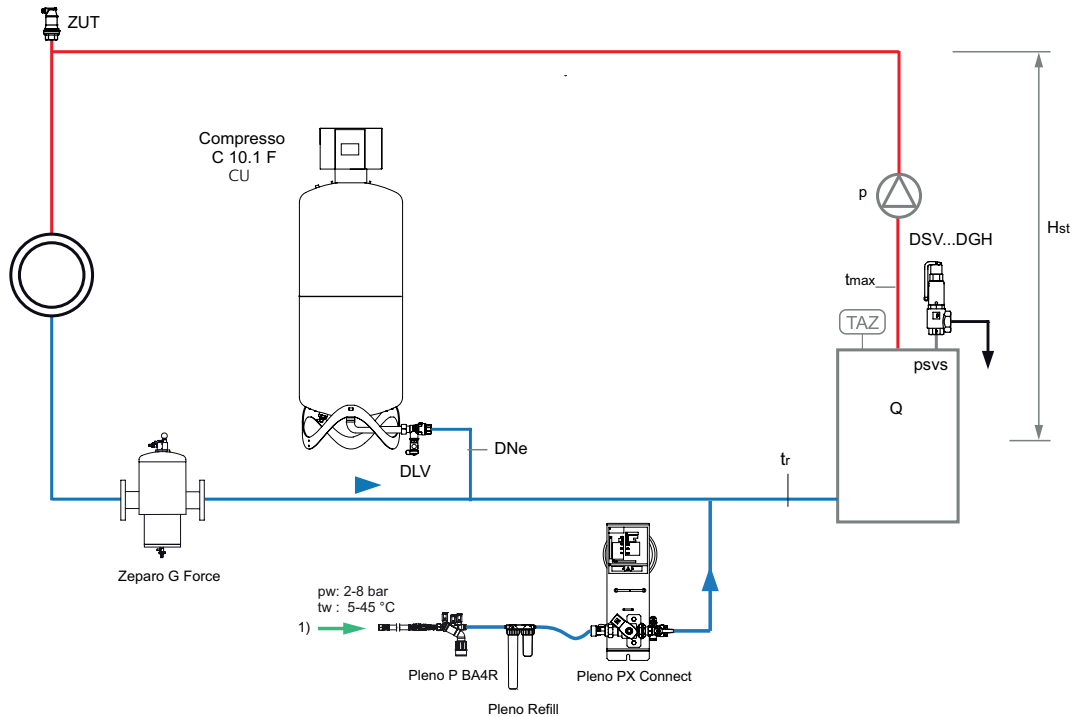

1) Water make-up connection, $p_w \geq p_0 + 1,7$ bar (max. 8 bar)

Compresso C 10.1 Connect

TecBox with 1 compressor ground standing beside the primary vessel, precision pressure maintenance $\pm 0,1$ bar with Pleno P water make-up

For heating systems up to approx. 6 500 kW

(May require changes to meet local legislation)

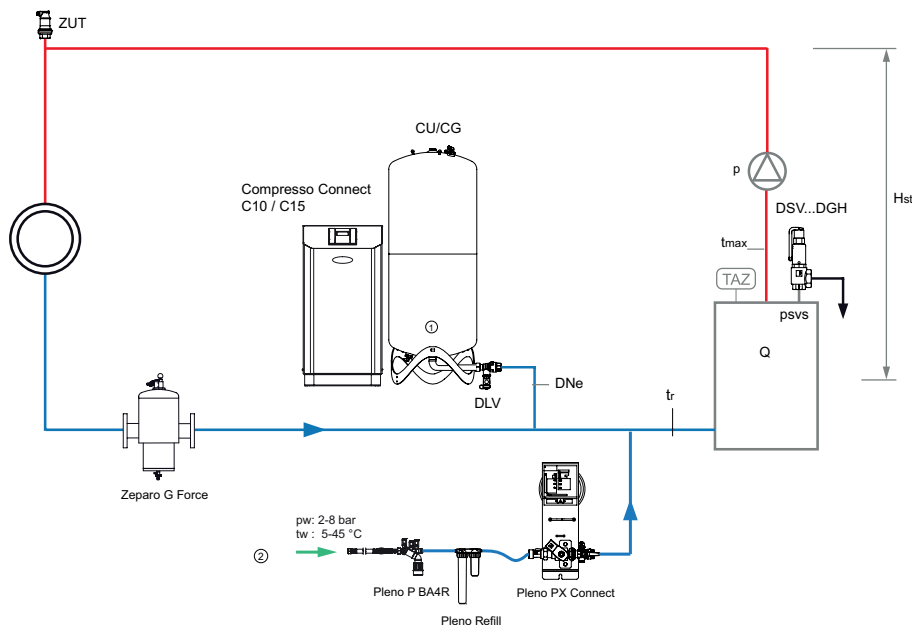



1. Compresso Primary vessel CU
2. Water make-up connection, $p_w \geq p_0 + 1,7$ bar (max. 10 bar)

Zeparo G Force cyclonic dirt separator with magnet ZIMA in the return.

Zeparo ZUT for automatic venting during filling and during draining.

Further accessories, product and selection details, see: Datasheet *Pleno*, *Zeparo* and *Accessories*.

Installation

-  +5°C - +40°C
-  20% - 80%
-  Cl ↔: < 60 mg/m²/24h

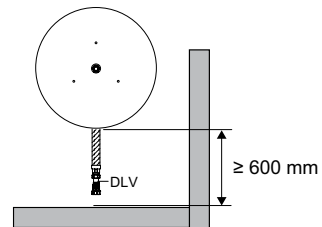
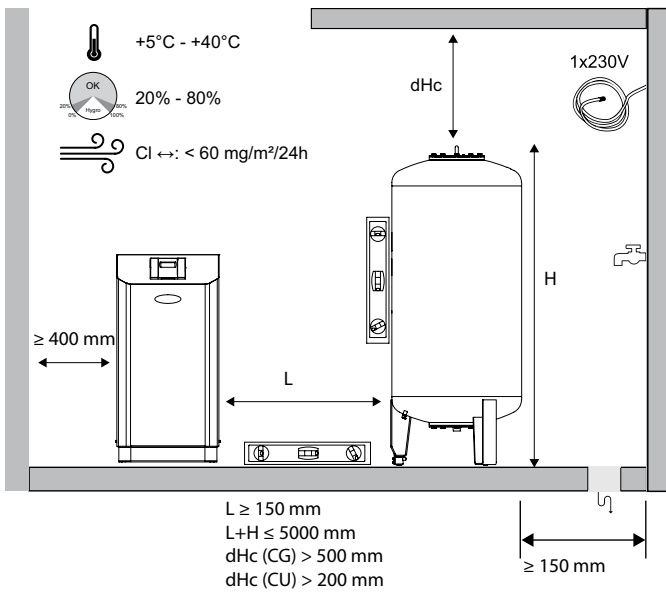
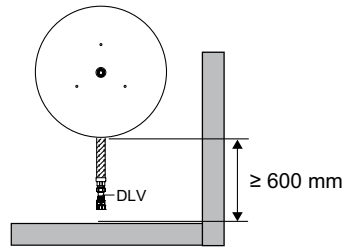
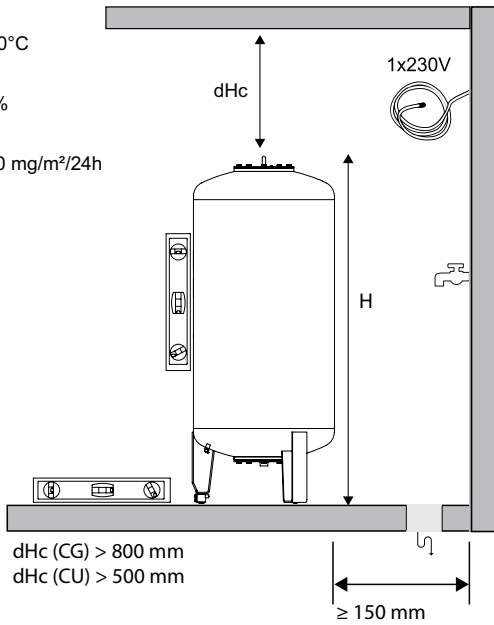

Transfero TV Connect

Transfero TV Connect is a precision pressure maintenance device for heating and solar systems up to 8 MW, and chilled water systems up to 13 MW. Its use is particularly recommended where high performance, compact design and precision are required. The new **BrainCube Connect** control panel allows a new level of connectivity, enabling communication with the BMS system, other BrainCubes as well as remote operation of the pressurisation system through live viewing.

Key features

- > **2 in 1**
The only pressurisation unit with integrated *cyclonic* vacuum degassing
- > **Higher Efficiency *Cyclonic* vacuum degassing**
At least 50% higher efficiency than most other vacuum degassing systems.
- > **Easy Commissioning, Remote Access and Trouble-shooting**
Automatic calibration and integrated standard connections to our IMI Webserver and to BMS.



Technical description – Control unit TecBox

Applications:

Heating, solar and chilled water systems. For systems according to EN 12828, SWKI HE301-01, solar systems according to EN 12976, ENV 12977 with on-site excess temperature protection in case of power outage.

Media:

Non-aggressive and non-toxic system media. Addition of antifreeze agent up to 50%.

Pressure:

Min. admissible pressure, PSmin: -1 bar
Max. admissible pressure, PS: see Articles

Temperature:

Max. admissible temperature, TS: 90°C
Min. admissible temperature, TSmin: 0°C
Max. admissible ambient temperature, TA: 40°C
Min. admissible ambient temperature, T Amin: 5°C

Accuracy:

Precision pressure maintenance $\pm 0,2$ bar.

Supply voltage:

1 x 230 V (-/+ 10 %), 50 Hz

Electrical connections:

1 plug socket (incl. counter plug) for supply voltage 230V (external fuses according power needs and local electrical norms)
4 potential free outputs (NO) for external alarm indication (230V max. 2A)
1 RS 485 In/Output
1 Ethernet RJ45 plug socket
1 USB Hub plug socket

Enclosure class:

IP54 according to EN 60529

Mechanical connections:

Sin1/Sin2: inlet from the system G3/4"
Sout: outlet to the system G3/4"
Swm: inlet water make-up G3/4"
Sv: connection of the vessel G1 1/4"

Material:

Metal components with medium contact: carbon steel, cast iron, stainless steel, AMETAL®, brass, gun metal.

Transportation and storage:

In frostless, dry places.

Standard:

Constructed according to LV-D. 2014/35/EU
EMC-D. 2014/30/EU

Quick selection

Heating systems TAZ ≤ 100°C, without addition of antifreeze, EN 12828, SWKI HE301-01.

For exact calculations please use HySelect software.

Q [kW]	TecBox					TecBox					TecBox					Primary vessel			
	1 pump					1 pump, high flow					2 pumps *, high flow					Radiators		Flat radiators	
	TV 4.1 E	TV 6.1 E	TV 8.1 E	TV 10.1 E	TV 14.1 E	TV 4.1 EH	TV 6.1 EH	TV 8.1 EH	TV 10.1 EH	TV 14.1 EH	TV 4.2 EH	TV 6.2 EH	TV 8.2 EH	TV 10.2 EH	TV 14.2 EH	90 70	70 50	90 70	70 50
Static height Hst [m] **	Static height Hst [m] **					Static height Hst [m] **					Static height Hst [m] **					Nominal volume VN [liter]			
min-max	min-max					min-max					min-max								
≤ 300	3-18	7-28	12-38	27-58	47-93	2-18	7-28	12-38	27-58	47-93	2-18	7-28	12-38	27-58	47-93	200	200	200	200
400	3-18	7-28	12-38	27-58	47-93	2-18	7-28	12-38	27-58	47-93	2-18	7-28	12-38	27-58	47-93	300	300	200	200
500	3-18	7-28	12-38	27-58	47-93	2-18	7-28	12-38	27-58	47-93	2-18	7-28	12-38	27-58	47-93	300	300	200	200
600	3-18	7-28	12-38	27-58	47-93	2-18	7-28	12-38	27-58	47-93	2-18	7-28	12-38	27-58	47-93	400	400	300	300
700	3-18	7-28	12-38	27-58	47-93	2-18	7-28	12-38	27-58	47-93	2-18	7-28	12-38	27-58	47-93	500	500	300	300
800	3-18	7-28	12-38	27-58	47-93	2-18	7-28	12-38	27-58	47-93	2-18	7-28	12-38	27-58	47-93	500	500	400	300
900	3-18	7-28	12-38	27-58	47-93	2-18	7-28	12-38	27-58	47-93	2-18	7-28	12-38	27-58	47-93	600	600	400	400
1000	3-18	7-28	12-38	27-58	47-93	2-18	7-28	12-38	27-58	47-93	2-18	7-28	12-38	27-58	47-93	600	600	400	400
1100	3-18	7-28	12-38	27-58	47-93	2-18	7-28	12-38	27-58	47-93	2-18	7-28	12-38	27-58	47-93	800	800	500	500
1200	5-18	7-28	12-38	27-58	47-93	2-18	7-28	12-38	27-58	47-93	2-18	7-28	12-38	27-58	47-93	800	800	500	500
1300	7-18	7-28	12-38	27-58	47-93	2-18	7-28	12-38	27-58	47-93	2-18	7-28	12-38	27-58	47-93	800	800	500	500
1400	10-18	10-28	12-38	27-58	47-93	2-18	7-28	12-38	27-58	47-93	2-18	7-28	12-38	27-58	47-93	1000	1000	600	600
1500	12-18	12-28	12-38	27-58	47-93	2-18	7-28	12-38	27-58	47-93	2-18	7-28	12-38	27-58	47-93	1000	1000	600	600
1600	15-18	15-28	15-38	27-58	47-93	2-18	7-28	12-38	27-58	47-93	2-18	7-28	12-38	27-58	47-93	1000	1000	800	800
1700		18-28	18-38	27-58	47-93	2-18	7-28	12-38	27-58	47-93	2-18	7-28	12-38	27-58	47-93	1500	1500	800	800
1800		21-28	21-38			2-18	7-28	12-38	27-58	47-93	2-18	7-28	12-38	27-58	47-93	1500	1500	800	800
1900		24-28	24-38			2-18	7-28	12-38	27-58	47-93	2-18	7-28	12-38	27-58	47-93	1500	1500	800	800
2000			28-38			2-18	7-28	12-38	27-58	47-93	2-18	7-28	12-38	27-58	47-93	1500	1500	800	800
2100			32-38			2-18	7-28	12-38	27-58	47-93	2-18	7-28	12-38	27-58	47-93	1500	1500	1000	1000
2200			35-38			2-18	7-28	12-38	27-58	47-93	2-18	7-28	12-38	27-58	47-93	1500	1500	1000	1000
2500						2-18	7-28	12-38	27-58	47-93	2-18	7-28	12-38	27-58	47-93	1500	1500	1000	1000
3000						2-18	7-28	12-38	27-58	47-82	2-18	7-28	12-38	27-58	47-93	2000	2000	1500	1500
3500						2-15	7-26	12-35	27-52	47-62	2-18	7-28	12-38	27-58	47-93	3000	3000	1500	1500
4000						2-10	7-21	12-29	27-46		2-18	7-28	12-38	27-58	47-93	3000	3000	2000	2000
4500						2-4	7-14	12-21	27-37		2-18	7-28	12-38	27-58	47-93	3000	3000	2000	2000
5000								12-14	27-28		2-18	7-28	12-38	27-58	47-92	3000	3000	2000	2000
5500											2-15	7-27	12-36	27-55	47-83	4000	4000	3000	3000
6000											3-11	7-23	12-32	27-50	47-73	4000	4000	3000	3000
6500											4-7	7-19	12-28	27-45	47-61	4000	4000	3000	3000
7000												8-15	12-23	27-40	47-48	5000	5000	3000	3000
7500												8-10	12-18	27-34		5000	5000	3000	3000
8000														27-28		5000	5000	4000	4000

*) 50% output per pump, full redundancy in the framed area.

**) The value decreases with

TAZ = 105 °C by 2 m TAZ = 110 °C by 4 m

SWKI HE301-01 by another 1m

Check psv:

for TAZ = 105 °C

EN 12828 psv: $(35/10 + 0,9 + 0,2) \cdot 1,11 = 5,11 \leq 6,5$ o.k.

SWKI HE301-01 psv: $(35/10 + 1,0 + 0,2) \cdot 1,15 = 5,41 \leq 6,5$ o.k.

Check Hst:

for TAZ = 105 °C

Hst: $38 - 2 = 36 \geq 35$

Transfero

= TecBox + Primary vessel + Extension vessel (optional)

Extension vessel

The nominal volume can be allocated to multiple vessels of the same size.

Example

Q = 1300 kW

Flat radiators 90 | 70 °C

TAZ = 105 °C

Hst = 35 m

psv = 6,5 bar

Selected:

TecBox TV 8.1 E

Primary vessel TU 500

Setting of BrainCube:

Hst = 35 m

TAZ = 105 °C

Application examples

Transfero TV .1 E Connect

TecBox with 1 pump, precision pressure maintenance $\pm 0,2$ bar with cyclonic vacuum degassing, Pleno P BA4R for water make-up.

Example for heating systems, return temperature $tr \leq 70^\circ\text{C}$

(May require changes to meet local legislation)

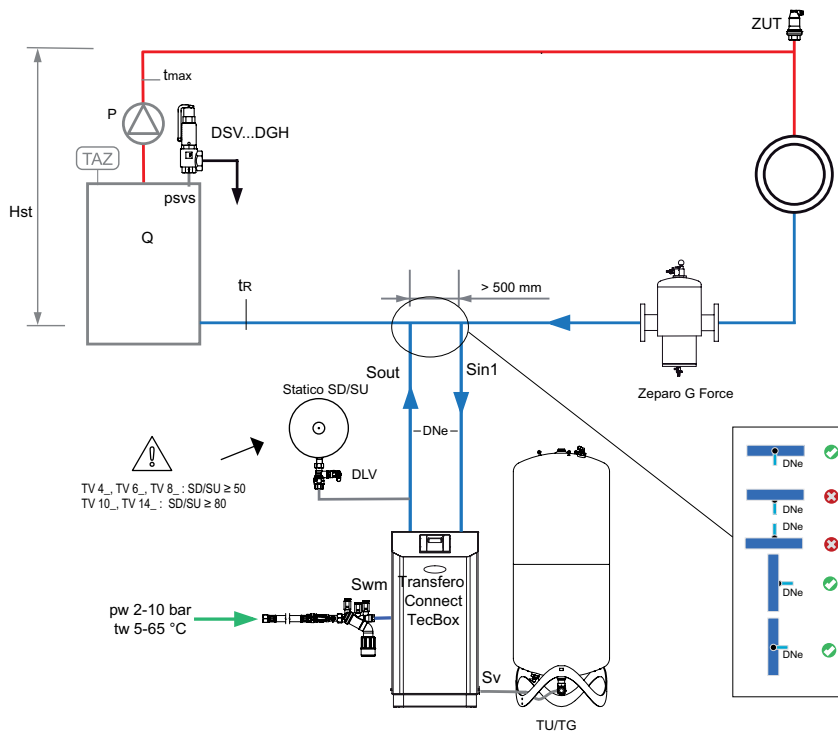

Transfero TV .2 EHC Connect

TecBox with 2 pumps, precision pressure maintenance $\pm 0,2$ bar with cyclonic vacuum degassing. Pleno P AB5 for water make-up.

Example for cooling systems, return temperature $0^\circ\text{C} < tr \leq 5^\circ\text{C}$

(May require changes to meet local legislation)

Scheme is also valid for Transfero TV .1EHC

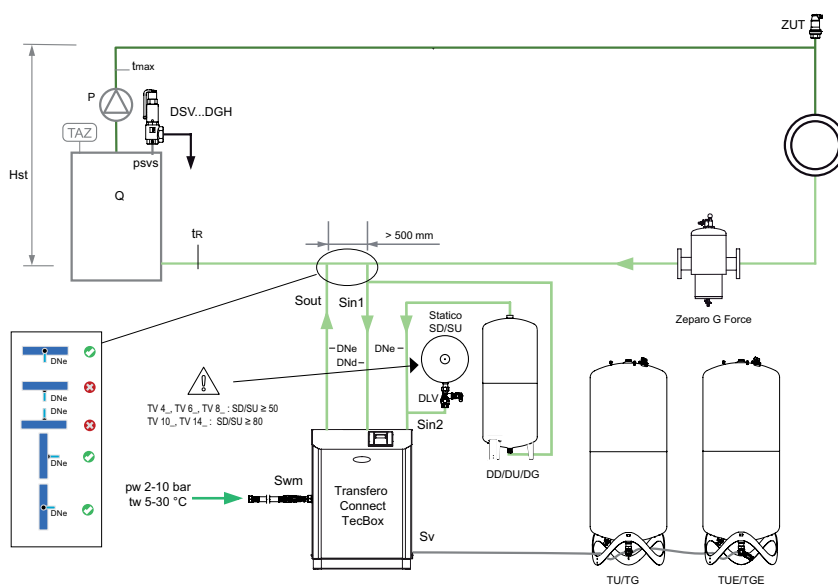

Zeparo G-Force for the central separation of sludge.

Zeparo ZUT for automatic venting during filling and during draining.

Further accessories, product and selection details, see: Datasheet *Pleno Connect*, *Zeparo* and *Accessories*.

Example for heating systems, return temperature $tr \leq 70^\circ\text{C}$

(May require changes to meet local legislation)

Scheme is also valid for *Transfero TV .1EH*

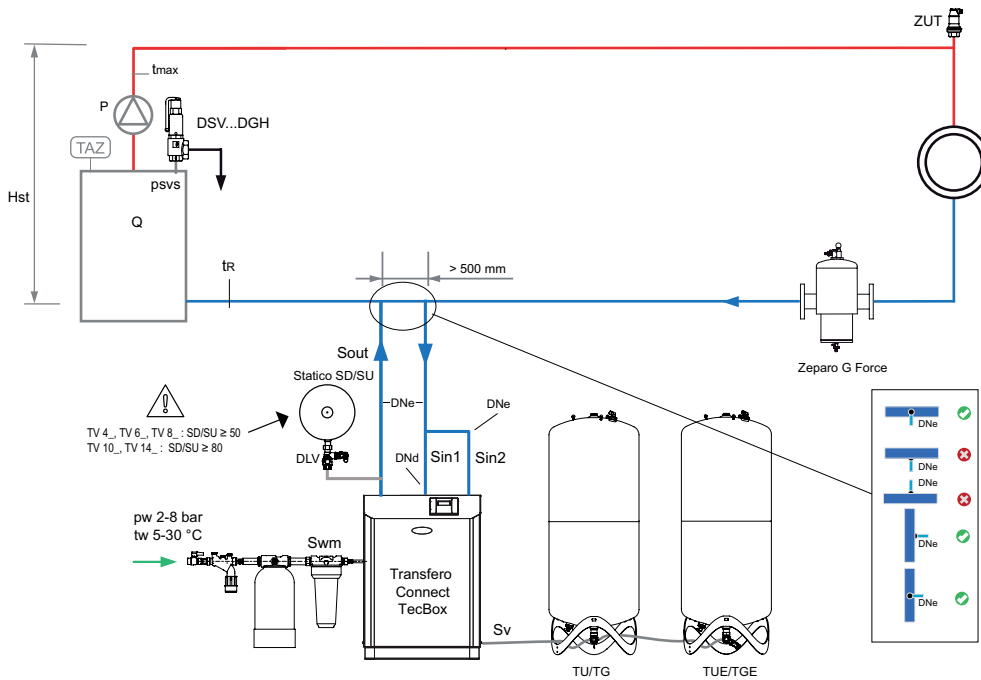

Transfero TV .2 EH Connect

TecBox with 2 pumps, precision pressure maintenance $\pm 0,2$ bar with cyclonic vacuum degassing, Pleno P AB5 R for the water make-up and Pleno Refill for water treatment.

Example for heating systems, return temperature $70^\circ\text{C} < tr \leq 90^\circ\text{C}$

(May require changes to meet local legislation)

Scheme is also valid for *Transfero TV .1EH*

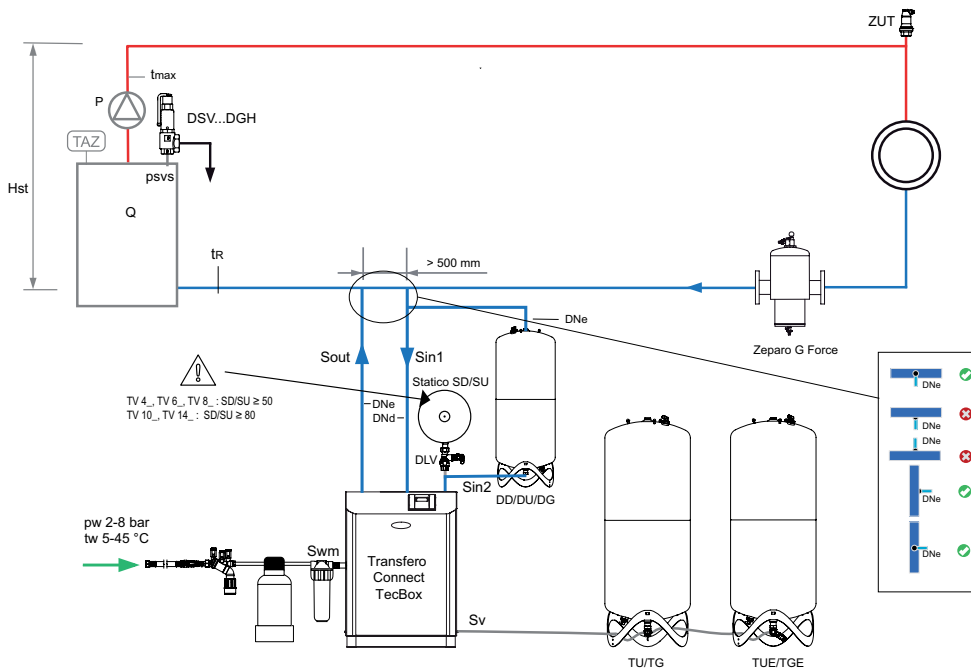

Zeparo G-Force for the central separation of sludge.

Zeparo ZUT for automatic venting during filling and during draining.

Further accessories, product and selection details, see: Datasheet *Pleno Connect*, *Zeparo* and *Accessories*.

Transfero TVI Connect

The Transfero TVI Connect is a precision pressure maintenance device for higher pressures in heating and solar systems up to 8 MW, and chilled water systems up to 13 MW. Its use is particularly recommended where high performance, compact design and precision are required. The new **BrainCube Connect** control panel allows a new level of connectivity, enabling communication with the BMS system and other BrainCubes, as well as remote operation of the pressurisation system through live viewing.

Key features

- > **2 in 1**
The only pressurisation unit with integrated *cyclonic* vacuum degassing
- > **Higher Efficiency Cyclonic vacuum degassing**
At least 50% higher efficiency than most other vacuum degassing systems.
- > **Easy Commissioning, Remote Access and Trouble-shooting**
Automatic calibration and integrated standard connections to our IMI Webserver and to BMS.



Technical description – Control unit TecBox

Applications:

Heating, solar and chilled water systems. For systems according to EN 12828, SWKI HE301-01, solar systems according to EN 12976, ENV 12977 with on-site excess temperature protection in case of power outage.

Media:

Non-aggressive and non-toxic system media.
Addition of antifreeze agent up to 50%.

Pressure:

Min. admissible pressure, PSmin: -1 bar
Max. admissible pressure, PS: see Articles

Temperature:

Max. admissible temperature, TS: 90°C
Min. admissible temperature, TSmin: 0°C
Max. admissible ambient temperature, TA: 40°C
Min. admissible ambient temperature, Tamin: 5°C

Accuracy:

Precision pressure maintenance $\pm 0,2$ bar.

Supply voltage:

Main voltage: 3x400V ($\pm 10\%$) / 50Hz (3P+PE)
Control voltage: 230V ($\pm 10\%$) / 50Hz (P+N+PE)

Electrical connections:

Onsite fuses according to power demand and local norms
4 potential free outputs (NO) for external alarm indication (230V max. 2A)
1 RS 485 In/Output
1 Ethernet RJ45 plug socket
1 USB Hub plug socket
Terminal strip in PowerCube for direct wiring

Enclosure class:

IP54 according to EN 60529

Mechanical connections:

Sin1/Sin2: inlet from the system G3/4"
Sout: outlet to the system G3/4"
Swm: inlet water make-up G3/4"
Sv: connection of the vessel G1 1/4"

Material:

Metal components with medium contact: carbon steel, cast iron, stainless steel, AMETAL®, brass, gun metal.

Transportation and storage:

In frostless, dry places.

Standard:

Constructed according to LV-D. 2014/35/EU
EMC-D. 2014/30/EU

Quick selection

Heating systems TAZ ≤ 100°C, without addition of antifreeze, EN 12828, SWKI HE301-01.

For exact calculations please use HySelect software.

Q [kW]	TecBox				Primary vessel			
	1 pump, high flow		2 pumps *, high flow		Radiators		Flat radiators	
	TVI 19.1 EH	TVI 25.1 EH	TVI 19.2 EH	TVI 25.5 EH	90 70	70 50	90 70	70 50
	Static height Hst [m] **		Static height Hst [m] **		Nominal volume VN [liter]			
	min-max		min-max					
≤ 300	58-149	98-199	58-149	98-199	200	200	200	200
400	58-149	98-199	58-149	98-199	300	300	200	200
500	58-149	98-199	58-149	98-199	300	300	200	200
600	58-149	98-199	58-149	98-199	400	400	300	300
700	58-149	98-199	58-149	98-199	500	500	300	300
800	58-149	98-199	58-149	98-199	500	500	400	300
900	58-149	98-199	58-149	98-199	600	600	400	400
1000	58-149	98-199	58-149	98-199	600	600	400	400
1100	58-149	98-199	58-149	98-199	800	800	500	500
1200	58-149	98-199	58-149	98-199	800	800	500	500
1300	58-149	98-199	58-149	98-199	800	800	500	500
1400	58-149	98-199	58-149	98-199	1000	1000	600	600
1500	58-149	98-199	58-149	98-199	1000	1000	600	600
1600	58-149	98-199	58-149	98-199	1000	1000	800	800
1700	58-149	98-199	58-149	98-199	1500	1500	800	800
1800	58-149	98-199	58-149	98-199	1500	1500	800	800
1900	58-149	98-199	58-149	98-199	1500	1500	800	800
2000	58-149	98-199	58-149	98-199	1500	1500	800	800
2100	58-149	98-199	58-149	98-199	1500	1500	1000	1000
2200	58-149	98-199	58-149	98-199	1500	1500	1000	1000
2500	58-147	98-199	58-149	98-199	1500	1500	1000	1000
3000	58-132	98-186	58-149	98-199	2000	2000	1500	1500
3500	58-115	98-166	58-149	98-199	3000	3000	1500	1500
4000	58-94	98-143	58-149	98-199	3000	3000	2000	2000
4500	58-70	98-117	58-149	98-199	3000	3000	2000	2000
5000			58-144	98-199	3000	3000	2000	2000
5500			58-137	98-192	4000	4000	3000	3000
6000			58-128	98-183	4000	4000	3000	3000
6500			58-119	98-173	4000	4000	3000	3000
7000			58-109	98-162	5000	5000	3000	3000
7500			58-98	98-149	5000	5000	3000	3000
8000			58-86	98-136	5000	5000	4000	4000

*) 50% output per pump, full redundancy in the framed area.

**) The value decreases with

TAZ = 105 °C by 2 m

TAZ = 110 °C by 4 m

SWKI HE301-01 by another 1m

Example

Q = 3300 kW

Flat radiators 90 | 70 °C

TAZ = 105 °C

Hst = 110 m

psv = 16 bar

Selected:

TecBox TVI 19.1 EH

Primary vessel TG 1500

Setting of BrainCube:

Hst = 110 m

TAZ = 105 °C

26

Check psv:

for TAZ = 105 °C

EN 12828 psv: $(110/10 + 0,9 + 0,2) \cdot 1,11 = 12,32 \leq 16$ o.k.

SWKI HE301-01 psv: $(110/10 + 1,0 + 0,2) \cdot 1,15 = 12,88 \leq 16$ o.k.

Check Hst:

for TAZ = 105 °C

Hst: $115 - 2 = 113 \geq 110$

Transfero

= TecBox + Primary vessel + Extension vessel (optional)

Extension vessel

The nominal volume can be allocated to multiple vessels of the same size.

Application examples

Transfero TVI.1 EH Connect

TecBox with 1 pump, precision pressure maintenance $\pm 0,2$ bar with cyclonic vacuum degassing, Pleno P BA4R for water make-up.

Example for heating systems, return temperature $tr \leq 70^\circ\text{C}$

(May require changes to meet local legislation)

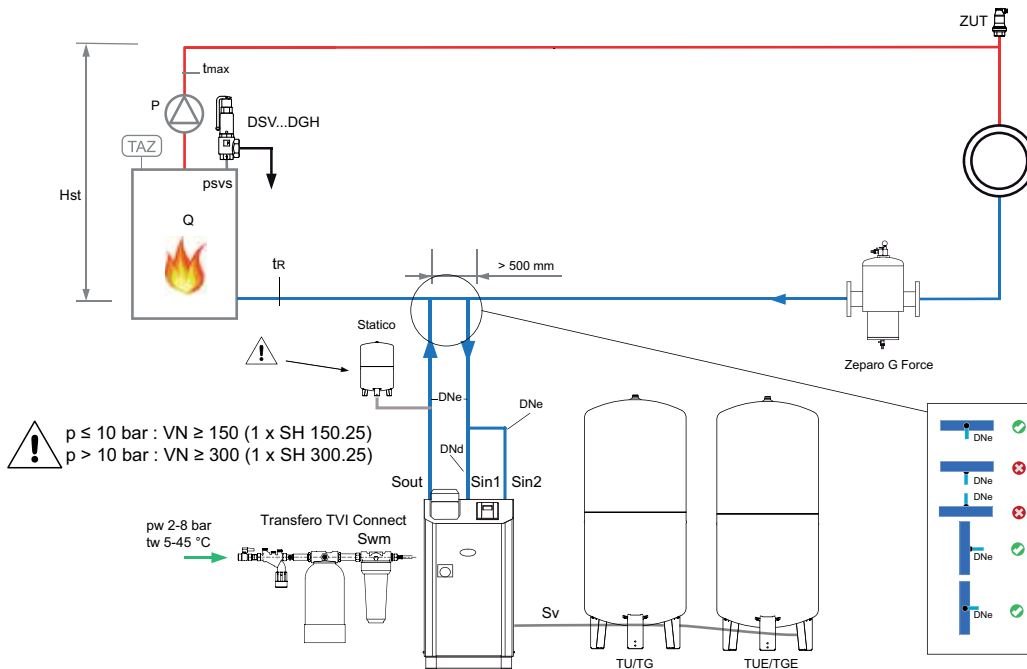

Transfero TVI.2 EHC Connect

TecBox with 2 pumps, precision pressure maintenance $\pm 0,2$ bar with cyclonic vacuum degassing. Pleno P AB5 for water make-up.

Example for cooling systems, return temperature $0^\circ\text{C} < tr \leq 5^\circ\text{C}$

(May require changes to meet local legislation)

Scheme is also valid for Transfero TVI.1 EHC

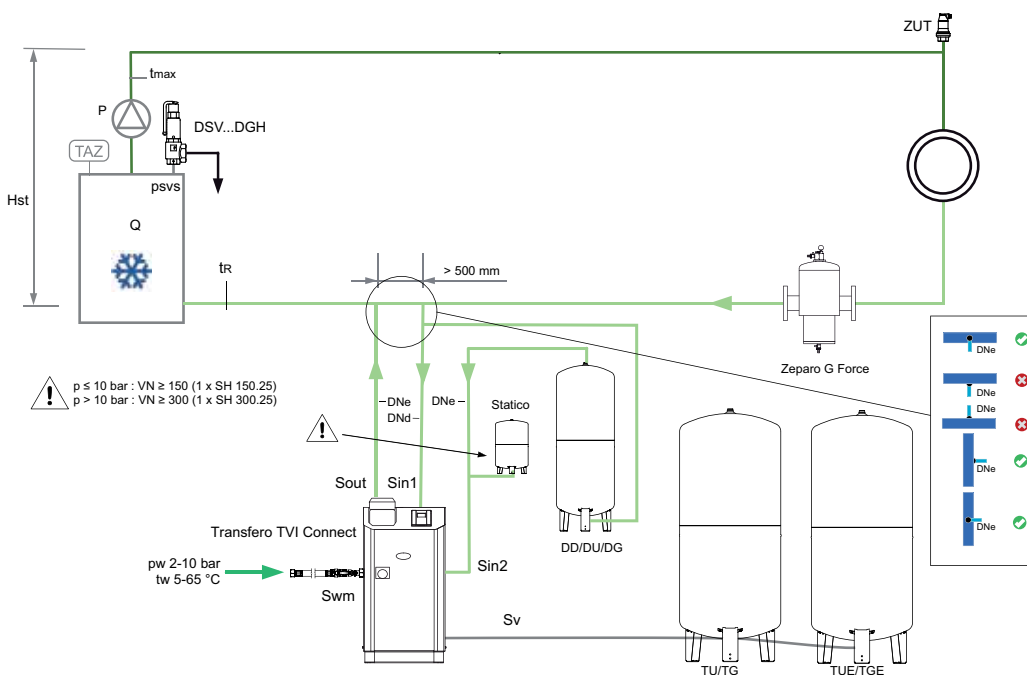

Zeparo G-Force for the central separation of sludge.

Zeparo ZUT for automatic venting during filling and during draining.

Further accessories, product and selection details, see: Datasheet *Pleno Connect*, *Zeparo* and *Accessories*.

Transfero TVI.2 EH Connect

TecBox with 2 pumps, precision pressure maintenance $\pm 0,2$ bar with cyclonic vacuum degassing, Pleno P AB5 R for the water make-up and Pleno Refill for water treatment.

Example for heating systems, return temperature $tr \leq 70^\circ\text{C}$

(May require changes to meet local legislation)

Scheme is also valid for Transfero TVI.1 EH

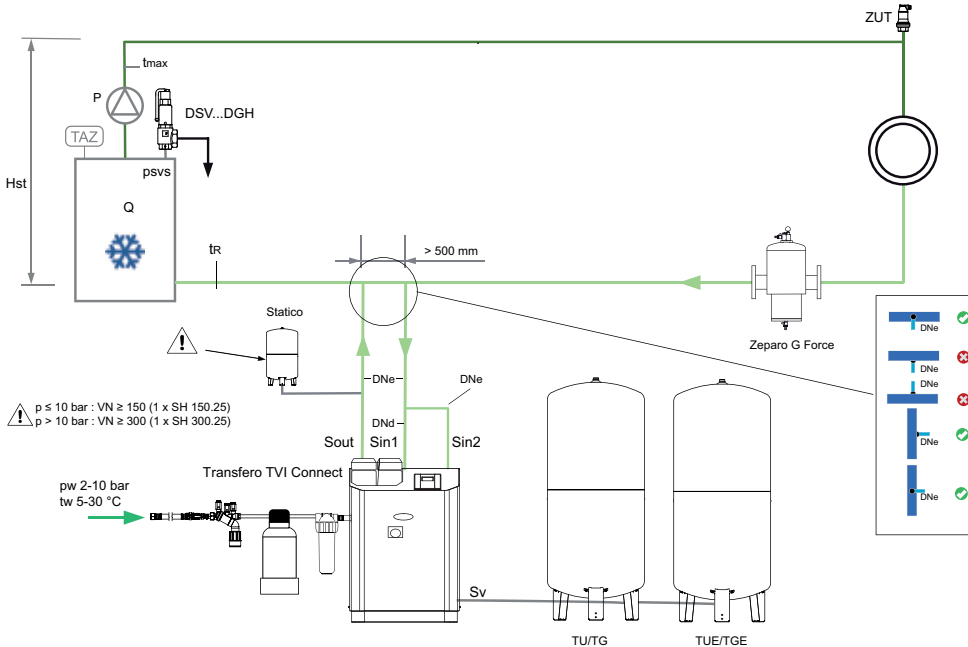

Transfero TVI.2 EH Connect

TecBox with 2 pumps, precision pressure maintenance $\pm 0,2$ bar with cyclonic vacuum degassing, Pleno P AB5 R for the water make-up and Pleno Refill for water treatment.

Example for heating systems, return temperature $70^\circ\text{C} < tr \leq 90^\circ\text{C}$

(May require changes to meet local legislation)

Scheme is also valid for Transfero TVI.1 EH

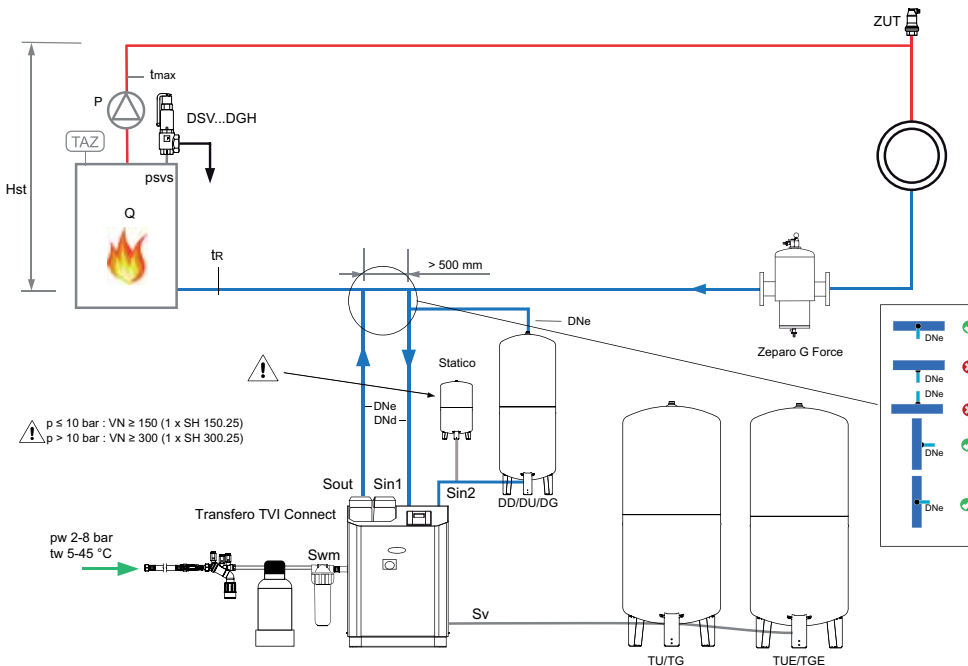

Zeparo G-Force for the central separation of sludge.

Zeparo ZUT for automatic venting during filling and during draining.

Further accessories, product and selection details, see: Datasheet Pleno Connect, Zeparo and Accessories.

Aquapresso

Expansion vessels with fixed gas cushion for drinking water systems. The airtight bag, made from a special butyl rubber compound suitable for drinking water, is legendary. In addition to full flow-through, the vessels offer a unique standard of hygiene.



Key features

- > **Airtight butyl bag according to EN 13831**
- > **Wide range of vessel sizes for different system needs**
From 8 L to 3000 L
- > **Brilliantly simple, robust design**
Operation without auxiliary power.
- > **Excellent elasticity**
Thanks to the fixed gas cushion.

Technical description

Application:

Potable water heating and pressure-boosting systems, with a maximum chloride content of 125 mg/l (70 °C) / 250 mg/l (45 °C).

Pressure:

Min. admissible pressure, PSmin: 0 bar
Max. admissible pressure, PS: see Articles
Default pressure maintenance (p0): 4 bar

Temperature:

Max admissible temperature, TS: 120 °C
Min admissible temperature, TSmin: -10 °C
Max admissible bag temperature, TB: 70 °C
Min admissible bag temperature, TBmin: 5 °C

Material:

Steel. Colour beryllium.
All metallic parts in contact with water in stainless steel.

Transportation and storage:

In frostless, dry places.

Standards:

Constructed according to PED 2014/68/EU.
Local drinking water legislations apply.

Function, Equipment, Features

- Airtight butyl bag according to EN 13831 and IMI Pneumatex internal standards. Exchangeable on AG, AGF models.
- Hydrowatch for bag tightness control (ADF, AUF, AGF).
- Flowfresh full flow-through (ADF, AUF, AGF).
- Endoscopic inspection hole (AU, AUF), two flanged openings (AG, AGF) for internal inspections.
- Feet for upright assembly (AG, AGF, AU, AUF). Wall bracket for easy assembly (AD, ADF).



green = OK
red = bag damage

Aquapresso in potable hot water systems

By temporarily storing expansion water that would otherwise be lost through the safety valve, the Aquapresso contributes to reduced water usage in potable hot water systems. Correct pressure presets are key for a faultless and reliable operation.

Approvals

Aquapresso is designed for potable water systems. Since there are no uniform standards, always observe local regulations regarding selection, based on which either full or no flow-through models may be deployed.

Calculation

Preset pressure

$$p_0 = p_a - 0,3 \text{ bar}$$

The preset pressure of the Aquapresso is set to at least 0,3 bar below the initial pressure p_a .

Initial pressure

$$p_a = p_{FL}$$

The initial pressure corresponds to the flow pressure p_{FL} . It should be kept at a constant level by means of the installation of a pressure regulating valve in the cold water line.

Safety valve

The non-operative pressure p_R in the potable water network must not exceed 80% of the safety valve response pressure.

$$p_{sv} = \frac{p_R}{0,8}$$

Nominal volume

V_{hs} is the nominal volume of the potable water heater. e (60 °C, table 1)

$$VN = V_{hs} \cdot e \cdot \frac{(p_{sv} + 0,5) \cdot (p_0 + 1,3)}{(p_0 + 1) \cdot (p_{sv} - p_0 - 0,8)}$$

Table 1: e expansion coefficient

t (TAZ, $t_{s_{max}}$, t_r , $t_{s_{min}}$), °C	20	30	40	50	60	70	80	90	100	105	110
e Water = 0 °C	0,0016	0,0041	0,0077	0,0119	0,0169	0,0226	0,0288	0,0357	0,0433	0,0472	0,0513

Quick selection

Heating-up from 10°C to 60°C

psv [bar]	p0 4,0 bar pa 4,3 bar				p0 3,0 bar pa 3,3 bar			
	6	7	8	10	6	7	8	10
Vhs [liter]	Nominal volume VN [liter]							
50	8	8	8	8	8	8	8	8
80	8	8	8	8	8	8	8	8
100	12	8	8	8	8	8	8	8
150	18	12	8	8	8	8	8	8
180	18	12	12	8	8	8	8	8
200	25	12	12	8	12	8	8	8
250	25	18	12	12	12	12	8	8
300	35	18	18	12	18	12	12	12
400	50	25	25	18	18	18	12	18
500	50	35	25	25	25	18	18	25
600	80	50	35	25	35	25	18	25
700	80	50	35	35	35	25	25	25
800	80	50	50	35	35	35	25	25
900	140	80	50	35	50	35	35	35
1000	140	80	50	50	50	35	35	35

Example

$V_{hs} = 200$ litre
 $p_a = 3,3$ bar
 $p_{sv} = 10$ bar

Selected:

Aquapresso ADF 8.10 with full flow-through
 $p_0 = 3$ bar
 Reduce the default pressure preset from 4 bar to 3 bar.

Aquapresso in pressure-boosting systems

In pressure-boosting systems the Aquapresso can stabilise the potable water network and reduce the switching frequency. May be installed at either the low or high pressure sides of the system. Installation of an Aquapresso on the mains is always to be coordinated with local water utilities.

Aquapresso A...F with bypass

For the flow-through Aquapresso models A...F, if the maximum flow q_{max} exceeds the nominal flow q_N the device must be installed with a bypass. The bypass is to be dimensioned for the flow difference with a flow speed of 2 m/s. See Application example or instruction.

Calculation

Aquapresso on the suction side

Calculation according to 1988 T5

q_{max} m ³ /h	VN litre	qN Nominal flow
≤ 7	≥ 300	according to Datasheet
< 7 ≤ 15	≥ 500	
> 15	≥ 800	

Aquapresso for water hammering absorption

This topic is very complex and complicated. We recommend to have the calculation done by a specialized engineering office.

Aquapresso on the discharge side

VN calculation according to DIN 1988 T5 for the restriction of the switching frequency

$$VN = 0,33 \cdot q_{max} \cdot \frac{pa + 1}{(pa - pe) \cdot s \cdot n}$$

s Switching frequency | 1/h

Pump capacity | kW

20	≤ 4,0
15	≤ 7,5
10	> 7,5

VN calculation by storage volume V between working pressure and turn-off pressure

$$VN = q \cdot \frac{(pe + 1) \cdot (pa + 1)}{(p0 + 1) \cdot (pa - pe)}$$

n = Number of pumps

pe = Working pressure

pa = Turn-off pressure

q_{max} = flow pump

Diagrams

Ca. Pressure loss Δp – Aquapresso ADF

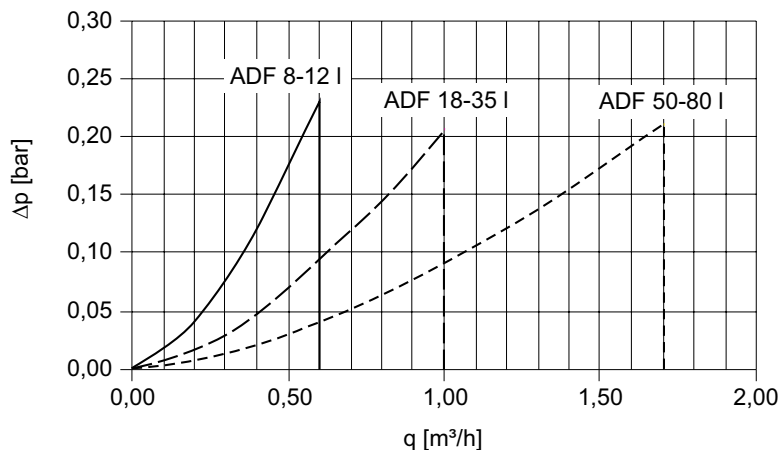

Ca. Pressure loss Δp – Aquapresso AUF, AGF

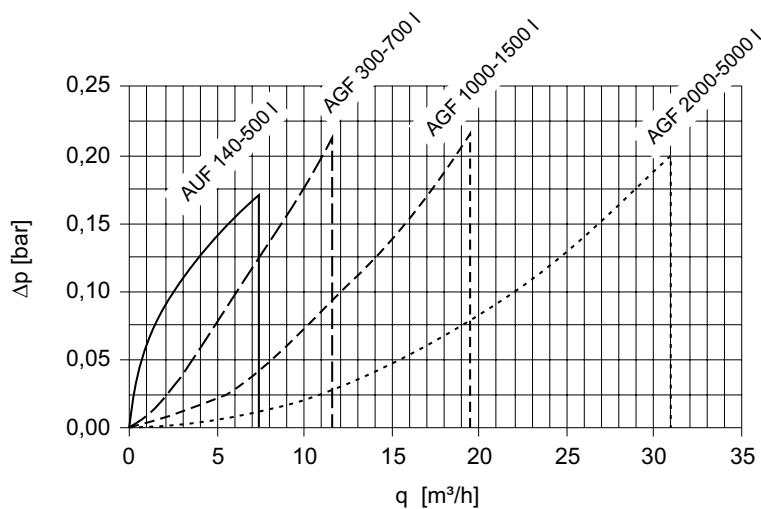

Application examples

Aquapresso ADF

with flowfresh full flow-through in a potable water heating system
(May require changes to meet local legislation)

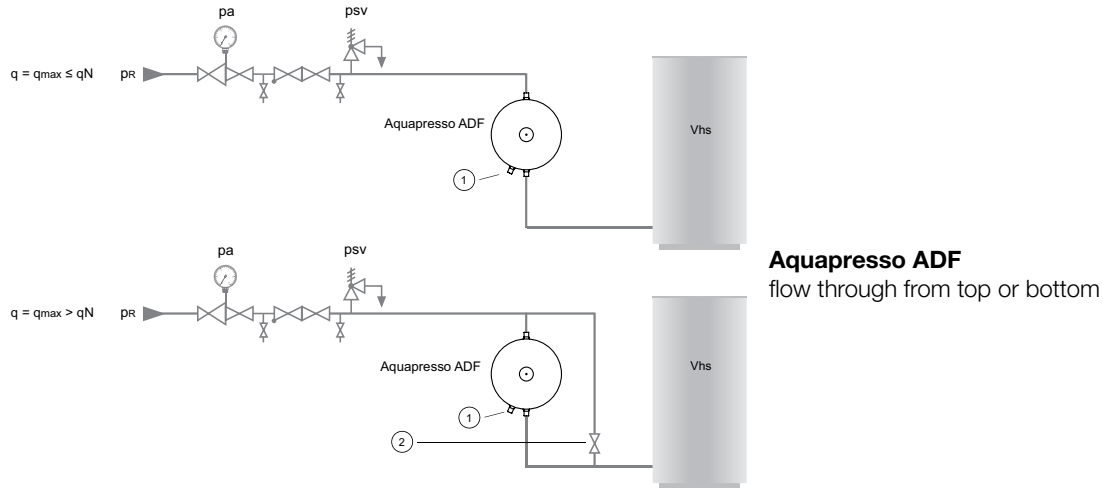

1. Hydrowatch
2. Bypass open, remove handwheel

Aquapresso AUF/AU

in a pressure-boosting system
(May require changes to meet local legislation)

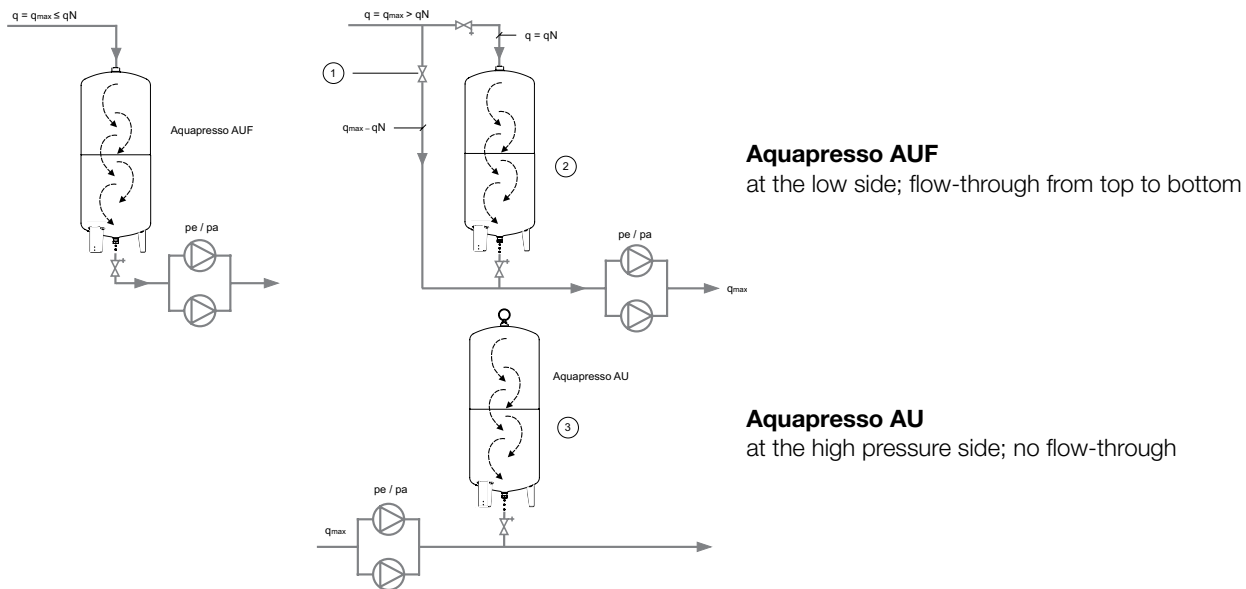

1. Bypass open, remove handwheel
2. p_0 at least 0,5 bar below the minimum supply pressure
3. $p_0 = 0,9$ working pressure of the peak load pump, at least 0,5 bar below the working pressure

Aquapresso A...F

DN bypass with q_{max}

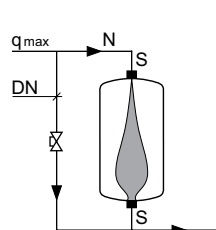

q_{max} m ³ /h	0,6	1,0	1,7	3,0	7,3	11,5	15,0	19,5	25,0	31,0	40,0	50,0
	DN Bypass											
ADF 8–12	■	•	•	•	•	•	•	•	•	•	•	•
ADF 18–35	■	•	•	•	•	•	•	•	•	•	•	•
ADF 50–80	■	■	■	15	25	•	•	•	•	•	•	•
AUF 140–500	■	■	■	■	25	32	•	•	•	•	•	•
AGF 700	■	■	■	■	■	25	32	50	•	•	•	•
AGF 1000–1500	■	■	■	■	■	■	■	32	40	65	•	•
AGF 2000–3000	■	■	■	■	■	■	■	■	■	32	50	•

Aquapresso with larger flow-through recommended

$q \leq q_N$ no bypass required

Zeparo Cyclone

Comprehensive range of products for sludge and magnetite separation in heating and cooling water systems. The number of potential applications as well as their modular construction is second to none. The **new cyclonic technology** takes dirt separation efficiency to the next level.



Key features

> High efficiency independent of dimension

Separation efficiency increases together with flow velocity. The pressure drop remains stable regardless of the amount of dirt collected. Even higher protection for higher flows, e.g. in cooling applications. Suitable for up to 300 kW of system output.

> Cleans and protects the installation

Protects critical investments such as boilers, pumps, valves, chillers, and calorimeters, from dirt-related malfunction and failure. No risk of clogging - the dirt collected can be easily and quickly flushed out with the help of the drain valve. Reduces maintenance and associated costs over entire system lifetime.

> Magnet Accessory

Optimises separation efficiency even further for sludge and magnetite (black iron oxide) deposits that consist of finer particles. Combines magnetic separation and thermal insulation. Available in a set with the Zeparo Cyclone or as a separate accessory.

> Horizontal and vertical mounting

The unique cyclonic technology works in every position, allowing the Zeparo Cyclone to be mounted in vertical pipes as well.

Technical description

Application:

Heating and chilled water systems.

Media:

Non-aggressive and non-toxic system media.
Addition of antifreeze agent up to 50%.

Pressure:

Max. admissible pressure, PS: 10 bar
Min. admissible pressure, PSmin: 0 bar

Temperature:

Max. admissible temperature, TS: 120 °C
Min. admissible temperature, TSmin: -10 °C

Material:

Body: Brass
Cyclone insert: PPS Ryton.
Gaskets: EPDM

Marking:

Body: PN, DN, flow direction arrow.
Label with TS and TSmin.

Transportation and storage:

In dry places.

Magnet and Thermal insulation:

Magnet: NdFeB with Ni-Cu-Ni cover/ protection against rust.
Insulation: Expanded polypropylene (EPP), anthracite. Insulation value approx. 0.035 W/mk.
Fire rating B2 according to DIN 4102 and E in accordance with EN 13501-1.
Max. temperature: 110 °C.
Min. temperature: 6-8 °C (above dew point).

Quick selection

Heating

Example:

Heating system with a pipe DN 25 and 1000 l/h flow. Draw a line from the point 1 m³/h to required dimension DN20/25 and read on the line for pressure drop 2,8 kPa.

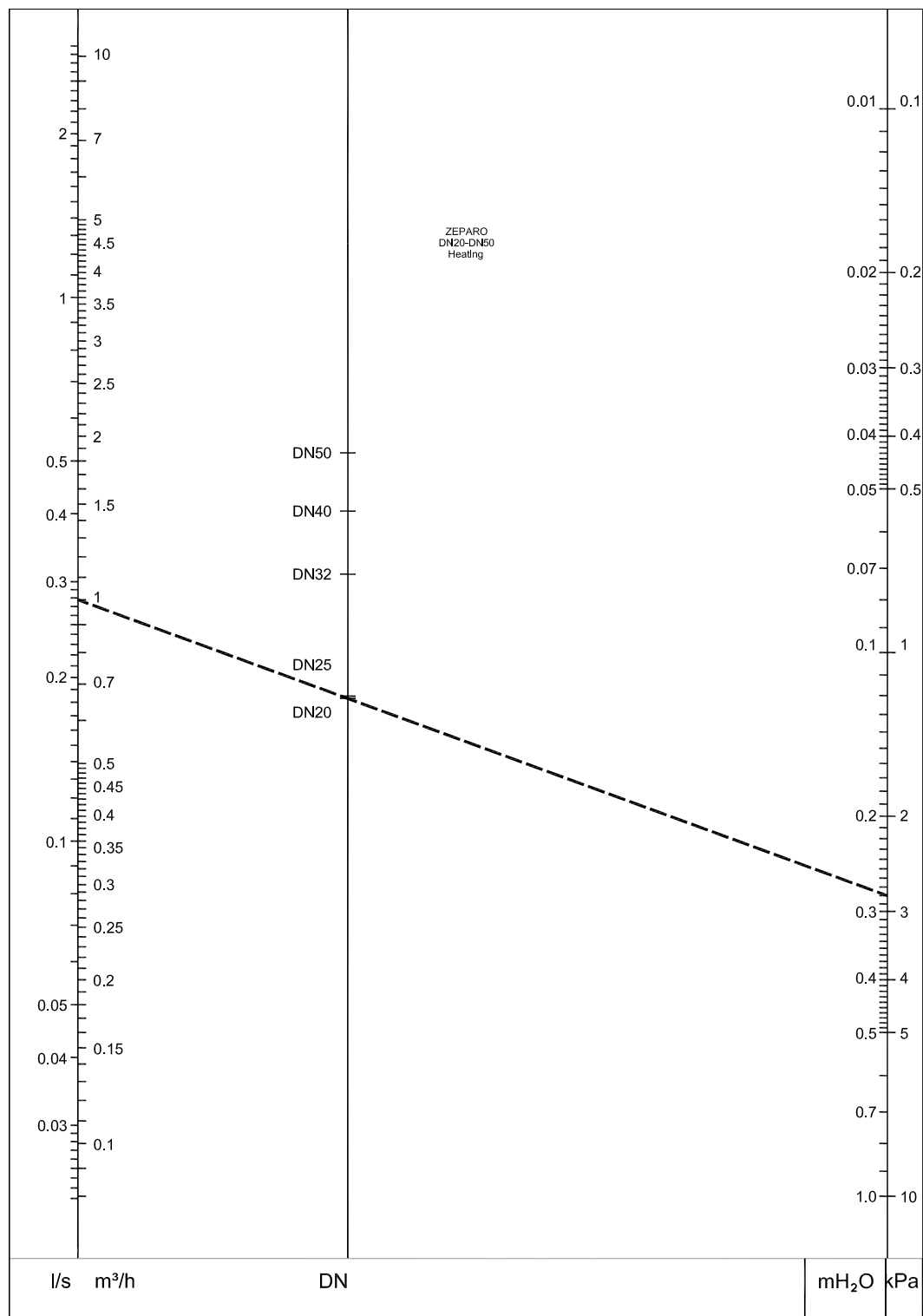

For exact calculations please use the HySelect software.

Cooling

Example:

Cooling system with a pipe DN 32 and 3,5 m³/h flow. Draw a line from the point 3,5 m³/h to required dimension DN32 and read c the line for pressure drop 7,2 kPa.

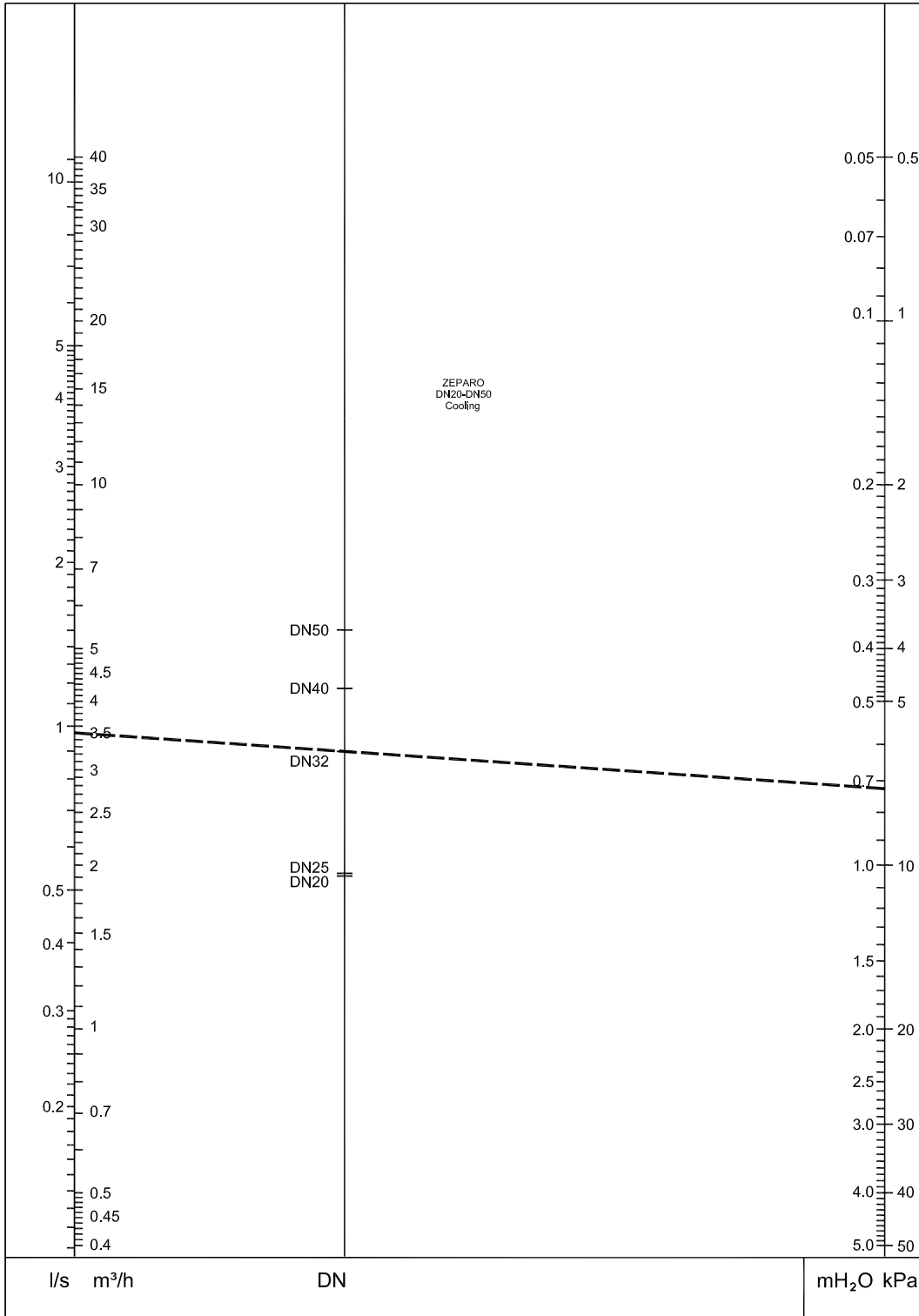

For exact calculations please use the HySelect software.

Application examples

System with boiler

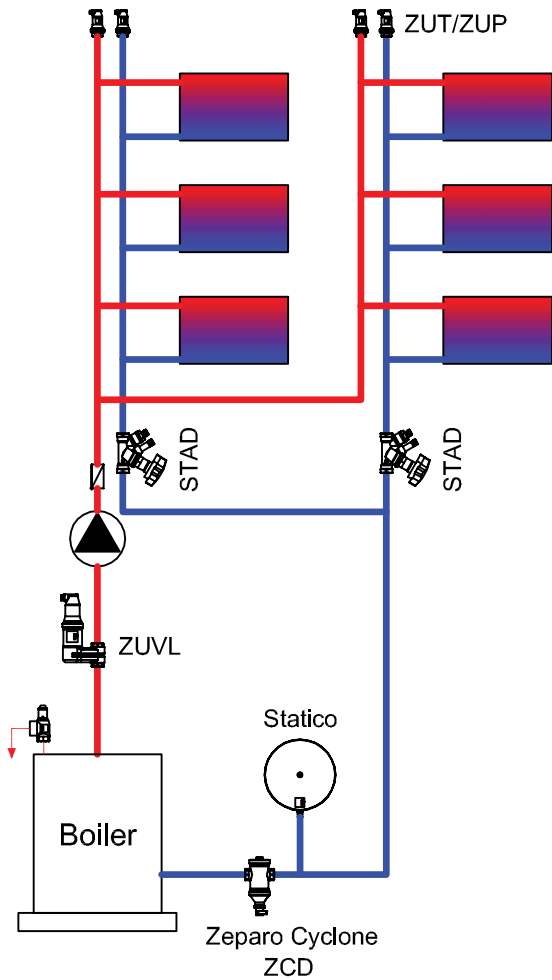

The Zeparo Cyclone dirt separator should be mounted either on the return in front of the unit to be protected or directly in front of the energy source.

There is no minimum distance required to pipe bends etc. before or after the Zeparo Cyclone.

System with heat exchanger

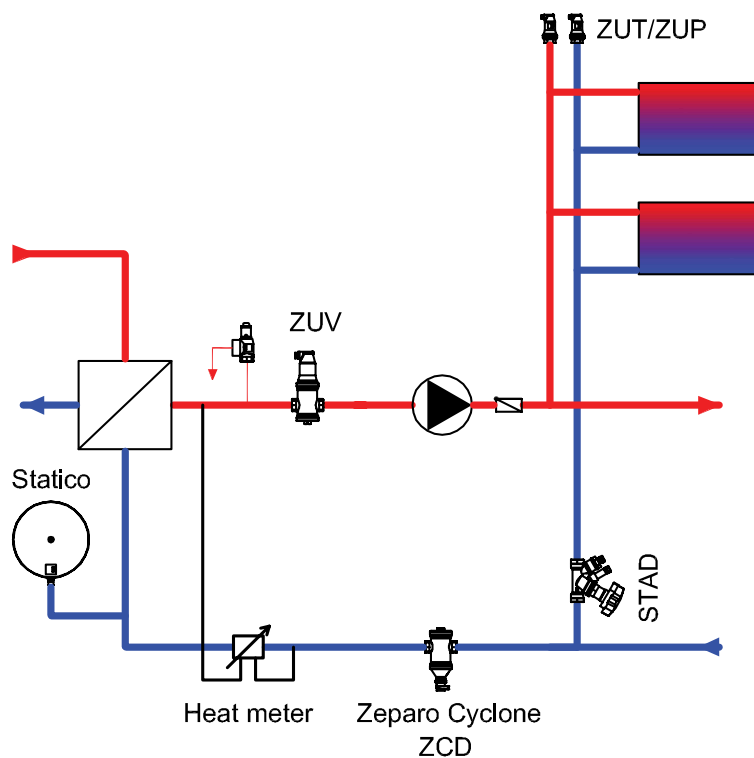

Zeparo G-Force

Comprehensive range of products for sludge and magnetite separation in heating and cooling water systems. The number of potential applications as well as their modular construction is unique. Its **new cyclonic technology** takes dirt separation efficiency to the next level.

Key features

> High efficiency independent of dimension

Separation efficiency increases together with flow velocity. The pressure drop remains stable regardless of the amount of dirt collected. Even higher protection for higher flows, e.g. in cooling applications. Suitable for heating and cooling installations.

> Cleans and protects the installation

Protects critical investments such as boilers, pumps, valves, chillers, and calorie meters, from dirt-related malfunction and failure. No risk of clogging - the dirt collected can be easily and quickly flushed out with the help of the drain valve. Reduces maintenance and associated costs over entire system lifetime.

> Magnet Accessory

Optimizes separation efficiency even further for sludge and magnetite (black iron oxide) deposits that consist of finer magnetic particles. Easy handling and cleaning.

> Air separation

Due to the cyclonic effect, pressure in the centre of the device is below system pressure, causing more air bubbles to be released than in standard separators. The air is concentrated in the centre forming larger bubbles, which can raise in the upper section of the G-Force where there is less flow. This function requires an additional ZUTX automatic air vent.



Technical description

Application:

Heating and chilled water systems.

Media:

Non-aggressive and non-toxic system media.
Addition of antifreeze agent up to 50%.

Pressure:

Max. admissible pressure, PS:
PN 16 and PN 25 (see each product)
Min. admissible pressure, PSmin: 0 bar

Temperature:

Max. admissible temperature, TS:

- PN16: 110 °C

- PN25: 180 °C

Min. admissible temperature, TSmin:

-10 °C

Material:

Steel. Color beryllium.

Marking:

Body: flow direction arrow.

Label: DN, PN, TS and TSmin.

Connection:

Flanges according to EN 1092-1.
Welding ends.

Transportation and storage:

In dry places.

Standard:

Constructed according to
PED 2014/68/EU.

Quick selection

Heating

Example:

Heating system with a pipe DN 100 and 31 m³/h flow. Draw a line from the point 31 m³/h to required dimension DN 100 and read on the line for pressure drop 9 kPa.

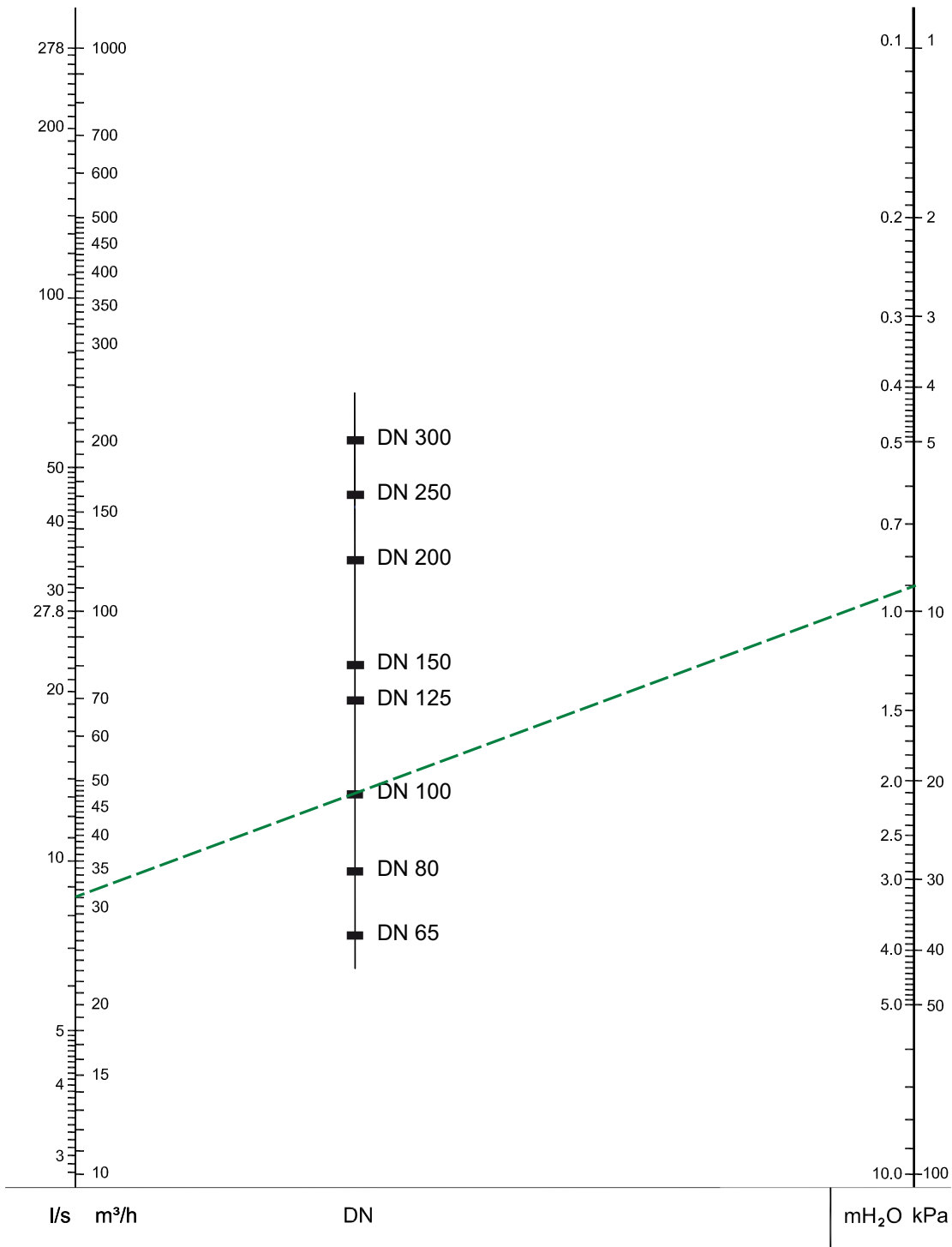

Flow rate must not exceed the max flow rates of the relevant dimension.
For exact calculations please use HySelect software.

Volumes and Flows

DN	VN [l]	qN [m³/h]	qN_{max} [m³/h]
65	12	10	40
80	25	18	56
100	28	37	95
125	71	68	148
150	78	100	216
200	239	200	375
250	583	345	575
300	624	540	815

VN = Nominal volume

qN = Nominal flow/flow rate

qN_{max} = Maximum flow

Application examples

System with boiler - PN16

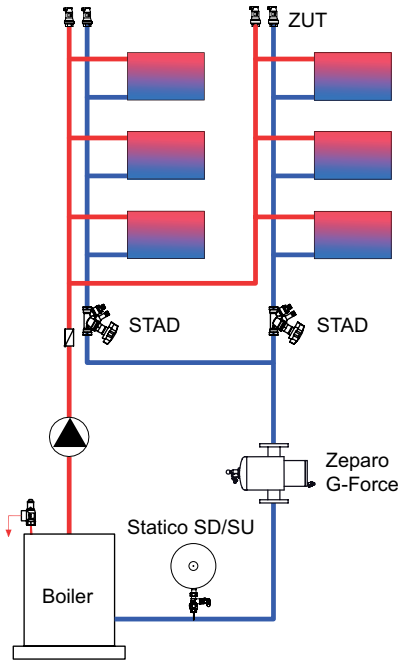

System with heat exchanger

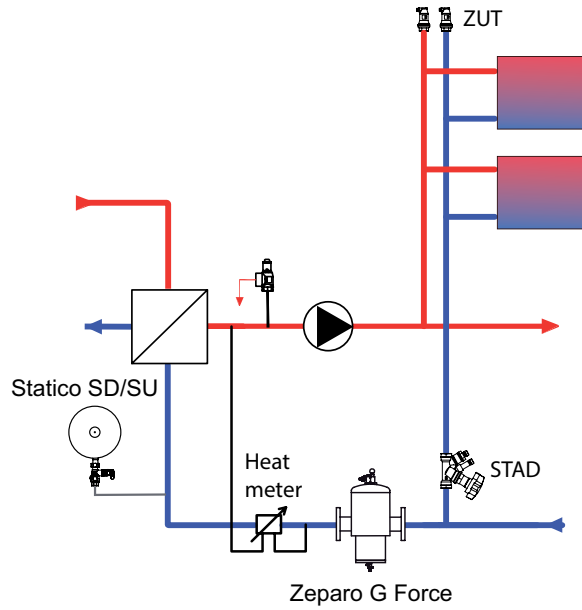

System with boiler - PN25

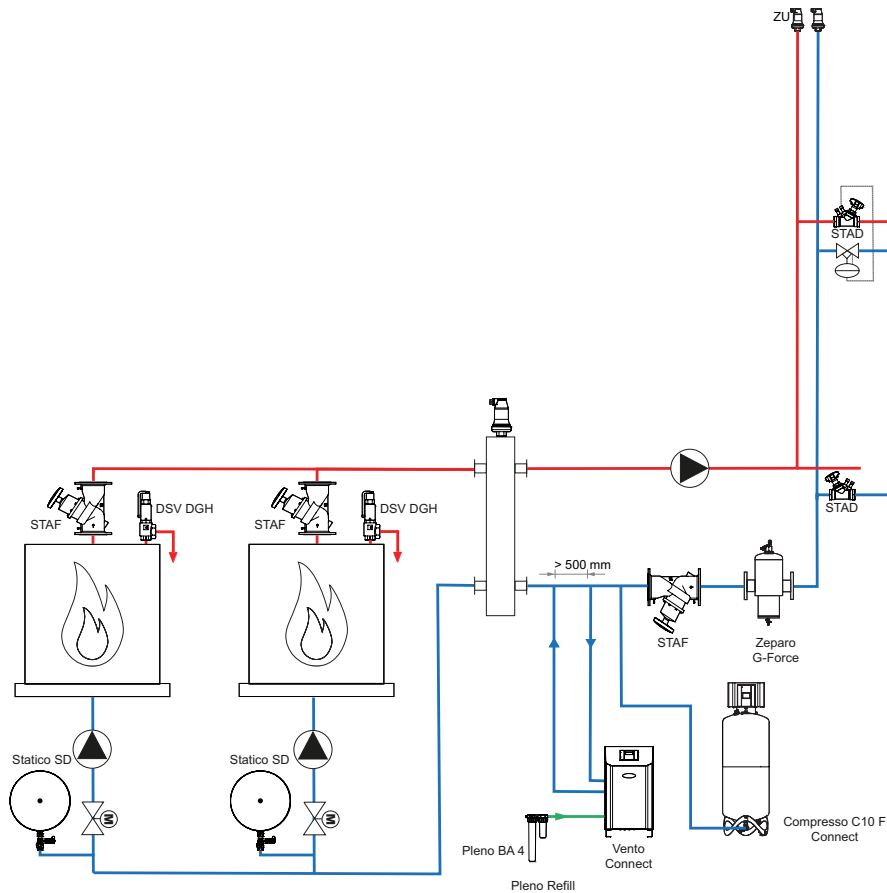

The Zeparo G-Force should be mounted either on the return in front of the unit to be protected or directly in front of the energy source. There is no minimum distance required to pipe bends etc. before or after the Zeparo G-Force.

Zeparo ZT turnable

Comprehensive range of products for the venting and separation of microbubbles, sludge, air and magnetite in waterborne heating and cooling systems, and for the protection of key system components such as pumps, boilers, chillers and calorie meters. Unique variety of applications, exceptional modular structure. The improved Helistill separator provides sensational efficiency.



Key features

- > **Cleans and protects the installation**
No risk of clogging. Reduces maintenance and associated costs over system lifetime.
- > **Custom fit**
The separation chamber can be rotated 360 degrees, allowing the Zeparo ZT to be mounted in every position.
- > **Magnet Accessory**
Optimizes separation efficiency for sludge and even for finer magnetic particles. Can be ordered together with the Zeparo ZT or as a standalone accessory.
- > **Easy cleaning**
Drain can be removed without pressure, allowing for easy cleaning of the separator.

Technical description

Application:

Heating and chilled water systems.

Media:

Non-aggressive and non-toxic system media.
Addition of antifreeze agent up to 50%.

Pressure:

Max. admissible pressure, PS: 10 bar
Min. admissible pressure, PSmin: 0 bar

Temperature:

Max. admissible temperature, TS: 110 °C
Min. admissible temperature, TSmin: -10 °C

Material:

Body: Brass
Inserts: PP 30% GF (plastic)
Clip: springsteel EN 10270-1 SH

Transportation and storage:

In frostless, dry places.

Magnet and Thermal insulation:

Magnet: NdFeB with Ni-Cu-Ni cover/ protection against rust.
Insulation: Expanded polypropylene (EPP), anthracite.
Insulation value approx. 0.035 W/mk.
Fire rating B2 to DIN 4102 and E in accordance with EN 13501-1.
Max. temperature: 110 °C.
Min. temperature: 6-8 °C (above dew point).

Diagram

Approx. pressure loss (Δp) – Separator

Zeparo ZTV, ZTD, ZTM, ZTK, ZTKM

DN 20 - DN 32

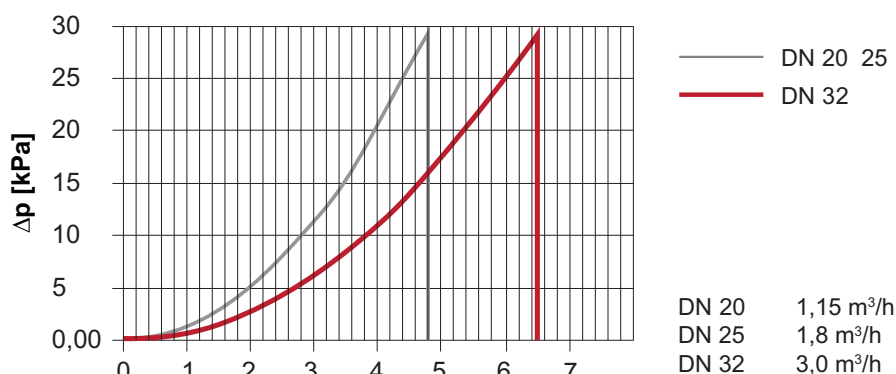

Zeparo DN 20-32 should only be used $\leq q_N$

DN 20	1,15 m³/h
DN 25	1,8 m³/h
DN 32	3,0 m³/h

Application examples

The Zeparo ZT dirt separator should be mounted either on the return before the unit to be protected, or directly in front of the energy source. There is no minimum distance required to pipe bends etc. before or after the Zeparo ZT.

System with boiler

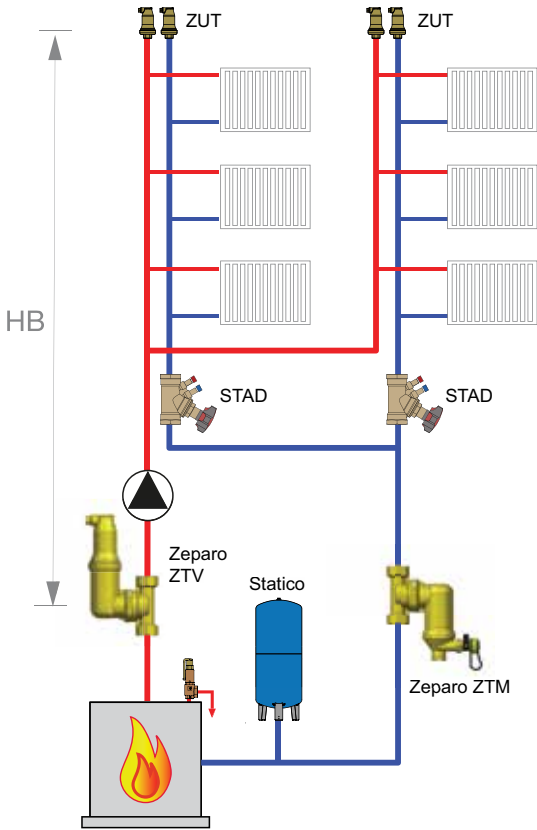

Wall-mounted gas boiler

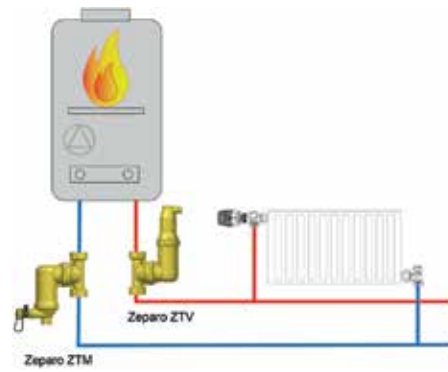

System with heat exchanger

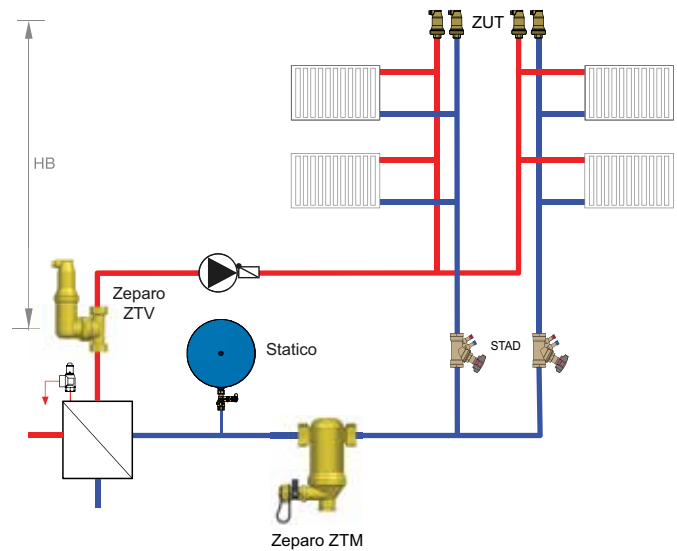

Chiller

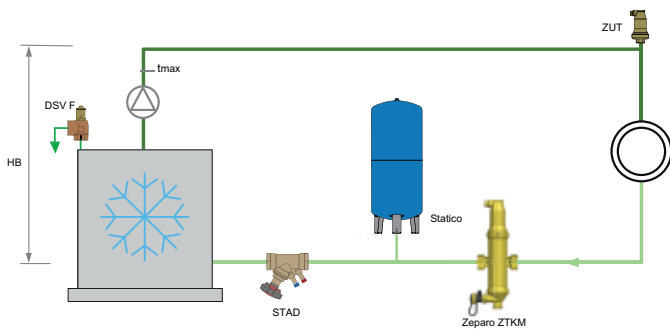

Zeparo ZU

Comprehensive range of products for venting and separation of micro bubbles, sludge, oxygen and magnetite in heating, solar and cooling water systems. The diversity of the applications as well as their modular construction is unique. The helistill separator makes these products incredibly efficient.

Key features

- > **Cleans and protects the installation**
No risk of clogging. Reduces maintenance and associated costs over system lifetime.
- > **Magnet Accessory**
Optimizes separation efficiency for sludge and even for finer magnetic particles. Can be ordered together with the Zeparo ZT or as a standalone accessory.
- > **Easy cleaning**
Drain can be removed without pressure, allowing for easy cleaning of the separator.



Technical description

Application:

Heating, solar and chilled water systems.

Media:

Non-aggressive and non-toxic system media.
Addition of antifreeze agent up to 50%.

Pressure:

Max. admissible pressure, PS: 10 bar
Min. admissible pressure, PSmin: 0 bar

Temperature:

Max. admissible temperature, TS: 110 °C
Min. admissible temperature, TSmin: -10 °C

Zeparo ZUTS, ZUVS solar:

Max. admissible temperature, TS: 160 °C
Min. admissible temperature, TSmin: -10 °C

Material:

Vent, body, linkage: Brass
Helistill separator: Plastic PP - 30 % glass fibre
Gaskets: EPDM -10 – 110 °C | FPM (Viton) -10 – 160 °C
Float: Plastic -10 – 110 °C
Stainless steel -10 – 160 °C

Transportation and storage:

In frostless, dry places.

Diagrams

Approx. pressure loss (Δp) – Separator

Zeparo ZUV, ZUD, ZUM, ZUKM, ZUCM

DN 20-40

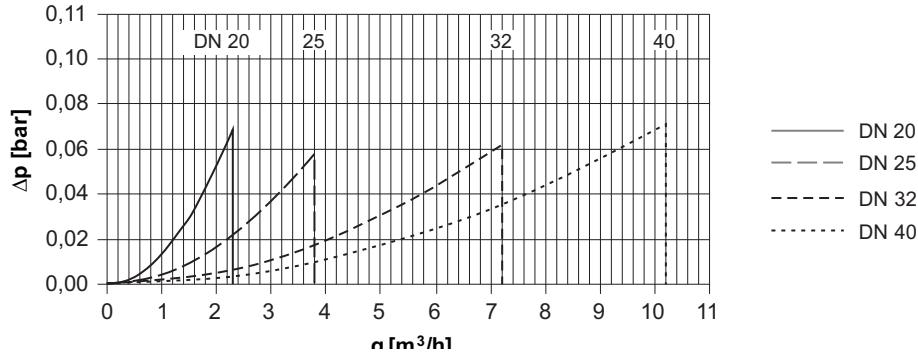

Zeparo DN 20-40 must operate within the limits $\leq q_N$.

Maximum system temperatures and static height above separator

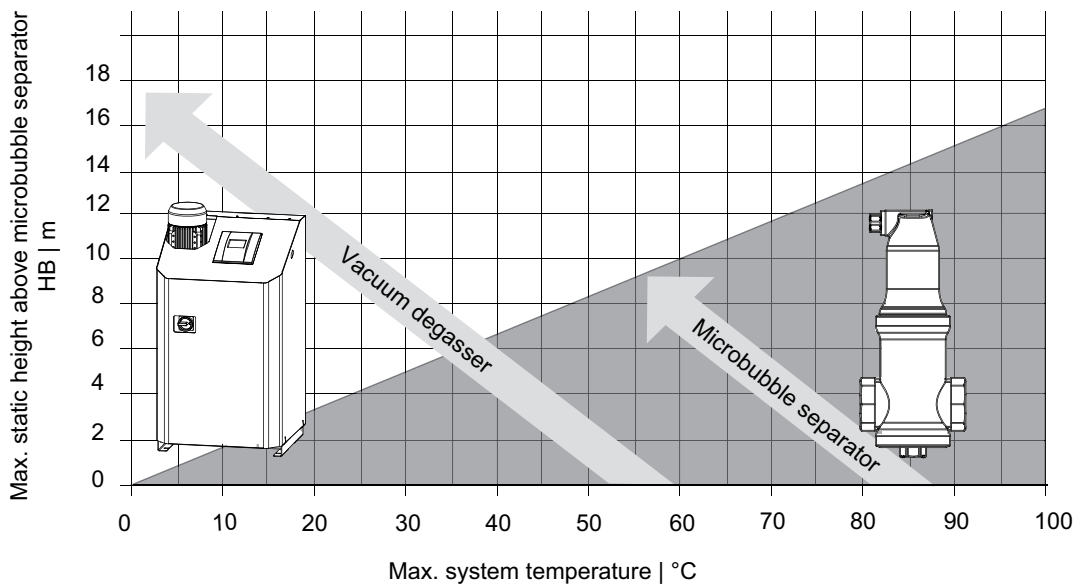

Application examples

The following circuit drawings illustrate preferred solutions. Alterations are possible under the condition that applicable HB limit values are maintained.

Heating system

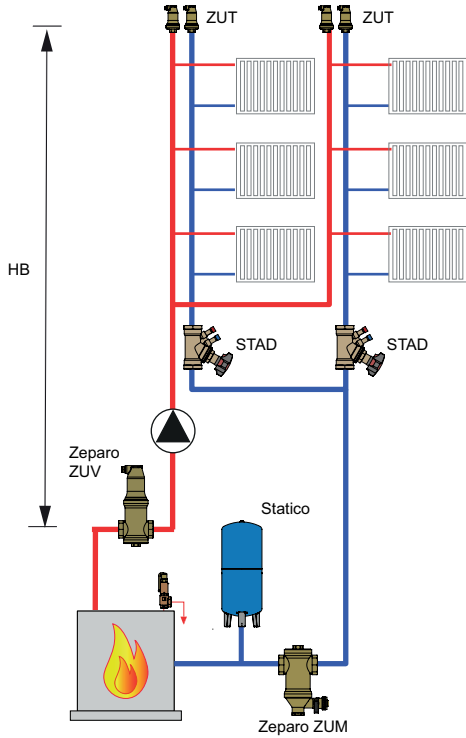

Wall-mounted gas boiler

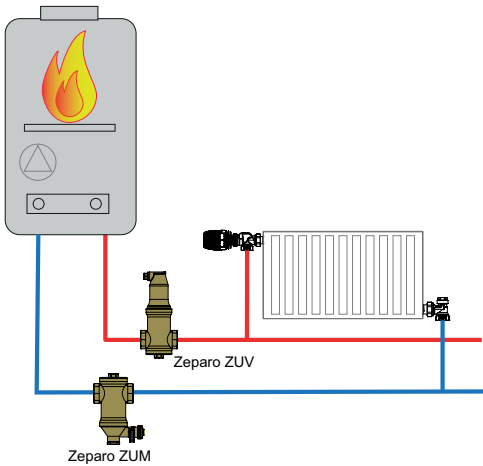

Heat pump system

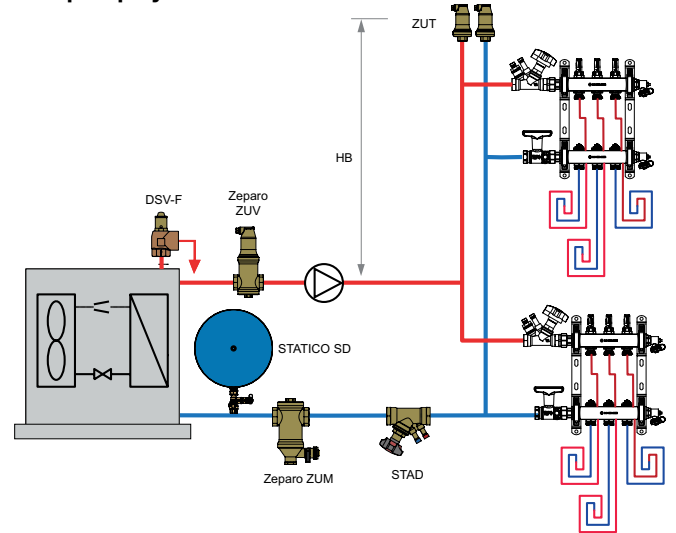

Solar heating

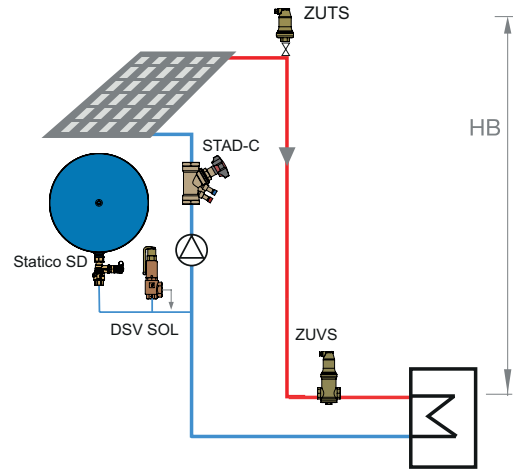

Cooling system

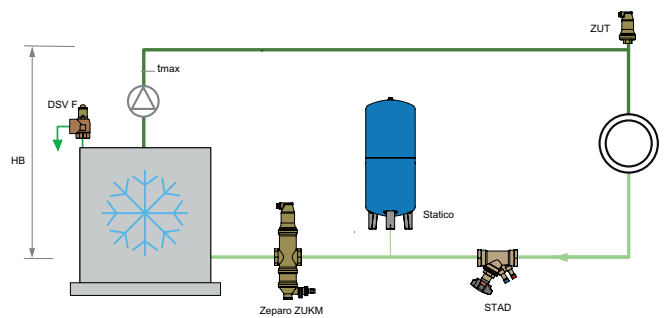

Low-loss headers

Primary volumetric flow V1. Secondary volumetric flow V2.

Case A:

Primary flow $V1 > \text{Secondary flow } V2$

To be used where secondary flow V2 mixes with the return flow at customer circuits, thereby getting reduced to such levels that the effectiveness of generators is no longer ensured. Not suitable for condensating boilers.

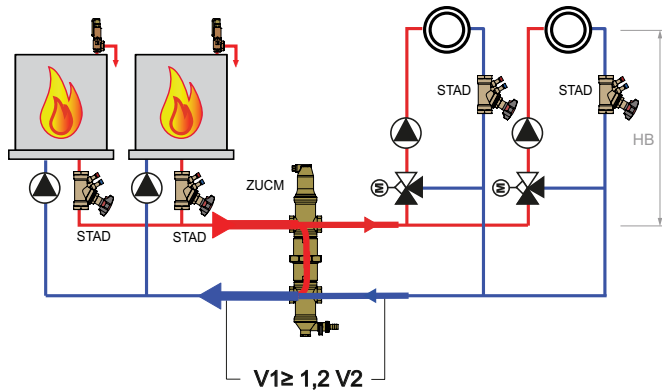

ZUCM	V1 [m3/h]
20	$\leq 1,25$
25	≤ 2
32	$\leq 3,7$
40	≤ 5

Case B:

Primary flow $V1 < \text{Secondary flow } V2$

Used primarily with condensating boilers in combination with underfloor heating systems. Secondary flow V2 of the underfloor heating is higher than the flow V1 produced by the condensating boiler. Water heaters should be connected on the boiler side before the header.

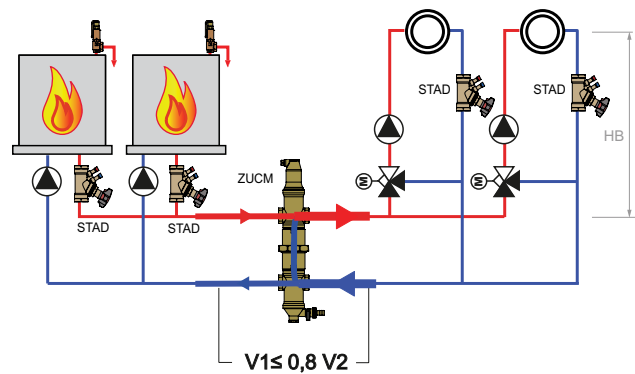

ZUCM	V1 [m3/h]
20	$\leq 1,25$
25	≤ 2
32	$\leq 3,7$
40	≤ 5

Zeparo ZIO

For applications of all sizes, the Zeparo range offers a complete, reliable solution for problems with air and sludge in heating, solar and chilled water systems – from initial venting to the separation of the tiniest and finest magnetite particles. The helistill separator makes these products incredibly efficient. The Zeparo Industrial have been specially developed to meet the high demands of large installations, and they have one objective: to achieve an air-free, sludgefree installation without the use of filters, which become clogged or require regular maintenance.



Key features

> Cleans and protects the installation

Protects critical investments from malfunction and even failure due to dirt, such as boilers, pumps, valves, chillers, and calorimeter meters. No clogging risk. Reduces maintenance of equipment needed over system lifetime and associated costs.

> Magnet Accessory

Optimizes separation efficiency even further for sludge and magnetite (black iron oxide) deposits which consist of finer magnetic particles. Easy handling and cleaning.

Technical description

Application:

Heating, solar and chilled water systems.

Media:

Non-aggressive and non-toxic system media.
Addition of antifreeze agent up to 50%.

Pressure:

Max. admissible pressure, PS: 10 bar
Min. admissible pressure, PSmin: 0 bar

Temperature:

Max. admissible temperature, TS: 110°C
Min. admissible temperature, TSmin: -10°C

Material:

Steel. Color beryllium.

Connection:

Flanges PN 16 according to EN 1092-1.

Standard:

Constructed according to PED 2014/68/EU.

Transportation and storage:

In frostless, dry places.

Volumes and Flows

DN	VN [l] ZIO...F	qN [m ³ /h]	qN _{max} [m ³ /h]
50	7	11	25
65	7	19	42
80	16	26	65
100	17	44	100
125	27	67	155
150	51	95	222
200	110	170	395
250	210	306	618
300	370	435	890

VN = Nominal volume

qN = Nominal flow/flow rate

qN_{max} = Maximum flow

Diagrams

Approx. pressure loss (Δp) – Separator

Zeparo ZIO

DN 50 – DN 150

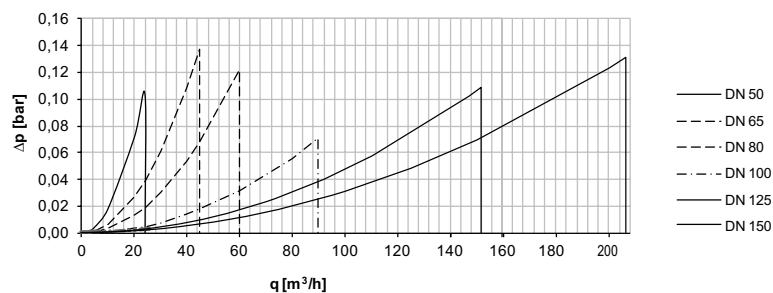

Zeparo ZIO

DN 200 – DN 300

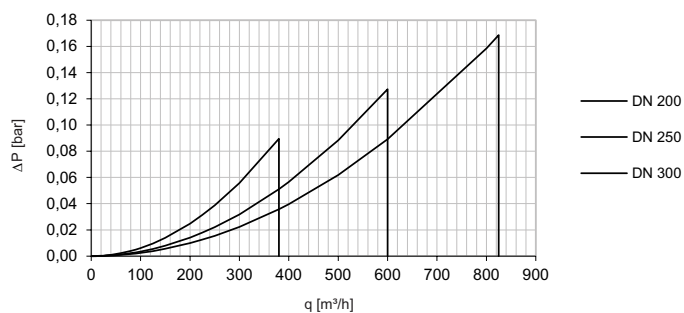

Zeparo DN 200 – DN 300 operation is limited to:

Continuous flow \leq qN

Intermittent flow \leq qN_{max}

Application examples

System with boiler

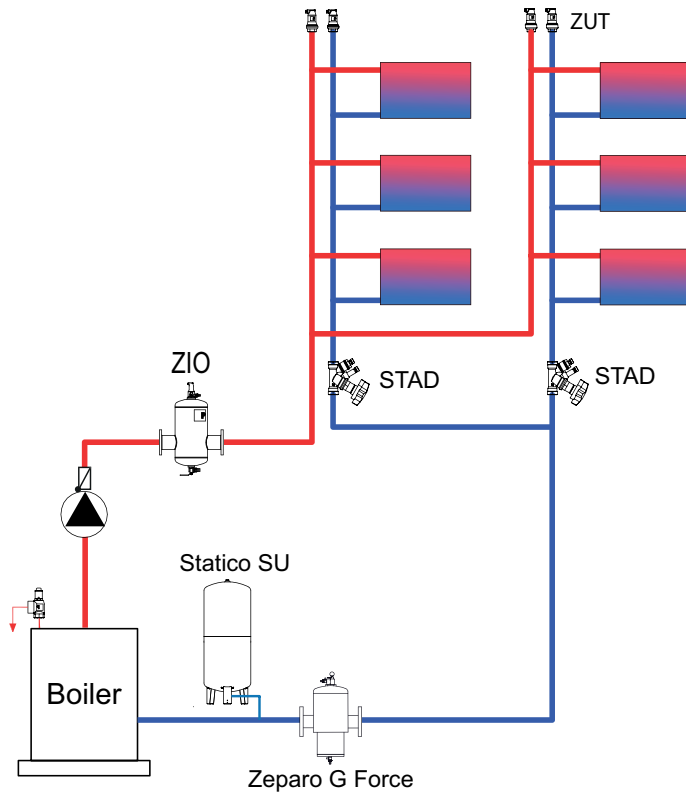

System with heat exchanger

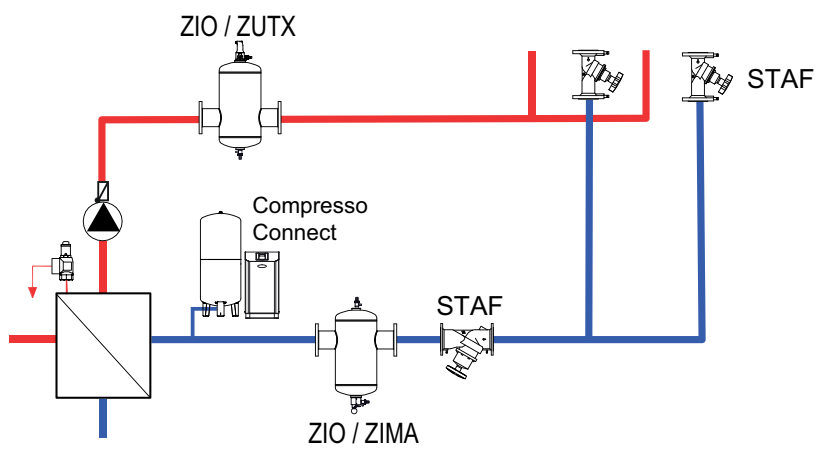

Simply Vento

Simply Vento is a *cyclonic* vacuum degasser for heating systems. Through the process of rotating the water in a special cyclonic vacuum vessel, the gases are separated completely from the water. Its use is particularly recommended where performance, compact design and precision are required. The **BrainCube Connect** control panel allows a new level of connectivity, enabling communication with the BMS system, other BrainCubes as well as remote operation of the pressurisation system through live viewing.



Key features

- > **Higher Efficiency Cyclonic vacuum degassing**
Significantly higher efficiency than most other vacuum degassing systems.
- > **Optional sound-absorbing wall bracket**
For installation locations particularly sensitive to structure-borne sound
- > **Plug & Play installation and start-up**
Connect unit to the installation
Plug in power supply
Follow the instructions displayed on the BrainCube
- > **Compact design for floor and wall hanging installation**
- > **Remote Access and Troubleshooting**
Integrated standard connections to our IMI Webserver and to BMS.

Technical description – Control unit TecBox

Applications:

Heating systems. For systems according to EN 12828, SWKI HE301-01, EN 12976, ENV 12977, EN 12952, EN 12953,

Media:

Non-aggressive and non-toxic system media.
Addition of antifreeze agent up to 50%.

Pressure:

Min. admissible pressure, PSmin: -1 bar
Max. admissible pressure, PS: 10 bar

Temperature:

Min. admissible temperature, TSmin: 0°C
Max. admissible temperature, TS: 90°C
Max. admissible ambient temperature, TA: 40°C
Min. admissible ambient temperature, T Amin: 0°C

Supply voltage:

1 x 230 V (± 10 %) / 50 Hz

Electrical connections:

Onsite fuses according to power demand and local norms
3 potential free outputs (NO) for external alarm indication (230V max. 2A)
1 RS 485 In/Output
1 Ethernet RJ45 plug socket
1 USB Hub plug socket

Enclosure class:

IP54 according to EN 60529

Mechanical connections:

Sin1: inlet from the system G1/2"
Sout: outlet to the system G1/2"

Material:

Metal components with medium contact: carbon steel, cast iron, stainless steel, AMETAL®, brass, gun metal.

Transportation and storage:

In frostless, dry places.

Standard:

Constructed according to LV-D. 2014/35/EU
EMC-D. 2014/30/EU

Function, Equipment, Features

Control unit TecBox

- BrainCube Connect control for an intelligent, fully automatic, safe system operation. Self-optimising with memory function.
- Resistive 3.5" TFT illuminated colour touch display. Web-based interface with remote control and live view. User-friendly, operation-orientated menu layout with slide and tap operation, step-by-step start up procedure guide and direct help in pop-up windows. Representation of all relevant parameters and operation status in plain text and/or graphical, multilingual.
- Standardised integrated connections (Ethernet, RS 485) to the IMI webserver and BMS (Modbus and IMI Pneumatex protocol).
- Software updates and data logging possible via USB connection
- Data logging and system analysis, chronological message memory with prioritisation, remotely controllable with live view.
- High quality metal cover.

Vacuum Degassing

- Flow capacity of approx. 200 l/h for system degassing.
- Vacusplit: Degassing programs for permanent operation with cyclonic technology. Gas under saturation of system water of nearly 100%.
- Oxystop degassing: Safely degasses system in a specially designed cyclone vessel (inside the Tecbox). Protects the system against corrosion.

Principle scheme

Simply Vento

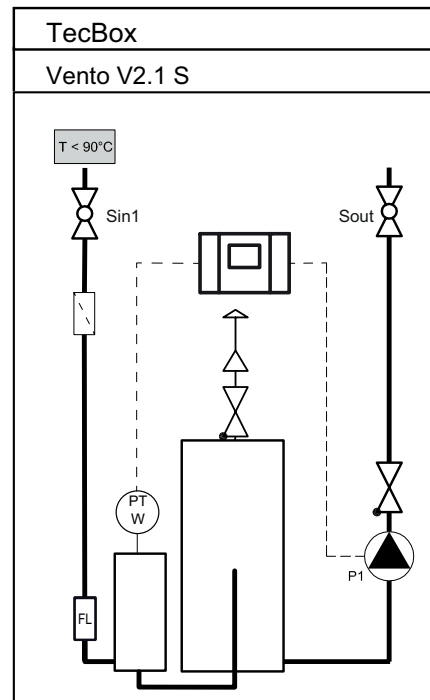

DNe standard values for connection pipes for Simply Vento

	Simply Vento	
Length up to approx. 10 m	DNe	25
Length up to approx. 20 m	DNe	25
Length up to approx. 30 m	DNe	32

Quick selection

Operation range dpu
Type

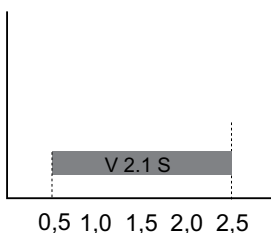

dpu

		Simply Vento
dpu min.	bar	0.5
dpu max.	bar	2.5

Installation

Simply Vento

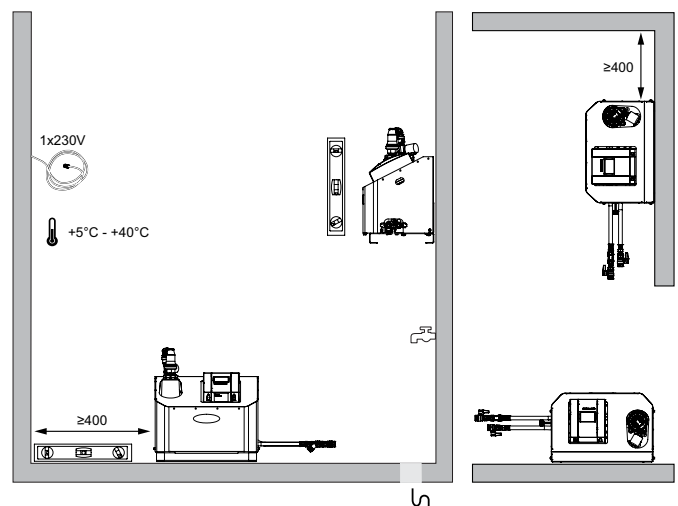

Application examples

Example for heating systems, return temperature $t_r \leq 90^\circ\text{C}$

(May require changes to meet local legislation)

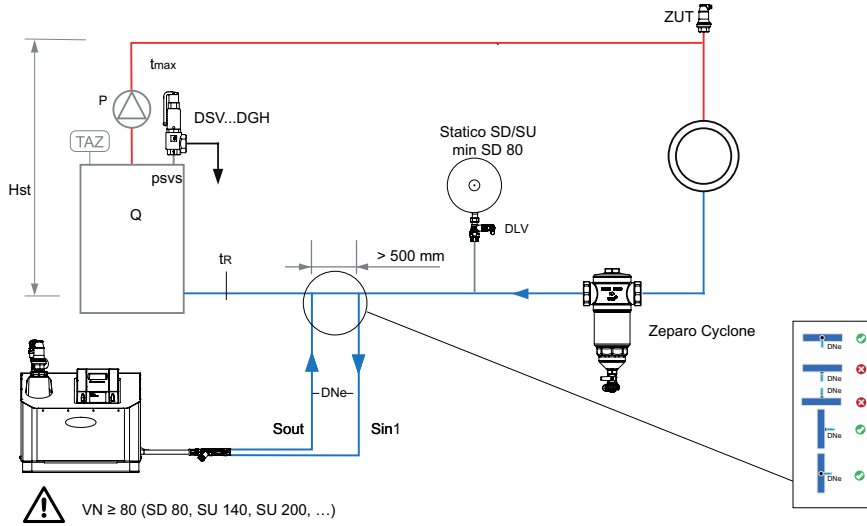

Zeparo

Air vent Zeparo ZUT or ZUP at each high point for venting during the filling and during the draining process.
 Zeparo Cyclone: Separator for sludge and magnetite in each system in the main return to the heat generator.

Vento Connect

Vento Connect is a cyclonic vacuum degasser for heating and solar systems, and chilled water systems. Its use is particularly recommended where high performance, compact design and precision are required. The industrial version VI is especially designed for high pressure applications up to 20.5 bar. The new **BrainCube Connect** control panel allows a new level of connectivity, enabling communication with the BMS system, other BrainCubes as well as remote operation of the pressurisation system through live viewing.



Key features

- > **Higher efficiency cyclonic vacuum degassing**
Significantly higher efficiency than most other vacuum degassing systems.
- > **Direct degassing of make-up water**
For additional protection against corrosion.
- > **Easy Commissioning, Remote Access and Trouble-shooting**
Integrated standard connections to our IMI Webserver and to BMS.
- > **Vento Compact**
Compact design for floor and wall hanging installation
- > **Optional sound-absorbing wall bracket**
For Vento Compact in installation locations particularly sensitive to structure-borne sound

Technical description – Control unit TecBox

Applications:

Heating, solar and chilled water systems.
For systems according to EN 12828, SWKI HE301-01, EN 12976, ENV 12977, EN 12952, EN 12953

Media:

Non-aggressive and non-toxic system media.
Addition of antifreeze agent up to 50%.

Pressure:

Min. admissible pressure, PS_{min}: -1 bar
Max. admissible pressure, PS: see Articles

Temperature:

Min. admissible temperature, TS_{min}: 0°C
Max. admissible temperature, TS: 90°C
Max. admissible ambient temperature, TA: 40°C
Min. admissible ambient temperature, TA_{min}: 0°C

Supply voltage:

Vento V/VF:
1 x 230 V (± 10 %) / 50 Hz
Vento VI:
Main voltage: 3x400V (± 10%) / 50Hz (3P+PE)
Control voltage: 230V (± 10%) / 50Hz (P+N+PE)

Electrical connections:

Onsite fuses according to power demand and local norms
4 (V/VI) or 3 (VF) potential-free outputs (NO) for external alarm indication (230V max. 2A)
1 RS 485 In/Output
1 Ethernet RJ45 plug socket
1 USB Hub plug socket
Terminal strip in PowerCube for direct wiring (Vento VI).

Enclosure class:

IP54 according to EN 60529

Mechanical connections:

Vento V/VI:
Sin1: inlet from the system G3/4"
Sout: outlet to the system G3/4"
Swm: inlet water make-up G3/4"

Vento VF:

Sin1: inlet from the system G1/2"
Sout: outlet to the system G1/2"
Swm: inlet water make-up G3/4"

Material:

Metal components with medium contact: carbon steel, cast iron, stainless steel, AMETAL[®], brass, gun metal.

Transportation and storage:

In frostless, dry places.

Standard:

Constructed according to LV-D. 2014/35/EU
EMC-D. 2014/30/EU

Function, Equipment, Features

Control unit TecBox

- BrainCube Connect control for an intelligent, fully automatic, safe system operation. Self-optimising with memory function.
- Resistive 3.5" TFT illuminated colour touch display. Web-based interface with remote control and live view. User-friendly, operation-orientated menu layout with slide and tap operation, step-by-step start up procedure guide and direct help in pop-up windows. Representation of all relevant parameters and operation status in plain text and/or graphical, multilingual.
- Standardised integrated connections (Ethernet, RS 485) to the IMI webserver and BMS (Modbus and IMI Pneumatex protocol).
- Software updates and data logging possible via USB connection
- Data logging and system analysis, chronological message memory with prioritisation, remotely controllable with live view.
- Periodical automatic self-test, daily checking the vacuum. The BrainCube Connect generates an alarm if necessary.
- High quality metal cover.

Vacuum Degassing

- Flow capacity of approx. 1000 l/h (Vento V/VI) and 200 l/h (Vento Compact) for system degassing.
- Vacusplit: Degassing programs for permanent operation with cyclonic technology. Gas under saturation of system water of nearly 100%. Eco automatic operation when no air is detected, savings on electricity consumption of the pump.
- Oxystop degassing: Direct degassing of make-up water. Significant oxygen reduction in the make-up water. Safely degasses both system and make-up water in a specially designed cyclone vessel (inside the Tecbox), with the advantage of low keeping temperature of the expansion vessel, without the need to insulate the vessel. Protects the system against corrosion.

Water make-up

- Fillsafe: water-make up monitoring and control with integrated contact water flow meter and solenoid valve.
- Connection for optional Pleno P BA4R/AB5(R) water make-up devices for tap water protection following EN 1717.
- Softsafe monitoring and control for an optional refill water treatment device.

DNe standard values for connection pipes for Vento V/VI/Compact

		V 2.1	V 4.1	V 6.1	V 8.1	V 10.1	V 14.1	VI 19.1	VI 25.1
Length up to approx. 10 m	DNe	25	25	25	25	25	25	25	25
Length up to approx. 20 m	DNe	25	25	25	25	25	25	25	25
Length up to approx. 30 m	DNe	32	32	32	32	32	32	32	32

Quick selection

Operation range dpu
Type

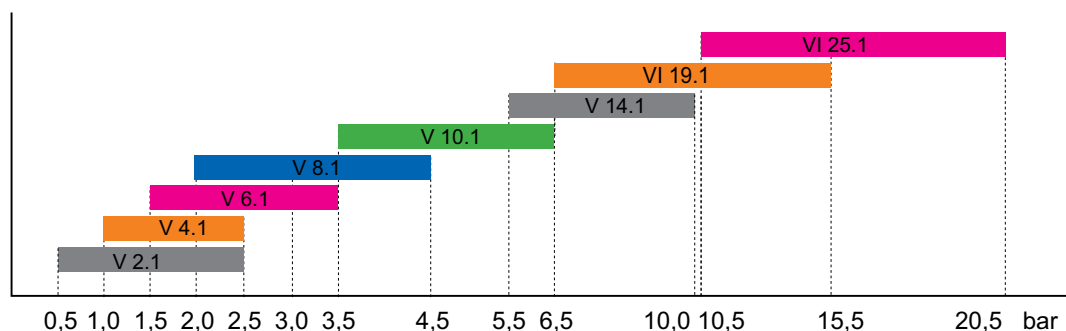

dpu

		V 2.1	V 4.1	V 6.1	V 8.1	V 10.1	V 14.1	VI 19.1	VI 25.1
dpu min	bar	0.5	1	1.5	2	3.5	5.5	6.5	10.5
dpu max	bar	2.5	2.5	3.5	4.5	6.5	10	15.5	20.5

Application examples

Vento V/VI/VF Connect for heating

TecBox with 1 pump, cyclonic vacuum degassing and Pleno P BA4 R for water make-up.

Example for heating systems, return temperature $t_r \leq 90^\circ\text{C}$

(May require changes to meet local legislation)

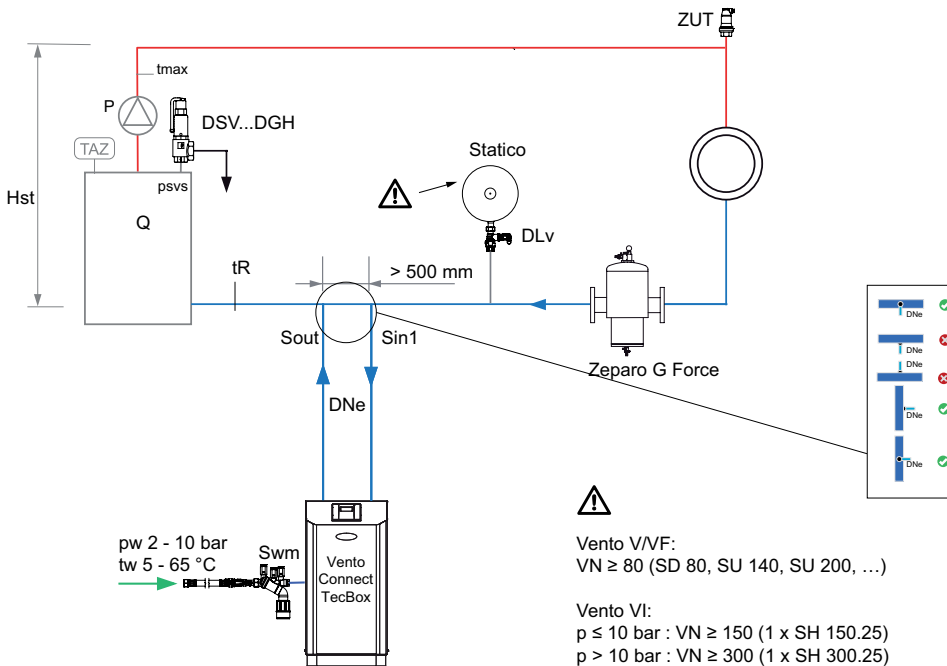

Vento V/VI 1.EC Connect for cooling

TecBox with 1 pump, cyclonic vacuum degassing, Pleno P AB5 R for water make-up and Pleno Refill for water treatment unit for softening or demineralising the make-up water.

Example for cooling systems, return temperature $0^\circ\text{C} < t_r \leq 5^\circ\text{C}$

(May require changes to meet local legislation)

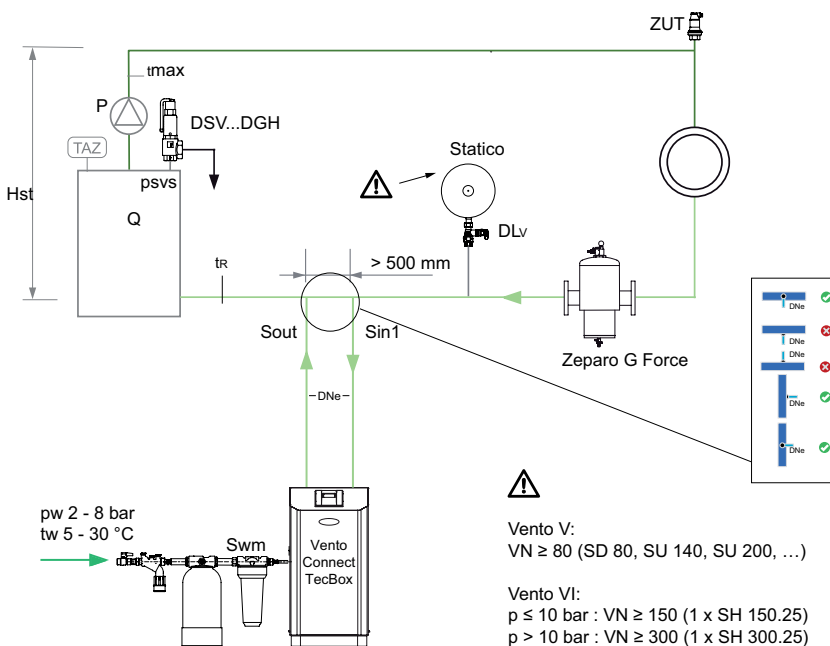

Zeparo G-Force for the central separation of sludge.

Zeparo ZUT for automatic venting during filling and during draining.

Further accessories, product and selection details, see: Datasheet *Pleno Connect*, *Zeparo* and *Accessories*.

Safety technology

Devices for sealed heating systems according to EN 12828 with $TAZ \leq 110^\circ\text{C}$

	Heated directly <i>with oil, gas, electricity, solid fuels</i>	Heated indirectly <i>heat exchanger with vapour or liquids</i>	Datasheet
General requirements			
TI Thermometer , display range $\geq 20\%$ above TAZ	•	•	Accessories
TAZ Temperature limiter according to EN 60730-2-9	•	• ¹⁾	Accessories
TC Temperature controller	•	•	
LAZ Low-water protection ²⁾ for roof top installations	•	–	Accessories
PI Manometer , display range $\geq 50\%$ above PSV	•	•	Accessories
SV Safety valve , EN 4126 for vapour emission	•	• ³⁾	Accessories
Pressure maintenance , e.g. Statico, Compresso, Transfero	•	•	Statico, Compresso, Transfero
Pressure maintenance monitoring device ⁴⁾ , e.g. Pleno	•	•	Pleno
Additional requirements for $Q > 300\text{ kW}$ / heat generator			
LAZ Low-water protection ²⁾	•	–	Accessories
ET Blow tank ⁵⁾	•	• ⁶⁾	Accessories
PAZ Pressure limiter	•	–	
Additional requirements with slow-action heating			
Emergency cooling through thermal discharge protection or safety heat consumer, e.g. with solid fuel boilers	•	–	

1) Temperature controller sufficient according to standard, but not recommended.

2) Minimum pressure or flow limiters can be used as an alternative. For central roof units above 300 kW not additionally, 1 low-water protection is sufficient.

3) Dimensioning for water discharge with 1 litre/kWh possible if the primary temperature does not exceed the evaporation temperature with the safety valve opening pressure psv.

4) Automatic water make-up device (e.g. Pleno) or minimum pressure limiter.

5) Substitution with additional TAZ and PAZ possible. EN 12828 does not contain constructive specifications. We recommend to proceed according to the known state of the art of the countries, e.g. SWKI HE301-01 in Switzerland or DIN 4751-2 in Germany.

6) Only if the vapour pressure p_v at flow temperature $t_{p_{max}}$ is bigger than safety valve opening pressure psv.

Application examples

Safety equipment according to EN 12828

(May require changes to meet local legislation)

Directly heated system

$Q > 300\text{ kW}$

1. Pressure maintenance e.g. Statico
2. Pressure maintenance monitoring device. Degassing with built-in water make-up, e.g. Vento V
3. Water make-up connection

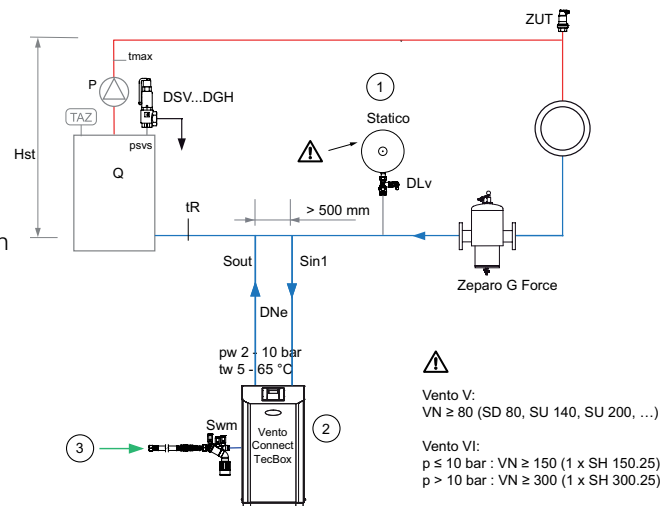

Terminology

General terms

BrainCube	Name of the new PNEUMATEX controls in Compresso, Transfero, Pleno and Vento.
TecBox	Name for PNEUMATEX compact control units consisting of hydraulic part and BrainCube control.
Quality features	airproof, silenrun, dynaflex, oxystop, vacusplit, helistill, leakfree, fillsafe, secuguard, flowfresh

Terminology equivalents

IMI	SWKI HE301-01	EN 12828
e	e	e
Hst	h_{st}	h_{st}
p0	p0	p0
pa	p_{ini}	p_{ini}
pe	p_{fin}	p_{fin}
psvs	p_{sv}	p_{sv}
pV	pV	p_v
Q	ϕ	ϕ
t	θ	θ

IMI	SWKI HE301-01	EN 12828
Ve	$V_{ex,tot}$	V_{ex}
Vg	V_{gen}	--
Vgsolar	V_{DK}	--
Vhs	V_{sto}	--
VN	V_N	V_N
Vs	V_{sys}	V_{System}
Vwr	V_{wr}	V_{wr}
X	X	--

Geometry

D	Diameter Characteristic diameter of the device.
H	Height (H, H1, H2, ...) Characteristic overall height of the device.
h	Installation dimensions (h, h1, h2, ...)
B	Width Characteristic overall width of the device.
I	Depth Characteristic overall width of the device
L	Length Characteristic overall length of the device or the fixture
si	Insulation thickness
m	Empty weight of the device at the time of delivery without the packaging.
S	Connection Characteristic dimension for the device connection.
S_{in}	Connection in Characteristic dimension for the device connection for streaming in media.
S_{out}	Connection out Characteristic dimension for the device connection for streaming off media.
Sv	Connection vessel Characteristic dimension for the device connection to the vessel.
Swm	Connection water make-up Characteristic dimension for the water make-up connection.
Sw	Connection dewatering Characteristic dimension for evacuation, dewatering operations.
R	Male thread, conical , ISO 7-1
Rp	Female thread, cylindrical , ISO 7-1
G	Female tread, male thread, cylindrical , ISO 228
DN	Nominal diameter Numeric size specifications for tube dimensions according to the pressure device directive.
PU	Packaging unit Standard packaging quantity in a box or pallet. For articles with the specifications of the PU please coordinate order quantities smaller than the PU with the sales office. Items within a PU always provide of a functional separate packaging.

Pressures

Hst	Static height Water column between the highest point of the system and the connecting branch of the expansion vessel, for water-controlled pressure-maintaining systems with pump (Transfero) referred to the suction joint of the pump.
Hst_m	Maximum static height for the deployment of bubble separators It depends on the temperature conditions at the place of installation of the separator.
p0	Minimum pressure Lower limit value for the pressure maintenance. It is mainly defined by the static height Hst and the vapour pressure pv. If the value is fallen short of the function of the pressure maintenance cannot be ensured. For large systems and temperature limits above 100°C the pressure limiting devices are triggered. <i>Statico, Aquapresso:</i> Pre set pressure to be set at the gas side. Be careful with respect to Aquapresso in drinking water systems! If the drinking water pressure falls short of the pre set pressure this may lead to pressure blows and to an increased bubble wear (Initial pressure pa). <i>Transfero, Compresso, Vento, Pleno:</i> The minimum pressure p0 is calculated by the BrainCube control from the static height Hst and the vapour pressure pv (TAZ).
pz_{min}	Minimum required equipment pressure e.g. NPSH requirement for pumps or boilers
pv	Vapour pressure According to EN 12828 the excess pressure towards the atmosphere to prevent evaporation.
pa	Initial pressure Lower threshold for an optimum pressure maintenance. During the operation it must always be above the minimum pressure. We recommend at least 0,3 bar. For systems with minimum pressure limiters this value must be selected such that the triggering of the limiters is prevented in all operating modes. With respect to PNEUMATEX devices with BrainCube control the initial pressure is calculated internally by the control. <i>Statico:</i> Pressure with minimum system temperature after feeding the water reserve. Water makeup devices in the sense of a pressure maintenance monitoring device according to EN 12828 must be triggered if the value is fallen short of. If the filling temperature is equal to the lowest system temperature the initial pressure corresponds to the filling pressure. e.g. heating systems: lowest system temperature ~ filling temperature ~ 10 °C. <i>Compresso, Transfero:</i> Pressure at which the pump or the compressor must be triggered. <i>Aquapresso:</i> Pressure of the drinking water network before the Aquapresso. It must also always be greater than the pre set pressure at flow conditions.
pe	Final pressure Upper threshold for an optimum pressure maintenance. It must be at least 0,5 bar below the safety valve response pressure. For systems with maximum pressure limiters it must be selected such that the triggering of the limiters is prevented in all operating modes. <i>Statico:</i> The highest pressure to be assumed after the max. system temperature has been achieved. <i>Compresso, Transfero:</i> The pressure at which the spill device must open at the latest. <i>Aquapresso:</i> The highest pressure to be assumed after the absorption of the drinking water to be stored.
psv	Response pressure safety valve According to EN ISO 4126-0 the pressure at which the safety valve at the heat generator begins to open.
psv_c	Closing pressure tolerance Difference between response pressure and closing pressure for safety valves EN ISO 4126-1.
psv_o	Opening pressure tolerance Difference between response pressure and opening pressure for safety valves EN ISO 4126-1.
PS	Maximum admissible pressure According to the pressure device directive the maximum pressure for which the pressure device has been dimensioned according to the manufacturer's specification.
PS_{CH}	Maximum admissible pressure Switzerland Pressure up to which the expansion vessel does not require an approval according to the Swiss directive SWKI HE301-01 ($PS \cdot VN \leq 3000 \text{ bar} \cdot \text{litre}$).
PF	Pressure factor Ratio between the required nominal volume VN and the water absorption volume Ve + Vwr for expansion vessels.
pw	Fresh water pressure Flow pressure of the fresh water network, e.g. drinking water network, that is available before the water make-up device.
dpu	Working pressure range Pressure range for which a water make-up or degassing device has been designed. It must be adjusted to the working pressure of the system.
dpqN	Pressure loss with nominal flow Pressure loss referred to the nominal flow capacity of a device, e.g. Aquapresso or Zeparo.

Volumes

e	Expansion coefficient According to EN 12828 the factor for the calculation of the expansion volume from the water capacity. In this case, referred to the solidification point.
ehs	Expansion coefficient of storage tanks The factor for the calculation of the expansion volume from the water capacity of heating/cooling storage tanks
Vs	Overall system water capacity According to EN 12828 the overall water capacity of the heating system that is involved in the volume expansion.
vs	Specific overall system water capacity Overall water capacity of the heating system that is involved in the volume expansion, referred to the installed heating surface output.
Vhs	Water content of storage tanks Total water content of heat and cooling storage tanks involved in the volume expansion.
VN	Nominal volume According to the pressure device directive the entire internal volume of the pressure compartment of the expansion vessel.
VNd	Water capacity for which a device is rated Characteristic performance parameter that describes up to which water capacity the device, e.g. Vento, can be used.
Vsolar	Water content collector panels For solar systems to ENV 12977-1 the collector volume which can phase change to steam has to be added to the connecting pipes volume.
Ve	Expansion volume According to EN 12828 the volume expansion of the water capacity of the heating system between the min. and max. system temperature.
Vwr	Water reserve According to EN 12828 the water quantity in the expansion vessel for the compensation of water losses caused by the system.

Temperatures

ts_{max}	Maximum system temperature Maximum temperature for the calculation of the volume expansion. For heating systems the dimensioned flow temperature at which a heating system is to be operated with the lowest outside temperature to be assumed (standard outside temperature according to EN 12828). For cooling systems the max. temperature that is achieved due to the operation mode or standstill, for solar systems the temperature up to which an evaporation is to be avoided.
ts_{min}	Lowest system temperature Lowest temperature for calculating expansion volumes. The lowest system temperature is equal to the freezing point. It is dependant on the percentage of antifreeze additives. For water without additives $ts_{min} = 0$.
t_{pr}	Primary flow temperature Maximum flow temperature in primary circuit of heat exchangers (indirect fired).
t_r	Return temperature Return temperature of the heating system with the lowest outside temperature to be assumed (standard outside temperature according to EN 12828).
TV	Maximum flow temperature Maximum flow temperature for which a device is equipped according to the normative and safetyrelated requirements. TV may be greater than TS if the device is installed at a place with $t \leq TS$, e.g. in the system return.
TAZ	Safety temperature limiter Safety temperature controller Temperature limit Safety device according to EN 12828 for the temperature protection of heat generators. If the set temperature limit is exceeded the heating is turned off. Limiters are locked, controllers automatically release the heat supply if the set temperature falls short. Setting value for systems according to EN 12828 ≤ 110 °C.
TS	Maximum admissible temperature According to the pressure device directive the maximum temperature for which the pressure device or the fixture has been dimensioned according to the manufacturer's specification.
TS_{min}	Minimum admissible temperature According to the pressure device directive the minimum temperature for which the pressure device or the fixture has been dimensioned according to the manufacturer's specification.
TWM	Maximum admissible temperature for water make up The highest admissible temperature for make up units as part of a pressurisation or degassing system. This only applies if TWM < TS.
TB	Maximum admissible bag temperature Maximum admissible permanent temperature for the butyl bag.
TB_{min}	Minimum admissible bag temperature Minimum admissible permanent temperature for the butyl bag.
TA	Maximum admissible ambient temperature Maximum ambient temperature for the installation of a device.

Capacities

Q	Heat capacity Blowing-off capacity of a safety valve referred to the vapour emission according to the component inspection.
QNsv	Heat capacity Blow off capacity of a safety valve referred to the vapour emission according to the component inspection.
QNsv_w	Heat capacity Blow off capacity of a safety valve for water flow according to specification, related the to heat output of the heat generator, 1 kW = 1 l/h.
qN	Flow rate, Nominal flow Nominal throughput of a device, e.g. Aquapresso, Zeparo or nominal flow rate of a compressor or pump.
qN_{max}	Maximum flow Maximum throughput of a device, e.g. Zeparo.
Kvs	Flow parameter Throughput of a device with a differential pressure of 1 bar.
qNwm	Water make-up capacity Nominal capacity of a water make-up device.
U	Voltage Nominal voltage for an electric device.
I	Electric current Admissible current load for a device.
Pel	Electric load Load for an electric device.
SPL	Sound pressure level Sound pressure level dB(A) – effective perceived.
IP	Code for protection against moisture and physical contact according to EN 60529.

Additional information

System design: calculation software HySelect