

V5032 KOMBI-2-PLUS MANUAL DOUBLE REGULATING BALANCING VALVE

- The V5032 Kombi-2-plus is a static, variable orifice double-regulating balancing valve for the return with additional shutoff function.
 - It is suitable for use in variable and constant flow systems to manually balance the flow and to set resistances to an equal level all over the system.
 - V5032 Kombi-2-plus is typically used for static balancing of fan coil units, air handling units, chilled ceilings and two-pipe heating systems. A usage in the return is to be preferred but it can be used also in the supply.
- Wide range of application
 - Sizes DN15 up to DN80
 - Versions for standard and low flow rates available
- Easy commissioning
 - Fast and safe measurement with SafeCon™ measuring connections – 6 times faster than standard Binder connections
 - DN size and settings readable on handwheel even with insulated valve
 - All functions located on one side for easier access and use
 - Optimal measuring in combination with Honeywell BasicMess (VM242) – all flow values are already included in the measuring device
- Maintenance friendly
 - Insert fully interchangeable
 - Integrated shutoff function
 - Pre-setting is not changed during shutoff

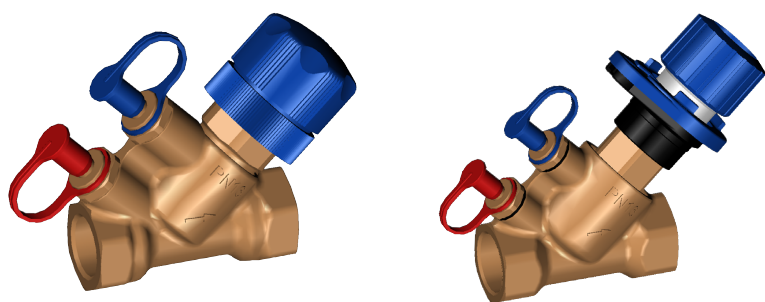

APPLICATION

The V5032 Kombi-2-plus is a static, variable orifice double-regulating balancing valve for the return with additional shutoff function.

It is suitable for use in variable and constant flow systems to manually balance the flow and to set resistances to an equal level all over the system.

V5032 Kombi-2-plus is typically used for static balancing of fan coil units, air handling units, chilled ceilings and two-pipe heating systems. A usage in the return is to be preferred but it can be used also in the supply..

Valve Efficiency	low				high
Energy efficiency	●	●	●	○	○
Commissioning Effort	●	●	●	●	●
Calculation effort	●	●	●	●	○

Technical Specification

OS-No.	V5032...BLF	V5032...B	
Nominal size	DN15	DN15 – DN50	DN65 – DN80
Housing	Dezincification resistant brass	Dezincification resistant brass	Red bronze
Medium	Water or water-glycol mixture, quality to VDI 2035 (up to 50% Glycol)		
pH-value	8...9,5		
Operating temperature	>-20...130°C (-4...266°F)*		
kvs (cvs)-value	see table on page 4		
Operating pressure (PN)	max. 16 bar (232 psi)		

* for water-glycol mixtures - max temperature 110°C

Construction

The V5032...BLF Kombi-2-plus (DN15) consists of

- Valve housing with internal threads to DIN EN 10226-1 for threaded pipe and two G1/4" connections equipped with SafeCon™ pressure test valves
- Handwheel for the shut-off function
- Pre-setting and display
- Two SafeCon™ measuring connections
- Installation and setup instructions

The V5032...B Kombi-2-plus (DN15 - DN50) consists of

- Valve housing with internal threads to DIN EN 10226-1 for threaded pipe and two G1/4" connections equipped with SafeCon™ pressure test valves
- Valve insert with shutoff function
- Handwheel with pre-setting dial and display
- Two SafeCon™ measuring connections
- Installation and setup instructions

The V5032...B Kombi-2-plus (DN65 - DN80) consists of

- Valve housing with internal threads to DIN EN 10226-1 for threaded pipe and two G1/4" connections equipped with SafeCon™ pressure test valves
- Valve insert with shutoff function
- Handwheel with pre-setting dial and display
- Two SafeCon™ measuring connections
- Installation and setup instructions

Materials

V5032...BLF Kombi-2-plus (DN15)

- Valve housing made of dezincification resistant brass
- Valve insert made of brass with EPDM O-rings and soft seals
- O-rings and soft sealings made of EPDM
- Handwheel made of plastic

V5032...B Kombi-2-plus (DN15 - DN50)

- Valve housing made of dezincification resistant brass
- Valve insert made of brass with seat sealing made of PTFE
- O-rings and soft sealings made of EPDM
- Handwheel, pre-setting dial and display made of plastic

V5032...B Kombi-2-plus (DN65 - DN80)

- Valve housing made of red bronze
- Valve insert made of brass with seat sealing made of PTFE
- O-rings and soft sealings made of EPDM
- Handwheel made of steel

Method of Operation

The V5032 valves are usually installed in the return pipeline. Based on the required flow rate the valve is pre-set to a certain value by turning the pre-setting clockwise (increasing the pre-setting) or anticlockwise (decreasing the pre-setting). Required pre-setting value can be determined by using tables further below, by using a sizing tool, by measuring or directly from design documentation. The required flow at full load is normally calculated in advance by a consultant or similar specialist and must be known for system balancing.

Please note:

- To avoid stone deposit and corrosion the composition of the medium should conform with VDI-Guideline 2035
- Additives have to be suitable for EPDM sealings
- System has to be flushed thoroughly before initial operation with all valves fully open
- Any complaints or costs resulting from non-compliance with above rules will not be accepted by Honeywell
- Please contact us if you should have any special requirements or needs

Valve Identification

Each valve is marked as follows:

- OS-Number
- DN size
- PN rating
- Flow arrows
- Serial number/date code

Overview

V5032...BLF Kombi-2-plus Low Flow (DN15)

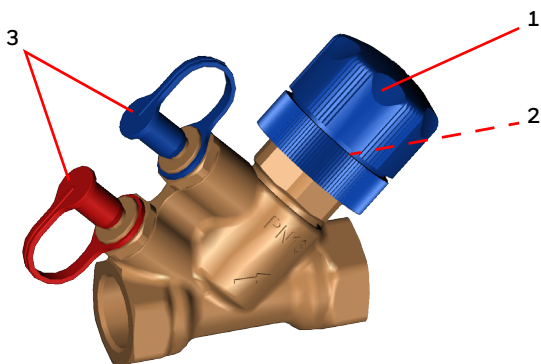

1. Handwheel for the shutoff function
2. Concealed pre-setting with numeric display
3. SafeCon™ pressure test valve with color marked protection cap

V5032...B Kombi-2-plus (DN15 - DN80)

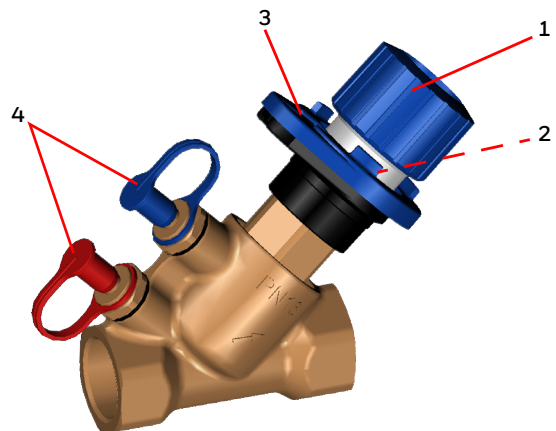

1. Handwheel for the shutoff function
2. Concealed pre-setting
3. Numeric display of pre-setting
4. SafeCon™ pressure test valve with color marked protection cap

Dimensions

V5032...BLF Kombi-2-plus (DN15)

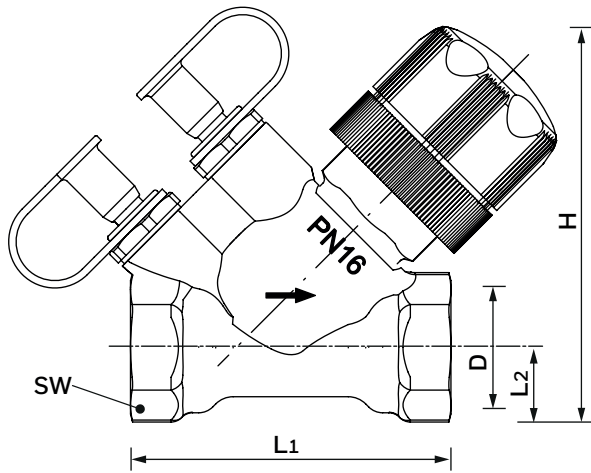

DN	D	H	L1	L2	SW
15	Rp1/2"	82	65	15	27

V5032...B Kombi-2-plus (DN15 - DN50)

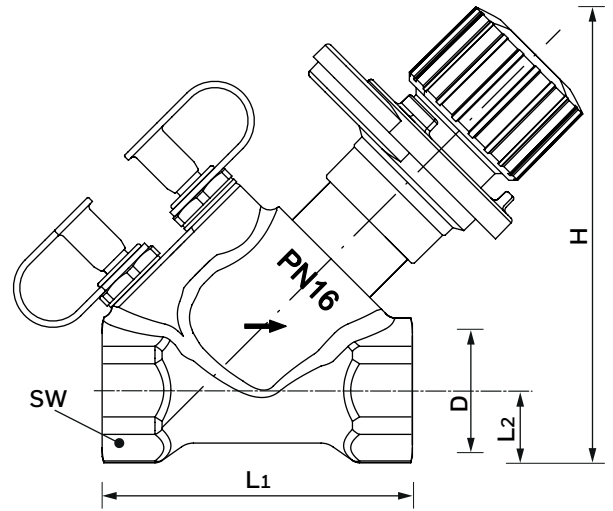

DN	D	H	L1	L2	SW
15	Rp1/2"	101	65	15	27
20	Rp3/4"	116	75	18	32
25	Rp1"	121	90	22	41
32	Rp1 1/4"	160	110	27	50
40	Rp1 1/2"	164	120	30	55
50	Rp2"	192	150	38	70

V5032...B Kombi-2-plus (DN65 - DN80)

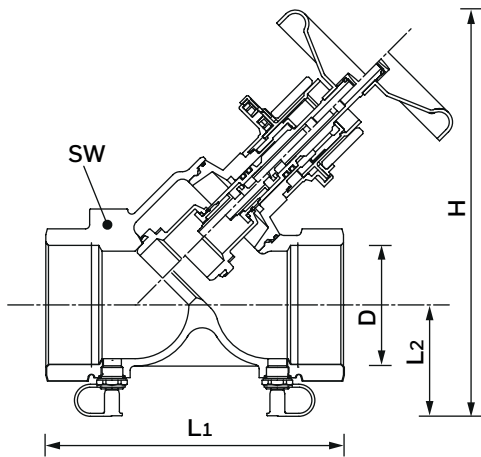

DN	D	H	L1	L2	SW
65	Rp2 1/2"	195	180	68	85
80	Rp3"	210	200	73	100

NOTE: All dimensions in mm unless stated otherwise. NOTE: Dimension 'H' refers to fully open valve.

Ordering Information

Available versions and OS-Nos (OS=Ordering Specification)

DN size	kvs(cvs)-value	Weight [g]	OS-No.
DN15 BLF	0.43 (0.5)	350	V5032Y0015BLF
DN15	2.6 (3.0)	425	V5032Y0015B
DN20	6.5 (7.5)	560	V5032Y0020B
DN25	6.6 (7.6)	720	V5032Y0025B
DN32	21.9 (25.3)	1230	V5032Y0032B
DN40	21.2 (24.5)	1320	V5032Y0040B
DN50	41.5 (48.0)	2380	V5032Y0050B
DN65	45.3 (52.6)	2300	V5032Y0065B
DN80	73.0 (84.9)	2300	V5032Y0080B

Accessories

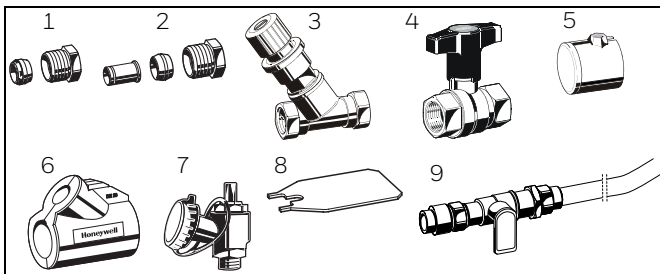

No.	Description	Dimension	Part No.	Pcs/pack
-----	-------------	-----------	----------	----------

1	Compression fitting for COPPER and STEEL pipe. Consisting of compression nut and compression ring. For valves with internal thread.			
	1/2" (DN15)	10 mm	FIG1/2CS10	1
	1/2" (DN15)	12 mm	FIG1/2CS12	1
	1/2" (DN15)	14 mm	FIG1/2CS14	1
	1/2" (DN15)	15 mm	FIG1/2CS15	1
	1/2" (DN15)	15 mm	FIG1/2CS15-10	10
	1/2" (DN15)	16 mm	FIG1/2CS16	1
	3/4" (DN20)	18 mm	FIG3/4CS18	1
	3/4" (DN20)	22 mm	FIG3/4CS22	1
NOTE: Support inserts have to be used for copper or soft steel pipe with 1.0 mm wall thickness. Max. operating temperature 120°C, max. operating pressure 10 bar.				

No.	Description	Dimension	Part No.	Pcs/pack
-----	-------------	-----------	----------	----------

2	Compression fitting for COPPER and SOFT STEEL pipe. Consisting of compression nut, compression ring and support insert. For valves with internal thread.			
	1/2" (DN15)	12 mm	FIG1/2CSS12	1
	1/2" (DN15)	14 mm	FIG1/2CSS14	1
	1/2" (DN15)	15 mm	FIG1/2CSS15	1
	1/2" (DN15)	16 mm	FIG1/2CSS16	1
	1/2" (DN15)	18 mm	FIG1/2CSS18	1
	3/4" (DN20)	18 mm	FIG3/4CSS18	1

NOTE: Support inserts have to be used for copper or soft steel pipe with 1.0 mm wall thickness. Max. operating temperature 120°C, max. operating pressure 10 bar.

No.	Description	Part No.
-----	-------------	----------

3	Kombi-3-plus RED (V5000) measuring and shutoff valve for the supply	
	1/2" (for DN 15)	V5000Y0015
	3/4" (for DN 20)	V5000Y0020
	1" (for DN 25)	V5000Y0025
	1 1/4" (for DN 32)	V5000Y0032
	1 1/2" (for DN 40)	V5000Y0040
	2" (for DN 50)	V5000Y0050
	2 1/2" (for DN 65)	V5000Y0065
	3" (for DN 80)	V5000Y0080

NOTE: For product information and diagrams see product data sheet 'V5000 Kombi-3-plus'

No.	Description	Part No.
5	Tamper-proof cap	
	for valves DN15...DN25	VA2501A010
	for valves DN32...DN50	VA2501A032
6	Insulation shells	
	for valves DN15	VA2510D015
	for valves DN20	VA2510D020
	for valves DN25	VA2510D025
	for valves DN32	VA2510D032
	for valves DN40	VA2510D040
for valves DN50	VA2510D050	
7	Draining valve	
	for all types and sizes	VA3401A008
8	Pre-setting key	
	for Kombi-II-plus V5032...BLF valves DN15	VS1200FV01
9	Draining adapter for SafeCon™ Connection	
	for all dimensions	VA5032A001

Measuring Equipment



No.	Description	Part No.
1	Measuring adapter (2pcs.)	
	For measuring with old measuring computer VM242	VA3600C001
2	VM242A BasicMes-2 handheld measuring computer	
	For all sizes. Computer is supplied with case and accessories	VM242A0101
NOTE: To connect the VM242 BasicMes-2 to SafeCon™ pressure test cocks please order measuring adapter VA3600C001 separately.		

Spare Parts

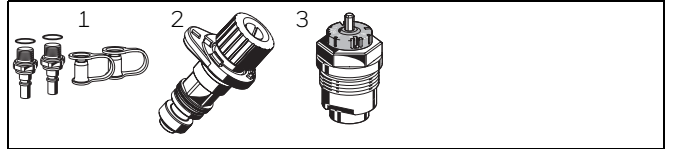

No.	Description	Part No.
1	Spare set of 2 pressure test cocks G1/4"	
	for all dimensions	VS2600C001
2	Valve insert for Kombi-II-plus V5032...B	
	for valves DN15	VS5032DZ1015
	for valves DN20	VS5032DZ1020
	for valves DN25	VS5032DZ1025
	for valves DN32	VS5032DZ1032
	for valves DN40	VS5032DZ1040
for valves DN50	VS5032DZ1050	
3	Valve insert	
	for Kombi-II-plus V5032...BLF valves DN15	VS1200FV01

Flow Data V5032...BLF (DN15)

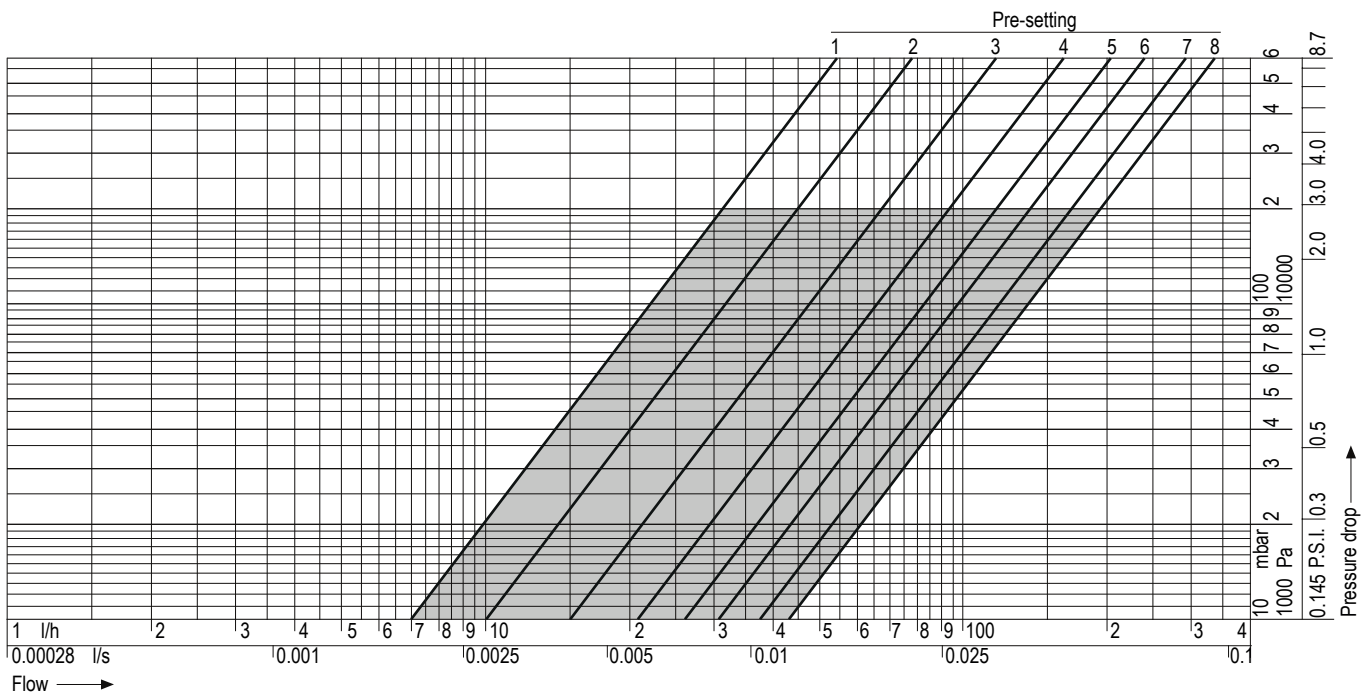

■ Recommended range of application when used with an actuator.

Pre-setting values

Setting	1	2	3	4	5	6	7	8
k_v-value	0.07	0.10	0.15	0.21	0.26	0.31	0.37	0.43
cv-value	0.06	0.09	0.13	0.18	0.22	0.27	0.32	0.37

Flow Data V5032...B (DN15)

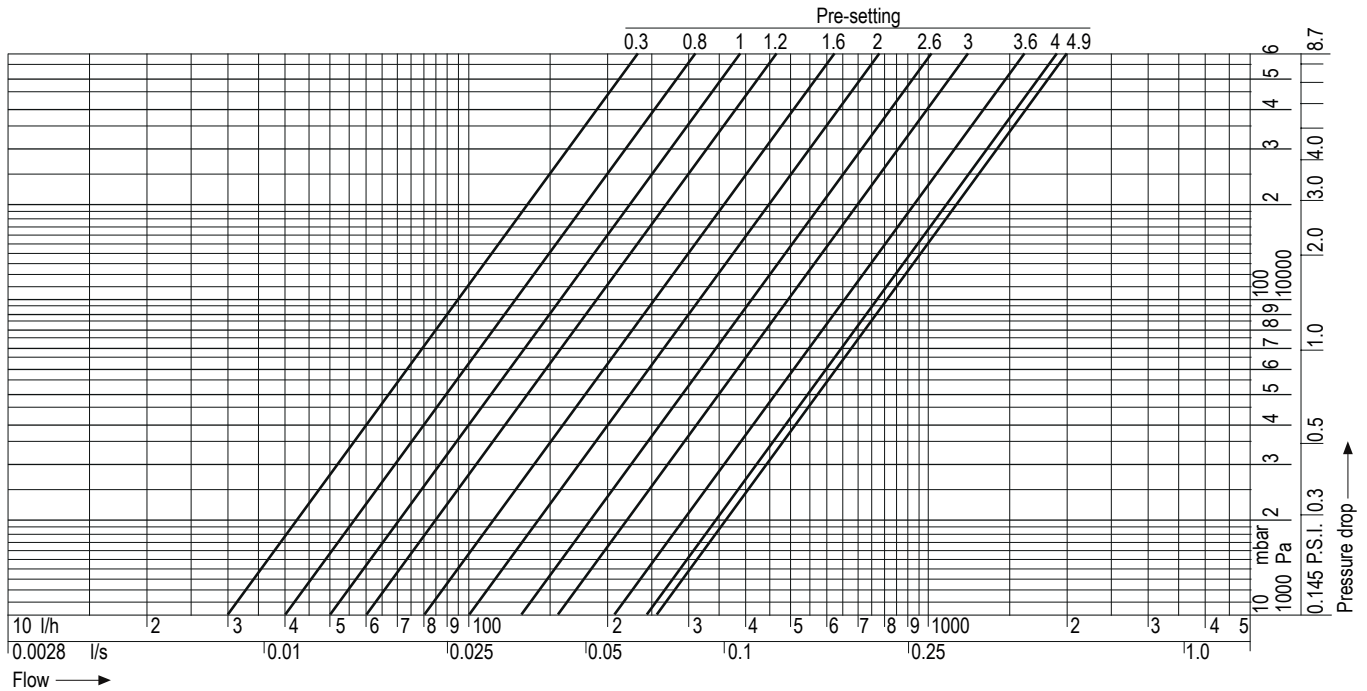

Pre-setting values

Setting	0.3	0.4	0.6	0.8	1.0	1.2	1.4	1.6	1.8	2.0	2.2	2.4	2.6	2.8	3.0	3.2	3.4	3.6
k_v-value	0.3	0.3	0.3	0.4	0.5	0.6	0.7	0.8	0.9	1.0	1.1	1.2	1.3	1.5	1.6	1.8	2.0	2.1
c_v-value	0.3	0.3	0.3	0.5	0.6	0.7	0.8	0.9	1.0	1.2	1.3	1.4	1.5	1.7	1.9	2.1	2.3	2.4

Setting	3.8	4.0	4.2	4.4	4.6	4.8	4.9 = open
k_v-value	2.3	2.4	2.4	2.5	2.5	2.6	k _{vS} = 2.6
c_v-value	2.7	2.8	2.8	2.9	2.9	3.0	c _{vS} = 3.0

Flow Data V5032...B (DN20)

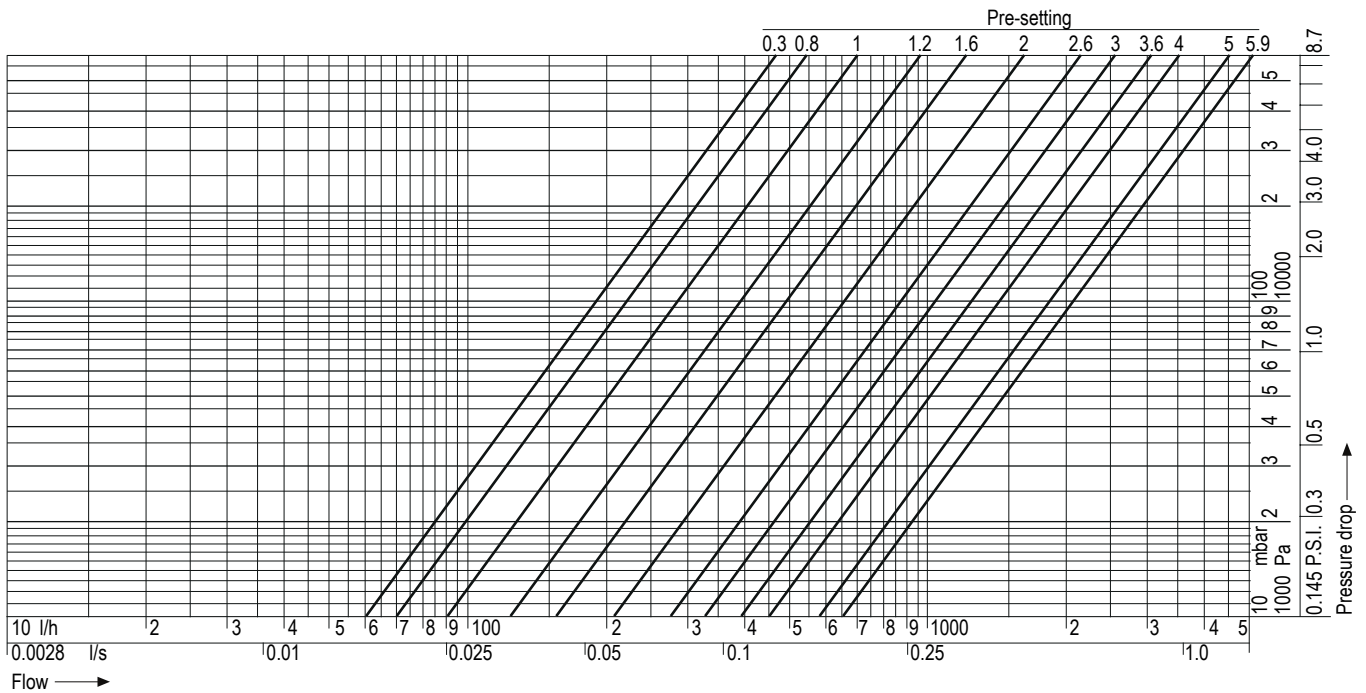

Pre-setting values

Setting	0.3	0.4	0.6	0.8	1.0	1.2	1.4	1.6	1.8	2.0	2.2	2.4	2.6	2.8	3.0	3.2	3.4	3.6
kv-value	0.6	0.6	0.6	0.7	0.9	1.2	1.4	1.6	1.8	2.1	2.3	2.5	2.7	3.0	3.2	3.4	3.7	3.9
cv-value	0.7	0.7	0.7	0.8	1.1	1.4	1.6	1.9	2.1	2.4	2.6	2.9	3.2	3.4	3.7	4.0	4.2	4.6

Setting	3.8	4.0	4.2	4.4	4.6	4.8	5.0	5.2	5.4	5.6	5.8	5.9 = open
kv-value	4.2	4.5	4.8	5.1	5.3	5.5	5.7	5.9	6.1	6.3	6.5	kvs = 6.5
cv-value	4.9	5.3	5.6	5.9	6.2	6.4	6.7	6.9	7.1	7.3	7.5	cvs = 7.6

Flow Data V5032...B (DN25)

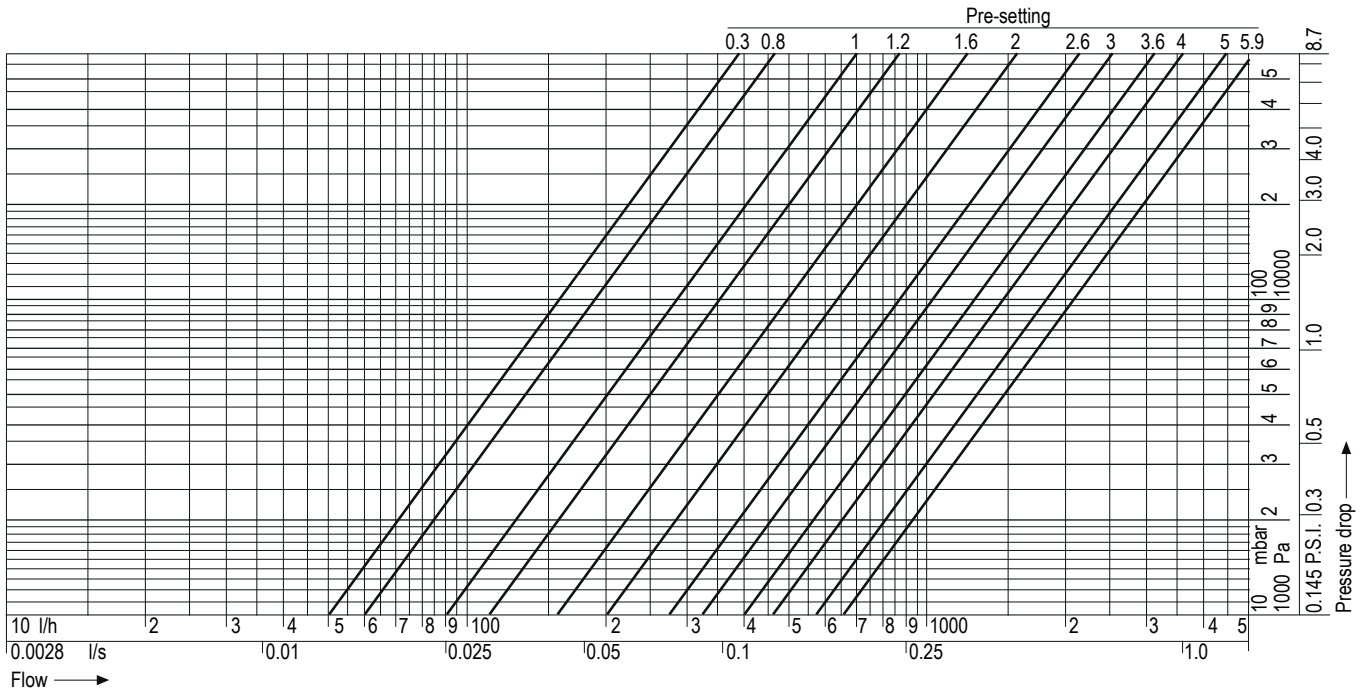

Pre-setting values

Setting	0.3	0.4	0.6	0.8	1.0	1.2	1.4	1.6	1.8	2.0	2.2	2.4	2.6	2.8	3.0	3.2	3.4	3.6
kv-value	0.5	0.5	0.5	0.6	0.9	1.1	1.3	1.6	1.8	2.0	2.2	2.5	2.7	3.0	3.2	3.4	3.7	4.0
cv-value	0.6	0.6	0.6	0.7	1.0	1.3	1.5	1.8	2.1	2.3	2.6	2.9	3.1	3.4	3.7	4.0	4.3	4.6

Setting	3.8	4.0	4.2	4.4	4.6	4.8	5.0	5.2	5.4	5.6	5.8	5.9 = open
kv-value	4.3	4.6	4.9	5.2	5.4	5.5	5.7	5.8	6.0	6.2	6.5	kvs = 6.6
cv-value	5.0	5.4	5.7	6.0	6.3	6.4	6.6	6.8	6.9	7.2	7.5	cvs = 7.6

Flow Data V5032...B (DN32)

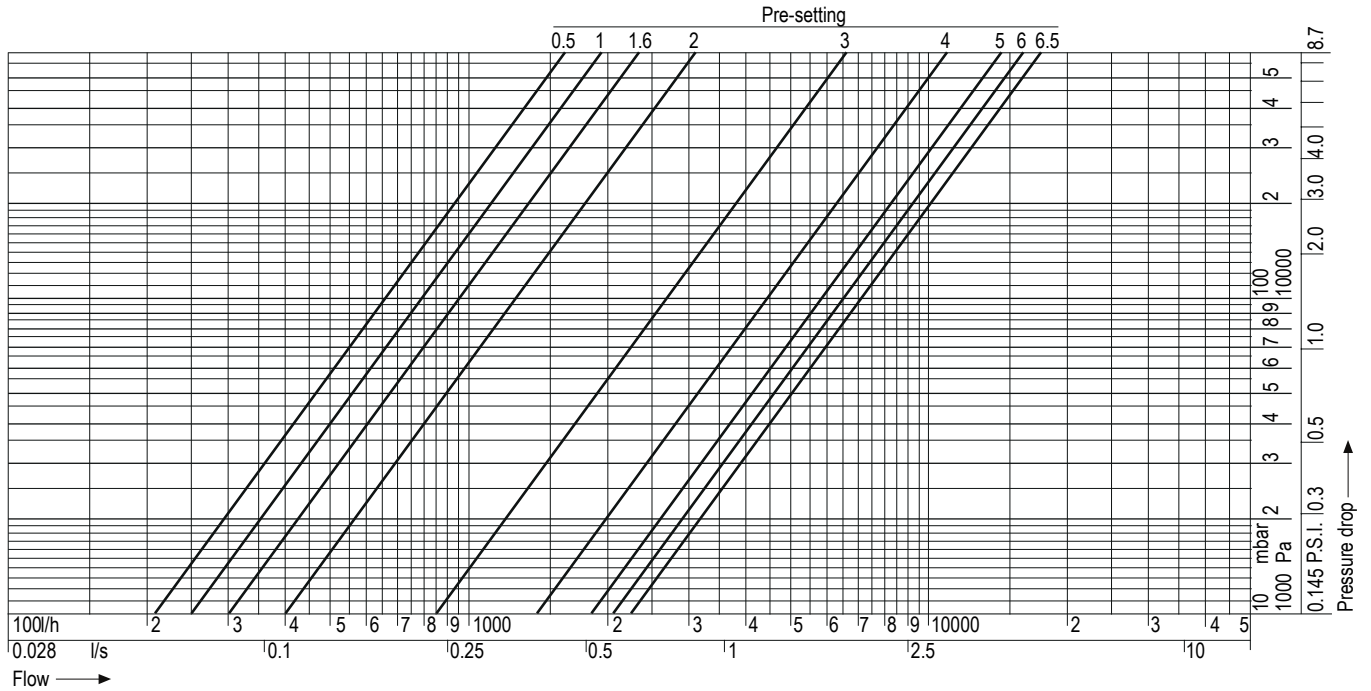

Pre-setting values

Setting	0.5	1.0	1.2	1.4	1.5	1.6	1.8	2.0	2.2	2.4	2.6	2.8	3.0	3.2	3.4	3.6
k_V -value	2.1	2.5	2.7	2.8	2.9	3.0	3.4	4.0	4.8	5.7	6.6	7.5	8.5	9.6	10.9	12.0
cv-value	2.5	2.9	3.1	3.3	3.4	3.5	4.0	4.6	5.6	6.6	7.6	8.7	9.9	11.2	12.7	14.0

Setting	3.8	4.0	4.2	4.4	4.6	4.8	5.0	5.2	5.4	5.6	5.8	6.0	6.2	6.4	6.5 = open
k_V -value	13.1	14.1	15.3	16.3	17.2	17.9	18.5	19.1	19.4	19.7	20.0	20.5	21.0	21.6	$k_{VS} = 21.9$
cv-value	15.2	16.5	17.8	19.0	20.0	20.8	21.5	22.2	22.6	22.9	23.3	23.9	24.4	25.1	$c_{VS} = 25.5$

Flow Data V5032...B (DN40)

Flow Data V5032...B (DN40)

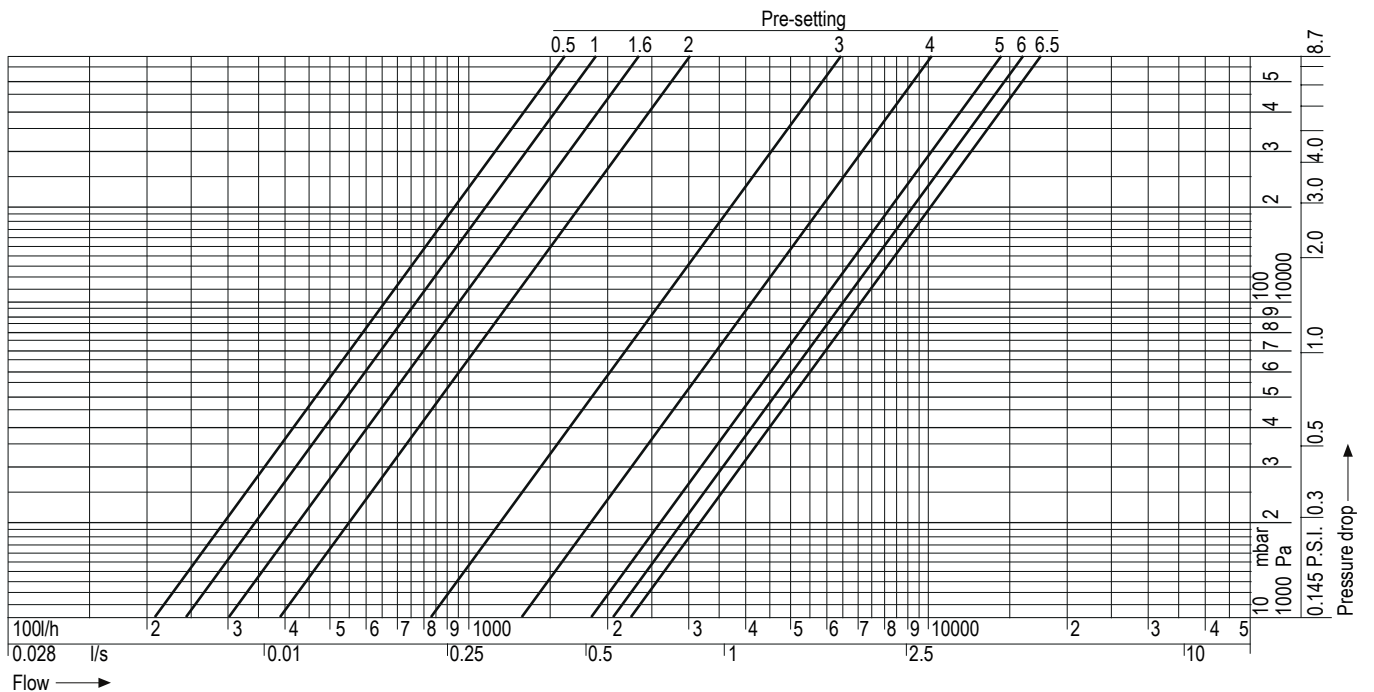

Pre-setting values

Setting	0.5	1.0	1.2	1.4	1.5	1.6	1.8	2.0	2.2	2.4	2.6	2.8	3.0	3.2	3.4	3.6
kv-value	2.1	2.4	2.6	2.8	2.9	3.0	3.3	3.9	4.6	5.4	6.3	7.3	8.3	9.3	10.4	11.5
cv-value	2.4	2.8	3.0	3.3	3.4	3.5	3.9	4.5	5.4	6.3	7.3	8.5	9.6	10.9	12.1	13.3

Setting	3.8	4.0	4.2	4.4	4.6	4.8	5.0	5.2	5.4	5.6	5.8	6.0	6.2	6.4	6.5 = open
kv-value	12.6	13.7	14.8	15.9	16.8	17.5	18.2	18.6	18.9	19.1	19.6	20.1	20.6	21.1	kv _s = 21.2
cv-value	14.6	16.0	17.2	18.5	19.5	20.3	21.1	21.6	22.0	22.2	22.8	23.4	23.9	24.5	cv _s = 24.6

Flow Data V5032...B (DN65)

Flow Data V5032...B (DN65)

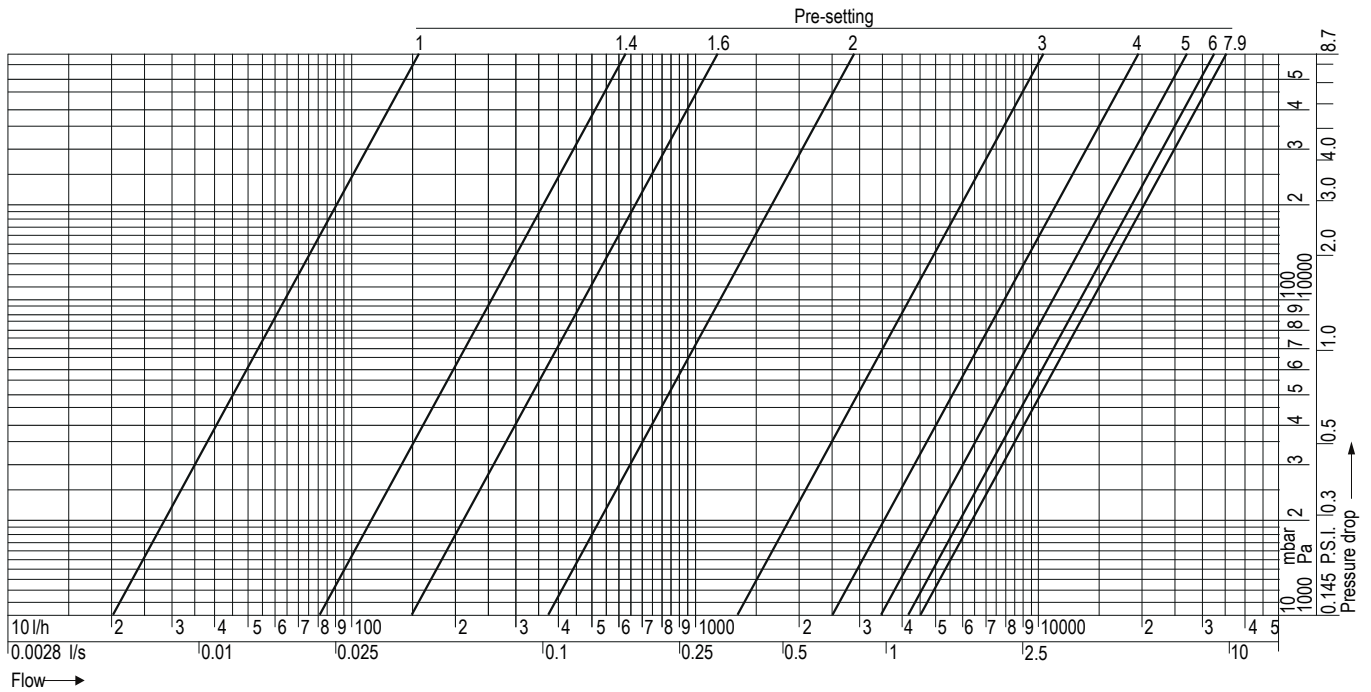

Pre-setting values

Setting	1.0	1.2	1.4	1.6	1.8	2.0	2.2	2.4	2.6	2.8	3.0	3.2	3.4	3.6	3.8	4.0	4.2	4.4
kv-value	0.2	0.2	0.8	1.5	2.5	3.7	5.2	7.0	9.0	11.1	13.4	15.8	18.1	20.5	22.9	25.1	27.3	29.3
cv-value	0.3	0.2	0.9	1.8	2.9	4.4	6.1	8.1	10.4	12.9	15.6	18.3	21.1	23.9	26.6	29.2	31.7	34.1

Setting	4.6	4.8	5.0	5.2	5.4	5.6	5.8	6.0	6.2	6.4	6.6	6.8	7.0	7.2	7.4	7.6	7.9 = open
kv-value	31.3	33.1	34.8	36.4	37.9	39.2	40.4	41.4	42.3	43.0	43.6	44.0	44.4	44.7	44.9	45.1	kv _s = 45.3
cv-value	36.4	38.5	40.5	42.4	44.1	45.6	46.9	48.1	49.1	50.0	50.7	51.2	51.7	52.0	52.2	52.4	cv _s = 52.6

Flow Data V5032...B (DN80)

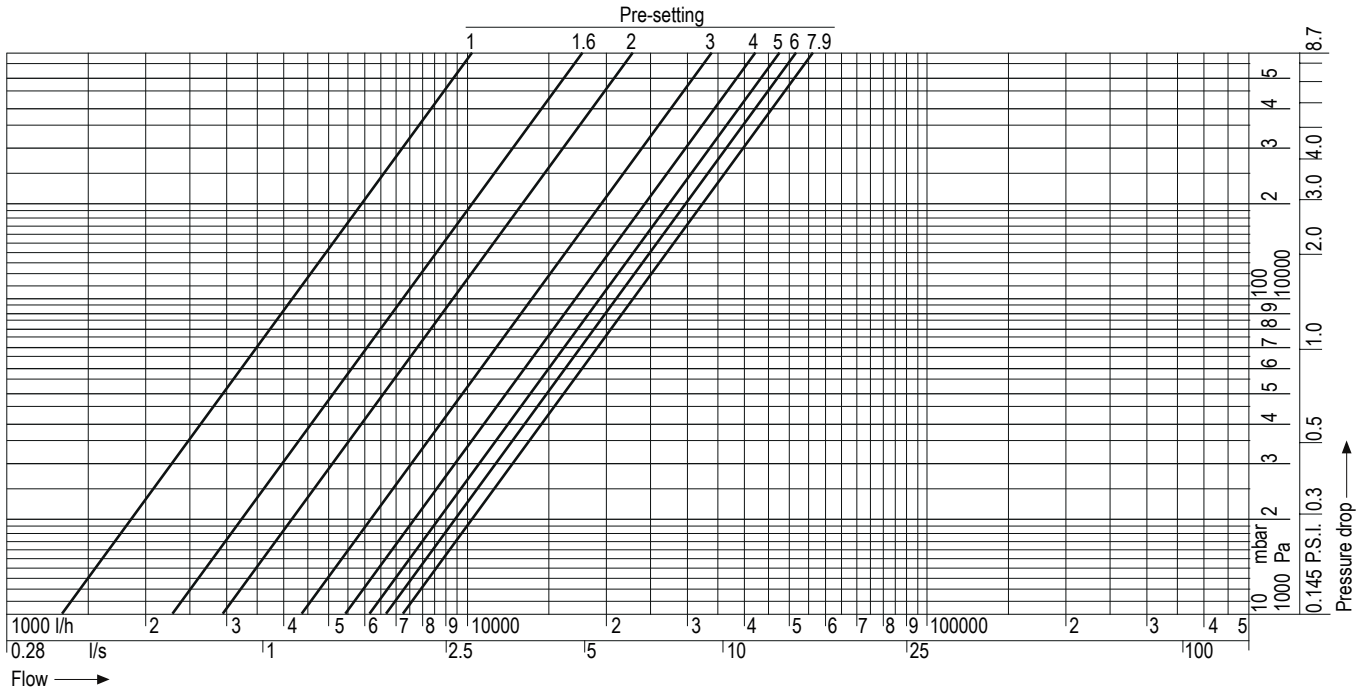

Pre-setting values

Setting	1.0	1.2	1.4	1.6	1.8	2.0	2.2	2.4	2.6	2.8	3.0	3.2	3.4	3.6	3.8	4.0	4.2	4.4
k_v -value	13.9	16.9	20.0	23.1	26.2	29.3	32.3	35.3	38.1	40.8	43.4	45.9	48.2	50.4	52.4	54.3	56.0	57.6
c_v -value	16.2	19.7	23.2	26.8	30.4	34.0	37.6	41.0	44.3	47.5	50.5	53.4	56.1	58.6	60.9	63.1	65.1	67.0

Setting	4.6	4.8	5.0	5.2	5.4	5.6	5.8	6.0	6.2	6.4	6.6	6.8	7.0	7.2	7.4	7.6	7.9 = open
k_v -value	59.1	60.5	61.8	62.9	64.0	65.0	65.9	66.8	67.6	68.3	69.0	69.7	70.3	71.0	71.6	72.1	$k_{vS} = 73.0$
c_v -value	68.7	70.4	71.8	73.2	74.4	75.6	76.7	77.7	78.6	79.5	80.3	81.1	81.8	82.5	83.2	83.9	$c_{vS} = 84.9$

Flow Data V5032...B (DN50)

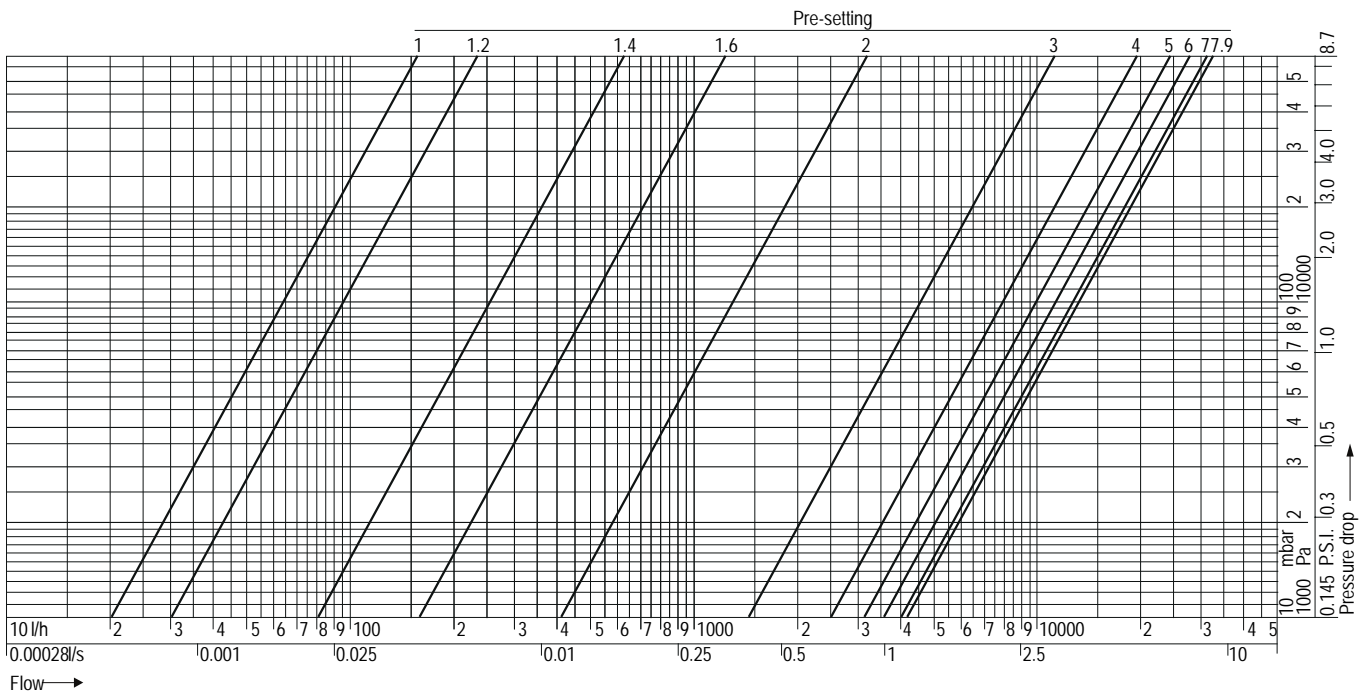

Pre-setting values

Setting	1.0	1.2	1.4	1.6	1.8	2.0	2.2	2.4	2.6	2.8	3.0	3.2	3.4	3.6	3.8	4.0	4.2	4.4
kv-value	0.2	0.3	0.8	1.6	2.7	4.1	5.7	7.6	9.6	11.9	14.2	16.6	19.2	21.5	23.7	25.5	26.6	27.7
cv-value	0.2	0.3	0.9	1.9	3.2	4.8	6.7	8.8	11.2	13.8	16.5	19.3	22.3	25.0	27.6	29.7	30.9	32.2

Setting	4.6	4.8	5.0	5.2	5.4	5.6	5.8	6.0	6.2	6.4	6.6	6.8	7.0	7.2	7.4	7.6	7.9 = open
kv-value	28.9	29.9	31.0	32.1	32.8	34.0	34.9	36.0	36.9	37.9	38.8	39.7	40.6	41.0	41.5	41.6	k _{VS} = 41.5
cv-value	33.6	34.8	36.1	37.3	38.2	39.5	40.6	41.8	42.9	44.1	45.1	46.1	47.2	47.7	48.3	48.4	c _{VS} = 48.3

kv-values for measuring with NON-Honeywell devices

V5032...BLF (DN15)

Setting	1	2	3	4	5	6	7	8
kv-value	0.07	0.10	0.15	0.21	0.26	0.31	0.37	0.43
cv-value	0.06	0.09	0.13	0.18	0.22	0.27	0.32	0.37

V5032...B (DN15)

Setting	0.3	0.4	0.6	0.8	1.0	1.2	1.4	1.6	1.8	2.0	2.2	2.4	2.6	2.8	3.0	3.2	3.4	3.6
kv-value	0.3	0.3	0.3	0.4	0.5	0.6	0.7	0.8	1.0	1.1	1.2	1.4	1.5	1.7	1.9	2.1	2.4	2.7
cv-value	0.3	0.3	0.3	0.5	0.6	0.7	0.8	0.9	1.2	1.3	1.4	1.6	1.7	2.0	2.2	2.4	2.8	3.1

Setting	3.8	4.0	4.2	4.4	4.6	4.8	4.9 = open
kv-value	2.9	3.2	3.4	3.6	3.8	4.1	k _{VS} = 4.3
cv-value	3.4	3.7	4.0	4.2	4.4	4.8	c _{VS} = 5.0

V5032...B (DN20)

Setting	0.3	0.4	0.6	0.8	1.0	1.2	1.4	1.6	1.8	2.0	2.2	2.4	2.6	2.8	3.0	3.2	3.4	3.6
kv-value	0.6	0.6	0.6	0.7	1.0	1.2	1.5	1.7	2.0	2.3	2.5	2.8	3.1	3.3	3.6	3.8	4.1	4.4
cv-value	0.7	0.7	0.7	0.9	1.1	1.4	1.7	2.0	2.3	2.6	2.9	3.2	3.6	3.9	4.2	4.4	4.7	5.1

Setting	3.8	4.0	4.2	4.4	4.6	4.8	5.0	5.2	5.4	5.6	5.8	5.9 = open
kv-value	4.8	5.2	5.6	5.9	6.3	6.6	6.9	7.2	7.6	7.9	8.2	k _{VS} = 8.4
cv-value	5.6	6.1	6.5	6.9	7.4	7.7	8.0	8.4	8.8	9.2	9.6	c _{VS} = 9.8

V5032...B (DN25)

Setting	0.3	0.4	0.6	0.8	1.0	1.2	1.4	1.6	1.8	2.0	2.2	2.4	2.6	2.8	3.0	3.2	3.4	3.6
kv-value	0.5	0.6	0.6	0.6	0.9	1.1	1.4	1.7	1.9	2.2	2.4	2.7	2.9	3.2	3.5	3.7	3.9	4.2
cv-value	0.6	0.8	0.8	0.8	1.1	1.3	1.6	1.9	2.2	2.5	2.8	3.1	3.4	3.7	4.0	4.3	4.5	4.9

Setting	3.8	4.0	4.2	4.4	4.6	4.8	5.0	5.2	5.4	5.6	5.8	5.9 = open
kv-value	4.4	4.7	5.1	5.5	5.8	6.0	6.2	6.4	6.5	6.8	7.3	k _{VS} = 7.4
cv-value	5.1	5.5	6.0	6.4	6.8	7.0	7.2	7.4	7.5	7.9	8.4	c _{VS} = 8.6

V5032...B (DN32)

Setting	0.5	1.0	1.2	1.4	1.5	1.6	1.8	2.0	2.2	2.4	2.6	2.8	3.0	3.2	3.4	3.6
kv-value	2.1	2.5	2.7	2.9	3.0	3.1	3.4	4.1	4.9	5.8	6.7	7.6	8.7	9.9	11.4	13.2
cv-value	2.5	2.9	3.1	3.4	3.5	3.6	4.0	4.8	5.7	6.7	7.8	8.9	10.1	11.5	13.3	15.3

Setting	3.8	4.0	4.2	4.4	4.6	4.8	5.0	5.2	5.4	5.6	5.8	6.0	6.2	6.4	6.5 = open
kv-value	15.2	17.3	19.4	21.3	22.5	23.1	22.6	22.0	21.1	21.0	20.1	20.7	21.3	22.2	k _{VS} = 23.1
cv-value	17.7	20.1	22.5	24.8	26.2	26.9	26.3	25.5	24.6	24.5	23.7	24.0	24.7	25.8	c _{VS} = 26.8

V5032...B (DN40)

Setting	0.5	1.0	1.2	1.4	1.5	1.6	1.8	2.0	2.2	2.4	2.6	2.8	3.0	3.2	3.4	3.6
kv-value	2.1	2.4	2.6	2.8	2.9	3.0	3.4	3.9	4.7	5.5	6.3	7.3	8.3	9.4	10.6	12.1
cv-value	2.4	2.8	3.1	3.3	3.4	3.5	3.9	4.6	5.4	6.4	7.4	8.4	9.6	10.9	12.3	14.0

Setting	3.8	4.0	4.2	4.4	4.6	4.8	5.0	5.2	5.4	5.6	5.8	6.0	6.2	6.4	6.5 = open
kv-value	14.0	16.5	19.1	21.2	22.7	23.3	23.3	22.7	21.5	20.0	19.6	19.8	20.4	21.3	k _{VS} = 21.4
cv-value	16.3	19.1	22.2	24.6	26.3	27.1	27.0	26.4	25.0	23.3	22.8	23.0	23.7	24.8	c _{VS} = 24.9

V5032...B (DN50)

Setting	1.0	1.2	1.4	1.6	1.8	2.0	2.2	2.4	2.6	2.8	3.0	3.2	3.4	3.6	3.8	4.0	4.2	4.4
k_v-value	0.2	0.3	0.8	1.6	2.8	4.3	6.0	8.2	10.7	13.6	17.1	20.8	24.8	28.8	31.6	33.0	33.2	33.3
cv-value	0.2	0.3	0.9	1.9	3.2	4.9	7.0	9.5	12.4	15.8	19.8	24.2	28.9	33.5	36.7	38.4	38.6	38.7

Setting	4.6	4.8	5.0	5.2	5.4	5.6	5.8	6.0	6.2	6.4	6.6	6.8	7.0	7.2	7.4	7.6	7.9 = open
k_v-value	33.3	33.9	34.9	35.8	36.4	38.0	39.8	42.1	44.2	45.7	47.1	48.7	50.4	51.8	50.7	48.8	k _{vS} = 46.9
cv-value	38.7	39.4	40.6	41.7	42.3	44.1	46.2	48.9	51.4	53.2	54.7	56.6	58.6	60.2	59.0	56.7	c _{vS} = 54.6

V5032...B (DN65)

Setting	1.0	1.2	1.4	1.6	1.8	2.0	2.2	2.4	2.6	2.8	3.0	3.2	3.4	3.6	3.8	4.0	4.2	4.4
k_v-value	0.3	0.5	1.1	1.6	2.4	3.5	4.9	6.6	8.7	11.0	13.4	15.8	18.2	20.5	22.6	24.7	26.7	28.8
cv-value	0.4	0.6	1.2	1.9	2.8	4.0	5.7	7.7	10.1	12.8	15.6	18.4	21.1	23.8	26.3	28.7	31.1	33.4

Setting	4.6	4.8	5.0	5.2	5.4	5.6	5.8	6.0	6.2	6.4	6.6	6.8	7.0	7.2	7.4	7.6	7.9 = open
k_v-value	30.8	33.0	35.2	37.5	39.7	41.7	43.3	44.6	45.5	46.2	46.6	46.9	47.1	47.2	47.3	47.3	k _{vS} = 47.4
cv-value	35.8	38.4	41.0	43.6	46.2	48.4	50.4	51.8	52.9	53.7	54.2	54.5	54.7	54.9	55.0	55.0	c _{vS} = 55.1

V5032...B (DN80)

Setting	1.0	1.2	1.4	1.6	1.8	2.0	2.2	2.4	2.6	2.8	3.0	3.2	3.4	3.6	3.8	4.0	4.2	4.4
k_v-value	13.9	16.7	19.8	13.0	26.2	29.6	32.9	36.2	39.4	42.5	45.6	48.5	51.3	54.0	56.5	58.9	61.2	63.3
cv-value	16.2	19.5	23.0	26.7	30.5	34.4	38.2	42.1	45.8	49.4	53.0	56.4	59.7	62.8	65.7	68.5	71.2	73.6

Setting	4.6	4.8	5.0	5.2	5.4	5.6	5.8	6.0	6.2	6.4	6.6	6.8	7.0	7.2	7.4	7.6	7.9 = open
k_v-value	65.2	67.1	68.7	70.3	71.7	73.0	74.1	75.2	76.1	76.9	77.7	78.4	78.9	79.5	79.9	80.3	k _{vS} = 80.9
cv-value	75.9	78.0	79.9	81.7	83.3	84.8	86.2	87.4	88.5	89.5	90.3	91.1	91.8	92.4	92.9	93.4	c _{vS} = 91.0

Influence of Coolants on Flow Values

The flow through a valve is defined by the k_v-value. The k_v-value is the flow m through a valve in [m³/h] at a differential pressure of 1 bar (14.5 psi) and is only valid for fluids with a density of ρ₀ = 1000 kg/m³. This condition is met by water at a temperature of 20°C (68°F). For fluids with another density the following formula can be applied:

$$k_{v_{Medium}} = \frac{m}{\sqrt{\Delta p}} \times \frac{\sqrt{\rho_{Medium}}}{\sqrt{\rho_0}}$$

Correction Factor f

When the density σ is expressed in t/m³ instead of kg/m³ the correction factor f is the result. The correction factor f can be used to re-calculate k_v -value, pressure drop and flow:

$$k_{v_{Medium}} = k_{v_0} \times \frac{1}{\sqrt{f}} \quad \Delta p_{Medium} = \Delta p_0 \times f \quad m_{Medium} = m_0 \times \frac{1}{\sqrt{f}}$$

Table 1. Values for correction factor f

Medium	Water part	Correction factor f					
		5°C (41°F)	20°C (68°F)	35°C (95°F)	50°C (122°F)	65°C (149°F)	80°C (176°F)
Normal water	100%	1.000	0.998	0.994	0.988	0.981	0.972
Ethylen glycol e.g. Antifrogen N	70%	1.052	1.047	1.041	1.033	1.024	1.015
	50%	1.086	1.079	1.070	1.061	1.052	1.042
Propylen glycol e.g. Antifrogen L	70%	1.035	1.029	1.021	1.012	1.002	0.991
	50%	1.053	1.044	1.035	1.025	1.014	1.002

For more information,

<https://honeywellbuildings.in>

Call: 1-800-103-0339

Email: HBT-Indiabuildings@honeywell.com

Honeywell HBT India Buildings

Unitech Trade Center, 5th Floor, Sector-43,
Block C, Sushant Lok Phase - I,
Gurgaon - 122 002