



Flamco Airfix D-E



6442.eps



© 1999, Flamco



Installation and operating instructions



Flamco



Exclusion of liability

All operation and maintenance related technical information, data and instructions contained in these installation and maintenance instructions correspond to the latest status when this went to print. To the best of our knowledge they include our present experience and findings.

We reserve the right to make technical alterations arising out of the ongoing development of the Flamco product presented in these installation and operating instructions. Therefore, no claims can be derived from the technical data, descriptions and illustrations.

Technical illustrations, drawings and graphics do not necessarily correspond to the actual delivered item - subassembly, individual component or replacement part. Drawings are not to scale and also include symbols for the sake of simplification.



Airfix D-E Installation and operating instructions

Dear Customer,

With the Airfix D-E membrane expansion vessel you have acquired a Flamco quality product.

This expansion vessel offers safe and reliable operation and simplicity of installation. In the following text you will find technical data, instructions and explanations to allow you to work properly and operate the equipment in safety.

Anybody instructed to carry out work or other operations on this expansion vessel must read these installation and operating instructions carefully.

We will be glad to answer any questions that cannot be clarified by the contents of this documentation.

Table of Contents

Chapter	Page
General	3
Technical data, equipment	4
Method of operation	6
Transport and storage	6
Assembly and installation	7
Commissioning	11
Maintenance, regular inspection	11
Annex: I	12

Additional technical information as well as supplemental details on special versions that we can provide is attached to this documentation as an appendix.

General

The Airfix D-E expansion vessel is a pressurised tank with a full membrane and adjustable gas admission pressure. It is intended for use in conformity with DIN 4807-5 and DIN 1988 in potable water systems and potable-water heating systems.

To design the system, it is advisable to use the Flamco calculation disk for expansion vessels, which can be obtained on request from the Flamco Sales Office.



Technical data, equipment

The vessels are supplied as steel, upright models, painted on the outside and with a replaceable membrane. They are delivered on their side, packed on a non-returnable pallet.

Specifications of vessel

In compliance with DIN 4807-5, the vessel is manufactured and tested as specified in the German Pressure Vessel Regulations (DruckbehV). The membrane meets the requirements of DIN 4807-3 and DIN 4807-5.

Maximum operating pressure: 10 and 16 bar
Maximum operating temperature: 70 °C/343 K (vessel and membrane)
Type tested, Test-No.: ZU 295/12 for the 10 bar version
Test-No.: ZU 295/13 for the 16 bar version

or individual safety standards inspections in the case of special versions

Maximum water take-up capacity: 60% of nominal
Maximum permissible gas admission pressure in the vessel's as delivered condition: 6 bar

The high quality butyl rubber membrane material ensures a low degree of permeability (gas transfer) which can practically be ignored in the vessel's intended function.

Components and scope of supply

Fig. 2
Model plate

6353

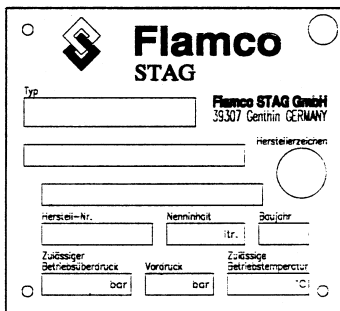

Please see the model plate (item 12) for the technical data on your version of the vessel

Fig. 1

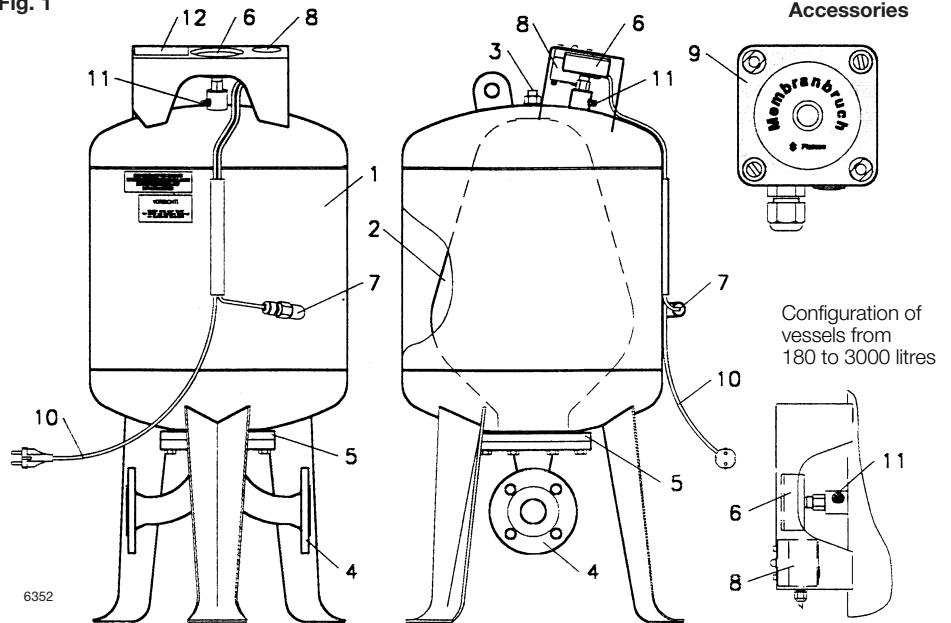

- 1 Steel tank, externally painted in yellow-green
- 2 Butyl membranes, KTW-C/W270
- 3 Membrane mounting (600 litres and up, inside the vessel)
- 4 Double system connection, coated internally to DIN 4753-4, direction of flow optional **OPTION**, a version in stainless steel 1.4301
- 5 Inspection port (600 litres and up, top and bottom)
- 6 Pressure gauge with gas blow-back protection, vessel connection Rp3/8 DIN 2999-1
- 7 Sensor for membrane ruptures, including signal cable
- 8 Membrane rupture indicator, basic unit, visual indication of membrane rupture given by a red LED
 Nominal voltage: 230V 50 Hz
 Nominal current: 9mA (2VA)
 Protection grade: IP65



- 9 **Accessories:** membrane rupture remote indicator, extension module
 Input: 5V DC from the basic unit's voltage supply.
 Nominal current: ca. 100 mA
 Cable section: 2x1,5² for cable lengths in a \leq of 500 m. Installation by the customer.
 Output: assignable floating contacts, makers and breakers
 Nominal max current: 8 A
 Nominal voltage: 230 V AC
 Installation by the customer
- 10 Electrical power cable and voltage supply for basic unit and remote indicator
 Length of the cable plus plug 10A 250V VDE: 6m (from the basic unit's output)
- 11 Gas filling valve, test connection
- 12 Model plate





Tank dimensions, vessel connection specifications

The stated dimensions are nominal values.

Table 1 Primary specifications

Model	Total capacity Litres	Tank diameter mm	Max height mm		Inspection port ø mm		Weight kg	
			10 bar	16 bar	top	bottom	10 bar	16 bar
Airfix D-E 50	50	450	845	845	-	120	60	70
Airfix D-E 80	80	450	1025	1025	-	120	70	80
Airfix D-E 120	120	450	1280	1280	-	120	80	95
Airfix D-E 180	180	550	1235	1245	-	120	110	135
Airfix D-E 240	240	550	1495	1505	-	120	130	160
Airfix D-E 300	300	550	1835	1845	-	120	150	190
Airfix D-E 600	600	750	1850	1850	160	120	230	300
Airfix D-E 800	800	750	2240	2240	160	120	270	350
Airfix D-E 1000	1000	750	2740	2740	160	120	320	415
Airfix D-E 1600	1600	1000	2670	2690	250	165	550	610
Airfix D-E 2000	2000	1200	2420	2435	250	165	620	680
Airfix D-E 3000	3000	1200	3320	3335	250	165	805	890

Fig. 3

Bottom view

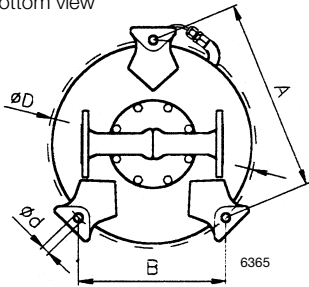

Tank diameter

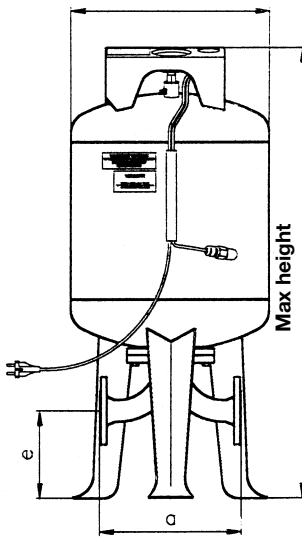
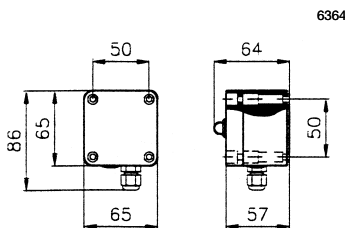

Fig. 4

Remote indicator dimensions

Accessories



Locating holes Ø 5 for 2 securing screws

Table 2 Bottom connection

Model	Hole diameter mm d	Hole spacing mm		Base circle diameter mm D
		A	B	
Airfix D-E 50	20	434	332	470
Airfix D-E 80				
Airfix D-E 120				
Airfix D-E 180	535	485	410	
Airfix D-E 240				
Airfix D-E 300				
Airfix D-E 600	680	589	589	
Airfix D-E 800				
Airfix D-E 1000				
Airfix D-E 1600	690	598	598	
Airfix D-E 2000				
Airfix D-E 3000				
Airfix D-E 2000	840	728	728	
Airfix D-E 3000				

Table 3 Duo system connection

Model	Double system connection		Connection PN 16	Water flow with a pressure loss of 0,2 bar
	Length mm a	Height mm e		
Airfix D-E 50	320	190	Flange C40 DIN 2633 (DN 40)	14,4 m³/h
Airfix D-E 80				
Airfix D-E 120				
Airfix D-E 180	390	140	Flange C50 DIN 2633 (DN 50)	21,1 m³/h
Airfix D-E 240				
Airfix D-E 300				
Airfix D-E 600	370	275	Flange C80 DIN 2633 (DN 80)	46,9 m³/h
Airfix D-E 800				
Airfix D-E 1000				
Airfix D-E 1600	260	260	Flange C80 DIN 2633 (DN 80)	46,9 m³/h
Airfix D-E 2000				
Airfix D-E 3000				



Method of operation

The Airfix D-E membrane expansion vessel contains a gas chamber between the tank's inner surface and the membrane's outer surface as well as a water chamber inside the membrane. The gas chamber is adjusted to the required pressure in relation to the system specifications. A rise in pressure in the water chamber compresses the volume of gas and fills the membrane, whilst a reduction in pressure causes a water release. If the pressure in the gas chamber reaches the set water pressure in the system, water is drawn from the supply pipe.
In this status, water passes through the vessel with a very low loss of pressure.

Use in potable water heating systems

The vessel is installed in the cold water feed and takes up the heat expanded overflow volume. Drawing off water or a reduction in temperature leads to the water that has been taken up being released into the system.

Fig. 5

Illustration of the principles of operation

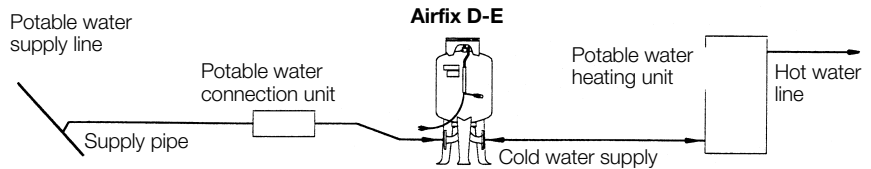

6366

Use in pressure-boosting systems

The vessel can be used both on the admission pressure and the ultimate pressure sides. These installations are intended to prevent unacceptable water hammer in the event of minimum flow speeds and minimum supply pressures not being reached.

• Operation on the admission pressure side

The vessel is installed in the pump delivery line. It provides a supply of water to meet the demand and reduces the frequency for operating the pumps.

• Operation on the ultimate pressure side

The vessel is installed in the pump delivery line. It provides a supply of water to meet the demand and reduces the frequency with which the pumps are engaged.

Fig. 6

Illustration of the principles of operation

Example of installation on the admission and ultimate pressure

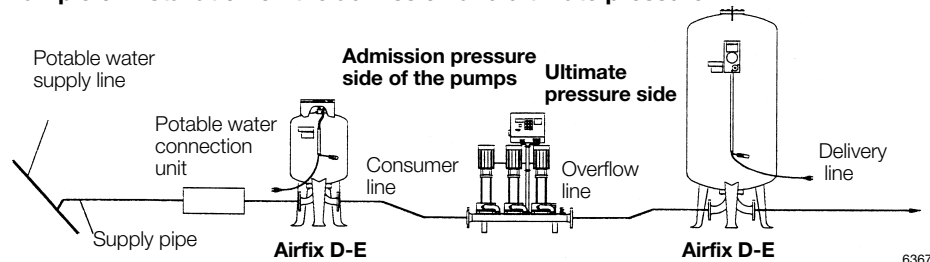

6367

Transport and storage

Airfix D-E membrane expansion vessels are delivered on their side on a non-returnable pallet in fully assembled condition. Additional fittings may be packed separately. The vessel should be removed from its packing and placed where it is to be used. Fittings (lugs) on the vessel to take up the strain are only to be used for transporting empty, uninstalled (as delivered) tanks. The vessel can also be temporarily stored in its packing. The necessary conditions for this are: an enclosed, frost free and dry area, with no vibrations and protection from heat and sunlight. Vessels must not be stacked on top of each other!



Assembly and installation

Ambient conditions

The membrane expansion vessels must be placed so that their operation, inspection and maintenance can constantly be ensured.
The tanks must be set up in an enclosed, frost free area, observing the minimum distances shown in Table 4.
The safe ambient temperature range for the vessel is 5-40 °C.

Table 4

Minimum distances

Fig. 7

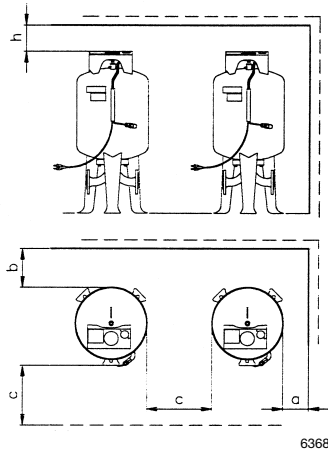

Model	Height mm h	Width mm		
		a	b	c
Airfix D-E 50 Airfix D-E 80 Airfix D-E 120 Airfix D-E 180 Airfix D-E 240 Airfix D-E 300	650		650	
Airfix D-E 600 Airfix D-E 800 Airfix D-E 1000	1000	500		800
Airfix D-E 1600 Airfix D-E 2000 Airfix D-E 3000			1000	

c: minimum clearance width

Foundations and mounting

The standing surface must be prepared so as to ensure that the vessel can stand on it securely and maintain an upright position.
The max. operating weights in Table 5 (the complete vessel including water filling) must be taken into account when constructing this surface.
The vessel must be mounted vertically (perpendicularly).

Table 5

Operating weight in kg

Airfix D-E Capacity in litres												
50	80	120	180	240	300	600	800	1000	1600	2000	3000	
120	160	220	320	400	490	900	1150	1420	2210	2680	3890	

Irrespective of the individual case, operation of the Airfix D-E 50-3000 litres in pressure-boosting systems and as a water hammer suppresser requires a mounting. If used for other applications, a mounting must be provided from and including 300 litres and upwards (see also Page 6).

Details of available dimensions for the bottom connection are contained in Table 2 on Page 5.

Avoid those types of mountings that would adversely affect the vessel. Do not, for example, set the container's feet in concrete or plaster, nor weld the vessel or its base, nor clamp or tension its base plate nor suspend it.



Electrical connection of the membrane rupture indicator, performed by the customer

Airfix D-E units are delivered with an installed membrane rupture indicator (see also Page 4, Technical data). This piece of equipment should be connected to a 10A 250V AC VDE wall or extension socket using the plug lead provided.

If the remote indicator is used as an additional module to the basic unit, the customer should install the equipment in accordance with the following instructions. The membrane rupture indicator and the remote indicator have protective insulation and therefore there is no need for any additional protective measures (potential equalisation between the unit's mounting surfaces and the equalisation lead is not necessary).

Electrical items included in the delivery



- 6371
- Danger, high voltage!
- Only carry out installation and maintenance work:
- if the membrane rupture indicator's mains plug has been taken out of the connecting socket,
 - if any voltage running through the contacts for additional signal analysis of the remote indicator has been switched off,
 - if the mains feed is protected against being switched on again, use insulated tools.
 - lock the units after carrying out the installation.

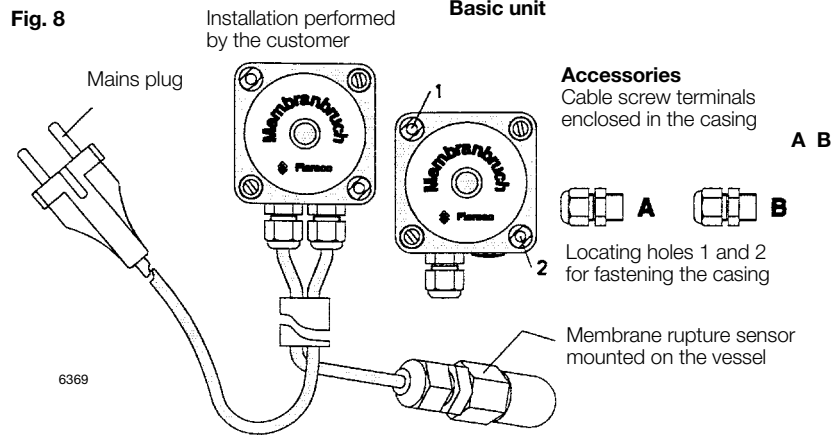

Electrical connection of the remote indicator, performed by the customer

The obligatory provisions for the intended individual case and installation point apply. Ensure that the installation is carried out by professionals trained in electrical installation work.

Fig. 10
Circuit diagram
Signal analysis
Remote indicator

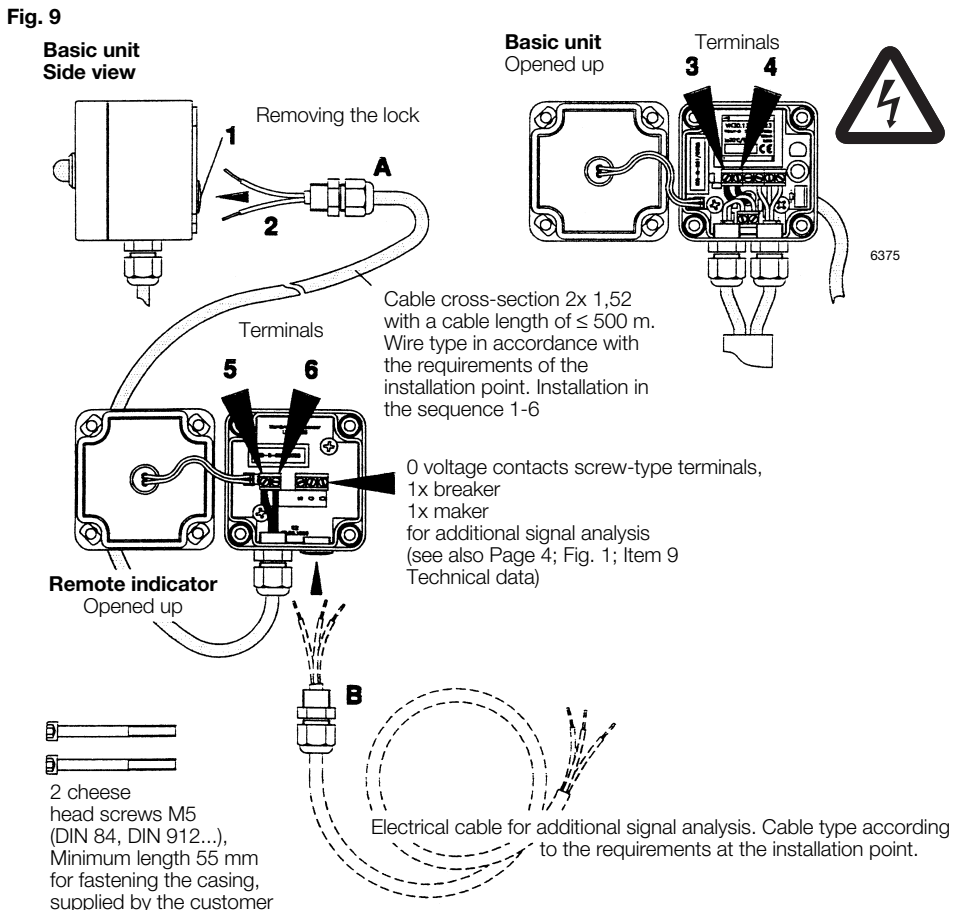
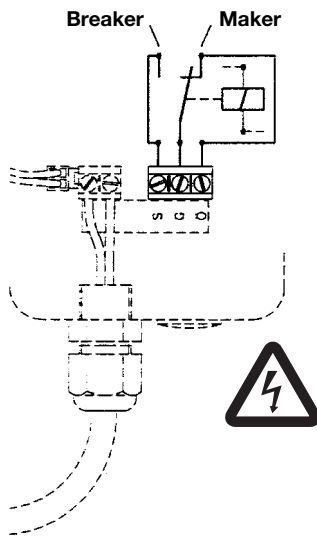



Installation

The obligatory provisions for the relevant individual case and location apply. In addition, the following general rules for installation must be observed.

- The double system connection must be installed as a connection to the supply line.
- Note that the vessel must be operated in flow-through mode as specified in DIN 4807-5 in every application. You must not install the unit in the stub or by-pass line.
- Ensure that this connection is made directly to the main potable water flow line.
- Installation of the double system connection is not governed by the direction of flow.
- Standing surfaces with a uniform level are preferred if more than vessel is being used (to increase capacity).
- Prevent the permissible water take-up volume (60% of nominal volume) from being exceeded.
- Choose sealants and feed lines in accordance with the project but which at least cope with the max possible pressure and temperature values on this supply line.
- Fit a shut-off device directly in the vicinity of the system connection to ensure against unintentional closure (fit one on each side if necessary).
- Install a filling and emptying device between the shut-off device and the system connection.
- When welding, prevent any weld metal from getting on or into the expansion vessel.

Important information on the gas admission pressure



If it is necessary to use a vessel with a gas admission pressure greater than 6 bar, this pressure this pressure must be established using nitrogen if there is a counter-pressure on the water lines side. When building up the gas admission pressure to above 6 bar the difference between the water and gas pressures should be a maximum of 3 bar.

The top-up unit must be fitted with a suitable, tested safety valve.

We would ask you to particularly take care that during assembly and dismantling as well as under special operating conditions (e.g. emptying the vessel) the difference between the gas admission pressure and the pressure at the system connection is not greater than 6 bar (e.g.: gas admission pressure 8 bar minus water pressure 2 bar equals 6 bar).

If more than one vessel is being used and they are not arranged on the same level, the relevant static height for setting the gas admission pressure must be taken into account.

Fig. 11

Notes on the vessel:

**THE VESSEL MUST BE INSTALLED
IN THE COLD WATER SUPPLY LINE
WHEN USED IN WATER
HEATING SYSTEMS**

WARNING!
The vessel is under pressure! Before opening the vessel, check the gas pressure at the gas admission valve!

• Incorporation into potable water heating systems

The regulations, especially DIN 1988-2 and -4, governing potable water installations apply to this usage.

The expansion vessel must be fitted to the cold water line.

If the potable water connection unit does not include a pressure reducer, this must be provided to ensure a constant steady pressure.

The safety provisions specified in DIN 1988-2, section 4.3.4.1.1. "Safety valves in closed potable water heaters" must be observed.

The expansion vessel's admission pressure is adjusted by taking the admission/steady pressure behind the pressure reducer and subtracting 0.2 bar. If the pressure reducer and the expansion vessel are not on the same level, this must be taken into account accordingly.



Fig. 12

Installation diagram for potable water heating systems

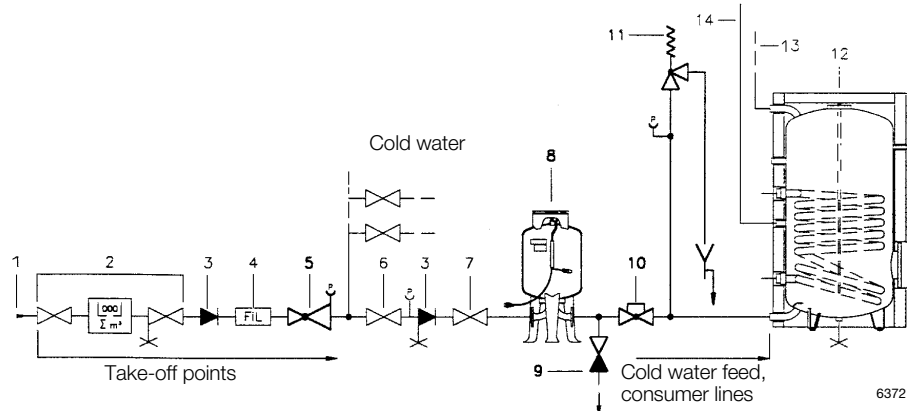

- | | |
|--|---|
| 1 Potable water supply line | 9 Drainer |
| 2 Water meter system | 10 Shut-off device secured against unintentional closure (e.g. cap valve with wire and lead seal) |
| 3 Back-flow preventer | 11 Safety valve |
| 4 Filter | 12 Storage-type water heater |
| 5 Pressure reducer with test connection | 13 Hot water line |
| 6 Shut-off valve | 14 Circulation line |
| 7 (Shut-off valve > 150 litres water heater) | |
| 8 Membrane expansion vessel Airfix D-E | |

• Installation in pressure-boosting systems

The regulations, in particular DIN 1988-2; -4; -5 and -6 governing potable water installations apply to this application. The details given by the pressurised system manufacturer should also be noted.

Directly connected systems (where the pressure-boosting system is directly connected to the supply line branching off from the feeder line) require receivers as specified in DIN 4807-5 where expansion vessels are to be used on the admission pressure and ultimate pressure sides.

An exception is the case of indirect connection and expansion vessels in lines carrying non-potable water (vessels with a single connection and no through flow may be used - see also Annex 1). We would however point out that a very low loss of pressure is achieved when operating a vessel with a direct through flow, which has a positive impact on the systems energy consumption.

• Installation as a water hammer suppresser

The regulations governing potable water installations apply to this application. The details given by the water hammer suppresser manufacturer should also be noted.

The size and use of expansion vessels to reduce water hammer caused by rapid shut-off devices must be determined in accordance with the necessary system parameters and the device's characteristics.

According to the requirements for suppression, the vessel's placement in the conduit system can be in the supply and/or the drain side.



Commissioning

The regulations for potable water installations apply, in particular DIN 1988-8. In addition, the following general rules on commissioning apply. (Note also the installation instructions on Pages 7 to 10)

- Check and set the necessary system pressure.
- Check the gas admission pressure, which was set according to the vessel's application and which must not exceed the maximum figure of 6 bar before the vessel is filled.
- Inspect the pressure limiting safety fittings for correct operation and reliability.
- Connect the membrane rupture indicator to the voltage supply.
- Slowly open the supply valves for filling the vessel.

Maintenance, regular inspection

Maintenance on the vessel should be carried out annually by a contract plumbing and heating firm.

SCOPE OF THE MAINTENANCE:

- Checking the system pressure in relation to which the vessel's required gas admission pressure was determined. The pressure reducer should be adjusted as necessary.
- Checking the gas admission pressure and correcting it to the required value according to the project. Nitrogen should be used for raising the pressure and the top-up unit must be fitted with a suitable, tested safety valve.

Note that this inspection requires the unit to be isolated via shut-off valves on the water side and complete drainage of the water chamber (no pressure on the vessel's water side). Also note the valve configuration as shown in Fig. 12, Page 10.

- Leak test of the vessel's connections.
 - 1 System connection and lower tank flange connection
 - 2 Pressure gauge and filling valve connection
 - 3 Membrane rupture sensor connection
 - 4 Membrane mounting (upper) and tank flange (upper) on Airfix D-E 600 litre models and above.
- Function test of the equipment items. Use Flamco approved spares or accessories. Prevent items delivered by Flamco from being rebuilt or modified at someone's own initiative.
- Check the item's exterior for damage and corrosion. Deformation or rust on pressurised components can cause unacceptable stresses or strains, with a possible consequence of components being destroyed and people being put at risk.

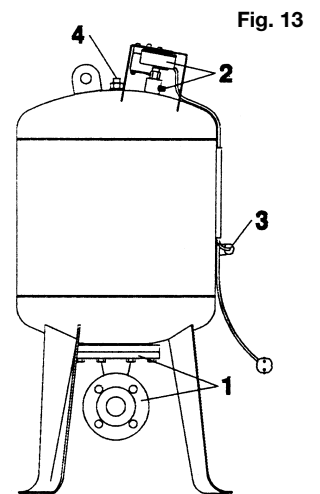

Fig. 13

6373

We recommend that you use Flamco's Customer Service for your maintenance work.

Regular inspection

The fixed periods and scope of the inspection as laid down in the Pressure Vessels Regulations (DruckbehV.) apply. For inspection operations, the works and acceptance certificate including the acceptance diagram are available to the operator.

Table 6

Inspection periods

Type of inspection	Inspection interval Year	Inspector in charge	
		Airfix D-E 50/80 10 bar Airfix D-E 50 16 bar	Airfix D-E 120-3000 10 bar Airfix D-E 80-3000 16 bar
External inspection	2	The expert authority as specified in Paragraph 32 of the DruckbehV.	The specialist as specified in Paragraph 31 of the DruckbehV.
Internal inspection	5		
Internal inspection	10		



Annex I

Airfix D-E applications in indirectly connected systems or systems where vessels are installed in lines carrying **NON-POTABLE WATER**.

This type of installation **LIES OUTSIDE THE SCOPE OF DIN 4807-5** and can be carried out if necessary using a non through-flow mono connection (for an installation in the stub or by-pass line).

The scope of supply corresponds to the design specified in DIN 4807-5 (see Page 4, Technical Data), but with item 4 in a mono connection design instead of a double system connection.

Table 6 contains the connection dimensions.

4 Mono system connection, internally coated as specified in DIN 4753-4 OPTION, a version in stainless steel 1.4301

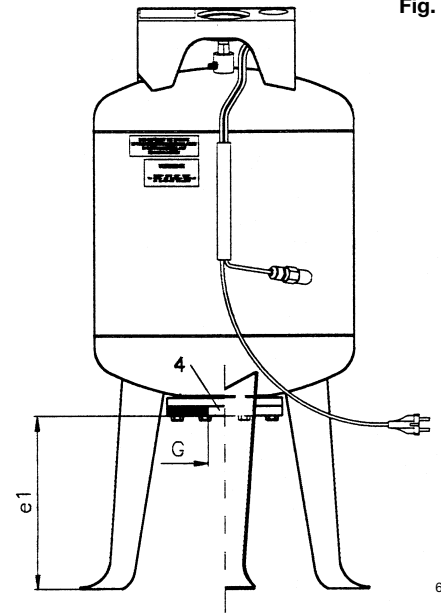

Table 7

Mono system connection

Model	PN 16 single system connection Height mm e1	Wt DIN ISO 228-1
Airfix D-E 50	300	1 1/2" (DN 40)
Airfix D-E 80		
Airfix D-E 120		
Airfix D-E 180		
Airfix D-E 240		
Airfix D-E 300		
Airfix D-E 600	280	2" (DN 60)
Airfix D-E 800		
Airfix D-E 1000		
Airfix D-E 1600	390	2 1/2" (DN 65)
Airfix D-E 2000		
Airfix D-E 3000		

Dimensions are nominal values