

Datasheet

Part no. and prices: See pricelist



- Multi mode heating water buffer cylinder with integral DHW heating
- 750 and 950 l with integral indirect coil for connection to solar collectors
Vitocell 360-M also available with stratification system

VITOCELL 340-M

Vitopearlwhite

400 l, type SVKA
750 l, type SVKC
950 l, type SVKC

Vitosilver

750 l, type SVKC
950 l, type SVKC

Vitographite

400 l, type SVKA
750 l, type SVKC
950 l, type SVKC

VITOCELL 360-M

Vitopearlwhite

750 l, type SVSB
950 l, type SVSB

Vitosilver

750 l, type SVSB
950 l, type SVSB

Vitographite

750 l, type SVSB
950 l, type SVSB

Benefits

Type SVSB

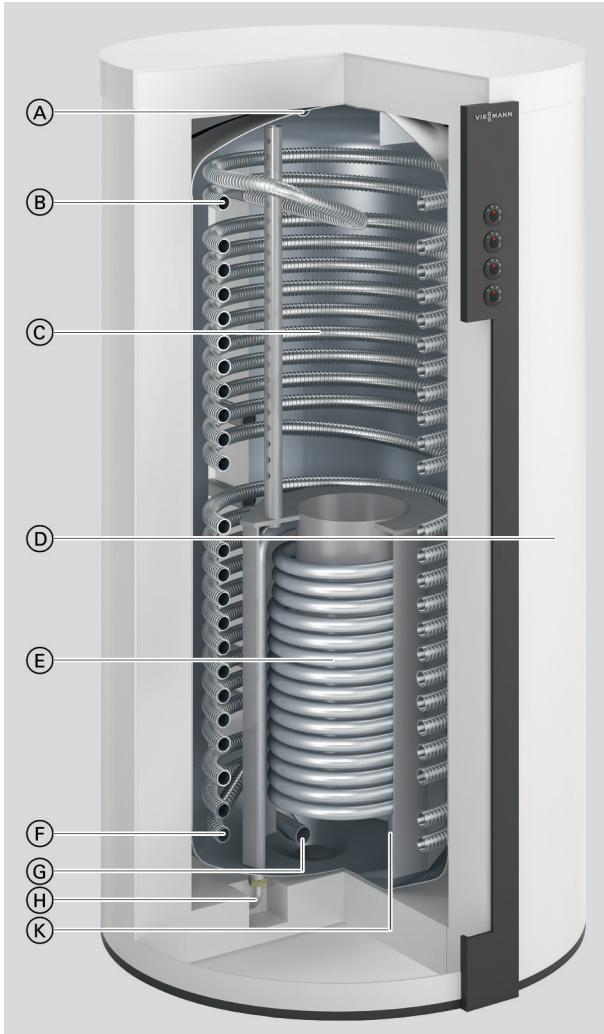

- Ⓐ Heating water flow 1/air vent valve
- Ⓑ DHW/DHW circulation
- Ⓒ Corrugated DHW pipe made from stainless steel
- Ⓓ Installation position of immersion heater EHE (accessories)
- Ⓔ Stratification system
- Ⓕ Cold water
- Ⓖ Drain outlet
- Ⓗ Heating water flow/solar thermal system air vent valve
- Ⓚ Heating water return/solar thermal system drain outlet (concealed)

- Vitocell 340-M/360-M — combination of heating water buffer cylinder and DHW cylinder
- For heating systems with several heat generators. Particularly suitable in conjunction with Viessmann solar thermal systems for DHW heating and central heating backup
- Connections at different heights enable the utilisation of different heat generators, e.g. a solid fuel boiler. The temperature stratification remains unaffected.
- Modest space requirement and straightforward installation — combined DHW cylinder and buffer cylinder in a single appliance

- Corrugated DHW pipe made from high-alloy stainless steel, integrated inside the cylinder to be flexible and stress-free
- Optimum utilisation of solar energy through deliberate cooling in the lower section via the large indirect coil surface of the corrugated DHW pipe
- Vitocell 360-M: The stratification system ensures that the water heated by solar energy is stratified into temperature layers, making DHW heated in this way available very quickly.

Delivered condition

Type SVKA

Multi mode heating water buffer cylinder with **400 l** capacity:

- Removable thermal insulation
- Polystyrene casing: Vitoppearwhite or Vitographite
- Adjustable feet
- Cylinder made from steel with stainless steel indirect coil for DHW heating
- 2 integral welded sensor wells (internal diameter 16 mm) for cylinder temperature sensors or temperature controllers
- 2 thermometers for installation in the front cover strip
- 1 clamping bracket for thermometer sensor or additional temperature sensors

Type SVKC

Multi mode heating water buffer cylinder with **750 and 950 l** capacity:

- Removable thermal insulation
- Polystyrene casing: Vitoppearwhite, Vitosilver or Vitographite
- Adjustable feet
- Cylinder made from steel with stainless steel indirect coil for DHW heating
- 3 clamping devices for securing immersion temperature sensors to the cylinder jacket, each with fixing points for 3 immersion temperature sensors
- 2 thermometers for installation in the front cover strip



Benefits (cont.)

- 3 clamping brackets for thermometer sensor or additional temperature sensors
- Solar air vent valve
- Indirect coil for the connection of solar collectors

Type SVSB

Multi mode heating water buffer cylinder with **750 and 950 l** capacity:

- Removable thermal insulation
- Polystyrene casing: Vitoppearlwhite, Vitosilver or Vitographite
- Adjustable feet

- Cylinder made from steel with stainless steel indirect coil for DHW heating
- Indirect coil with stratification system for the connection of solar collectors
- 3 clamping devices for securing immersion temperature sensors to the cylinder jacket, each with fixing points for 3 immersion temperature sensors
- 2 thermometers for installation in the front cover strip
- 3 clamping brackets for thermometer sensor or additional temperature sensors
- Solar air vent valve

Specification for type SVKA

Sizing entry points

The actual dimensions of the DHW cylinder may vary slightly due to manufacturing tolerances.

Specification

Type		SVKA
Cylinder capacity (AT: Actual water capacity)	l	400
Solar indirect coil capacity	l	—
DHW indirect coil capacity	l	22
Heating water capacity	l	378
DIN registration number		Applied for
Standby heat loss	kWh/24 h	1.8
Permissible heating water flow temperature	°C	110
Permissible operating pressure on the heating water side	bar	3
	MPa	0.3
Dimensions		
Length a (∅)		
– Incl. thermal insulation	mm	859
– Excl. thermal insulation	mm	650
Width b		
– Incl. thermal insulation	mm	885
– Excl. thermal insulation	mm	862
Height c		
– Incl. thermal insulation	mm	1624
– Excl. thermal insulation	mm	1506
Height when tilted		
– Excl. thermal insulation and adjustable feet	mm	1550
Weight		
– Incl. thermal insulation	kg	125
– Excl. thermal insulation	kg	108
Connections (male thread)		
Heating water flow and return	R	1¼
Cold water/DHW	G	1
DHW indirect coil		
Heating surface	m ²	5.5
Energy efficiency class		
		B
Colour		
		Vitoppearlwhite or Vitographite

Other multi mode heating water buffer cylinders without solar indirect coil: See Vitocell 320-M datasheet.

Specification for type SVKA (cont.)

Dimensions of type SVKA

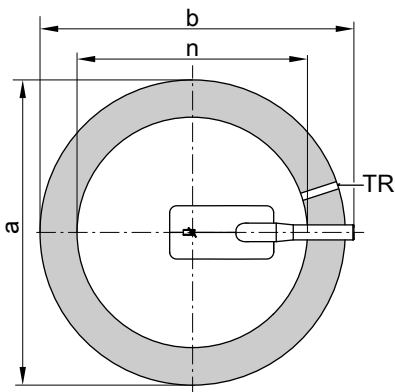
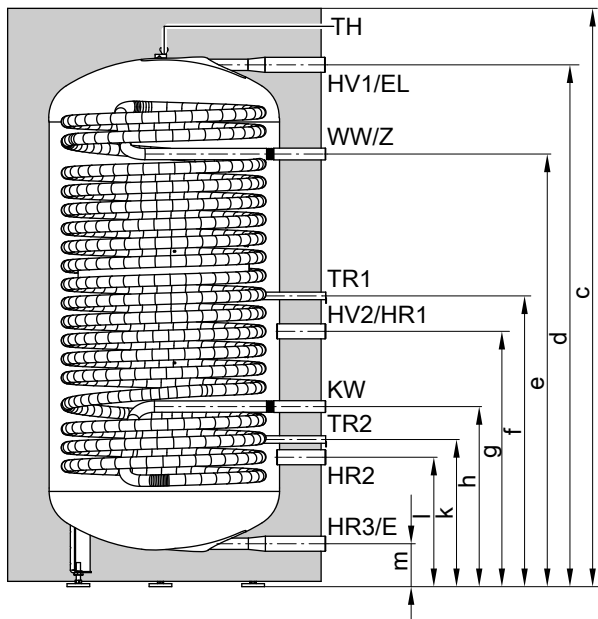

- HR Heating water return
- HV Heating water flow
- KW Cold water
- TH Retainer for thermometer sensor or additional sensor (clamping bracket)
- TR Sensor well for cylinder temperature sensor and thermometer sensor
- WW DHW
- Z DHW circulation

Dimensions

Cylinder capacity		l	400
Length (∅) incl. thermal insulation	a	mm	859
Width	b	mm	885
Height	c	mm	1624
	d	mm	1457
	e	mm	1206
	f	mm	805
	g	mm	705
	h	mm	493
	k	mm	400
	l	mm	350
	m	mm	106
Length (∅) excl. thermal insulation	n	mm	650

- E Drain outlet
- EL Air vent valve

Continuous output

Continuous output at heating water flow temperature of 70 °C	kW	16	24
For DHW heating from 10 to 45 °C	l/h	321	582
– With heating water flow rate (measured via HV1/HR3)	l/h	259	488
For DHW heating from 10 to 60 °C	l/h	255	405
– With heating water flow rate (measured via HV1/HR3)	l/h	338	522

Information on continuous output

When designing systems with the specified or calculated continuous output, allow for a matching circulation pump. The stated continuous output is only achieved if the heat generator's rated heating output is \geq the continuous output.

Performance factor N_L to DIN 4708

Performance factor N_L at 70 °C heating water flow temperature

Subject to the heating output delivered by the boiler Q_D

16 kW
24 kW

3.1
3.2

Specification for type SVKA (cont.)

- The performance factor N_L depends on the cylinder storage temperature T_{cyl} .
- Cylinder storage temperature T_{cyl} = cold water inlet temperature + 50 K ^{+5 K/-0 K}

Standard values for performance factor N_L

- $T_{cyl} = 60\text{ °C} \rightarrow 1.0 \times N_L$
- $T_{cyl} = 55\text{ °C} \rightarrow 0.75 \times N_L$
- $T_{cyl} = 50\text{ °C} \rightarrow 0.55 \times N_L$
- $T_{cyl} = 45\text{ °C} \rightarrow 0.3 \times N_L$

Peak output over 10 min, relative to performance factor N_L

Peak output at 70 °C heating water flow temperature and DHW heating from 10 to 45 °C		
Subject to the heating output delivered by the boiler Q_D		
16 kW	/10 min	230
24 kW	/10 min	240

Max. draw-off rate over 10 min, relative to performance factor N_L

Max. draw-off rate at 70 °C heating water flow temperature and DHW heating from 10 to 45 °C, with reheating		
Subject to the heating output delivered by the boiler Q_D		
16	/min	23.0
24	/min	24.0

Drawable water volume

Draw-off rate with cylinder volume heated to 60 °C	/min	10	20
Drawable water volume without reheating	l	180	97
Water at $t = 45\text{ °C}$ (mixed temperature)			

Pressure drop on the DHW side

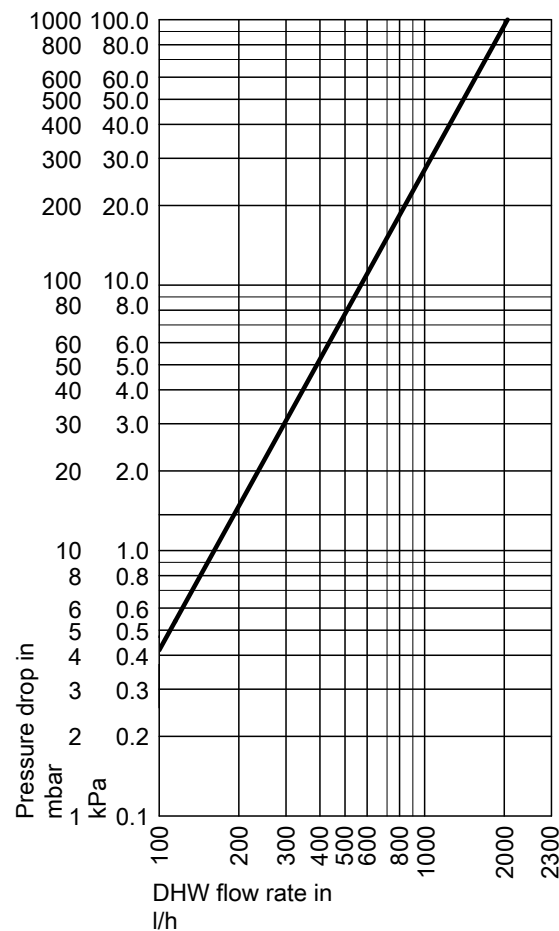

Pressure drop on the heating water side

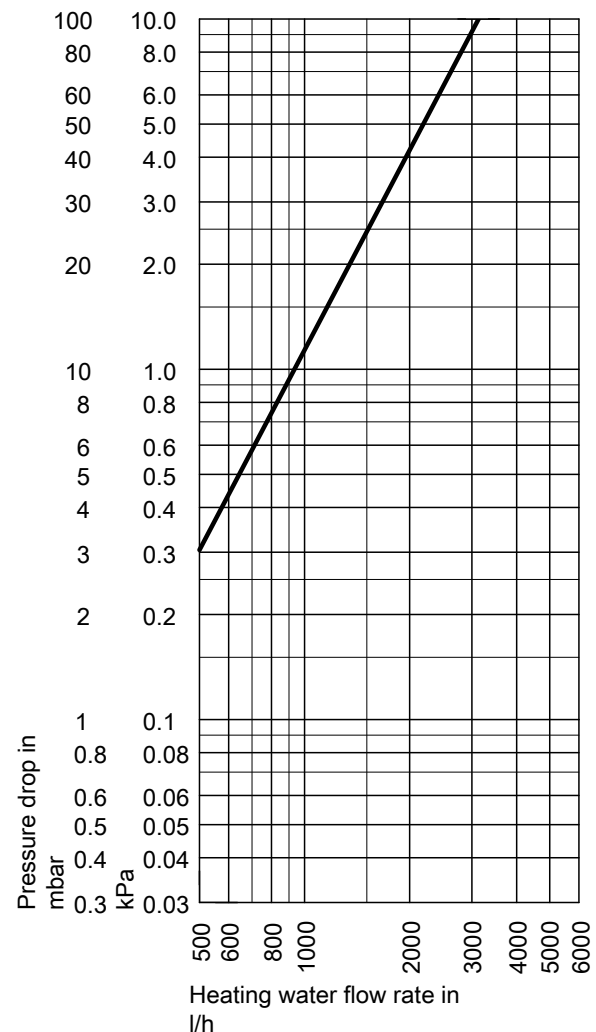

Specification for types SVKC, SVSB

Sizing entry points

The actual dimensions of the DHW cylinder may vary slightly due to manufacturing tolerances.

Specification

Type		SVKC		SVSB	
Cylinder capacity (AT: Actual water capacity)	l	750	950	750	950
Solar indirect coil capacity	l	12	14	12	14
DHW indirect coil capacity	l	30	30	30	30
Heating water capacity	l	708	906	708	906
DIN registration number		Applied for		Applied for	
Permissible temperatures					
– Heating water side	°C	110		110	
– DHW side	°C	95		95	
– Solar side	°C	140		140	
Permissible operating pressure					
– Heating water side	bar	3		3	
	MPa	0.3		0.3	
– DHW side	bar	10		10	
	MPa	1.0		1.0	
– Solar side	bar	10		10	
	MPa	1.0		1.0	
Permissible total water hardness	°dH	20		20	
	mol/m ³	3.6		3.6	
Dimensions					
Length a (∅)					
– Incl. thermal insulation	mm	1064	1064	1064	1064
– Excl. thermal insulation	mm	790	790	790	790
Width b	mm	1119	1119	1119	1119
Height c					
– Incl. thermal insulation	mm	1900	2200	1900	2200
– Excl. thermal insulation	mm	1815	2120	1815	2120
Height when tilted					
– Excl. thermal insulation and adjustable feet	mm	1890	2165	1890	2165
Weight					
– Incl. thermal insulation	kg	199	222	208	231
– Excl. thermal insulation	kg	171	199	180	208
Connections (male thread)					
Heating water flow and return	R	1¼	1¼	1¼	1¼
Cold water, DHW	R	1	1	1	1
Heating water flow and return (solar)	G	1	1	1	1
Drain outlet	R	1¼	1¼	1¼	1¼
Solar indirect coil					
Heating surface	m ²	1.8	2.1	1.8	2.1
DHW indirect coil					
Heating surface	m ²	6.7	6.7	6.7	6.7
Standby heat loss	kWh/24 h	2.25	2.45	2.25	2.45
Standby capacity V_{aux}	l	346	435	346	435
Solar capacity V_{sol}	l	404	515	404	515
Energy efficiency class		—	—	—	—
Colour		Vitopearlwhite, Vitographite or Vitosilver			

Specification for types SVKC, SVSB (cont.)

Dimensions of type SVKC

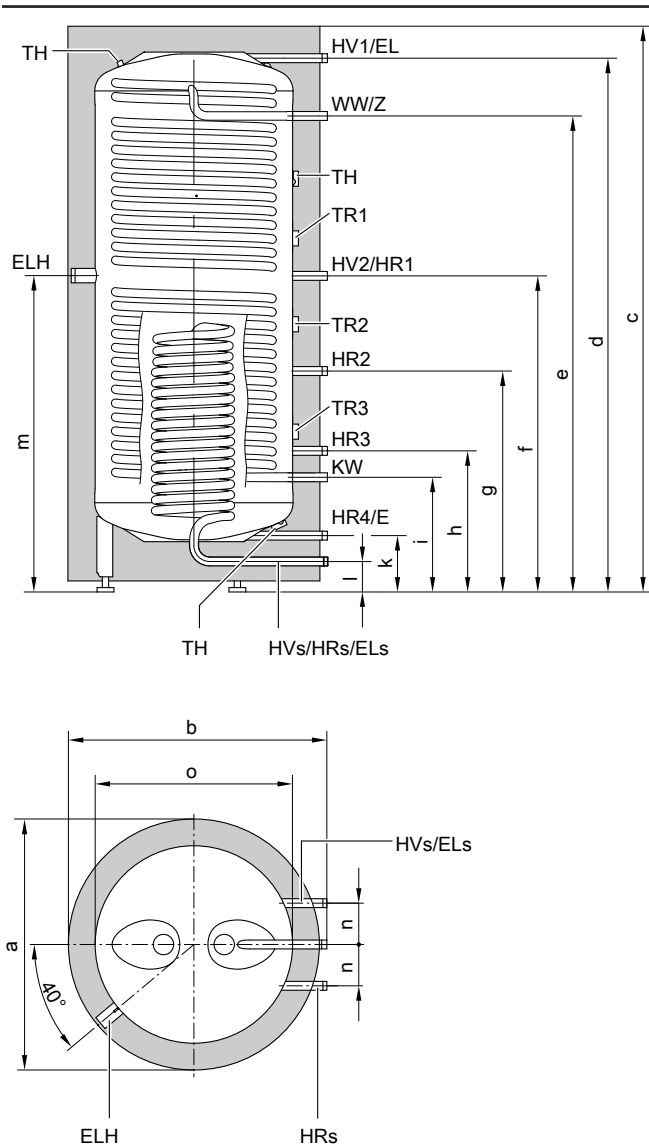

- E Drain outlet
- EL Air vent valve
- EL_s Air vent valve for solar indirect coil
- ELH Immersion heater (sleeve Rp 1½)
- HR Heating water return
- HR_s Heating water return for solar thermal system
- HV Heating water flow
- HV_s Heating water flow for solar thermal system
- KW Cold water
- TH Retainer for thermometer sensor or additional sensor (clamping bracket)
- TR Clamping device for securing immersion temperature sensors to the cylinder jacket, with fixing points for 3 immersion temperature sensors per clamping device
- WW DHW
- Z DHW circulation (threaded DHW circulation fitting, accessories)

Dimensions of type SVKC

Cylinder capacity		750	950
Length (∅)	a mm	1064	1064
Width	b mm	1119	1119
Height	c mm	1900	2200
	d mm	1787	2093
	e mm	1558	1863
	f mm	1038	1158
	g mm	850	850
	h mm	483	483
	i mm	383	383
	k mm	145	145
	l mm	75	75
	m mm	1009	1135
	n mm	185	185
Length excl. thermal insulation	o mm	790	790

Dimensions of type SVSB

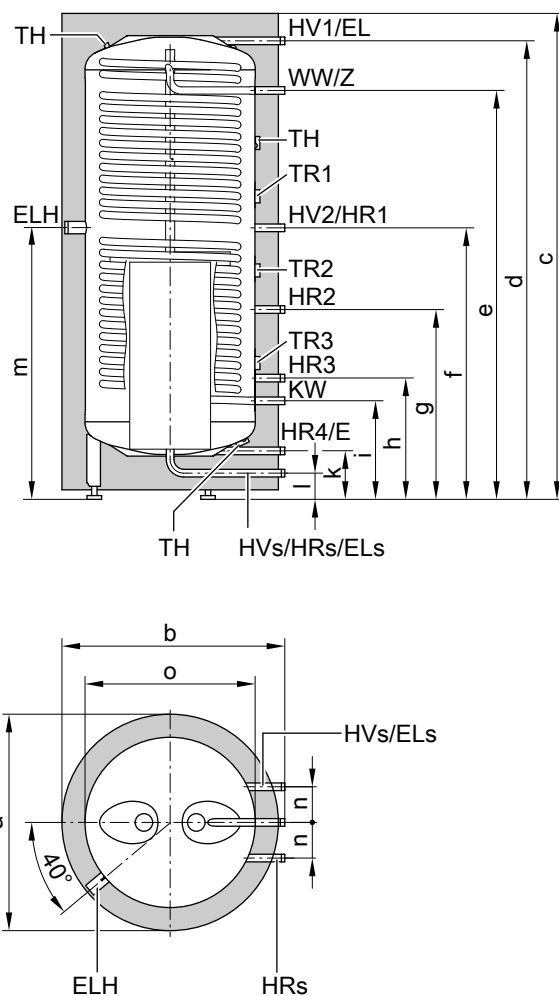

- E Drain outlet
- EL Air vent valve

Specification for types SVKC, SVSB (cont.)

EL _s	Air vent valve for solar indirect coil
ELH	Immersion heater (sleeve Rp 1½)
HR	Heating water return
HR _s	Heating water return for solar thermal system
HV	Heating water flow
HV _s	Heating water flow for solar thermal system
KW	Cold water
TH	Retainer for thermometer sensor or additional sensor (clamping bracket)
TR	Clamping device for securing immersion temperature sensors to the cylinder jacket, with fixing points for 3 immersion temperature sensors per clamping device
WW	DHW
Z	DHW circulation (threaded DHW circulation fitting, accessories)

Dimensions of type SVSB

Cylinder capacity		I	750	950
Length (∅)	a	mm	1064	1064
Width	b	mm	1119	1119
Height	c	mm	1900	2200
	d	mm	1787	2093
	e	mm	1558	1863
	f	mm	1038	1158
	g	mm	850	850
	h	mm	483	483
	i	mm	383	383
	k	mm	145	145
	l	mm	75	75
	m	mm	1009	1135
	n	mm	185	185
Length excl. thermal insulation	o	mm	790	790

Continuous output

Continuous output at heating water flow temperature of 70 °C	kW	15	22	33
For DHW heating from 10 to 45 °C	l/h	368	540	810
– Heating water flow rate (measured via HV ₁ /HR ₁)	l/h	252	378	610
For DHW heating from 10 to 60 °C	l/h	258	378	567
– Heating water flow rate (measured via HV ₁ /HR ₁)	l/h	281	457	836

Information on continuous output

When designing systems with the specified or calculated continuous output, allow for a matching circulation pump. The stated continuous output is only achieved if the heat generator's rated heating output is ≥ the continuous output.

Performance factor N_L to DIN 4708

Cylinder capacity	I	750	950
Performance factor N_L at 70 °C heating water flow temperature			
Subject to the heating output delivered by the boiler Q _D			
15 kW		2.00	3.00
18 kW		2.25	3.20
22 kW		2.50	3.50
27 kW		2.75	4.00
33 kW		3.00	4.60

- The performance factor N_L depends on the cylinder storage temperature T_{cyl}.
- Cylinder storage temperature T_{cyl} = cold water inlet temperature + 50 K ^{+5 K/-0 K}

Standard values for performance factor N_L

- T_{cyl} = 60 °C → 1.0 × N_L
- T_{cyl} = 55 °C → 0.75 × N_L
- T_{cyl} = 50 °C → 0.55 × N_L
- T_{cyl} = 45 °C → 0.3 × N_L

Peak output over 10 min, relative to performance factor N_L

Cylinder capacity	I	750	950
Peak output at 70 °C heating water flow temperature and DHW heating from 10 to 45 °C			
Subject to the heating output delivered by the boiler Q _D			
15 kW	l/10 min	190	230
18 kW	l/10 min	200	236
22 kW	l/10 min	210	246
27 kW	l/10 min	220	262
33 kW	l/10 min	230	280

Specification for types SVKC, SVSB (cont.)

Max. draw-off rate over 10 min, relative to performance factor N_L

Cylinder capacity	l	750	950
Max. draw-off rate at 70 °C heating water flow temperature and DHW heating from 10 to 45 °C, with reheating			
Subject to the heating output delivered by the boiler Q_D			
15 kW	l/min	19.0	23.0
18 kW	l/min	20.0	23.6
22 kW	l/min	21.0	24.6
27 kW	l/min	22.0	26.2
33 kW	l/min	23.0	28.0

Drawable water volume

Draw-off rate with cylinder volume heated to 60 °C	l/min	10	20
Drawable water volume without reheating			
Water at $t = 45$ °C (mixed temperature)			
750 l	l	255	190
950 l	l	331	249

Pressure drop on the DHW side

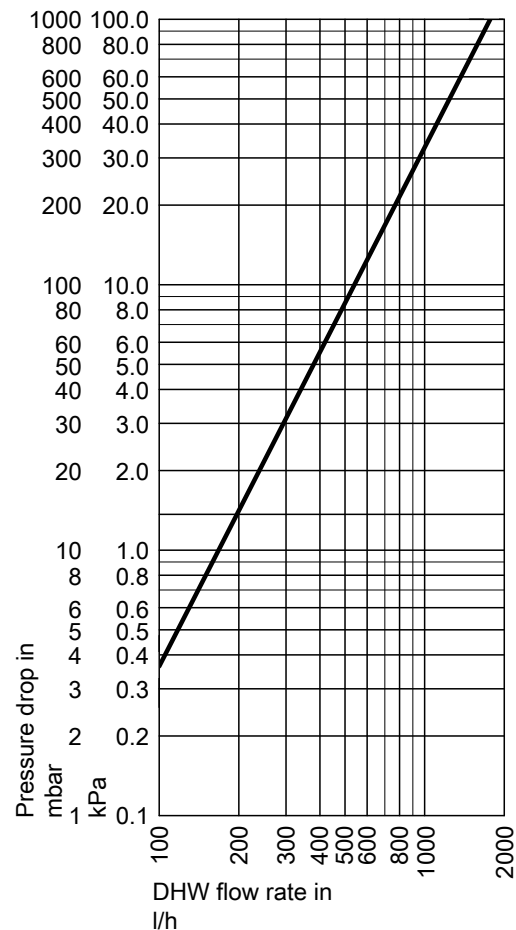

Pressure drop on the heating water side

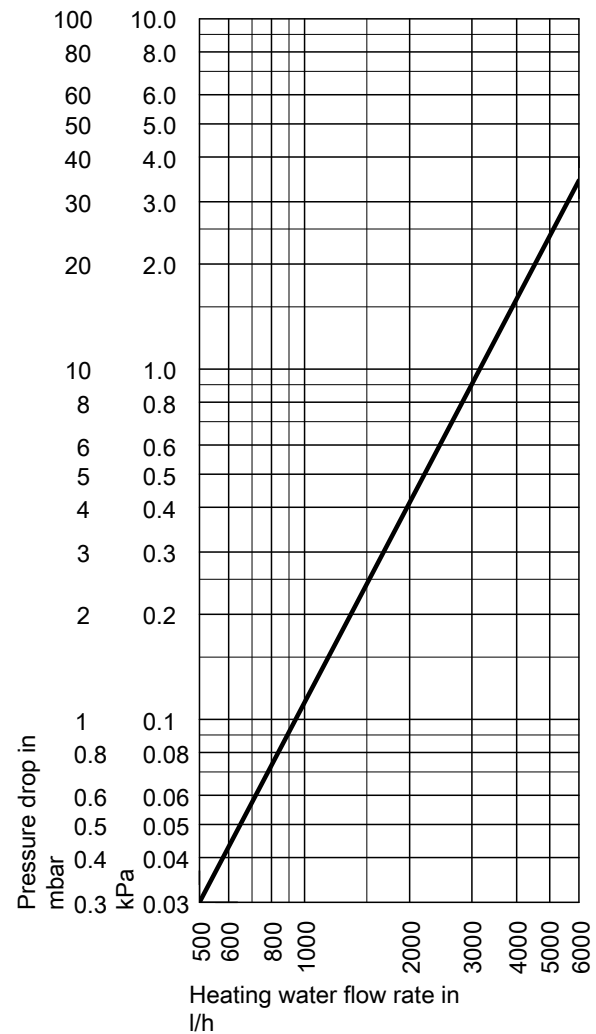

Note

Higher flow rates cause turbulent flow and noise.

Specification for types SVKC, SVSB (cont.)

Pressure drop on the solar side

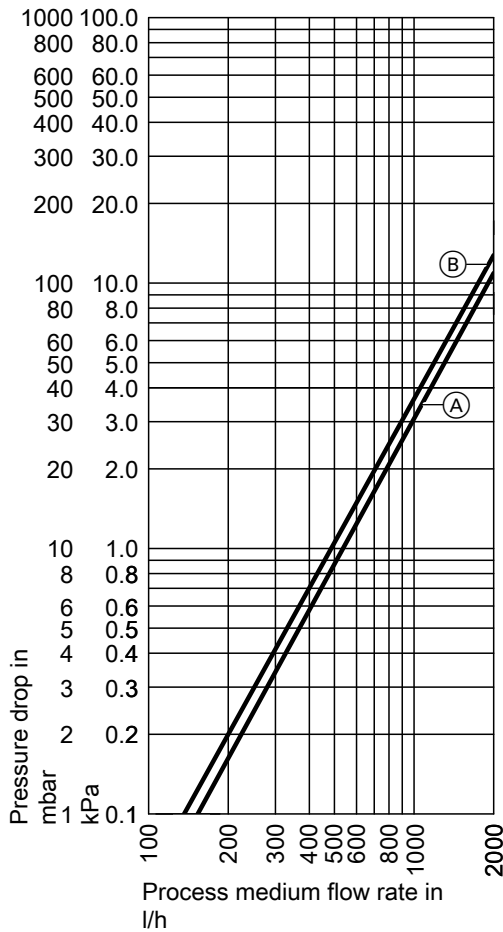

- (A) Cylinder capacity 750 l
(B) Cylinder capacity 950 l

Design information

Heating water flow temperatures in excess of 110 °C

For these operating conditions, DIN 4753 recommends the installation of a type-tested high limit safety cut-out in the DHW cylinder, which limits the temperature to 95 °C.

Warranty

Our warranty for DHW cylinders requires that the water to be heated meets the DHW quality in accordance with current potable water regulations and that existing water treatment systems work properly.

Heat transfer surface

The corrosion-resistant, protected heat transfer surface (DHW/heat transfer medium) complies with EN 1717/DIN 1988-100 version 2.

Immersion heater

When using third party products, the threaded immersion heater must have an unheated length of at least 130 mm.

Design information (cont.)

Intended use

The appliance is only intended to be installed and operated in sealed unvented systems that comply with EN 12828 / DIN 1988, or solar thermal systems that comply with EN 12977, with due attention paid to the associated installation, service and operating instructions. DHW cylinders are only designed to store and heat water of potable water quality. Heating water buffer cylinders are only designed to hold fill water of potable water quality. Only operate solar collectors with the heat transfer medium approved by the manufacturer.

Intended use presupposes that a fixed installation in conjunction with permissible, system-specific components has been carried out.

Commercial or industrial usage for a purpose other than heating the building or DHW shall be deemed inappropriate.

Any usage beyond this must be approved by the manufacturer for the individual case.

Incorrect usage or operation of the appliance (e.g. the appliance being opened by the system user) is prohibited and results in an exclusion of liability.

Incorrect usage also occurs if the components in the system are modified from their intended use (e.g. through direct DHW heating in the collector).

Adhere to statutory regulations, especially concerning the hygiene of potable water.

Accessories

Solar-Divicon with connection set

- **Part no. Z021905**
With SDIO/SM1A electronics module
- **Part no. Z021906**
With Vitosolic 100, type SD1
- **Part no. Z021907**
Without solar control unit

Fully fitted set for connection to the solar side of the solar indirect coil in the heating water buffer cylinder:

- Solar-Divicon, type PS 10 (pump module for collector circuit) for mounting on the cylinder with a variable speed high efficiency circulation pump
- Pre-assembled pipework with fittings for connection to the Vitocell
- Versions with SDIO/SM1A electronics module, with Vitosolic 100, type SD1 or without solar controller

Note

To mount the Solar-Divicon, pipe bends (A) are turned towards the front of the heating water buffer cylinder.

Table of dimensions

Cylinder capacity	l	750	950
a	mm	960	960
b	mm	580	580
c	mm	250	250
d	mm	1250	1250
Weight of Solar-Divicon	kg	7	7

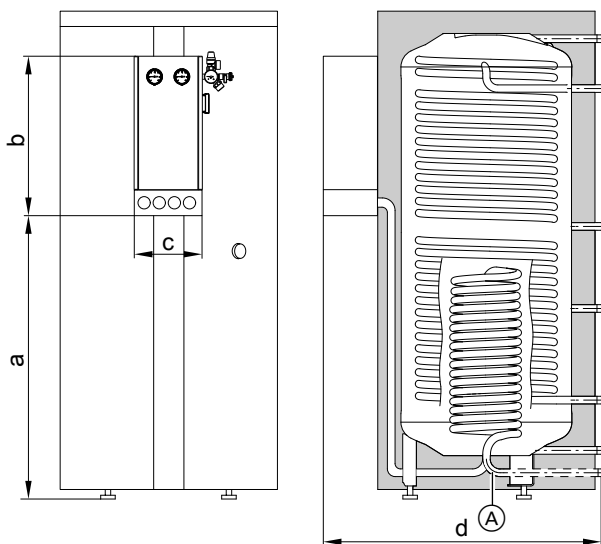

Safety assembly to DIN 1988

- **Part no. 7180662**
10 bar (1 MPa)
- **AT: Part no. 7179666**
6 bar (0.6 MPa)
- DN 20/R 1
- Max. heat input: 150 kW

Accessories (cont.)



Components:

- Shut-off valve
- Non-return valve and test connector
- Pressure gauge connector
- Diaphragm safety valve

Threaded DHW circulation fitting

Part no. 7457484

For connecting a DHW circulation pipe to the DHW connection

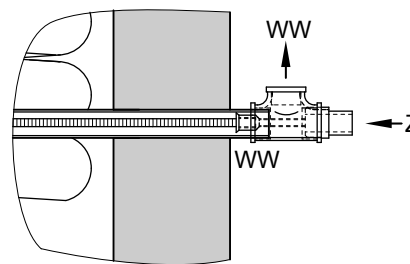

WW DHW
Z DHW circulation

Temperature controller

Part no. 7151989

- With a thermostatic system
- With selector on the outside of the casing
- Without sensor well
- With top-hat rail to be fitted to the DHW cylinder or the wall

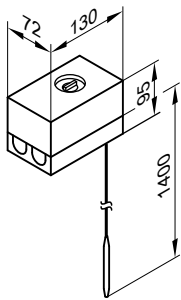

Specification

Connection	3-core lead with a cross-section of 1.5 mm ²
IP rating	IP 41 to EN 60529
Setting range	30 to 60 °C, adjustable up to 110 °C
Switching differential	Max. 11 K
Breaking capacity	6 (1.5) A 250 V~
Switching function	With rising temperature from 2 to 3
DIN registration number	DIN TR 1168

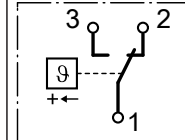

Circulation pump for cylinder heating

Pump type	Part no.
Para 25-180/6-43/SC 9	7172611
Para 30-180/6-43/SC 9	7172612
Stratos 40/1-4	7172613

Pump type		Para 25-180/6-43/SC 9	Para 30-180/6-43/SC 9	Stratos 40/1-4
Energy efficiency index EEI		≤ 0.2	≤ 0.2	≤ 0.2
Voltage	V~	230	230	230
Power consumption	W	3-43	3-43	14-130
Connection	G	1½	2	40
Connecting cable	m	5.0	5.0	5.0
For heat generator		Up to 40 kW	From 40 to 70 kW	From 70 kW

Accessories (cont.)

Dimensions of Para 25-180/6-43/SC 9, Para 30-180/6-43/SC 9

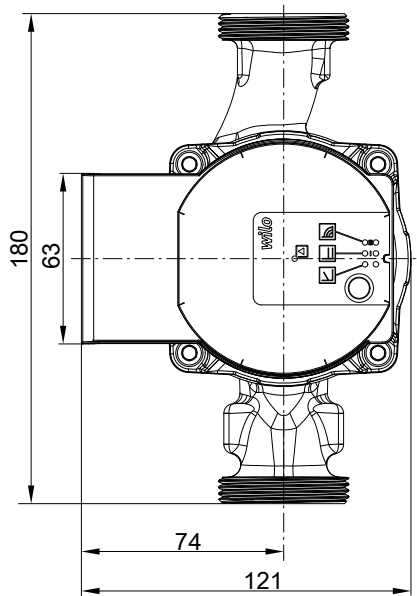

Curves of Para 25-180/6-43/SC 9, Para 30-180/6-43/SC 9

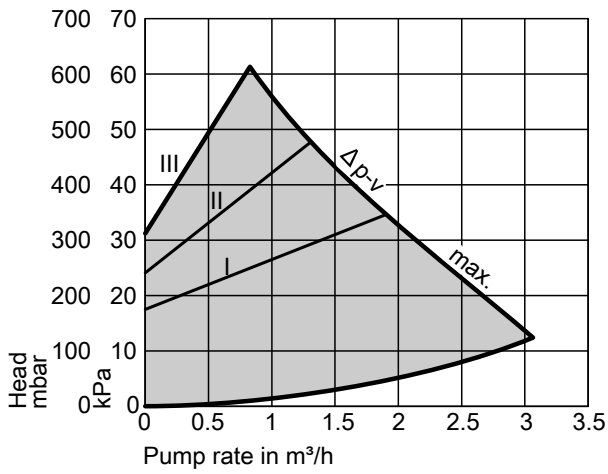

$\Delta p-v$ (variable)

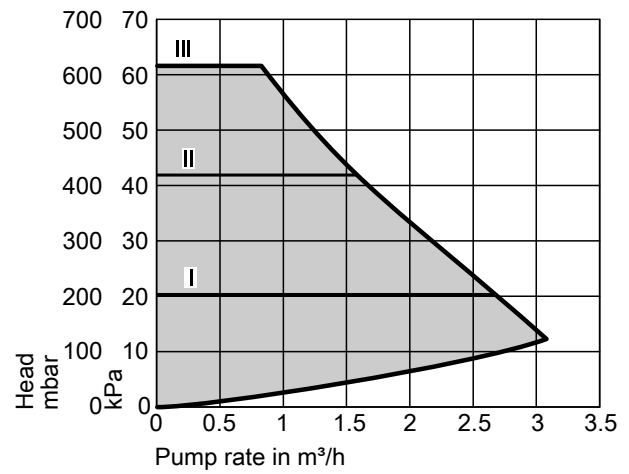

$\Delta p-c$ (constant)

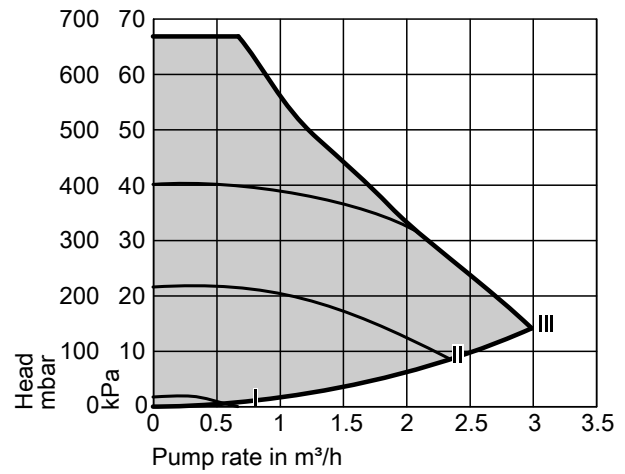

Constant speed

Accessories (cont.)

Dimensions of Stratos 40/1-4

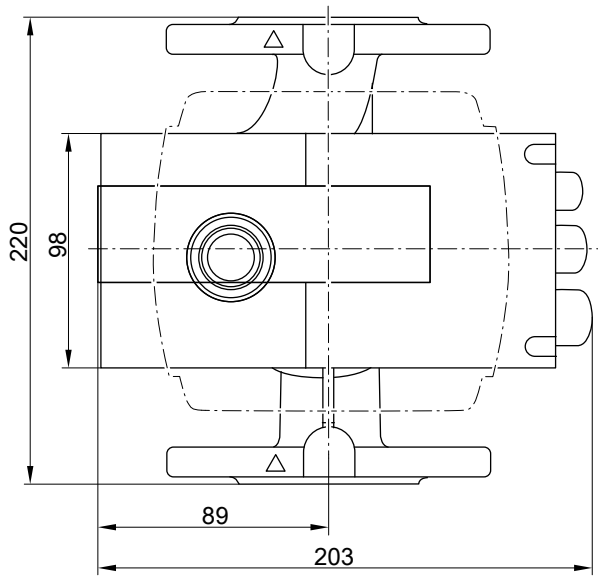

Curves of Stratos 40/1-4

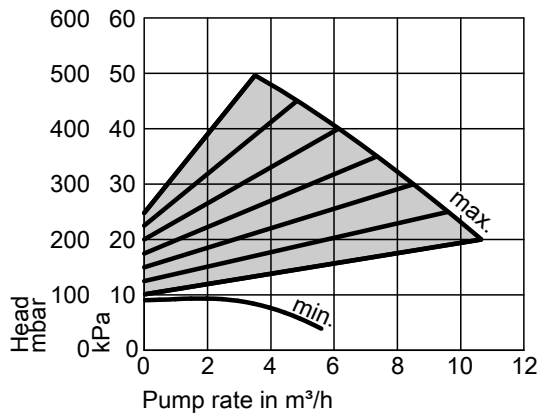

$\Delta p-v$ (variable)

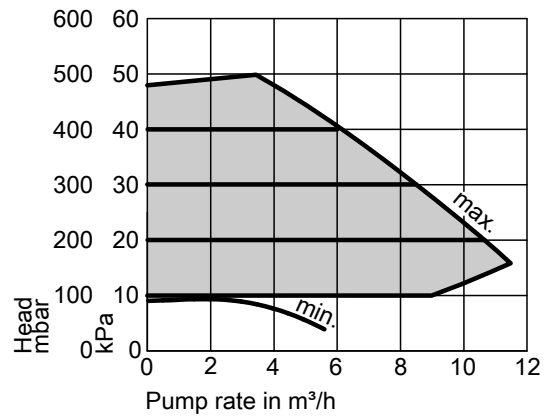

$\Delta p-c$ (constant)

Threaded elbow

Part no. 7219729

For installing a cylinder temperature sensor in the heating flow or heating return

Accessories (cont.)

Thermostatic DHW circulation set

Part no. ZK01284

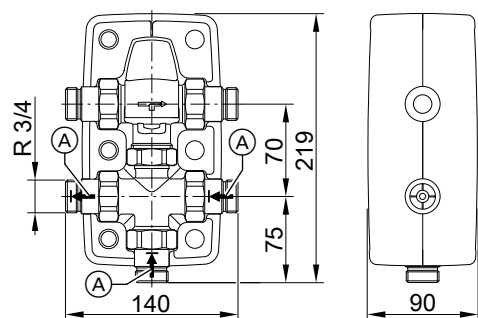

(A) Non-return valve

For limiting the DHW outlet temperature in DHW heating systems with DHW circulation pipe

- Automatic thermostatic mixing valve with bypass line
- Integral non-return valves
- Removable insulation shells

Specification

Connections	R	¾
Weight	kg	1.45
Temperature range	°C	35 to 60
Max. temperature of the medium	°C	95
Operating pressure	bar	10
	MPa	1

Automatic thermostatic mixing valve

Part no. 7438940

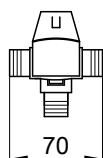

For limiting the DHW outlet temperature in DHW heating systems without DHW circulation pipe

Specification

Connections	G	1
Temperature range	°C	35 to 60
Max. temperature of the medium	°C	95
Operating pressure	bar/MPa	10/1.0

Thermometer, analogue

Part no. 7595765

For installation in the thermal insulation or front panel of the DHW cylinder

Note

Up to 4 thermometers can be fitted to check the temperature profile in the cylinder (e.g. in conjunction with solid fuel boilers). 2 thermometers are included in the standard delivery of the cylinder.

3-way diverter valve (R 1)

Part no. 7814924

For the changeover between central heating and DHW heating when using **one** circulation pump (secondary pump)

- With electric drive
- Connection R 1 (female thread)

Pressure drop graph

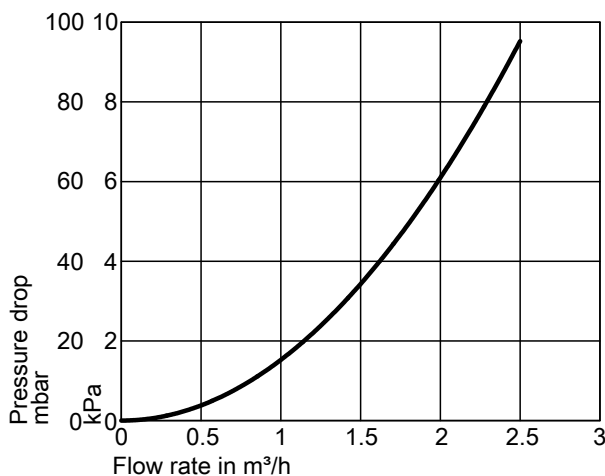

Accessories (cont.)

Immersion heater EHE

- With high limit safety cut-out and temperature controller
- Only for use with soft to medium hard drinking water up to 14 °dH (average hardness level up to 2.5 mol/m³)

Output range	Part no.
– 2/4/6 kW	Z014468
– 4/8/12 kW	Z014469

Specification for immersion heater EHE

Max. output range	kW	6			12		
Rated consumption standard mode/quick heat-up	kW	2	4	6	4	8	12
Rated voltage		1/N/PE 230 V/50 Hz		3/PE 400 V/50 Hz	2/PE 400 V/50 Hz		3/PE 400 V/50 Hz
Rated current	A	8.7	17.4	8.7	10.0	20.0	17.3
Weight	kg	2			3		
IP rating		IP 45					

Specification for immersion heater EHE in conjunction with Vitocell 340-M and Vitocell 360-M

		Vitocell 340-M		Vitocell 360-M	
Cylinder capacity	l	750	950	750	950
Content that can be heated by the immersion heater – EHE at top	l	346	435	346	435
Minimum wall clearance for installation of the immersion heater EHE					
– 2/4/6 kW	mm	650	650	650	650
– 4/8/12 kW	mm	950	950	950	950
Heat-up time from 10 to 60 °C with immersion heater EHE 2/4/6 kW:					
– 2 kW	h	10.0	12.6	10.0	12.6
– 4 kW	h	5.0	6.3	5.0	6.3
– 6 kW	h	3.4	4.3	3.4	4.3
Heat-up time from 10 to 60 °C with immersion heater EHE 4/8/12 kW:					
– 4 kW	h	5.0	6.3	5.0	6.3
– 8 kW	h	2.5	3.2	2.5	3.2
– 12 kW	h	1.7	2.1	1.7	2.1

Transport aid

Part no. ZK01793

For easier handling of vertical DHW cylinders.

- For cylinder capacity 400, 750, 910 and 950 litres
- For DHW cylinders with removable thermal insulation



Subject to technical modifications.

Viessmann Climate Solutions SE
35108 Allendorf / Germany
Telephone: +49 6452 70-0
Fax: +49 6452 70-2780
www.viessmann.com

Viessmann Limited
Hortonwood 30, Telford
Shropshire, TF1 7YP, GB
Telephone: +44 1952 675000
Fax: +44 1952 675040
E-mail: info-uk@viessmann.com