

Article

Valve characteristics for motorized valves in district heating substations

Atli Benonysson and Herman Boysen



Valve characteristics for motorized valves in district heating substations

The present paper describes the results from an investigation carried out in connection with the development of a new valve characteristic for motorized control valves for hot water service in district heating (DH) substations. From a theoretical point of view, the paper discusses basic control theories and physical relationships of crucial importance to this application, including the decisively important relationships between heat exchanger, controller, motor (actuator) and control valve. In addition to the theoretical analysis, the investigation is supported by dynamic simulations and results from laboratory experiments. The result of the investigation was the development of a new valve characteristic as described in this paper.

Nomenclature:

c_p	Heat capacity ((kJ/(kg°C))
$C_{1..C_3}$	Constants
k	Constant
k_{vs}	Maximum capacity of a valve
k_{vk}	Capacity used to characterize linear split-range valve
k_{vo}	Minimum controllable valve capacity
m_1	Primary mass flow (kg/s)
m_2	Secondary mass flow (kg/s)
q	Constant
r	Valve control ratio
s	Valve travel (stroke)
s_{max}	Maximum valve travel
sk, so	Valve travels used to characterise linear split-range valves
sn	Nominal valve travel of a linear valve
Q	Transferred heat (heat load) (kW)
T_{set}	Reference temperature (set point) (°C)
T_{11}	Primary flow temperature (DH supply temperature) (°C)
T_{12}	Primary return temperature (DH return temperature) (°C)
T_{22}	Secondary flow temperature (the controlled temperature) (°C)

T_{21}	Secondary inlet temperature (°C)
U	Heat transfer coefficient (kJ/(m ² °C))
DP_v	Pressure difference across the control valve (bar)
h_{t1}	Primary side temperature efficiency of the heat exchanger

1. Introduction

The trend in hot water service applications in DH consumer substations is to use high-efficiency heat exchangers without storage tanks. A typical example of this system type is shown schematically in Fig.1. One of the main reasons for the more widespread use of this application is the simple and compact equipment required. Another important reason is that this system type enables efficient cooling of the DH water, which is very important in systems based on heat from combined heat and power generation plants. Demands and recommendations issued from DH suppliers and authorities focus increasingly on the performance of the substations, measured by parameters such as the cooling of the DH water and the stability of the temperature control. Especially in hot water service systems, the demands are tough: efficient

cooling, good stability and small variations in water service temperature are demanded even in the case of large and rapid load variations. This in turn imposes increasing requirements on the control system performance, a topic that in recent years has been the subject of several research projects. The economic aspect has to be accounted for too when designing hot water service systems. Thus it has been pointed out that one of the main preconditions for continued and even increased competitiveness of district heating against other energy sources is the development of cost-effective distribution systems.

Since better performance is demanded at the same time as the economic factors are becoming increasingly important, it is vital that all work on development and/or choice of control systems is founded on a thorough understanding of the characteristics of the control problem. Such an understanding is a precondition for the development of control systems that are viable from both a technical and an economic point of view. One of the main components of the control system is the control valve, and here the selection of valve characteristic has both technical and economical implications.

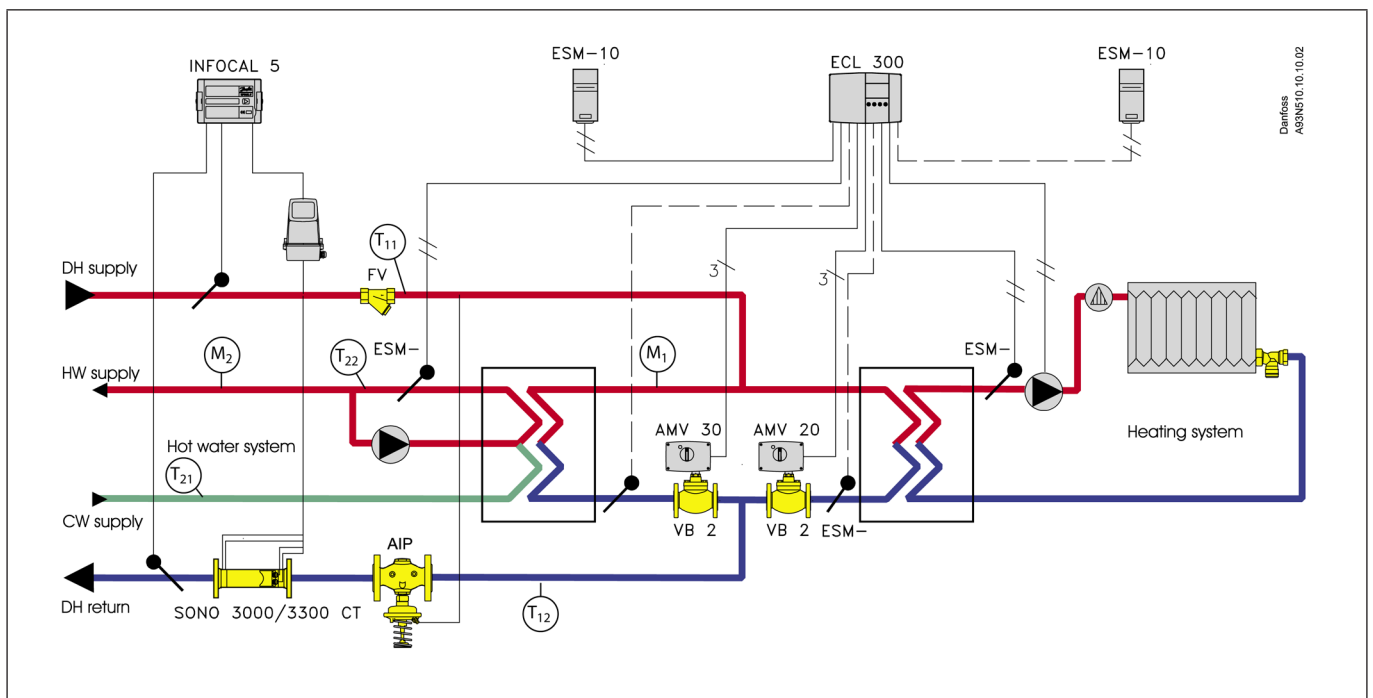

FIGURE 1: District heating consumer substation with a heating and a domestic hot water service system

2. The heat exchanger characteristic and its implications for the control problem

The characteristic of the heat transfer, i.e. the characteristic of the heat exchanger, has great impact on the control problem and thereby on the appropriate choice of components for the control system.

Heat exchangers are frequently referred to as having highly non-linear characteristics because in principle there is a non-linear relationship between the flow on the primary side and the transferred heat. In papers and articles written on the control of heat exchangers it is frequently assumed that a load-linear control loop is desirable in order to obtain stable temperature control.

The term "load-linear control loop" means that there is a linear relationship

between the position of the control valve and the heat transferred, see for example /6/. These two assumptions generally lead to the conclusion that valves with quadratic or exponential characteristic curves ought to be used to counteract the non-linearity of the heat exchanger, thus achieving the desired load linearity, see for example /7/.

Although these assumptions are valid in many cases, they are not appropriate for all applications. Especially in systems where highly efficient heat exchangers

are used and where the flows are variable, the conditions can be quite different. High-efficiency heat exchangers and large variations in flows are very typical for DH substations.

2.1 The static heat exchanger characteristic

As already mentioned, in principle the heat exchanger characteristic is non-linear, meaning that there is a non-linear relationship between the regulated (primary) flow and the heat transferred, see for example /7/.

Just how non-linear the overall characteristic of the heat exchanger is in practice however depends entirely on its capacity and on how much the water flow through the heat exchanger varies. The bigger the capacity of the heat exchanger compared to the nominal heat load of the system, and the more direct the relationship between load level and flow rates, the closer to linear the characteristic becomes.

Disregarding variations in the heat transfer coefficient, the static characteristic for a heat exchanger depends on the temperature efficiency of the primary side, see for example

/1/ or /3/. The temperature efficiency, h_{t1} , specifies the ratio between the maximum temperature difference and the cooling of the DH water, see Eqn. 1:

$$\eta_{t1} = \frac{T_{11} - T_{12}}{T_{11} - T_{21}} \quad (1)$$

Fig. 2a shows the static heat exchanger characteristic under the condition of constant heat transfer coefficient, with constant secondary side temperatures (T_{22} , T_{21}) and constant flow temperature (T_{11}) on the primary side. The primary and secondary flows (m_1 and m_2), along with primary return temperature (T_{12}), thus vary with the load. It can be seen that the form of the static characteristic is highly dependent on h_{t1} . However, the assumption of constant heat transfer coefficient is unrealistic. It is well known that the heat transfer is highly dependent on the flow rate.

In terms of the heat transfer theory this is due to the fact that the Reynolds number forms part of the equation for the Nusselt number (which determines the heat transfer coefficient), and the Reynolds number is directly related to the flow rate /2/. Ignoring the resistance through the walls (the plates) the general relationship between the flow rates and the heat

transfer coefficient can be expressed as /2/:

$$U = \frac{k}{\frac{1}{m_1^q} + \frac{1}{m_2^q}} \quad (2)$$

The exponent q is frequently referred to in literature, and its numerical value can generally be expected to be in the interval 0.6 – 0.7, see for example /5/. Fig. 2b shows the static heat exchanger characteristic under the same conditions as were valid for Fig. 2a, apart from the fact that variations in the heat transfer coefficient due to varying flow rates are now accounted for.

An exponent of $q = 0.63$ is assumed.

The nominal value of h_{t1} in DH hot water service systems is generally in the range 0.5 - 0.7 /1/, depending on the sizing of the system. From Fig. 2b it can be seen that in this range the effective heat exchanger characteristic is very close to being linear. The higher the demands on the cooling of the DH water are, the larger h_{t1} becomes. The static characteristic of an oversized heat exchanger thus will be more linear than that of an undersized one. It must be assumed that the sizing case



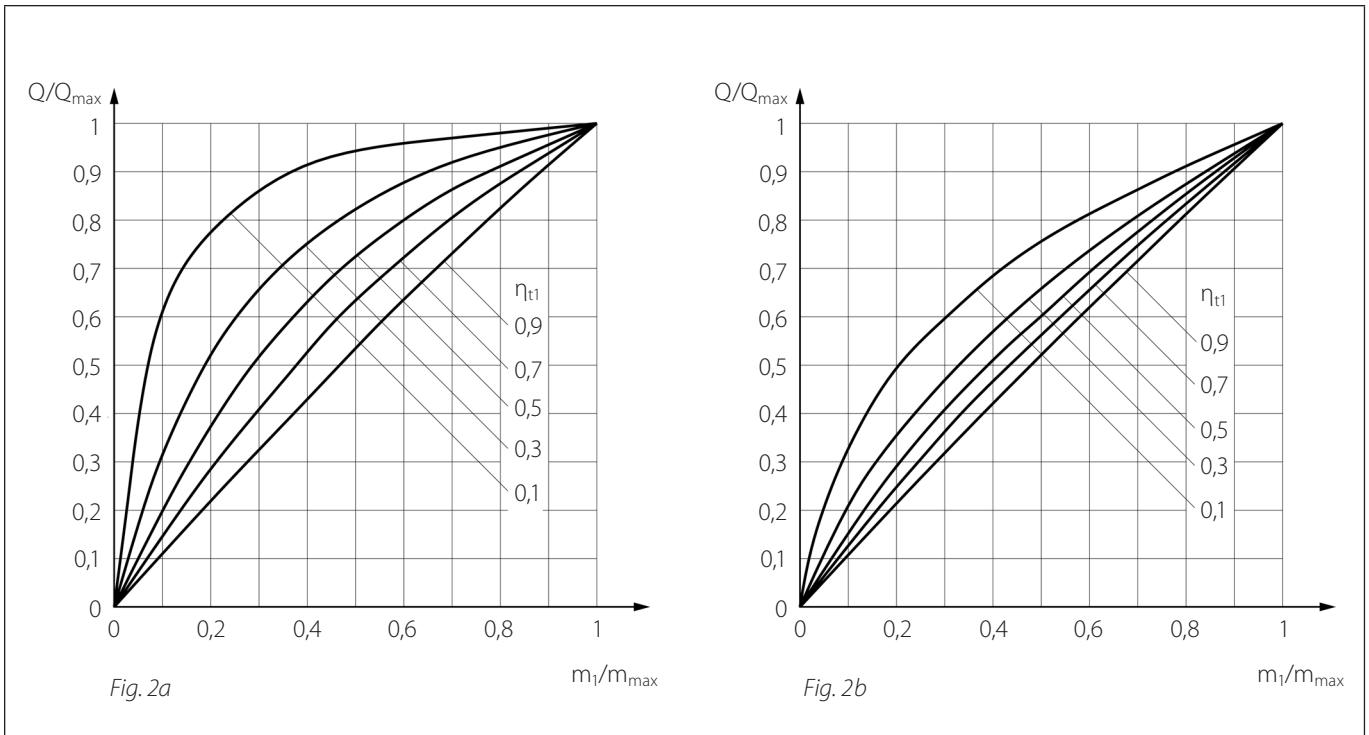

FIGURE 2: Q-m1 relationship with constant $U/5/$ (a); Q-m1 relationship with variable $U/5/$. (b)

represents the highest demand placed on the heat exchanger (highest load at lowest primary flow temperature), and therefore the temperature efficiency will be even higher in other situations. Further, the size of a heat exchanger will always be selected to be on "the safe side", resulting in a further increase of the temperature efficiency. When taking all these considerations into account, a static characteristic for a heat exchanger used in a DH hot water service and heating systems can for all practical purposes assumed to be linear /5/.

This means that the relation between the primary flow and the transferred heat can be taken as linear. In order to achieve linearity between the valve position and the transferred heat, a linear valve characteristic curve is therefore appropriate.

It must be emphasized that this is only valid in systems where the temperature efficiency is high. This degree of linearity of the heat exchanger characteristic will not be seen in, for example, air conditioning systems where the temperature efficiency is lower and the flows are often constant. To obtain load linearity in these kinds of systems, valves with non-linear (e.g. exponential or quadratic) characteristics will be needed.

2.2 Characteristics of the control loop

As already discussed, the fact is that in a normal district heating application there is a close-to-linear relationship between the flow on the primary side and the heat throughput of the heat exchanger.

However, in order to obtain stable temperature control, it is also generally desirable for the loop gain to remain approximately constant despite varying load levels. A load-linear heat exchanger circuit will have constant loop gain if there is a linear relationship between the load and the controlled variable. Normally, the controlled variable is the secondary output temperature (T_{22}), i.e. the controller logs T_{22} and tries to keep it constant despite load variations by adapting the primary flow. As there is a highly non-linear relationship between variations in the heat load and variations in T_{22} , depending on the flow rate on the secondary side (m_2), the loop gain of the system can in fact exhibit large variations although the relationship between primary flow and heat throughput is linear.

This non-linearity can be seen in the following reasoning:

The controller logs T_{22} and attempts to keep it constant. The controller thus will "see" variations in load conditions as variations in T_{22} (T_{22} rises when the load falls and vice versa). When T_{22}

increases, the controller will send a "close" signal to the control valve, and when T_{22} decreases the controller will send an "open" signal. Normally the controller is linear, and therefore a given change in T_{22} will always result in a given magnitude of "open" or "close" signals. Thus the same deviation between T_{22} and the set value (T_{set}) will always lead to the same controller reaction, given that the settings of the controller remain unchanged. However, a given T_{22} deviation is not a direct measure of the magnitude of the change in primary flow needed to bring T_{22} back to the set value.

How large a flow adjustment is needed depends on the effect deviation, which in turn is directly related to the product of the temperature deviation and the flow on the secondary side (i.e. $DQ = m_2 \times cp \times (T_{22} - T_{set})$). Thus the necessary primary flow correction not only depends on the temperature deviation "seen" by the controller, but also on the actual level of the secondary flow (m_2) about which the controller normally has no information. Expressed in a less theoretical way, the missing information on the load level leads the controller to "overreact" at low loads, and to be too slow at high loads.

This can also be demonstrated mathematically.

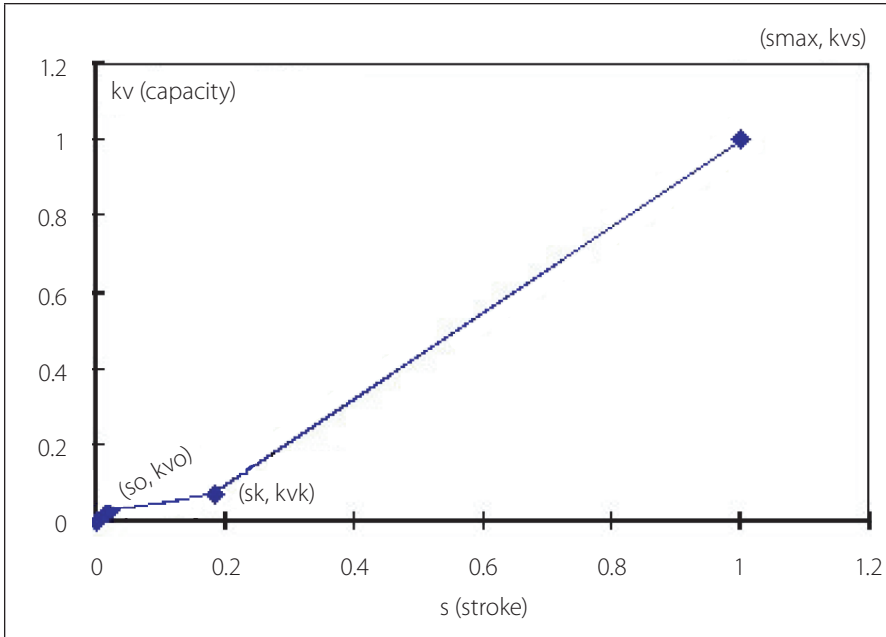

FIGURE 3: The fundamental characteristic of a split characteristic valve

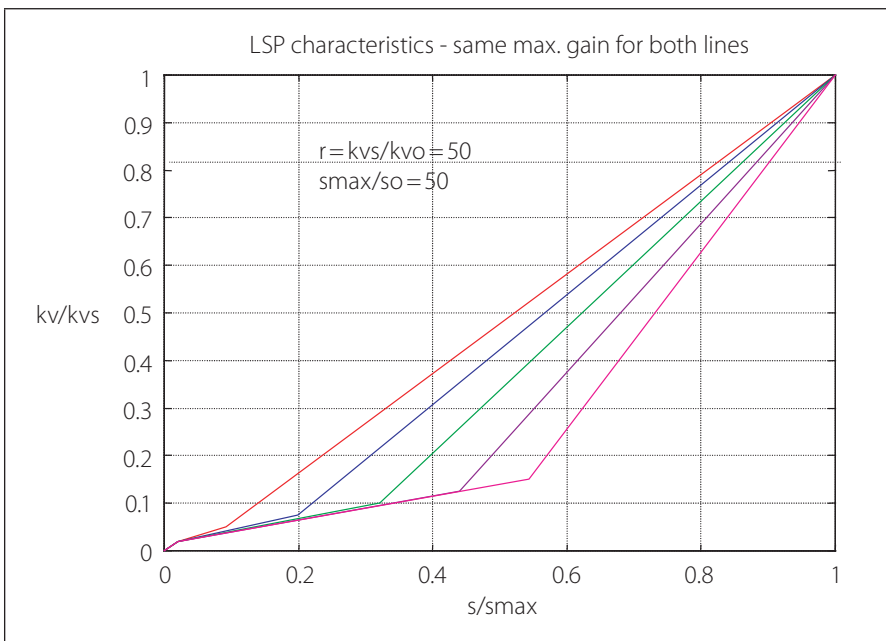

FIGURE 4: Split characteristic with different combinations of sk and kvk

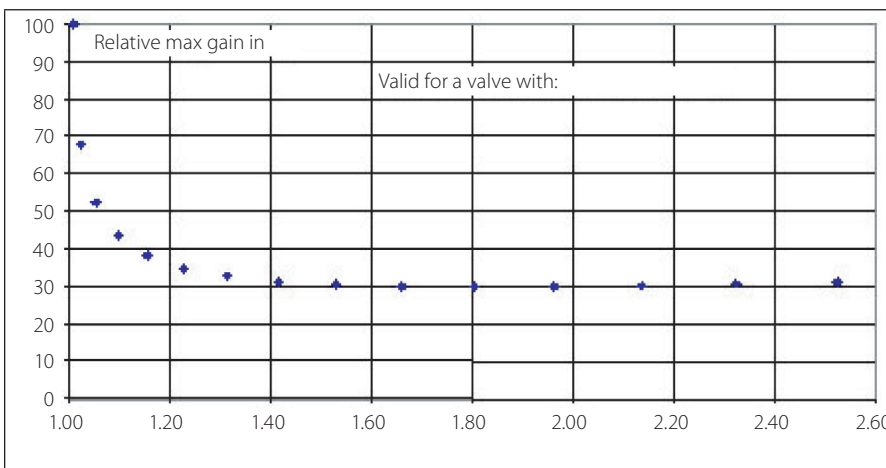

FIGURE 5: An indicative relationship between the largest gain of the control loop and the stroke of a valve with a split characteristic, versus a valve with a linear characteristic

Provided the characteristic of the controller and the actuator is linear, a constant static loop gain is obtained when there is a linear relationship between valve travel (s) and T_{22} (the controlled variable). This constraint can be expressed as:

$$\frac{ds}{dT_{22}} = C_1 \quad (3)$$

Given that the static characteristic is approximately linear, it can be shown that this constraint leads to the following demanded relationship between valve travel and primary flow (for the mathematical details please refer to /1/):

$$\frac{dm_1}{ds} = C_2 \quad (4)$$

$$m_1 = e^{C_2 \cdot (s - C_3)} \quad (5)$$

Eqn. (5) shows that to obtain constant loop gain in a control loop for a heat exchanger with a linear static characteristic, the flow must vary by an exponent of the valve travel, and thus also by the exponent of the output signal from the controller. The constant C_2 is in fact a measure of the contribution from the valve characteristic to the total loop gain of the system.

It will be noted that Eqn. (5) is basically the equation for an exponential valve characteristic. One way of obtaining constant loop gain is thus to use a valve with an exponential characteristic. However, the exponential compensation does not necessarily have to be derived from the valve characteristic, in principle it can be applied anywhere in the control loop, e.g. by the combination of a linear valve and a controller with an exponential characteristic.

It should also be noted that true exponential compensation is demanded only if completely constant loop gain is desired. But this is not necessary in practice, for here it is most important to reduce the variations in loop gain to an extent that allows good regulation under all conditions. This can in fact be achieved without a full-blown exponential compensation. See the following pages for further discussion on the subject.

3. Exponential versus linear characteristics

The following discussion on valve characteristics presupposes conventional linear controllers and linear actuators.

While the exponential valve characteristic is preferable in order to obtain the best conditions for stable temperature regulation, it also has several drawbacks. Thus exponential valves demand fast (and therefore relatively expensive) actuators. This is because the stroke of the valves is, typically, relatively long, and because the long “flat” part of the characteristic demands a relatively long valve movement when compensating for load changes within the lower part of the operating range $/1/$.

Concerning the control ratio, exponential valves normally have a drawback when compared with linear valves, i.e. the control ratio natural for a linear valve is expensive to obtain in exponential valves. An adequate control ratio is essential for stable regulation at low loads.

Linear valves normally have a very high control ratio, and the steep characteristic and short stroke permit fast regulation even with relatively slow (and therefore relatively cheap) actuators. The linear valve, however, has the drawback that the loop gain varies greatly within the operating range.

As the loop gain is largest at small valve openings (small m_1 leads to high C_2 -value in Eqn. (4)), all controller settings must be tuned for stable regulation at the lowest flow rates, resulting in unnecessarily slow regulation at high flow rates.

When using the most commonly applied PI-controllers, good results can nevertheless be obtained with linear valves despite the variable loop gain, since the I-function will prevent permanent offset, even though a relatively wide P-band has to be selected to obtain stable regulation at low flow rates. However this only remains valid for as long as the resolution of the controller and actuator is good enough, as activation in very small steps is needed to ensure stable regulation at the lowest flow rates.

If the actuator activates the valve in steps that are too large, the result is an outlet temperature (T_{22}) that constantly hunts around the set point, even though the P-band is actually wide.

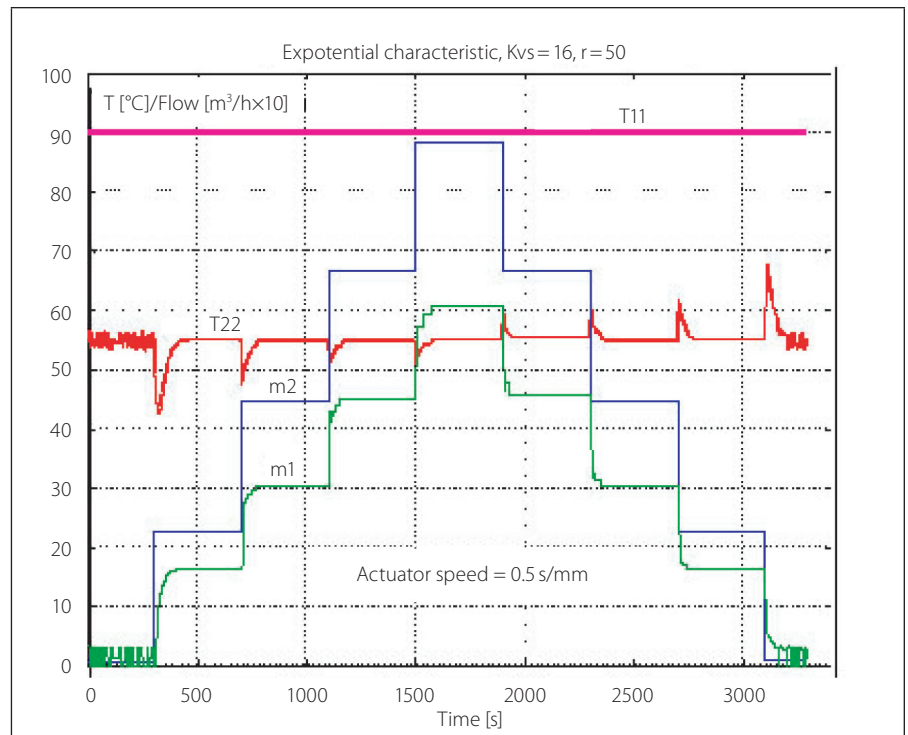

FIGURE 6a: An example on control with exponential characteristic

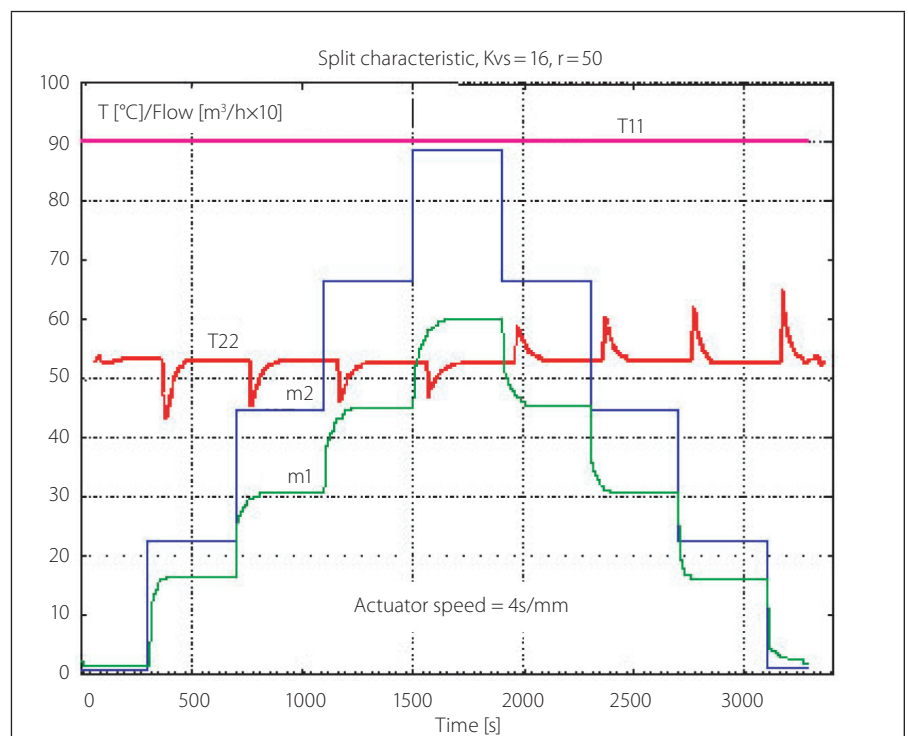

FIGURE 6b: An example on control with split characteristic

In practice, it is the resolution of the controller/actuator combination that puts a constraint on the use of linear valves to control heat exchangers.

Thus both linear and exponential valves have some advantages and drawbacks, the advantages of the linear valve being its cost-effectiveness, its fast regulation and its good regulation ratio, whereas the

advantage of the exponential valve is the constant loop gain which facilitates stable regulation.

To some extent it is possible to combine the advantages of these two different characteristics by means of a piecewise linear characteristic (split-range), and thus to obtain both fast and stable regulation, while still maintaining cost-effectiveness. This

has been done with good results in a new self-acting controller for small hot water service systems by combining a linear valve with a piecewise linear actuator (the Danfoss AVTQ controller, see /1/).

4. The concept of linear split characteristic

The focus here is on a valve characteristic formed by two linear parts, where the slope of the first part is considerably smaller than the slope of the second part of the characteristic - i.e. a linear split-range valve (split characteristic), see Fig. 3.

The purpose of this characteristic is to combine the advantages of both linear and exponential valve characteristics, while maintaining the cost-effectiveness of a linear valve solution.

The incorporation of all the advantages of a normal linear valve in a split characteristic valve requires a double valve cone, i.e. the double valve cone is necessary to obtain the control ratio normal for a linear valve.

This paper, however, concentrates on a valve concept using only one valve cone. In this concept, the problem with the control ratio is similar to that which is the case for exponential valves.

Thus, a valve with linear split-range characteristic and only one valve cone offers the fast regulation and short stroke in advantage of an exponential valve, with the potential of being combined with a much slower (and cheaper) actuator than would be the case with an exponential valve.

Compared to a linear valve, the loop gain at the lowest flow rates is reduced because of the smaller slope of the first part of the characteristic. This improves the stability of the control system.

The problem now is to find the most optimum intersection and slopes of the two lines forming the valve characteristic.

The characteristic is defined by three points: (smax,kvs), (sk,kvk) and (so,kvo) - see Fig. 3. smax and kvs are defined by the max. stroke and the capacity of the valve, whereas kvo is defined by the control ratio:

$$kvo = \frac{kvs}{r} \quad (6)$$

so and kvo depend on the actual valve design and tolerances.

As can be seen from Eqn. (4), an approximately constant loop gain is obtained if the ratio between the slope of the valve characteristic and the actual kv-value remains unchanged throughout the operating range (as is the case with the exponential valve).

This however cannot be obtained with a split characteristic. Here the gain varies with the degree of opening, the largest gains being encountered at the lowest sections of each of the two lines forming the characteristic. Thus the largest gain on the first "flat" line will occur at kvo, while the largest gain on the second "steep" line will occur at kvk (refer to Eqn. (4)). The smaller the slope of the first line, the lower the gain at kvo becomes, and the better stability is obtained. Similarly, the longer the first "flat" line (up to a certain limit), the larger is the opening degree at kvk, and the lower the gain at kvk becomes. If we focus solely on stability, the first "flat" piece of line should therefore be relatively long. The speed of regulation however also has to be considered. To obtain the fastest control it is important not to make the first "flat" line of the characteristic much longer than is necessary to obtain stable control.

In order to accommodate the demand for both fast and stable control, it is therefore appropriate to construct the characteristic in such a way that the largest gains on both pieces of lines (i.e. at kvo and kvk respectively) are approximately equal.

This ensures that when the slope of the first "flat" line has been determined for a stable control at kvo, the length of this piece of line does not become longer than necessary to ensure the same degree of stability at kvk. This constraint can be expressed in the following way (please note the relation to Eqn. (4)):

$$\frac{kvk - kvo}{sk - so} = \frac{kvs - kvk}{smax - sk} \quad (7)$$

It can be shown that the above constraint results in the following relationship between sk and kvk:

$$A = kvk \left(kvk - \frac{kvs}{r} \right) \quad (8)$$

$$B = kvs \left(\frac{kvs}{r} - \frac{kvk}{r} \right) \quad (9)$$

$$sk = \frac{smax \cdot A + so \cdot B}{A + B} \quad (10)$$

$$kvk \geq \frac{kvs}{r} \quad (11)$$

In Fig. 4 the fundamental valve characteristics of a few combinations of sk and kvk are plotted for a valve with control ratio r = 50. The higher the kvk/kvs ratio, the longer becomes the first "flat" line and the stroke of the valve.

Compared to a normal linear valve of given capacity (kvs), a split characteristic valve with the same capacity will have a somewhat longer stroke. Denoting the stroke of the linear valve as sn and the stroke of the split characteristic valve as smax, the relationship between smax and sn can be estimated as follows:

$$smax = sn \frac{kvs - kvk}{kvs} + sk \quad (12)$$

A graph indicating the relationship between smax/sn and the gain of a split characteristic valve compared to a normal linear valve can be seen in Fig. 5. It can be seen that by increasing the stroke of the valve by 25% and giving the valve a split characteristic instead of a normal linear characteristic, the largest gain occurring within the operating range can be reduced by approx. 65%. It can also be seen that an increase in stroke of more than approx. 50% has no effect at all.

5. Simulation of heat exchangers control using different valve characteristics

In order to analyze the control of hot water service heat exchangers with different combinations of valve characteristics and actuator speeds, a series of dynamic simulations has been carried out. The simulated system is similar to the one presented in Fig. 1. The conditions for the simulations were as follows:

Nominal temperature sets (for sizing the heat exchanger and control valve):

Temperature primary side:

$$T_{11}/T_{12} = 65/25 \text{ } ^\circ\text{C}$$

Temperature secondary side:

$$T_{21}/T_{22} = 5/55 \text{ } ^\circ\text{C}$$

Differential pressure across the valve:

$DP_v = 1.0 \text{ bar}$ (held constant with a differential pressure controller)

Capacities of the simulated systems:

System 1: $kvs = 16.0$,

max. tapping = 8800 l/h ("Large")

System 2: $kvs = 1.0$,

max. tapping = 504 l/h ("Small")

Tapping program:

The tapping program recommended by the Finnish District Heating Association /4/ was used. The tapping flow (m_2) was thus varied stepwise in accordance with the following sequence, expressed as a percentage of the nominal (max.) tapping flow:

0%-25%-50%-75%-100%-75%-50%-25%-0%.

Circulation flow was held constant at 10% of max. tapping flow, return temperature of circulation flow constant at 50°C.

The set value of T22 (T_{set}) was 55°C.

Controller and sensor:

Sensor time constant = 1.5s (A short sensor time constant is vital for hot water systems). Control algorithms in compliance with the existing Danfoss controllers, type ECL/EPU (PI controllers).

Supply temperature variations:

Lowest supply temp. (summer): $T_{11} = 65^\circ\text{C}$ Highest supply temp. (winter): $T_{11} = 120^\circ\text{C}$

When evaluating the limits for stable regulation, the tapping flow was kept constant at 10% of max. flow.

In compliance with the Finnish specifications /4/, the control is not required to be stable at loads lower than 10%.

The results are summarized below. The findings as presented here are based on dynamic simulations, but it should be emphasized that the results have been verified by a series of laboratory tests. The results of the laboratory tests have in general been in good agreement with the simulated results.

Exponential valve characteristics:

The simulations of the "large" system including a valve with a 20mm stroke indicate that to keep the temporary deviations of T22 from the set value within acceptable limits during load changes an actuator speed of 0.5 - 1 s/mm is required. In the simulations these actuator speeds

resulted in temporary deviations of 12-13°C respectively (worst case). Simulations of the "small" system gave similar results - however a slightly slower actuator is acceptable as a valve stroke of only 16 mm was assumed for this capacity. An example on the simulated results is found in Fig. 6a.

Linear split-range valve characteristic: The simulations revealed that the position of the intersection point between the two lines of the characteristic is fairly important. In order to minimize deviations in T22 from the set value it thus proved to be important not to select a larger k_{vk}/k_{vs} ratio than absolutely necessary, the optimum ratio being somewhat dependent on the size of the valve (larger ratio for smaller valves). With the correct k_{vk}/k_{vs} ratio it proved possible to obtain results that were good both from the point of view of stability and from the point of view of regulation speed (i.e. temperature deviations during load changes).

For both the "large" and the "small" system the combination of a split characteristic valve and an actuator with a speed of only 4-5 s/mm resulted in a performance comparable to the above results (obtained with an exponential characteristic and a fast actuator). The equivalent stroke of the valves, based on a normal stroke of linear valves with similar capacity, was $s_n = 10 \text{ mm}$ in the "large" system and $s_n = 2.6 \text{ mm}$ in the "small" system. An example on the simulated results is found in Fig. 6b.

Thus, when applying a split characteristic it is possible to use actuators which have both a much shorter stroke and a speed which is as low as 20%-25% of that required for an exponential valve. Indeed it is not desirable to use a much faster actuator for the split characteristic valves because limited resolution of "real-world" actuators and controllers can impair stability.

6. Conclusion

This paper has discussed several theoretical relationships of interest as regards the control of heat exchangers in DH substations.

The control of hot water service heat exchangers is especially demanding because good stability and limited variations in water temperature are required even where load variations are large and rapid. The interaction of the components making up the control

system needs special attention if satisfactory results are to be obtained. Not least the combination of valve and actuator must be chosen carefully.

Because of their high temperature efficiency and varying flows, the characteristics of heat exchangers in DH substations can, in general, be expected to be almost linear. However, the problem of varying control loop gain also needs consideration when determining the appropriate valve characteristic.

Simulations as well as subsequent laboratory tests have proved that rather fast actuators are needed for traditional control systems with exponential valves in order to ensure regulation that is fast enough. On the other hand, the stability of the temperature control is generally good when using exponential valves - provided the control ratio is adequate.

The concept of linear split-range (split characteristic) valves is promising as it offers some of the benefits of both linear and exponential valves. It has thus been proved that in hot water service applications the combination of a split characteristic valve and a relatively slow actuator will give a performance fully comparable with that of an exponential valve and a much faster actuator.

Furthermore, the split characteristic solution is more cost-effective, in that the cost of both valve and actuator is considerably lower than is the case with a traditional system incorporating an exponential valve.

Based on these results, Danfoss has now developed an entirely new range of control valves with linear split-range characteristic which, hopefully, will contribute to both better and more cost-effective DH substations in the future.

References

- [1] Benonysson, A., Boysen, H.: *Optimum Control of Heat Exchangers*. 5th International Symposium on Automation of District Heating Systems, Finland, August 1995.
- [2] Benonysson, A.: *Dynamic Modelling and Operational Optimization of District Heating Systems*. Dissertation, Laboratory of Heating and Air Conditioning, Technical University of Denmark, 1991.
- [3] Børresen, B.A.: *Temperaturvirkningsgrad for batterier er afgjørende for god regulering (The temperature efficiency of heat exchangers is decisive for good control)*. Norsk VVS, 12/94.
- [4] Finnish District Heating Association: *District Heating in Buildings Requirements and instructions K1/1992*
- [5] Fridriksson, J.S.: *Test rig for consumer substations in district heating systems*. Master thesis, University of Iceland, Faculty of Engineering, 1996.
- [6] Grindal, A.: *Ventilkarakteristikker - er det på tide at vi gjør noe med dem? (Valve characteristics - is it time to do something about them?)* Norsk VVS, 16/95.
- [7] Hjorthol, E.: *Optimization of Design Values in District Heating Substations by System Simulation*. Dissertation, Institutt for Varme- Ventilasjons- og Sanitærteknikk, Trondheim. VVS-rapport 1990:1.

More articles

- [1] *Optimum control of heat exchangers*, by Atli Benonysson and Herman Boysen
- [2] *Auto tuning and motor protection as part of the pre-setting procedure in a heating system*, by Herman Boysen
- [3] *Differential pressure controllers as a tool for optimization of heating systems*, by Herman Boysen
- [4] *District heating house substations and selection of regulating valves*, by Herman Boysen
- [5] *kv: What, Why, How, Whence?*, By Herman Boysen
- [6] *Pilot controlled valve without auxiliary energy for heating and cooling systems*, by Martin Hochmuth
- [7] *Pressure oscillation in district heating installation*, by Bjarne Stræde
- [8] *Dynamic simulation of DH House Stations*, by Jan Eric Thorsen

More information

Find more information on Danfoss District Energy products and applications on our homepage: www.heating.danfoss.com

Danfoss A/S

DK-6430 Nordborg
Denmark
Tel.: +45 74 88 22 22
Telefax: +45 74 49 09 49
E-mail: danfoss@danfoss.com

Danfoss can accept no responsibility for possible errors in catalogues, brochures and other printed material. Danfoss reserves the right to alter its products without notice. This also applies to products already on order provided that such alterations can be made without consequential changes being necessary in specifications already agreed. All trademarks in this material are property of the respective companies. Danfoss and the Danfoss logotype are trademarks of Danfoss A/S. All rights reserved.